

REVISIONS					
REV	ECO	DESCRIPTION	DATE	BY	APPR
A1	-	RELEASE NEW DRAWING	15JUN18	SULLEN	TOMMY

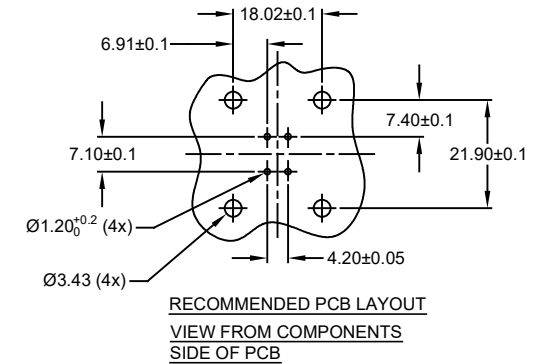
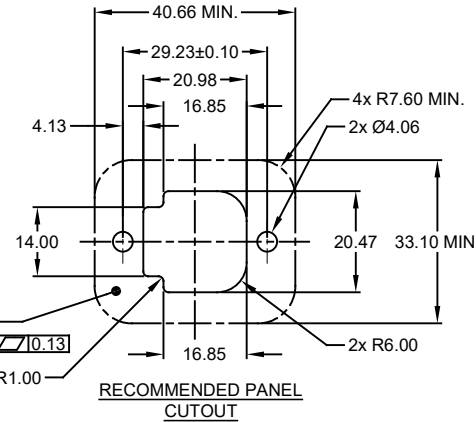
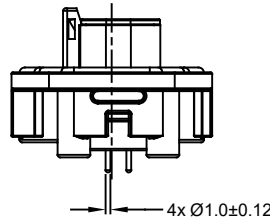
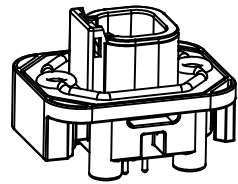
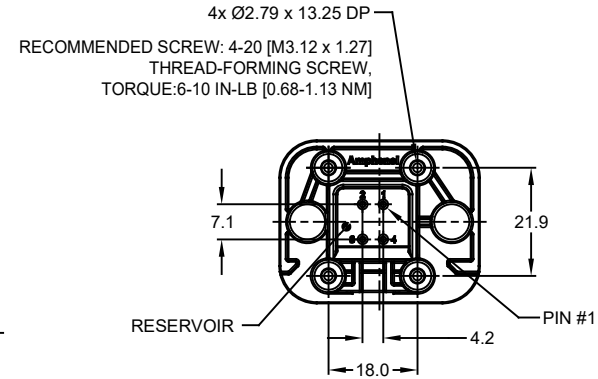
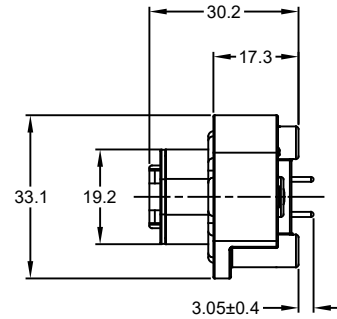
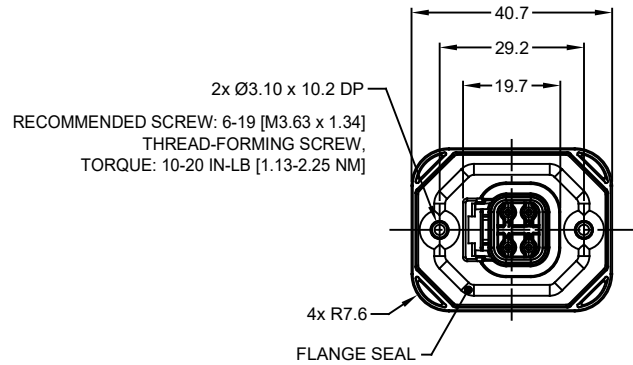

NOTES: UNLESS OTHERWISE SPECIFIED

- MATERIAL:
HOUSING: THERMOPLASTIC, GREY
SEAL: SILICONE RUBBER
CONTACT: COPPER ALLOY
- MODIFICATIONS: FLANGE; STRAIGHT PCB MOUNT
- SPECIFICATIONS:
 - CURRENT RATING: 7.5 AMPS
 - OPERATING TEMPERATURE: -55°C TO +125°C
 - DIELECTRIC WITHSTANDING VOLTAGE: LESS THAN 2 MILLIAMPS CURRENT LEAKAGE @ 1500 VOLTS AC
 - INSULATION RESISTANCE: 1000 MEGOHMS MIN @ 25°C
 - MOISTURE RESISTANCE: IP67 (MATED CONDITION)
 - MATING CYCLE DURABILITY: 100 CYCLES
 - RoHS COMPLIANT
- MATING PART: ATM06-4S*
(* = ALL MODIFICATIONS)
- ALL DIMENSIONS ARE FOR REFERENCE USE ONLY

INTERNAL SEALING SURFACE
FINISH TO BE 3.2/ OR BETTER $\sqrt{0.13}$

ATM15-4P-BMXX VARIANTS		
CONTACT PLATING	POTTING OR NOT IN RESERVOIR	PART NUMBER
GOLD	NO POTTING	ATM15-4P-BM01
GOLD	POTTING	ATM15-4P-BM02
TIN	NO POTTING	ATM15-4P-BM03
TIN	POTTING	ATM15-4P-BM04

ATM15-4P-BMXX		DESCRIPTION		ITEM
QUANTITY	PART NUMBER	MATERIALS LIST		
UNLESS OTHERWISE SPECIFIED				
1) All dimensions are in metric(mm).		SIGNATURES		DATE
2) Tolerances are as follows:		DRAWN: SULLEN ZHANG		15JUN18
1 PL DEC ±0.30		CHECKED: ORION LI		15JUN18
2 PL DEC ±0.15		FRACTIONS ±1/64		
3 PL DEC ±0.08		ANGLES ±1°		
3) Note reference = \triangle		ENGINEER:		
MATERIAL SPECIFICATIONS:		APPROVAL: TOMMY XIE		15JUN18
CUSTOMER:		THIS DRAWING IS SUPPLIED FOR INFORMATION ONLY. DESIGN FEATURES, SPECIFICATIONS AND PERFORMANCE DATA SHOWN HEREON ARE THE PROPERTY OF THE AMPHENOL CORPORATION. NO RIGHTS OF REPRODUCTION ARE IMPLIED. ALL DIMENSIONS ARE SUBJECT TO NORMAL MANUFACTURING VARIATIONS.		
PROCESS SPECIFICATIONS:		SIZE	TYPE	DWG NO.
NEXT ASSY:		B	C-	ATM15-4P-BMXX
		SCALE	NONE	REVISION
				A1
		SHEET 1 OF 1		

TITLE: PCB MOUNT RECEPTACLE 4PIN STRAIGHT FLANGE ATM SERIES
DWG NO: ATM15-4P-BMXX
REV: A1
SHEET 1 OF 1

Amphenol

Sine Systems - www.amphenol-sine.com
44724 Morley Drive
Clinton Township, MI 48036

PCB MOUNT RECEPTACLE 4PIN,
STRAIGHT FLANGE, ATM SERIES