

## ATIR0711S

Photointerrupter - Reflective Type

### FEATURES

- Compact and thin
- Visible light cut-off type
- High sensitivity
- Package: 1000 pcs / Reel
- Moisture sensitivity level: 4
- RoHS compliant

### APPLICATIONS

- Cassette tape recorders, VCRs
- Floppy disk drives
- Various microcomputerized control equipment

### PACKAGE DIMENSIONS

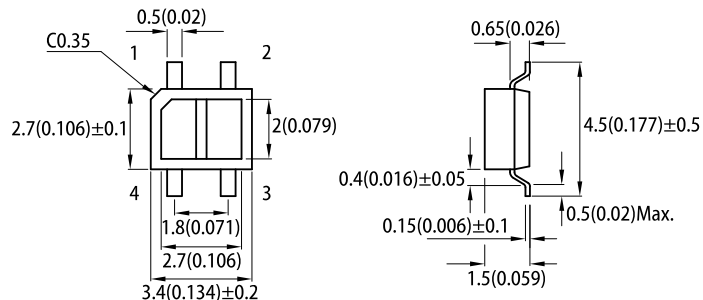

- 1 Anode      2 Emitter  
3 Collector    4 Cathode

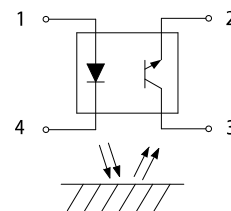

### RECOMMENDED SOLDERING PATTERN

(units : mm; tolerance : ± 0.1)

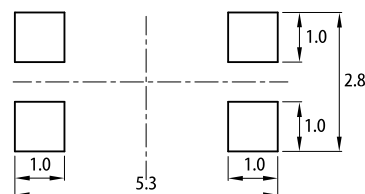

#### Notes:

1. All dimensions are in millimeters (inches).
2. Tolerance is  $\pm 0.25(0.01")$  unless otherwise noted.
3. The specifications, characteristics and technical data described in the datasheet are subject to change without prior notice.
4. The device has a single mounting surface. The device must be mounted according to the specifications.

### ELECTRICAL / OPTICAL CHARACTERISTICS at $T_A=25^\circ\text{C}$

Parameter	Symbol	Value				Units	Test Conditions	
		Code.	Min.	Typ.	Max.			
Input	Forward voltage	$V_F$		1.0	1.2	1.5	V	$I_F=20\text{mA}$
	Reverse current	$I_R$		-	-	10	$\mu\text{A}$	$V_R=6\text{V}$
Output	Collector dark current	$I_{CEO}$		-	$10^{-9}$	$10^{-7}$	A	$V_{CE}=20\text{V}$
Transfer characteristics	Collector Current <sup>[1]</sup>	$I_C$	E	10	-	120	$\mu\text{A}$	$I_F=4\text{mA}, V_{CE}=2\text{V}$
			F	100	-	250		
			G	200	-	400		
	Leak Current <sup>[2]</sup>	$I_{LEAK}$		-	-	0.1	$\mu\text{A}$	$I_F=4\text{mA}, V_{CE}=2\text{V}$
Response time	Rise time	$t_r$		-	20	100	$\mu\text{s}$	$V_{CE}=2\text{V}, I_C=100\mu\text{A}$ $R_L=1\text{K}\Omega, d=1\text{mm}$
	Fall time	$t_f$		-	20	100		

#### Notes:

1. Test condition of collector current is shown below.
2. Without reflective object.
3. Excess driving current and/or operating temperature higher than recommended conditions may result in severe light degradation or premature failure.

#### Test Condition and Arrangement for Collector Current

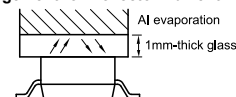

### ABSOLUTE MAXIMUM RATINGS at $T_A=25^\circ\text{C}$

	Parameter	Symbol	Rating	Unit
Input	Forward current	$I_F$	50	mA
	Reverse voltage	$V_R$	6	V
	Power dissipation	$P_D$	75	mW
	Peak Forward Current (Pulse Width $\leq 100\mu\text{s}$ , Duty Cycle=1%)	$I_{FP}$	1	A
Output	Collector-emitter voltage	$V_{CEO}$	35	V
	Emitter-collector voltage	$V_{ECO}$	6	V
	Collector current	$I_C$	20	mA
	Collector power dissipation	$P_C$	75	mW
Operating temperature		$T_{opr}$	-25~+85	$^\circ\text{C}$
Storage temperature		$T_{stg}$	-40~+100	$^\circ\text{C}$

Note:  
1. Relative humidity levels maintained between 40% and 60% in production area are recommended to avoid the build-up of static electricity – Ref JEDEC/JESD625-A and JEDEC/J-STD-033.

### TECHNICAL DATA

Fig. 1 Forward Current vs. Forward Voltage

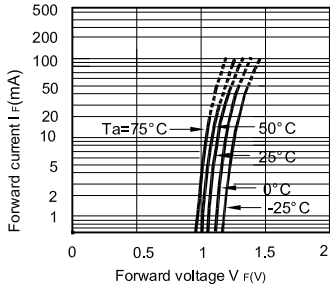

Fig. 2 Collector Current vs. Forward Current

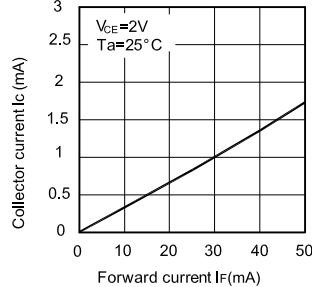

Fig. 3 Collector Current vs. Collector-Emitter Voltage

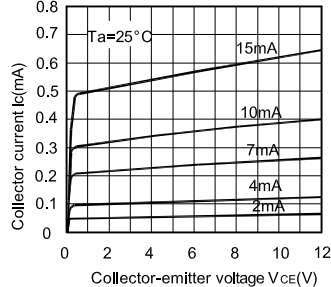

Fig. 4 Relative Collector Current vs. Ambient Temperature

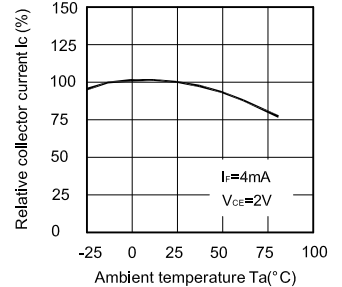

Fig. 5 Response Time vs. Load Resistance

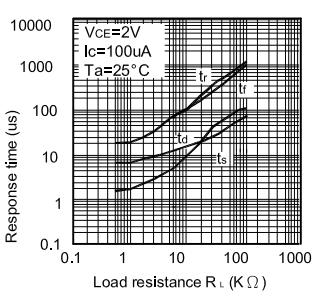

Fig. 6 Collector Dark Current vs. Ambient Temperature

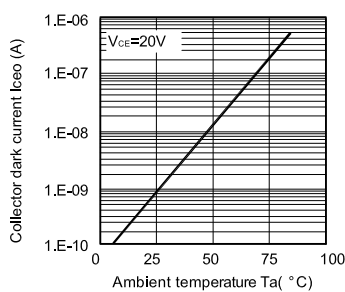

Fig. 7 Relative Collector Current vs. Distance Between Sensor and Al Evaporation Glass

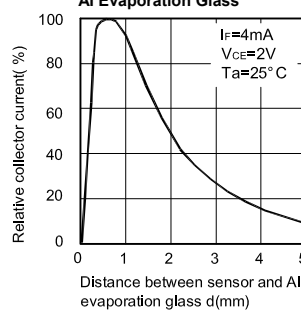
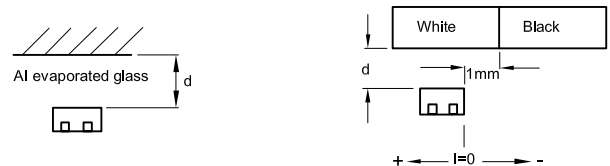
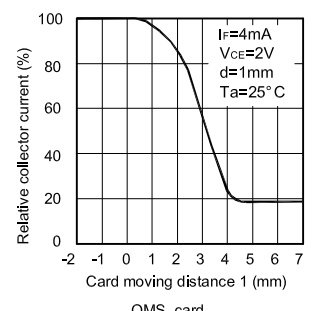
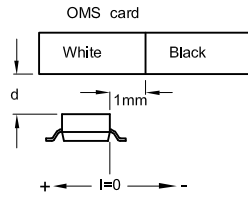
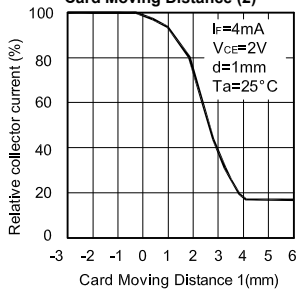

Fig. 8 Relative Collector Current vs. Card Moving Distance (1)



**Fig. 9 Relative Collector Current vs. Card Moving Distance (2)**



**Test Circuit for Response Time**

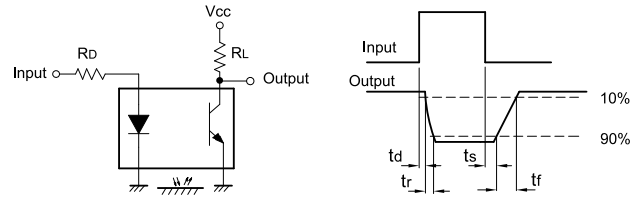

### REFLOW SOLDERING PROFILE for LEAD-FREE SMD PROCESS

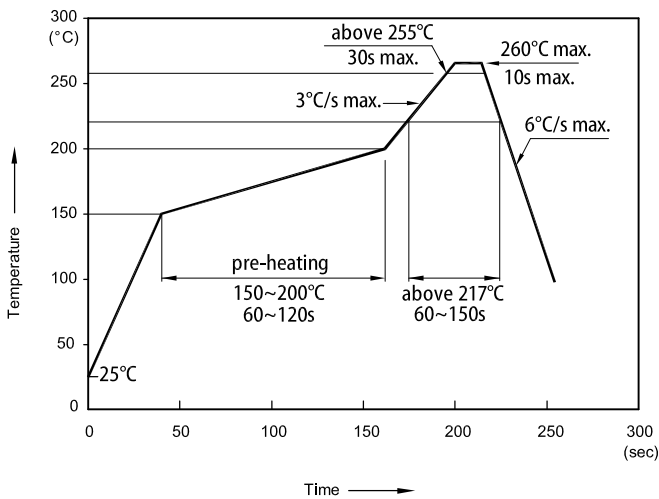

- Notes:
1. Don't cause stress to the LEDs while it is exposed to high temperature.
  2. The maximum number of reflow soldering passes is 2 times.
  3. Reflow soldering is recommended. Other soldering methods are not recommended as they might cause damage to the product.

### TAPE SPECIFICATIONS (units : mm)

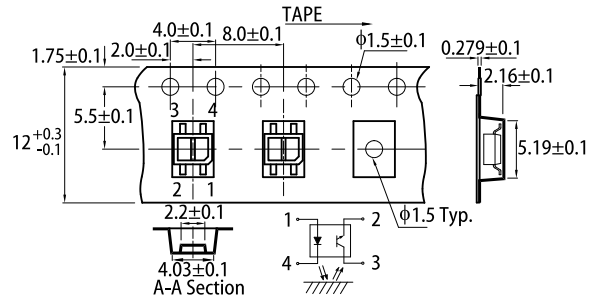

### REEL DIMENSION (units : mm)

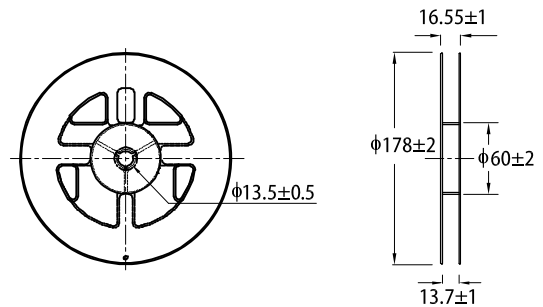

### PACKING & LABEL SPECIFICATIONS

