

# ATC blade fuses



## Features and benefits:

- Industry standard color coding for quick identification of amp rating.
- Tin-plated zinc terminals for corrosion resistance and enhanced conductivity.
- UL Recognized for use in low voltage control circuits.
- Wide -40°C to +100°C operating temperature range meets the needs of extreme environments.
- Lead free, halogen free and RoHS compliant.
- Test points on specific part/package numbers may speed up circuit troubleshooting.

## Product description:

A range of UL® Recognized fast-acting ATC blade fuses for automotive and low-voltage control circuits.

Featuring the same form, fit, and electrical and performance characteristics, ATC fuses are available in a variety of housing materials specific to orderable catalog numbers to meet application needs.



*Powering Business Worldwide*

### Catalog Symbol:

- ATC\_

### Applications:

- Automotive and low-voltage control circuits.

### Specifications:

#### Ratings

- Volts: 32V
- Amps: 1-40A
- Interrupting Rating: 1kA

#### Agency information

- UL Recognized File E56412, Guide JFHR2, UL 248-1 (1-40A).
- ISO 8820-3 / SAE® J1284 / JASO 612 (1-40A).
- SAE J1171 (Ignition Protection) see catalog number tables for specific orderable product.
- RoHS complaint

#### Materials

- Tin-plated zinc terminals
- Tin-plated zinc element
- Housing (see catalog number tables for specific housing materials)
- Housing flammability rating — UL 94

#### Environmental

- Operating Temperature Range -40°C to 100°C, 95% RH non-condensing.
- Storage Temperature Range -5°C to 35°C or lower, 85% RH non-condensing.

### Basic part numbers\*:

Part number (amp)	Body color	Part number (amp)	Body color
ATC-1	Black	ATC-15	Blue
ATC-2	Gray	ATC-20	Yellow
ATC-3	Violet	ATC-25	Clear
ATC-4	Pink	ATC-30	Green
ATC-5	Tan	ATC-35	Blue/Green
ATC-7½	Brown	ATC-40	Orange
ATC-10	Red		

\* See catalog number tables on page four for specific construction, housing material and package availability.

### Electrical Characteristics\*\*:

% of fuse amp rating	Operating time (sec)	
	Min	Max
110	100 Hrs	—
135	0.75	120 (240***)
160	0.25	50
200	0.15	5
350	0.04	0.5
600	0.02	0.1

\*\* At 23°C for all available catalog numbers., Fuse derating with change in ambient temperature = -0.15% / 1°C

\*\*\* 135% Operating time of less than 4 amps.

### Recommended fuse panels, holders and fuseclips:

Catalog No.	Description	Max amps	Lead wire length/size
15600-(poles)-20	ATC Fuse panel in 4- to 20-poles	20A	—
HHC	Yellow, water resistant in-line fuse holder	20A	2x4"/#16
HHD	Black, heavy-duty in-line fuse holder	30A	2x4"/#12
HHF	Black, in-line fuse holder w/cover	20A	2x4"/#14
HHG	Black, heavy-duty in-line fuse holder w/cover	30A	2x4"/#12
HHR	Heavy-duty, water resistant in-line fuse holder	30A	2x5"/#12
BP/HHS-RP	Self-stripping in-line fuse holder	20A	#18 to #14
BP/HHA-RP	Add-a-Fuse	10A	N/A
ATC-FHID	Illuminating in-line fuse holder	20A	2x6"/#16
1A5600 <sup>†</sup>	PCB fuseclip	20A	—
1A5780 <sup>†</sup>	PCB fuseclip	15A	—

<sup>†</sup> See Data Sheet # 2131 for details.

### Dimensions - mm:

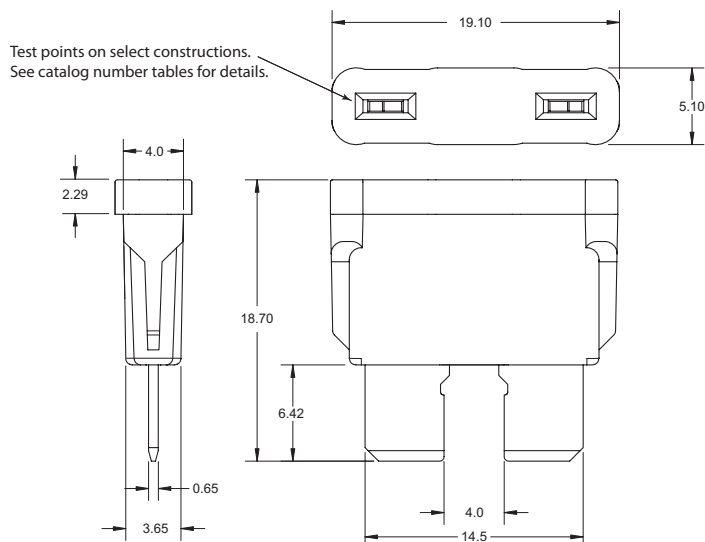

Dimensions shown are basic for all ampacities, constructions and housing materials.

Time-current characteristic curves — average melt - for all fuse constructions/housing materials

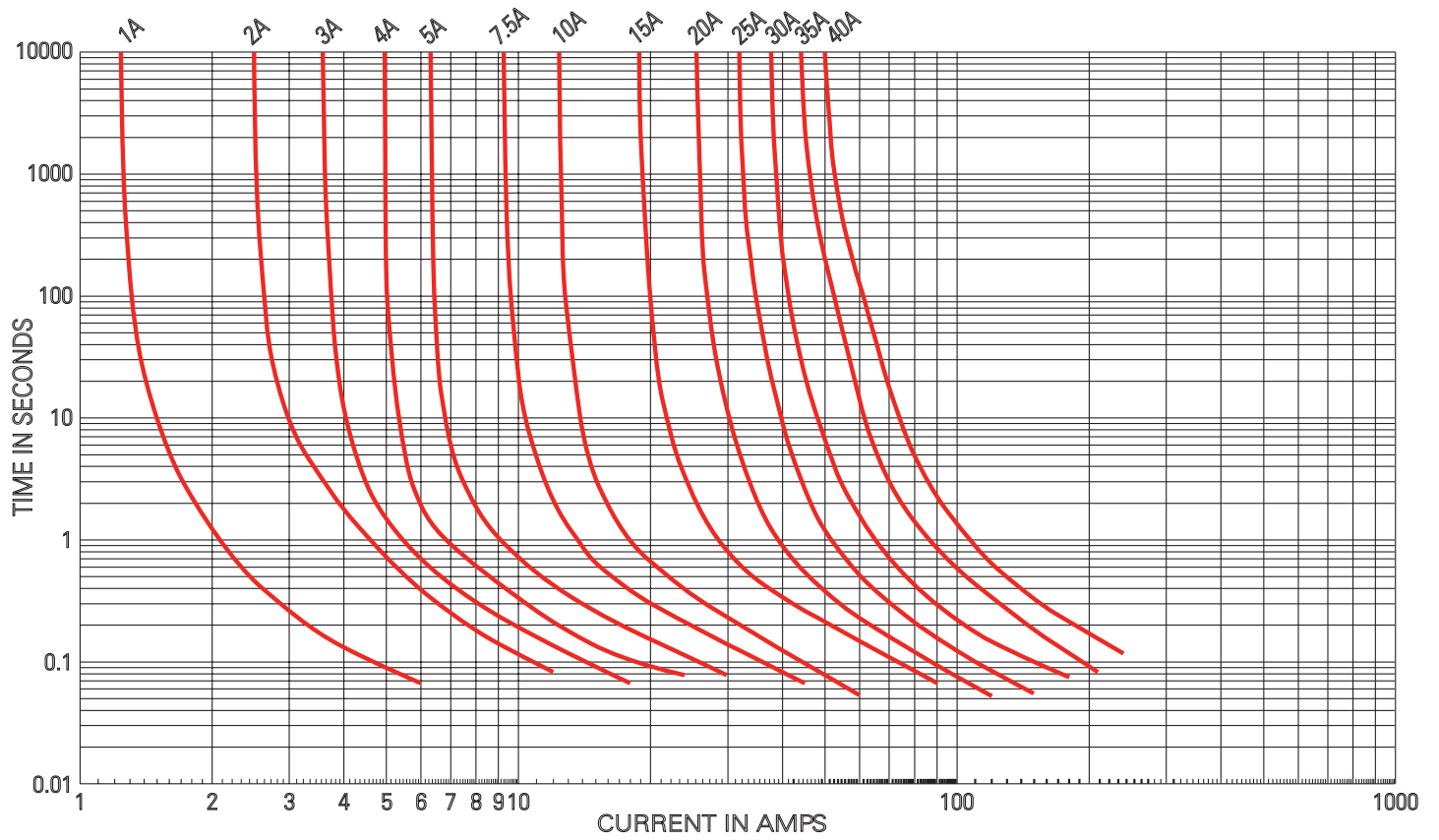

## ATC fuse construction and housing material availability by catalog number

**Table 1. ATC fuse catalog number availability for open body housing without test points\***

Reload	Bulk packs	Blister packs	Assortments/kits/trays	Housing material
ATC-5RLD	BK/ATC-5	BP/ATC-5-RP	BP/ATC-A5-RP (fuse assortment)	Nylon
ATC-7½RLD	BK/ATC-7½	BP/ATC-7½-RP	BP/ATC-AH8-RPP (fuse emergency kit)	Nylon
ATC-10RLD	BK/ATC-10	BP/ATC-10-RP	BP/ATC-AL8-RP (low amp assortment)	Nylon
ATC-15RLD	BK/ATC-15	BP/ATC-15-RP	DIA-1 (diagnostic kit)	Nylon
ATC-20RLD	BK/ATC-20	BP/ATC-20-RP	NO.44 (fuse emergency kit)	Nylon
ATC-25RLD	BK/ATC-25	BP/ATC-25-RP	NO.80 (bulk assortment)	Nylon
ATC-30RLD	BK/ATC-30	BP/ATC-30-RP	NO.95BK (ATC/ATM bulk assortment)	Nylon
—	—	—	NO.53 (ATC/MAX fuse emergency kit)	Nylon
—	—	—	NO.160BK (bulk assortment)	Nylon
—	—	—	NO.225 (tilt bin assortment)	Nylon

\* For specific quantities and amp ratings, see consumer aftermarket product catalog No. 5084.

**Table 2. ATC fuse catalog number availability for closed body housing with test points and SAE J1171 ignition protected**

Reload	Bulk packs*	Blister packs	5-in tins**	Value packs	Assortments	Housing material
—	BK/ATC-1	BP/ATC-1-RP	ATC-1	—	—	Polycarbonate
—	BK/ATC-2	BP/ATC-2-RP	ATC-2	—	—	Polycarbonate
ATC-3RLD	BK/ATC-3	BP/ATC-3-RP	ATC-3	—	—	Polycarbonate
ATC-4RLD	BK/ATC-4	BP/ATC-4-RP	ATC-4	—	—	Polycarbonate
—	BK/ATC-5M	—	ATC-5	VP/ATC-5RP	—	Polycarbonate
—	BK/ATC-7½M	—	ATC-7½	VP/ATC-RP	—	Polycarbonate
—	BK/ATC-10M	—	ATC-10	VP/ATC-RP	—	Polycarbonate
—	BK/ATC-15M	—	ATC-15	VP/ATC-RP	—	Polycarbonate
—	BK-ATC-20M	—	ATC-20	VP/ATC-RP	—	Polycarbonate
—	BK-ATC-25M	—	ATC-25	VP/ATC-RP	—	Polycarbonate
—	BK-ATC-30M	—	ATC-30	VP/ATC-RP	—	Polycarbonate
—	BK-ATC-35	—	ATC-35	—	—	Polysulfone
—	BK-ATC-40	BP/ATC-40-RP	ATC-40	—	—	Polyethersulfone
—	—	—	—	—	CDY10TRY-ATC (fuse tray)***	—
—	—	—	—	—	NO.290***	—

\* 2000 fuses per pack.

\*\* 5 fuses per tin.

\*\*\* Contains one 5-in tin each of ATC 3, 4, 5, 7-1/2, 10, 15, 20, 25, 30, 35 and 40A. See poly material column for details on the fuses in each tin of this assortment.

The only controlled copy of this data sheet is the electronic read-only version located on the Eaton network drive. All other copies of this document are by definition uncontrolled. This bulletin is intended to clearly present comprehensive product data and provide technical information that will help the end user with design applications. Eaton reserves the right, without notice, to change design or construction of any products and to discontinue or limit distribution of any products. Eaton also reserves the right to change or update, without notice, any technical information contained in this bulletin. Once a product has been selected, it should be tested by the user in all possible applications.

**Eaton**  
1000 Eaton Boulevard  
Cleveland, OH 44122  
Eaton.com

Bussmann Division  
114 Old State Road  
Ellisville, MO 63021  
United States  
Eaton.com/bussmannseries

© 2015 Eaton  
All Rights Reserved  
Printed in USA  
Publication No. 2009 — BU-SB14727  
October 2015

Eaton and Bussmann are valuable trademarks of Eaton in the U.S. and other countries. You are not permitted to use the Eaton trademarks without prior written consent of Eaton. SAE is a registered trademark of the Society of Automotive Engineers. UL is a registered trademark of the Underwriters Laboratories, Inc.

For Eaton's Bussmann series product information, call **1-855-287-7626** or visit: **Eaton.com/bussmannseries**

Follow us on social media to get the latest product and support information.

