

AT25QL641

SPI Serial Flash Memory with Dual I/O, Quad I/O, QPI Support

Features

- Single 1.7V - 2.0V Supply
- 64 Mbit (8 x 8 Mbit) Flash Memory
- Serial Peripheral Interface (SPI) and Quad Peripheral Interface (QPI) compatible
 - Supports SPI Modes 0 and 3
 - Supports Dual Output Read and Quad I/O program and read
 - Supports QPI program and read
 - 133 MHz maximum operating frequency
 - Clock-to-Output (t_{V1}) of 6 ns
 - Up to 66 MB/s continuous data transfer rate
- Quad enabled (factory default setting: see [Section 7.7](#))
- Full chip erase
- Flexible, optimized erase architecture for code and data storage applications
 - 0.6 ms typical Page Program (256 Bytes) time
 - 60 ms typical 4 Kbyte Block Erase time
 - 200 ms typical 32 Kbyte Block Erase time
 - 350 ms typical 64 Kbyte Block Erase time
- Hardware controlled locking of Status registers via \overline{WP} pin
- 4 Kbit secured One-Time Programmable (OTP) security register
- Hardware write protection
- Serial Flash Discoverable Parameters (SFDP) register
- Flexible programming
 - Byte/page program (1 to 256 Bytes)
 - Dual or quad input byte/page program (1 to 256 Bytes)
- Erase/program suspend and resume
- JEDEC standard manufacturer and device ID read methodology
- Low power dissipation
 - 2 μ A Deep Power-Down (DPD) current (typical)
 - 10 μ A Standby current (typical)
 - 5 mA Active read current (typical)
- Endurance: 100,000 program/erase cycles (4KB, 32KB or 64KB blocks)
- Data Retention: 20 years
- Industrial temperature range: -40 °C to +85 °C
- Industry standard green (Pb/Halide-free/RoHS compliant) package options
 - 8-pad DFN (6 x 5 x 0.6 mm)
 - 8-ball WLCSP (dBGA)

Contents

Features	1
Figures	4
Tables	6
1. Introduction	7
2. Pinouts and Pin Descriptions	8
3. Block Diagram	10
4. Memory Array	11
5. Device Operation	12
5.1 Standard SPI Operation	12
5.2 Dual SPI Operation	12
5.3 Quad SPI Operation	12
5.4 QPI Operation	12
6. Write Protection	13
6.1 Write Protect Features	13
7. Status Registers	14
7.1 Busy	14
7.2 Write Enable Latch (WEL)	14
7.3 Block Protect Bits (BP2, BP1, BP0)	14
7.4 Top/Bottom Block Protect (TB)	14
7.5 Sector/Block Protect (SEC)	15
7.6 Status Register Protect (SRP1, SRP0)	15
7.7 Quad Enable (QE)	15
7.8 Complement Protect (CMP)	15
7.9 Erase/Program Suspend Status (SUS)	16
8. Commands	18
8.1 Command Tables	19
8.2 Write Enable (06h)	22
8.3 Write Enable for Volatile Status Register (50h)	23
8.4 Write Disable (04h)	23
8.5 Read Status Register-1 (05h) and Read Status Register-2 (35h)	24
8.6 Write Status Register (01h)	25
8.7 Write Status Register-2 (31h)	26
8.8 Set Read Parameters (C0h)	27
8.9 Read Data (03h)	28
8.10 Fast Read (0Bh)	29
8.11 Fast Read Dual Output (3Bh)	30
8.12 Fast Read Quad Output (6Bh)	31
8.13 Fast Read Dual I/O (BBh)	32
8.14 Fast Read Quad I/O (EBh)	34
8.15 Page Program (02h)	36
8.16 Quad Page Program (33h)	38
8.17 4 Kbyte Block Erase (20h)	40
8.18 32 Kbyte Block Erase (52h)	41
8.19 64 Kbyte Block Erase (D8h)	42

8.20	Chip Erase (C7h / 60h)	43
8.21	Erase / Program Suspend (75h)	43
8.22	Erase / Program Resume (7Ah)	45
8.23	Deep Power-Down (B9h)	46
8.24	Release Deep Power-Down / Device ID (ABh)	47
8.25	Read Manufacturer / Device ID I/O (90h)	48
8.26	Read Manufacturer / Device ID Dual I/O (92h)	50
8.27	Read Manufacturer / Device ID Quad I/O (94h)	51
8.28	JEDEC ID (9Fh)	52
8.29	Enable QPI (38h)	53
8.30	Disable QPI (FFh)	53
8.31	Word Read Quad I/O (E7h)	54
8.32	Set Burst with Wrap (77h)	56
8.33	Burst Read with Wrap (0Ch)	57
8.34	Enable Reset (66h) and Reset (99h)	58
8.35	Read Serial Flash Discovery Parameter (5Ah)	59
8.36	Enter Secured OTP (B1h)	67
8.37	Exit Secured OTP (C1h)	67
8.38	Read Security Register (2Bh)	68
8.39	Write Security Register (2Fh)	69
8.40	4 Kbit Secured OTP	69
9.	Electrical Characteristics	70
9.1	DC Electrical Characteristics	71
9.2	AC Measurement Conditions	71
9.3	AC Electrical Characteristics	72
9.4	Input Timing	73
9.5	Output Timing	73
9.6	Hold Timing	74
10.	Ordering Information	75
10.1	Ordering Code Detail	75
11.	Packaging Information	76
11.1	8MA1 – UDFN	76
11.2	8-WLCSP — die Ball Grid Array	77
12.	Revision History	78
12.1	Errata:	79

Figures

Figure 1. 8-UDFN (Top View)	8
Figure 2. 8-WLCSP (Bottom View)	8
Figure 3. AT25QL641 Block Diagram	10
Figure 4. Memory Architecture Diagram	11
Figure 5. Write Enable Command for SPI Mode (left) and QPI Mode (right)	22
Figure 6. Write Enable for Volatile Status Register Command for SPI Mode (left) and QPI Mode (right)	23
Figure 7. Write Disable Command for SPI Mode (left) and QPI Mode (right)	23
Figure 8. Read Status Register Command (SPI Mode)	24
Figure 9. Read Status Register Command (QPI Mode)	24
Figure 10. Write Status Register Command (SPI Mode)	25
Figure 11. Write Status Register Command (QPI Mode)	25
Figure 12. Write Status Register-2 Command (SPI Mode)	26
Figure 13. Write Status Register-2 Command (QPI Mode)	26
Figure 14. Set Read Parameters Command (QPI Mode)	27
Figure 15. Read Data Command	28
Figure 16. Fast Read Command (SPI Mode)	29
Figure 17. Fast Read Command (QPI Mode)	29
Figure 18. Fast Read Dual Output Command (SPI Mode)	30
Figure 19. Fast Read Quad Output Command (SPI Mode)	31
Figure 20. Fast Read Dual I/O Command (initial command or previous M7-0 ≠ Axh)	32
Figure 21. Fast Read Dual I/O Command (previous M7-0 = Axh)	33
Figure 22. Fast Read Quad I/O Command (Initial command or previous M7-0 ≠ Axh, SPI mode)	34
Figure 23. Fast Read Quad I/O Command (previous M7-0 = Axh, SPI mode)	34
Figure 24. Fast Read Quad I/O Command (Initial command or previous M7-0 ≠ Axh, QPI mode)	35
Figure 25. Page Program Command (SPI Mode)	36
Figure 26. Page Program Command (QPI Mode)	37
Figure 27. Quad Page Program Command (SPI mode)	38
Figure 28. Quad Page Program Command (QPI mode)	39
Figure 29. Block Erase Command (SPI Mode)	40
Figure 30. Block Erase Command (QPI Mode)	40
Figure 31. 32 KB Block Erase Command (SPI Mode)	41
Figure 32. 32 KB Block Erase Command (QPI Mode)	41
Figure 33. 64 KByte Block Erase Command (SPI Mode)	42
Figure 34. 64 KByte Block Erase Command (QPI Mode)	42
Figure 35. Chip Erase Command for SPI Mode (left) and QPI Mode (right)	43
Figure 36. Erase Suspend Command (SPI Mode)	44
Figure 37. Erase Suspend Command (QPI Mode)	44
Figure 38. Erase / Program Resume Command (SPI Mode)	45
Figure 39. Erase / Program Resume Command (QPI Mode)	45
Figure 40. Deep Power-Down Command (SPI Mode)	46
Figure 41. Deep Power-Down Command (QPI Mode)	46
Figure 42. Release Power-Down Command (SPI Mode)	47
Figure 43. Release Power-Down Command (QPI Mode)	47
Figure 44. Release Power-Down / Device ID Command (SPI Mode)	48
Figure 45. Read Manufacturer/ Device ID Command (SPI Mode)	49
Figure 46. Read Manufacturer/ Device ID Command (QPI Mode)	49
Figure 47. Read Dual Manufacturer/ Device ID Dual I/O Command (SPI Mode)	50

Figure 48. Read Quad Manufacturer/ Device ID Quad I/O Command (SPI Mode)51

Figure 49. Read JEDEC ID Command (SPI Mode)52

Figure 50. Read JEDEC ID Command (QPI Mode)52

Figure 51. Enable QPI Command (SPI Mode only)53

Figure 52. Disable QPI Command for QPI Mode53

Figure 53. Word Read Quad I/O Command (Initial command or previous set M7-0 ≠ Axh, SPI Mode)54

Figure 54. Word Read Quad I/O Command (Previous command set M7-0 = Axh, SPI Mode)54

Figure 55. Set Burst with Wrap Command Sequence56

Figure 56. Burst Read with Wrap Command (QPI Mode)57

Figure 57. Enable Reset and Reset Command (SPI Mode)58

Figure 58. Enable Reset and Reset Command (QPI Mode)58

Figure 59. Read SFDP Register Command59

Figure 60. Enter Secured OTP Command for SPI Mode (left) and QPI Mode (right)67

Figure 61. Exit Secured OTP command for SPI Mode (left) and QPI Mode (right)67

Figure 62. Read Security Register Command (SPI Mode)68

Figure 63. Read Security Register Command (QPI Mode)68

Figure 64. Write Security Register Command for SPI Mode (left) and QPI Mode (right)69

Figure 65. Power-Up Timing and Voltage Levels70

Figure 66. AC Measurement I/O Waveform71

Tables

Table 1. Pin Descriptions	8
Table 2. Status Register-1	14
Table 3. Status Register-2	14
Table 4. Protection Types	15
Table 5. Status Register Memory Protection (CMP = 0)	16
Table 6. Status Register Memory Protection (CMP = 1)	17
Table 7. Manufacturer and Device Identification	18
Table 8. Command Set Table 1 (SPI Commands)	19
Table 9. Command Set Table 2 (Dual SPI Commands)	20
Table 10. Command Set Table 3 (Quad SPI Commands)	20
Table 11. Command Set Table 4 (QPI Commands)	21
Table 12. Encoding of P[5:4] Bits	27
Table 13. Encoding of P[1:0] Bits	27
Table 14. Encoding of the W6 - W4 Wrap Bits	56
Table 15. SFDP Signature and Headers	60
Table 16. SFDP Parameters Table 1	61
Table 17. SFDP Parameters Table 2	66
Table 18. Security Register Definition	68
Table 19. Secure OTP Address Space	69
Table 20. Absolute Maximum Ratings	70
Table 21. Operating Ranges	70
Table 22. Endurance and Data Retention	70
Table 23. Power-up Timing and Write Inhibit Threshold	70
Table 24. DC Electrical Characteristics	71
Table 25. AC Measurement Conditions	71
Table 26. AC Electrical Characteristics	72

1. Introduction

The AT25QL641 is a serial interface Flash memory device designed for use in a wide variety of high-volume consumer based applications in which program code is shadowed from Flash memory into embedded or external RAM for execution. The flexible erase architecture of the AT25QL641 is ideal for data storage as well, eliminating the need for additional data storage devices.

The erase block sizes of the AT25QL641 have been optimized to meet the needs of today's code and data storage applications. By optimizing the size of the erase blocks, the memory space can be used much more efficiently. Because certain code modules and data storage segments must reside by themselves in their own erase regions, the wasted and unused memory space that occurs with large block erase Flash memory devices can be greatly reduced. This increased memory space efficiency allows additional code routines and data storage segments to be added while still maintaining the same overall device density.

SPI clock frequencies of up to 133 MHz are supported, allowing equivalent clock rates of 266 MHz for Dual Output and 532 MHz for Quad Output when using the QPI and Fast Read Dual/Quad I/O commands. The AT25QL641 array is organized into 32,768 programmable pages of 256 bytes each. Up to 256 bytes can be programmed at a time using the Page Program commands. Pages can be erased 4 kB block, 32 kB block, 64 kB block, or the entire chip.

The devices operate on a single 1.7 V to 1.95 V power supply with current consumption as low as 5 mA active and 2 μ A for Deep Power-Down (DPD). All devices offered in space-saving packages. The device supports JEDEC standard manufacturer and device identification with a 4 kbit secured OTP.

The physical block size for this device is 8 Mbit.

2. Pinouts and Pin Descriptions

Figure 1 and Figure 2 show the available package types.

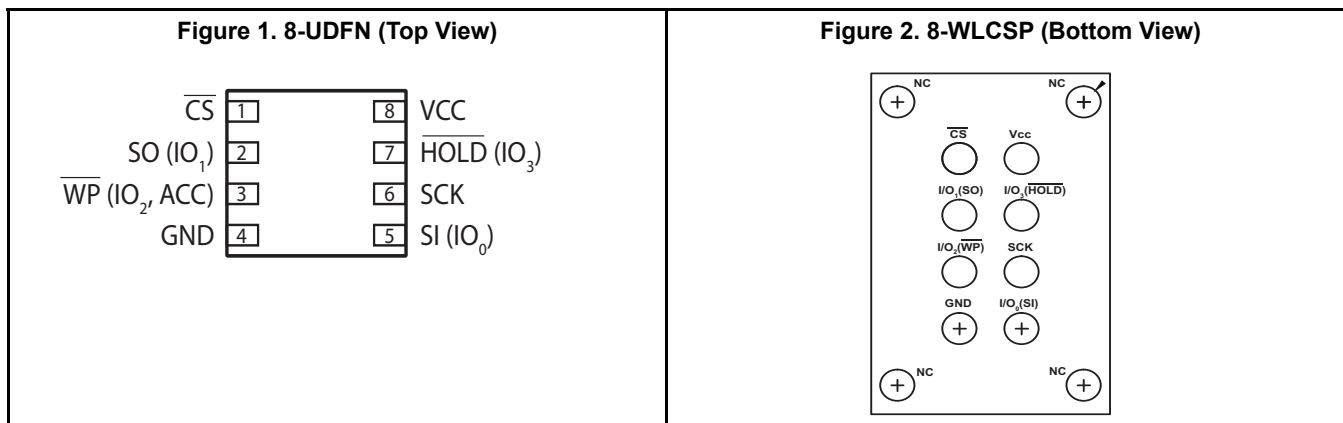

During all operations, V_{CC} must be held stable and within the specified valid range: $V_{CC}(\text{min})$ to $V_{CC}(\text{max})$.

All of the input and output signals must be held high or low (according to voltages of V_{IH} , V_{OH} , V_{IL} or V_{OL}).

Table 1. Pin Descriptions

Symbol	Name and Function	Asserted State	Type
\overline{CS}	<p>CHIP SELECT</p> <p>When this input signal is high, the device is deselected and serial data output pins are at high impedance. Unless an internal program, erase or write status register cycle is in progress, the device remains in the standby power mode (this is not the deep power down mode). Driving the Chip Select (\overline{CS}) low enables the device, placing it in the active power mode. After power-up, a falling edge of Chip Select (\overline{CS}) is required prior to the start of any command.</p>	Low	Input
SCK	<p>SERIAL CLOCK</p> <p>This input signal provides the timing for the serial interface. Commands, addresses, or data present at serial data input are latched on the rising edge of Serial Clock (SCK). Data are shifted out on the falling edge of the SCK.</p>	-	Input
SI (I/O_0)	<p>SERIAL INPUT</p> <p>The SI pin is used to shift data into the device. The SI pin is used for all data input, including command and address sequences. Data on the SI pin is always latched in on the rising edge of SCK.</p> <p>With the Dual-Output and Quad-Output Read commands, the SI Pin becomes an output pin (I/O_0) in conjunction with other pins to allow two or four bits of data on (I/O_{3-0}) to be clocked in on every falling edge of SCK</p> <p>To maintain consistency with the SPI nomenclature, the SI (I/O_0) pin is referenced as the SI pin unless specifically addressing the Dual-I/O and Quad-I/O modes in which case it is referenced as I/O_0.</p> <p>Data present on the SI pin is ignored whenever the device is deselected (\overline{CS} is deasserted).</p>	-	Input/Output

Table 1. Pin Descriptions (Continued)

Symbol	Name and Function	Asserted State	Type
SO (I/O ₁)	<p>SERIAL OUTPUT</p> <p>The SO pin is used to shift data out from the device. Data on the SO pin is always clocked out on the falling edge of SCK.</p> <p>With the Dual-Output Read commands, the SO Pin remains an output pin (I/O₀) in conjunction with other pins to allow two bits of data on (I/O_{1,0}) to be clocked in on every falling edge of SCK.</p> <p>To maintain consistency with the SPI nomenclature, the SO (I/O₁) pin is referenced as the SO pin unless specifically addressing the Dual-I/O modes in which case it is referenced as I/O₁. The SO pin is in a high-impedance state whenever the device is deselected (\overline{CS} is deasserted).</p>	-	Input/Output
\overline{WP} (I/O ₂)	<p>WRITE PROTECT</p> <p>The Write Protect (\overline{WP}) pin can be used to protect the Status Register against data modification. Used with the Status Register's Block Protect (SEC, TB, BP2, BP1 and BP0) bits and Status Register Protect (SRP) bits, a portion or the entire memory array can be hardware protected. The \overline{WP} pin is active low. When the QE bit of Status Register-2 is set for Quad I/O, the \overline{WP} pin (Hardware Write Protect) function is not available because this pin is used for IO₂. The \overline{WP} pin does not have an internal pull-up; thus, it must be either driven or, if not used, pulled up with an external resistor to V_{CC}.</p>	-	Input/Output
\overline{HOLD} (I/O ₃)	<p>HOLD</p> <p>The \overline{HOLD} pin is used to temporarily pause serial communication without deselecting or resetting the device. While the \overline{HOLD} pin is asserted, transitions on the SCK pin and data on the SI pin are ignored, and the SO pin is placed in a high-impedance state.</p> <p>The \overline{CS} pin must be asserted, and the SCK pin must be in the low state in order for a Hold condition to start. A Hold condition pauses serial communication only and does not have an effect on internally self-timed operations such as a program or erase cycle.</p> <p>With the Quad-Input Byte/Page Program command, the \overline{HOLD} pin becomes an input pin (I/O₃) and with other pins, allows four bits (on I/O_{3,0}) of data to be clocked in on every rising edge of SCK. With the Quad-Output Read commands, the \overline{HOLD} Pin becomes an output pin (I/O₃) in conjunction with other pins to allow four bits of data on (I/O_{3,0}) to be clocked in on every falling edge of SCK. To maintain consistency with SPI nomenclature, the \overline{HOLD} (I/O₃) pin is referenced as the \overline{HOLD} pin unless specifically addressing the Quad-I/O modes, in which case it is referenced as I/O₃. The \overline{HOLD} pin does not have an internal pull-up; thus, it must be either driven or, if not used, pulled up with an external resistor to V_{CC}.</p>	-	Input/Output
V _{CC}	<p>DEVICE POWER SUPPLY</p> <p>V_{CC} is the supply voltage. It is the single voltage used for all device functions including read, program, and erase. The V_{CC} pin is used to supply the source voltage to the device. Operations at invalid V_{CC} voltages may produce spurious results and should not be attempted.</p>	-	Power
GND	<p>GROUND</p> <p>V_{SS} is the reference for the V_{CC} supply voltage. The ground reference for the power supply. GND should be connected to the system ground.</p>	-	Power

3. Block Diagram

Figure 3 shows a block diagram of the AT25QL641 serial Flash.

Figure 3. AT25QL641 Block Diagram

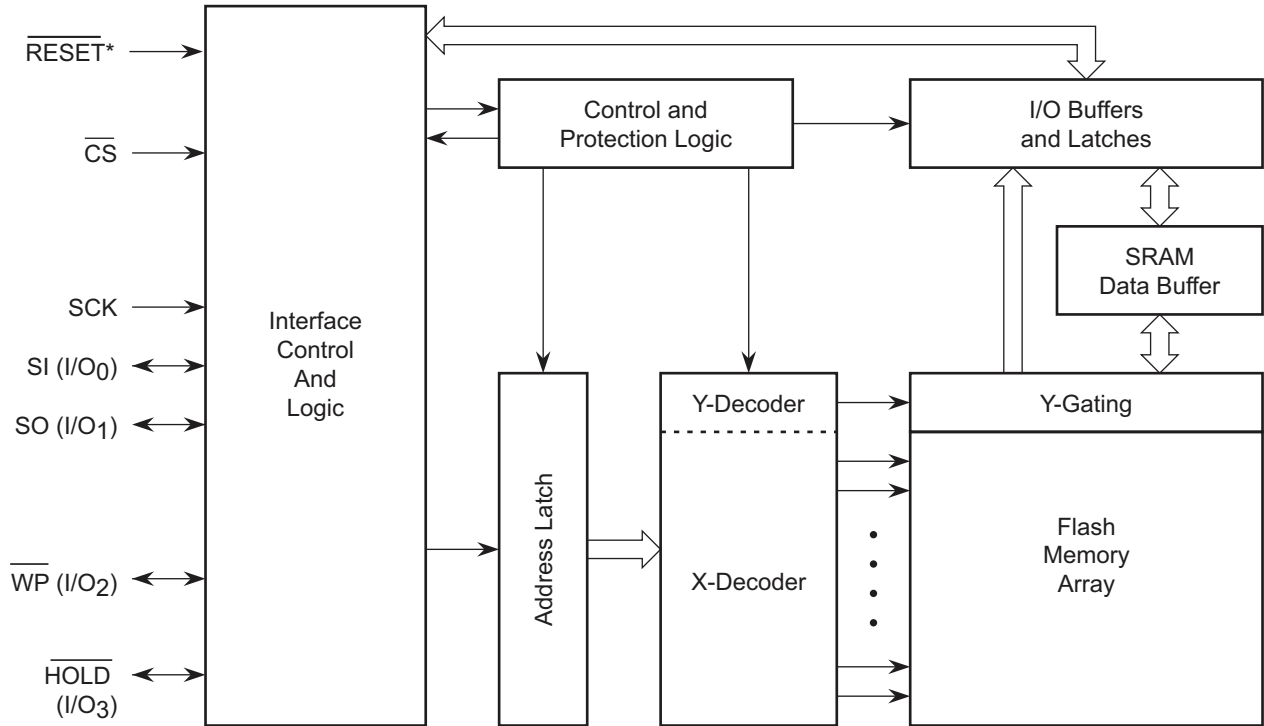

Note: I/O₃₋₀ pin naming convention is used for Dual-I/O and Quad-I/O commands.

* Hardware-controlled RESET available ONLY on packages with greater than eight pins.

4. Memory Array

To provide the greatest flexibility, the memory array of the AT25QL641 can be erased in four levels of granularity including a full chip erase. The size of the erase blocks is optimized for both code and data storage applications, allowing both code and data segments to reside in their own erase regions. Figure 4 shows each erase level.

Figure 4. Memory Architecture Diagram

Block Erase Detail				Page Program Detail	
64KB	32KB	4KB	Block Address Range	1-256 byte	Page Address Range
64KB	32KB	4KB	7FFFFFh – 7FF000h	256 bytes	7FFFFFh – 7FFF00h
		4KB	7FEFFFh – 7FE000h	256 bytes	7FEFFFh – 7FEE00h
		4KB	7FDFFFh – 7FD000h	256 bytes	7FDFFFh – 7FD000h
		4KB	7FCFFFh – 7FC000h	256 bytes	7FCFFFh – 7FC000h
		4KB	7FBFFFh – 7FB000h	256 bytes	7FBFFFh – 7FB000h
		4KB	7FAFFFh – 7FA000h	256 bytes	7FAFFFh – 7FA000h
		4KB	7F9FFFh – 7F9000h	256 bytes	7F9FFFh – 7F9000h
		4KB	7F8FFFh – 7F8000h	256 bytes	7F8FFFh – 7F8000h
	32KB	4KB	7F7FFFh – 7F7000h	256 bytes	7F7FFFh – 7F7000h
		4KB	7F6FFFh – 7F6000h	256 bytes	7F6FFFh – 7F6000h
		4KB	7F5FFFh – 7F5000h	256 bytes	7F5FFFh – 7F5000h
		4KB	7F4FFFh – 7F4000h	256 bytes	7F4FFFh – 7F4000h
		4KB	7F3FFFh – 7F3000h	256 bytes	7F3FFFh – 7F3000h
		4KB	7F2FFFh – 7F2000h	256 bytes	7F2FFFh – 7F2000h
		4KB	7F1FFFh – 7F1000h	256 bytes	7F1FFFh – 7F1000h
		4KB	7F0FFFh – 7F0000h	256 bytes	7F0FFFh – 7F0000h
64KB	32KB	4KB	7EFFFh – 7EF000h	256 bytes	7EFFFh – 7FEF00h
		4KB	7EFFFFh – 7EE000h	256 bytes	7EFFFFh – 7FEE00h
		4KB	7EDFFFh – 7ED000h	256 bytes	7EDFFFh – 7FED00h
		4KB	7ECFFFh – 7EC000h	256 bytes	7ECFFFh – 7FEC00h
		4KB	7EBFFFh – 7EB000h	256 bytes	7EBFFFh – 7FEB00h
		4KB	7EAFh – 7EA000h	256 bytes	7EAFh – 7FEA00h
		4KB	7E9FFFh – 7E9000h	256 bytes	7E9FFFh – 7FE900h
		4KB	7E8FFFh – 7E8000h	256 bytes	7E8FFFh – 7FE800h
	32KB	4KB	7E7FFFh – 7E7000h	:	
		4KB	7E6FFFh – 7E6000h		
		4KB	7E5FFFh – 7E5000h		
		4KB	7E4FFFh – 7E4000h		
		4KB	7E3FFFh – 7E3000h	256 bytes	0017FFh – 001700h
		4KB	7E2FFFh – 7E2000h	256 bytes	0016FFh – 001600h
		4KB	7E1FFFh – 7E1000h	256 bytes	0015FFh – 001500h
		4KB	7E0FFFh – 7E0000h	256 bytes	0014FFh – 001400h
64KB	32KB	4KB	00FFFFh – 00F000h	256 bytes	0013FFh – 001300h
		4KB	00EFFFh – 00E000h	256 bytes	0012FFh – 001200h
		4KB	00DFFFh – 00D000h	256 bytes	0011FFh – 001100h
		4KB	00CFFFh – 00C000h	256 bytes	0010FFh – 001000h
		4KB	00BFFFh – 00B000h	256 bytes	000FFFh – 000F00h
		4KB	00AFFh – 00A000h	256 bytes	000EFFh – 000E00h
		4KB	009FFFh – 009000h	256 bytes	000DFFh – 000D00h
		4KB	008FFFh – 008000h	256 bytes	000CFFh – 000C00h
	32KB	4KB	007FFFh – 007000h	256 bytes	000BFFh – 000B00h
		4KB	006FFFh – 006000h	256 bytes	000AFFh – 000A00h
		4KB	005FFFh – 005000h	256 bytes	0009FFh – 000900h
		4KB	004FFFh – 004000h	256 bytes	0008FFh – 000800h
		4KB	003FFFh – 003000h	256 bytes	0007FFh – 000700h
		4KB	002FFFh – 002000h	256 bytes	0006FFh – 000600h
		4KB	001FFFh – 001000h	256 bytes	0005FFh – 000500h
		4KB	000FFFh – 000000h	256 bytes	0004FFh – 000400h

5. Device Operation

5.1 Standard SPI Operation

The AT25QL641 features a serial peripheral interface on four signals: Serial Clock (SCK), Chip Select ($\overline{\text{CS}}$), Serial Data Input (SI) and Serial Data Output (SO). Standard SPI commands use the SI input pin to serially write commands, addresses or data to the device on the rising edge of SCK. The SO output pin is used to read data or status from the device on the falling edge of SCK.

SPI bus operation Modes 0 (0, 0) and 3 (1, 1) are supported. The primary difference between Mode 0 and Mode 3 concerns the normal state of the SCK signal when the SPI bus master is in standby and data is not being transferred to the Serial Flash. For Mode 0 the SCK signal is normally low on the falling and rising edges of $\overline{\text{CS}}$. For Mode 3 the SCK signal is normally high on the falling and rising edges of $\overline{\text{CS}}$.

5.2 Dual SPI Operation

The AT25QL641 supports Dual SPI operation. This command allows data to be transferred to or from the device at two times the rate of the standard SPI. The Dual Read command is ideal for quickly downloading code to RAM upon power-up (code-shadowing) or for execute-in-place (XiP) non-speed-critical code directly from the SPI bus. When using Dual SPI commands the SI and SO pins become bidirectional I/O pins; I/O₀ and I/O₁.

5.3 Quad SPI Operation

The AT25QL641 supports Quad SPI operation. This command allows data to be transferred to or from the device at four times the rate of the standard SPI. The Quad Read command offers a significant improvement in continuous and random access transfer rates allowing fast code-shadowing to RAM or execution directly from the SPI bus. When using the Quad SPI command the SI and SO pins become bidirectional I/O₀ and I/O₁, and the $\overline{\text{WP}}$ and $\overline{\text{HOLD}}$ pins become I/O₂ and I/O₃, respectively. Quad SPI commands require the non-volatile Quad Enable bit (QE) in Status Register-2 to be set. The AT25QL641 device ships with the QE bit set.

5.4 QPI Operation

When using QPI commands, the SI and SO pins become bidirectional I/O₀ and I/O₁, and the $\overline{\text{WP}}$ and $\overline{\text{HOLD}}$ pins become I/O₂ and I/O₃ respectively.

The typical SPI protocol requires that the byte-long command code being shifted into the device only via SI pin in eight serial clocks. The QPI mode utilizes all four I/O pins to input the command code, thus only two serial clocks are required. This can significantly reduce the SPI command overhead and improve system performance in an XiP environment. Standard/ Dual/ Quad SPI mode and QPI mode are exclusive. Only one mode can be active at any given time, The Enable QPI (38h) and Disable QPI (FFh) commands are used to switch between these two modes. Upon power-up or after software reset using Reset (99h) command, the default state of the device is Standard/Dual/Quad SPI mode.

6. Write Protection

To protect inadvertent writes by the possible noise, several means of protection are applied to the Flash memory.

6.1 Write Protect Features

The write protect features are:

- While Power-on reset, all operations are disabled and no command is recognized.
- An internal time delay of t_{PUW} can protect the data against inadvertent changes while the power supply is outside the operating specification. This includes the Write Enable, Page Program, Block Erase, Chip Erase, Write Security Register and the Write Status Register commands.
- For data changes, Write Enable command must be issued to set the Write Enable Latch (WEL) bit to 0. Power-up, Completion of Write Disable, Write Status Register, Page Program, Block Erase and Chip Erase are subjected to this condition.
- Status Register protect (SRP) and Block protect (SEC, TB, BP2, BP1, and BP0) bits may be used to configure a portion of the memory as read-only (software protection).
- The Write Protect (\overline{WP}) pin can be used to change the Status register (hardware control).
- The Deep Power-Down (DPD) mode provides extra protection from unexpected data changes as all commands are ignored under this status except for the Release from Deep Power-Down command.

7. Status Registers

The Read Status Register command can be used to provide status on the availability of the Flash memory array, if the device is write enabled or disabled, the state of write protection, and the Quad SPI setting. The Write Status Register command can be used to configure the devices write protection features and Quad SPI setting. Write access to the Status register is controlled, in some cases, by the \overline{WP} pin.

Table 2. Status Register-1

S7	S6	S5	S4	S3	S2	S1	S0
SRP	SEC	TB	BP2	BP1	BP0	WEL	BUSY
Status Register Protect 0 (Non-Volatile)	Sector Protect (Non-Volatile)	Top/Bottom Write Protect (Non-Volatile)	Block Protect (Non-Volatile)	Block Protect (Non-Volatile)	Block Protect (Non-Volatile)	Write Enable Latch	Erase or Write in Progress

Table 3. Status Register-2

S15	S14	S13	S12	S11	S10	S9	S8
SUS	CMP	(R)	(R)	(R)	(R)	QE	SRP1
Suspend Status	Complement Protect (Non-Volatile)	Reserved	Reserved	Reserved	Reserved	Quad Enable (Non-Volatile)	Register Protect 1 (Non-Volatile)

7.1 Busy

BUSY is a read-only bit (S0) that is set to a 1 state when the device is executing a Page Program, Erase, Write Status Register or Write Security Register command. During this time, the device ignores further command except for the Read Status Register and Erase / Program Suspend command (see t_W , t_{PP} , t_{SE} , t_{BE1} , t_{BE2} and t_{CE} in [Table 26, AC Electrical Characteristics](#)). When the Program, Erase, Write Status Register or Write Security Register command has completed, hardware clears the BUSY bit (to a 0 state), indicating the device is ready for further commands.

7.2 Write Enable Latch (WEL)

Write Enable Latch (WEL) is a read only bit in status register (S1) that is set to a 1 after executing a Write Enable command. The WEL status bit is cleared to a 0 when device is write disabled. A write disable state occurs upon power-up or after any of the following commands: Write Disable, Page Program, Erase and Write Status Register.

7.3 Block Protect Bits (BP2, BP1, BP0)

The Block Protect Bits (BP2, BP1, BP0) are non-volatile read/write bits (S4, S3, and S2) that provide write protection control and status. Block protect bits can be set using the Write Status Register Command (see t_W in [Table 26, AC Electrical Characteristics](#)). All, none or a portion of the memory array can be protected from Program and Erase commands (see [Table 5](#) and [Table 6](#)). The factory default setting for the Block Protection Bits is 0, none of the array protected.

7.4 Top/Bottom Block Protect (TB)

The Top/Bottom bit (TB) is non-volatile bits (S5) that controls if the Block Protect Bits (BP2, BP1, BP0) protect from the Top (TB = 0) or the Bottom (TB = 1) of the array, as shown in [Table 5](#) and [Table 6](#). The factory default setting is TB = 0. The TB bit can be set with the Write Status Register Command depending on the state of the SRP0, SRP1, and WEL bits.

7.5 Sector/Block Protect (SEC)

The Sector protect bit (SEC) is a non-volatile bit (S6) that controls if the Block Protect Bits (BP2, BP1, BP0) protect 4 kB Sectors (SEC = 1) or 64 kB blocks (SEC = 0) in the Top (TB = 0) or the Bottom (TB = 1) of the array as shown in Table 5 and Table 6. The default setting is SEC = 0.

7.6 Status Register Protect (SRP1, SRP0)

The Status Register Protect bits (SRP1 and SRP0) are non-volatile read/write bits in the status register (S8 and S7). The SRP bits control the method of write protection: software protection, hardware protection, power supply lock-down or one time programmable (OTP) protection.

Table 4. Protection Types

SRP1	SRP0	WP	Type of Protection	Description
0	0	X	Software Protection	\overline{WP} pin no control. The register can be written to after a Write Enable command, WEL = 1 (factory default)
0	1	0	Hardware Protected	When \overline{WP} pin is low the Status Register locked and can not be written to.
0	1	1	Hardware Unprotected	When \overline{WP} pin is high the Status register is unlocked and can be written to after a Write Enable command, WEL = 1.
1	0	X	Power Supply Lock-Down	Status Register is protected and cannot be written to again until the next power down, power-up cycle. ¹
1	1	X	One Time Program	Status Register is permanently protected and cannot be written to.

Note: 1. When SRP1, SRP0 = (1,0), a power-down, power-up cycle changes SRP1, SRP0 to the (0,0) state.

7.7 Quad Enable (QE)

The Quad Enable (QE) bit is a non-volatile read/write bit in the Status register (S9) that allows Quad operation. When the QE pin is set to a 1 (factory default), pins 3 and 7 of the device are configured as bidirectional pins IO₂ and IO₃. When the QE bit is cleared to 0, pins 3 and 7 are configured as input pins \overline{WP} and \overline{HOLD} .

WARNING: The QE bit should never be set to a 1 during standard SPI or Dual SPI operation if the \overline{WP} or \overline{HOLD} pins are tied directly to the power supply or ground.

7.8 Complement Protect (CMP)

The Complement Protect bit (CMP) is a non-volatile read/write bit (S14). It is used in conjunction with SEC, TB, BP2, BP1 and BP0 bits to provide more flexibility for the array protection. Once CMP is set to 1, previous array protection set by SEC, TB, BP2, BP1 and BP0 is reversed. For instance, when CMP = 0, a top 4 kB sector can be protected while the rest of the array is not; when CMP = 1, the top 4 kB sector becomes unprotected while the rest of the array becomes read-only. For more information, see Table 5 and Table 6 below. The default setting is CMP = 0.

7.9 Erase/Program Suspend Status (SUS)

The Suspend Status bit (SUS) is a read only bit in the status register (S15) that is set to 1 after executing an Erase/Program Suspend (75h) command. The SUS status bit is cleared to 0 by Erase/Program Resume (7Ah) command as well as a power down, power-up cycle.

Table 5. Status Register Memory Protection (CMP = 0)

Status Register Bits					Memory Protection			
SEC	TB	BP2	BP1	BP0	Sector(s)	Address Range	Density	Portion of Memory
X	X	0	0	0	NONE	NONE	NONE	NONE
0	0	0	0	1	126 and 127	7E0000h - 7FFFFFFh	128 kB	Upper 1/64
0	0	0	1	0	124 through 127	7C0000h - 7FFFFFFh	256 kB	Upper 1/32
0	0	0	1	1	120 through 127	780000h - 7FFFFFFh	512 kB	Upper 1/16
0	0	1	0	0	112 through 127	700000h - 7FFFFFFh	1 MB	Upper 1/8
0	0	1	0	1	96 through 127	600000h - 7FFFFFFh	2 MB	Upper 1/4
0	0	1	1	0	64 through 127	400000h - 7FFFFFFh	4 MB	Upper 1/2
0	1	0	0	1	0 and 1	000000h - 01FFFFh	128 kB	Lower 1/64
0	1	0	1	0	0 through 3	000000h - 03FFFFh	256 kB	Lower 1/32
0	1	0	1	1	0 through 7	000000h - 07FFFFh	512 kB	Lower 1/16
0	1	1	0	0	0 through 15	000000h - 0FFFFFFh	1 MB	Lower 1/8
0	1	1	0	1	0 through 31	000000h - 1FFFFFFh	2 MB	Lower 1/4
0	1	1	1	0	0 through 63	000000h - 3FFFFFFh	4 MB	Lower 1/2
X	X	1	1	1	0 through 127	000000h - 7FFFFFFh	8 MB	ALL
1	0	0	0	1	127	7FF000h - 7FFFFFFh	4 kB	U – 1/2048 ⁴
1	0	0	1	0	127	7FE000h - 7FFFFFFh	8 kB	U – 1/1024
1	0	0	1	1	127	7FC000h - 7FFFFFFh	16 kB	U – 1/512
1	0	1	0	X	127	7F8000h - 7FFFFFFh	32 kB	U – 1/256
1	1	0	0	1	0	000000h - 000FFFh	4 kB	L – 1/2048
1	1	0	1	0	0	000000h - 001FFFh	8 kB	L – 1/1024
1	1	0	1	1	0	000000h - 003FFFh	16 kB	L – 1/512
1	1	1	0	X	0	000000h - 007FFFh	32 kB	L – 1/256

1. X = Don't care

2. L = Lower; U = Upper

3. If any Erase or Program command specifies a memory region that contains protected data portion, this command is ignored.

4. Note 3 does not apply to this Status Register Bit setting. See Errata 1 at the end of this document for details.

Table 6. Status Register Memory Protection (CMP = 1)

Status Register Bits					Memory Protection			
SEC	TB	BP2	BP1	BP0	Sector(s)	Address Range	Density	Portion of Memory
X	X	0	0	0	0 through 127	000000h - 7FFFFFFh	8 MB	ALL
0	0	0	0	1	0 through 125	000000h - 7DFFFFFFh	8,064 kB	Lower 63/64
0	0	0	1	0	0 and 121	000000h - 7BFFFFFFh	7,936 kB	Lower 31/32
0	0	0	1	1	0 through 119	000000h - 77FFFFFFh	7,680 kB	Lower 15/16
0	0	1	0	0	0 through 111	000000h - 6FFFFFFh	7,168 kB	Lower 7/8
0	0	1	0	1	0 through 95	000000h - 5FFFFFFh	6 MB	Lower 3/4
0	0	1	1	0	0 through 63	000000h - 3FFFFFFh	4 MB	Lower 1/2
0	1	0	0	1	2 through 127	020000h - 7FFFFFFh	8,064 kB	Upper 63/64
0	1	0	1	0	4 and 127	040000h - 7FFFFFFh	7,936 kB	Upper 31/32
0	1	0	1	1	8 through 127	080000h - 7FFFFFFh	7,680 kB	Upper 15/16
0	1	1	0	0	16 through 127	100000h - 7FFFFFFh	7,168 kB	Upper 7/8
0	1	1	0	1	32 through 127	200000h - 7FFFFFFh	6 MB	Upper 3/4
0	1	1	1	0	64 through 127	400000h - 7FFFFFFh	4 MB	Upper 1/2
X	X	1	1	1	NONE	NONE	NONE	NONE
1	0	0	0	1	0 through 127	000000h - 7FEFFFFh	8,188 kB	L – 2047/2048
1	0	0	1	0	0 through 127	000000h - 7FDFFFFh	8,184 kB	L – 1023/1024
1	0	0	1	1	0 through 127	000000h - 7FBFFFFh	8,176 kB	L – 511/512
1	0	1	0	X	0 through 127	000000h - 7F7FFFFh	8,160 kB	L – 255/256
1	1	0	0	1	0 through 127	001000h - 7FFFFFFh	8,188 kB	U – 2047/2048 ⁴
1	1	0	1	0	0 through 127	002000h - 7FFFFFFh	8,184 kB	U – 1023/1024
1	1	0	1	1	0 through 127	004000h - 7FFFFFFh	8,176 kB	U – 511/512
1	1	1	0	X	0 through 127	008000h - 7FFFFFFh	8,160 kB	U – 255/256

1. X = don't care

2. L = Lower; U = Upper

3. If any Erase or Program command specifies a memory region that contains protected data portion, this command is ignored.

4. Note 3 does not apply to this Status Register Bit setting. See Errata 2 at the end of this document for details.

8. Commands

The SPI command set of the AT25QL641 consists of thirty eight basic commands and the QPI command set of the AT25QL641 consists of thirty one basic commands that are fully controlled through the SPI bus (see [Table 8](#) through [Table 11](#)). Commands are initiated with the falling edge of Chip Select (\overline{CS}). The first byte of data clocked into the input pins (SI or I/O [3:0]) provides the command code. Data on the SI input is sampled on the rising edge of clock with most significant bit (MSB) first.

Commands are completed with the rising edge of edge \overline{CS} . All read commands can be completed after any clocked bit. However, all commands that Write, Program or Erase must complete on a byte (\overline{CS} driven high after the full 8 bits has been clocked) otherwise the command is terminated. This feature further protects the device from inadvertent writes. Additionally, while the memory is being programmed or erased, or when the Status Register is being written, all commands except for Read Register are ignored until the program or erase cycle has completed.

Table 7. Manufacturer and Device Identification

		ID code	Command
Manufacturer ID	Renesas Electronics	1Fh	90h, 92h, 94h, 9Fh
Device ID	AT25QL641	16h	90h, 92h, 94h, ABh
Memory Type ID	SPI / QPI	43h	9Fh
Capacity Type ID	64M	17h	9Fh

8.1 Command Tables

Table 8. Command Set Table 1 (SPI Commands) [1]

Command Byte	0	1	2	3	4	5
Clock Number	0 - 7	8 - 15	16 - 23	24 - 31	32 - 39	40 - 47
Write Enable	06h					
Write Enable (for volatile Status registers)	50h					
Write Disable	04h					
Read Status Register 1	05h	SR7:SR0 ^[2]				
Read Status Register 2	35h	SR15:SR8 ⁽²⁾				
Write Status Register 1	01h	SR7:SR0	SR15:SR8			
Write Status Register 2	31h	SR15:SR8				
Read Data	03h	A23:A16	A15:A8	A7:A0	D7:D0	
Fast Read Data	0Bh	A23:A16	A15:A8	A7:A0	Dummy	D7:D0
Page Program	02h	A23:A16	A15:A8	A7:A0	D7:D0 ^[3]	
Enable QPI	38h					
Block Erase (4 kB)	20h	A23:A16	A15:A8	A7:A0		
Block Erase (32 kB)	52h	A23:A16	A15:A8	A7:A0		
Block Erase (64 kB)	D8h	A23:A16	A15:A8	A7:A0		
Chip Erase	60h/7Ch					
Erase/Program Suspend	75h					
Erase/Program Resume	7Ah					
Deep Power-Down	B9h					
Release from Deep Power-Down/Device ID	ABh	Dummy	Dummy	Dummy	D7:D0 ⁽²⁾	
Read Manufacturer ID ^[4]	90h	00h	00h	00h or 01h	MID7:MID0	DID7:DID0
Read JEDEC ID	9Fh	MID7:MID0	D7:D0	D7:D0		
Reset Enable	66h					
Reset	99h					
Enter Secured OTP	B1h					
Exit Secured OTP	C1h					
Read Security Register	2Bh	SC7:SC0 ^[5]				
Write Security Register	2Fh					
Read Serial Flash Discovery Parameters	5Ah	A23:A16	A15:A8	A7:A0	Dummy	D7:D0

1. Data bytes are shifted with Most Significant Bit first. Byte fields with data in parenthesis () indicate data being read from the device on the I/O pin.
2. SR = status register, The Status Register contents and Device ID repeats continuously until CS terminates the command.
3. At least one byte of data input is required for Page Program, Quad Page Program and Program Security Register, up to 256 bytes of data input. If more than 256 bytes of data are sent to the device, the addressing wraps to the beginning of the page and overwrites previously sent data.
4. See Table 7 for Device ID information.
5. SC = security register.

Table 9. Command Set Table 2 (Dual SPI Commands)

Command Byte	0	1	2	3	4	5
Clock Number	0 - 7	8 - 15	16 - 23	24 - 31	32 - 39	40 - 47
Fast Read Dual Output	3Bh	A23:A16	A15:A8	A7:A0	Dummy	D7:D0 ^[1]
Fast Read Dual I/O	BBh	A23:A8 ^[2]	A7:A0, M7:M0 ⁽²⁾	D7:D0.... ⁽¹⁾		
Read Manufacturer ID ^[3]	92h	0000h	(00h, xxxx) or 01h, xxxx)	MID7:MID0 DID7:DID0 ⁽¹⁾		

- Dual Output data: I/O₀ = (D6, D4, D2, D0), I/O₁ = (D7, D5, D3, D1)
- Dual input address:
I/O₀ = A22, A20, A18, A16, A14, A12, A10, A8, A6, A4, A2, A0, M6, M4, M2, M0
I/O₁ = A23, A21, A19, A17, A15, A13, A11, A9, A7, A5, A3, A1, M7, M5, M3, M1
- See Table 7 for Device ID information.

Table 10. Command Set Table 3 (Quad SPI Commands)

Command Byte	0	1	2	3	4	5
Clock Number	0 - 7	8 - 15	16 - 23	24 - 31	32 - 39	40 - 47
Fast Read Quad Output	6Bh	A23:A16	A15:A8	A7:A0	Dummy	D7:D0 ^[1]
Fast Read Quad I/O	EBh	A23:A0, M7:M0 ^[2]	(xxxx, D7:D0...) ^[3]	D7:D0.... ⁽¹⁾		
Quad Page Program	33h	A23:A0 (D7:D0, ...) ¹				
Read Quad Manufacturer ID ^[4]	94h	00_0000h, xx or 00_00001h, xx	(xxxx, MID7:MID0) (xxxx, DID7:DID0) ⁽³⁾			
Fast Read Quad I/O	EBh	A23:A0 M7:M0 ²	(xx, D7:D0)	D7:D0 ¹		
Set Burst with Wrap	77h	xxxxxx, W6:W4 ^[5]				

- Quad Input/ Output Data
I/O₀ = (D4, D0...)
I/O₁ = (D5, D1...)
I/O₂ = (D6, D2...)
I/O₃ = (D7, D3...)
- Quad Input Address
I/O₀ = A20, A16, A12, A8, A0, M4, M0
I/O₁ = A21, A17, A13, A9, A1, M5, M1
I/O₂ = A22, A18, A14, A10, A2, M6, M2
I/O₃ = A23, A19, A15, A11, A3, M7, M3
- Fast Read Quad I/O Data Output
I/O₀ = (x, x, x, x, D4, D0...)
I/O₁ = (x, x, x, x, D5, D1...)
I/O₂ = (x, x, x, x, D6, D2...)
I/O₃ = (x, x, x, x, D7, D3...)
- See Table 7 for Device ID information.
- Set Burst With Wrap
I/O₀ = x, x, x, x, x, x, W4, x
I/O₁ = x, x, x, x, x, x, W5, x
I/O₂ = x, x, x, x, x, x, W6, x
I/O₃ = x, x, x, x, x, x, W7, x

Table 11. Command Set Table 4 (QPI Commands)

Command Byte ^[1]	0	1	2	3	4	5	6	7	8	
Clock Number	0, 1	2, 3	4, 5	6, 7	8, 9	10, 11	12, 13	14, 15	16, 17	
Write Enable	06h									
Write Enable (for volatile Status registers)	50h									
Write Disable	04h									
Read Status Register 1	05h	(SR7:SR0) [2]								
Read Status Register 2	35h	(SR15:SR8)) (2)								
Write Status Register 1 ⁽²⁾	01h	(SR7:SR0)	(SR15:SR8))							
Write Status Register 2	31h	(SR15:SR8))								
Set Read Parameters	C0h	P7:P0								
Fast Read Data	up to 80 MHz	0Bh	A23:A16	A15:A8	A7:A0	Dummy	Dummy	(D7:D0)		
	up to 104 MHz		A23:A16	A15:A8	A7:A0	Dummy	Dummy	Dummy	(D7:D0))	
	up to 133 MHz		A23:A16	A15:A8	A7:A0	Dummy	Dummy	Dummy	Dummy	(D7:D0))
Page Program	02h	A23:A16	A15:A8	A7:A0	(D7:D0) [3]					
Block Erase (4 kB)	20h	A23:A16	A15:A8	A7:A0						
Block Erase (32 kB)	52h	A23:A16	A15:A8	A7:A0						
Block Erase (64 kB)	D8h	A23:A16	A15:A8	A7:A0						
Chip Erase	60h/7Ch									
Erase/Program Suspend	75h									
Erase/Program Resume	7Ah									
Deep Power-Down	B9h									
Release from Deep Power-Down	ABh									
Read Manufacturer/ Device ID ^[4]	90h	00h	00h	00h or 01h	(MID7: MID0)	(DID7: DID0)				
Read JEDEC ID	9Fh	(MID7:MID0) (Mfg ID)	(D7:D0) (Mem Typ)	(D7:D0) (Cap)						
Enter Secured OTP	B1h									
Exit Secured OTP	C1h									
Read Security Register	2Bh	(SC7:SC0) [5]								
Write Security Register	2Fh									

Table 11. Command Set Table 4 (QPI Commands) (Continued)

Command Byte ^[1]	0	1	2	3	4	5	6	7	8
Clock Number	0, 1	2, 3	4, 5	6, 7	8, 9	10, 11	12, 13	14, 15	16, 17
Fast Read Quad I/O ^[6]	EBh	up to 80 MHz	A23:A16	A15:A8	A7:A0	(M7:M0)	Dummy	(D7:D0)	
		up to 104 MHz	A23:A16	A15:A8	A7:A0	(M7:M0)	Dummy	Dummy	(D7:D0)
		up to 133 MHz	A23:A16	A15:A8	A7:A0	(M7:M0)	Dummy	Dummy	Dummy
Reset Enable	66h								
Reset	99h								
Disable QPI	FFh								
Burst Read with Wrap	0Ch	up to 80 MHz	A23:A16	A15:A8	A7:A0	Dummy	Dummy	(D7:D0)	
		up to 104 MHz	A23:A16	A15:A8	A7:A0	Dummy	Dummy	Dummy	(D7:D0)
		up to 133 MHz	A23:A16	A15:A8	A7:A0	Dummy	Dummy	Dummy	Dummy
Quad Page Program	33h	A23:A16	A15:A8	A7:A0	(D7:D0)				

1. Data bytes are shifted with Most Significant Bit first. Byte fields with data in parenthesis () indicate data being read from the device on the I/O pin.
2. SR = Status Register. The Status Register contents and Device ID repeat continuously until \overline{CS} terminates the command.
3. At least one byte of data input is required for Page Program, Quad Page Program and Program Security Register, up to 256 bytes of data input. If more than 256 bytes of data are sent to the device, the address wraps to the beginning of the page and overwrite previously sent data.
4. See Table 7 for Device ID information.
5. SC = Security Register.
6. The M7-M0 bits are counted as dummy clocks.

8.2 Write Enable (06h)

The Write Enable command is used for setting the Write Enable Latch (WEL) bit in the Status Register. The WEL bit must be set prior to every Program, Erase and Write Status Register command. To execute the Write Enable command, drive \overline{CS} low prior to driving command 06h onto the SI pin on the rising edge of SCK, and then driving \overline{CS} high.

Figure 5. Write Enable Command for SPI Mode (left) and QPI Mode (right)

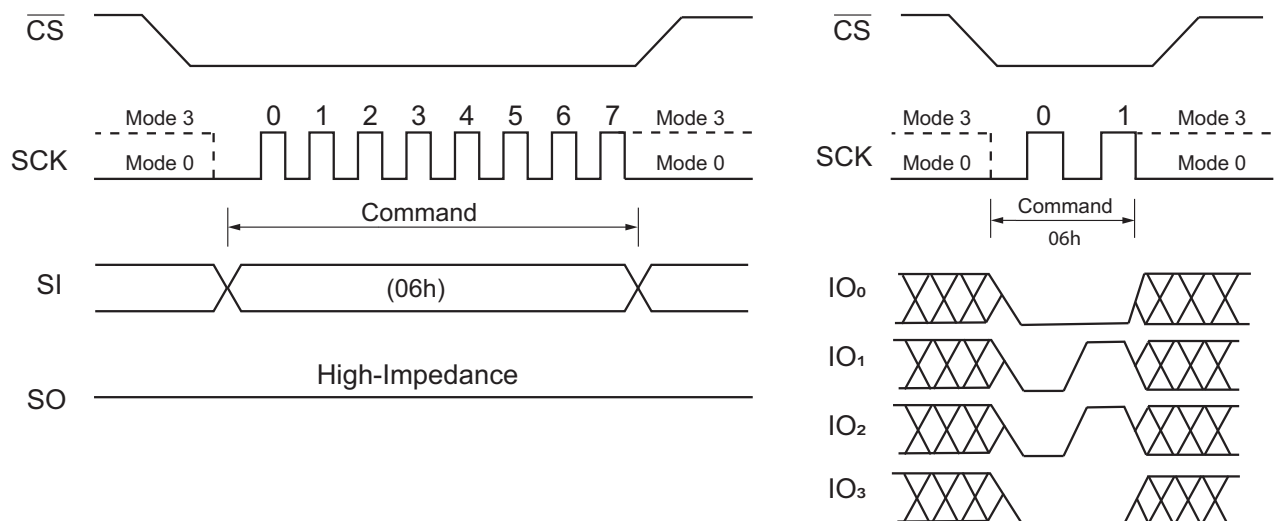

8.3 Write Enable for Volatile Status Register (50h)

This command gives more flexibility to change the system configuration and memory protection schemes quickly without waiting for the typical non-volatile bit write cycles or affecting the endurance of the Status Register non-volatile bits. To write the volatile values into the Status Register bits, the Write Enable for Volatile Status Register (50h) command must be issued prior to a Write Status Register (01h) command. The Write Enable for Volatile Status Register command does not set the Write Enable Latch (WEL) bit.

When Write Enable for Volatile Status Register command (50h) is executed in QPI Mode, the SUS bit (S15) and Reserved bits (S13, S12, S11 and S10) of Status Register-2 must be driven high after Write Status Register command (01h). Once the Read Status Register (05h or 35h) is issued, the read values of the SUS bit (S15) and Reserved bits (S13, S12, S11 and S10) of the Status Register-2 are ignored.

Figure 6. Write Enable for Volatile Status Register Command for SPI Mode (left) and QPI Mode (right)

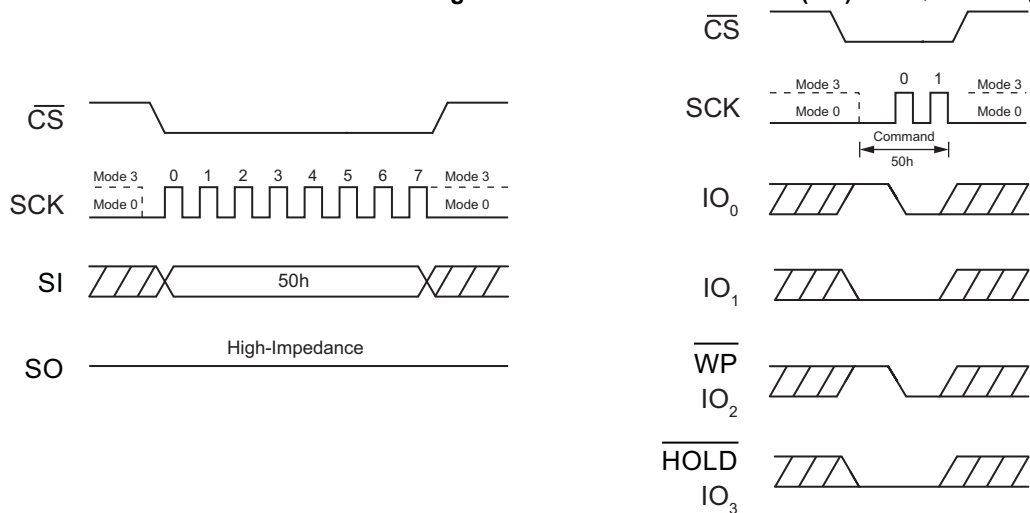

8.4 Write Disable (04h)

The Write Disable command is used to reset the Write Enable Latch (WEL) bit in the Status Register. To enter the Write Disable command, \overline{CS} goes low prior to the command 04h into Data Input (SI) pin on the rising edge of SCK, and then driving \overline{CS} high. The WEL bit is automatically reset upon completion of the every Program, Erase and Write Status Register commands.

Figure 7. Write Disable Command for SPI Mode (left) and QPI Mode (right)

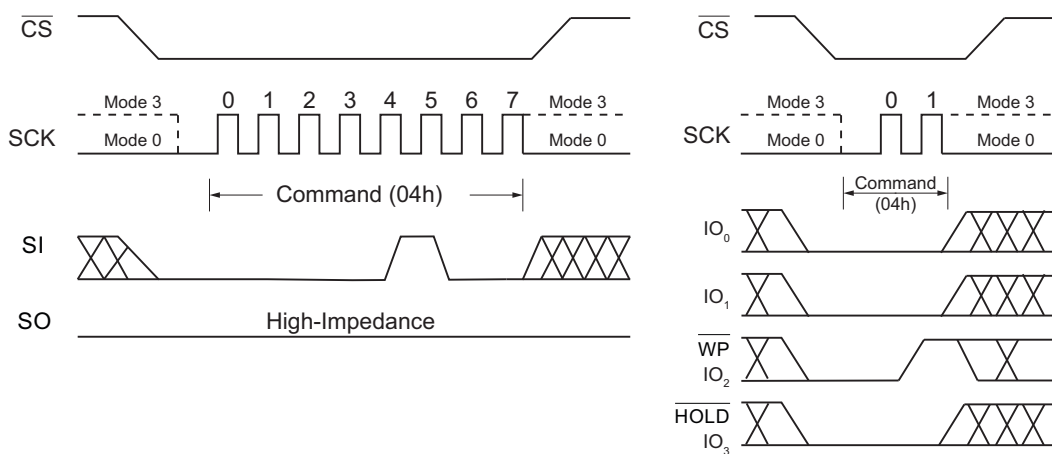

8.5 Read Status Register-1 (05h) and Read Status Register-2 (35h)

The Read Status Register commands are used to read the Status register. They can be executed at any time (even in the Program/Erase/Write Status Register and Write Security Register conditions). It is recommended to check the BUSY bit before sending a new command when a Program, Erase, Write Status Register or Write Status Register operation is in progress.

The command is entered by driving \overline{CS} low and sending the command code 05h for Status Register-1 or 35h for Status Register-2 into the SI pin on the rising edge of SCK. The status register bits are then shifted out on the SO pin at the falling edge of SCK with most significant bit (MSB) first as shown in (Figure 8 and Figure 9). The Status Register can be read continuously. The command is completed by driving \overline{CS} high.

Figure 8. Read Status Register Command (SPI Mode)

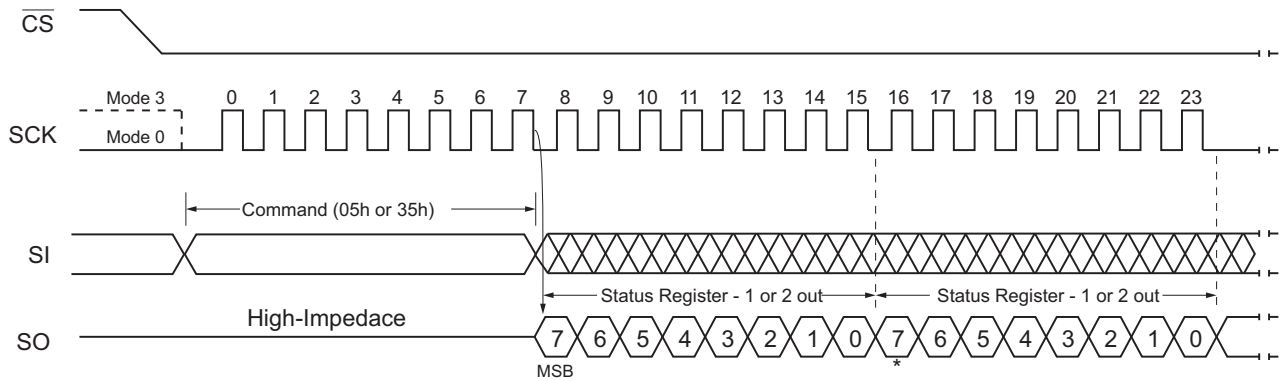
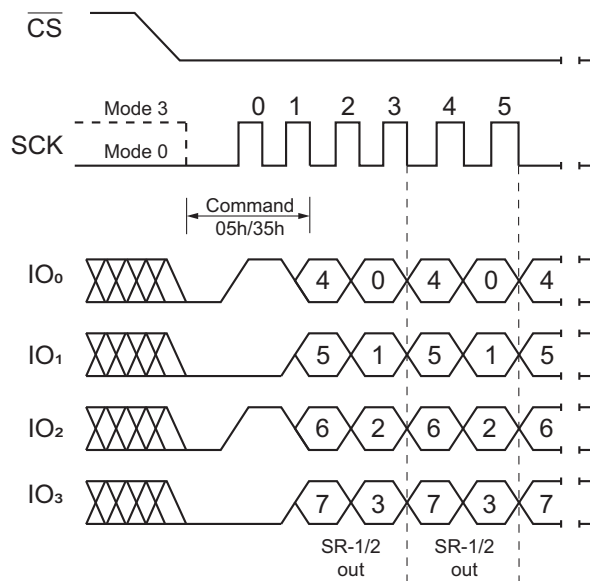

Figure 9. Read Status Register Command (QPI Mode)



8.6 Write Status Register (01h)

The Write Status Register command is used to write only the non-volatile Status Register-1 bit SRP0, and Status Register-2 bits QE and SRP1. All other Status Register bit locations are read-only and are not affected by the Write Status Register command.

A Write Enable (06h) command must previously have been issued prior to setting Write Status Register Command (Status Register bit WEL must equal 1). Once the WEL bit is set, the command is entered by driving \overline{CS} low, sending the command code, and then writing the status register data byte as illustrated in Figure 10 and Figure 11.

The \overline{CS} pin must be driven high after the eighth or sixteenth bit of data that is clocked in. If this is not done, the Write Status Register command is not executed. If \overline{CS} is driven high after the eighth clock, the CMP, QE and SRP1 (Status Register 2) bits are cleared to 0. After \overline{CS} is driven high, the self-timed Write Status Register cycle commences for a time duration of t_w (see Table 26, AC Electrical Characteristics).

While the Write Status Register cycle is in progress, the Read Status Register command may still be accessed to check the status of the BUSY bit. The BUSY bit is a 1 during the Write Status Register cycle and a 0 when the cycle is finished and ready to accept other commands again. When the BUSY bit is asserted, the Write Enable Latch (WEL) bit in Status Register is cleared to 0.

Figure 10. Write Status Register Command (SPI Mode)

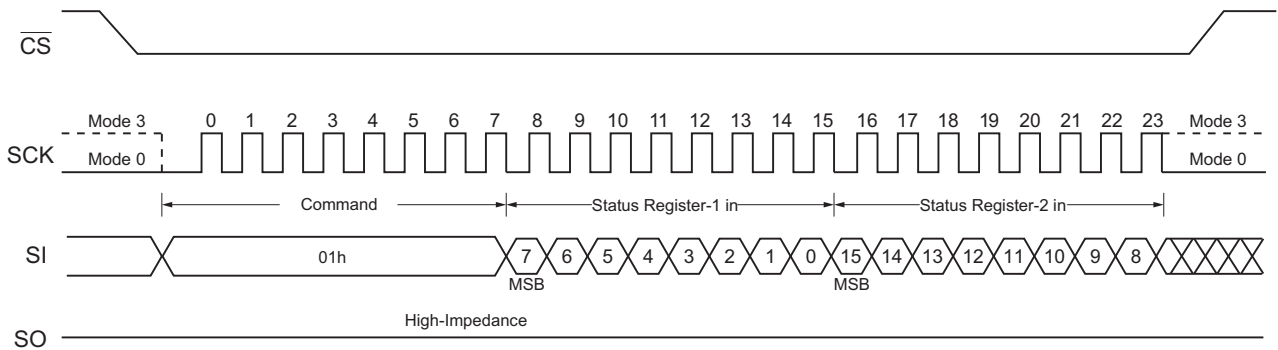
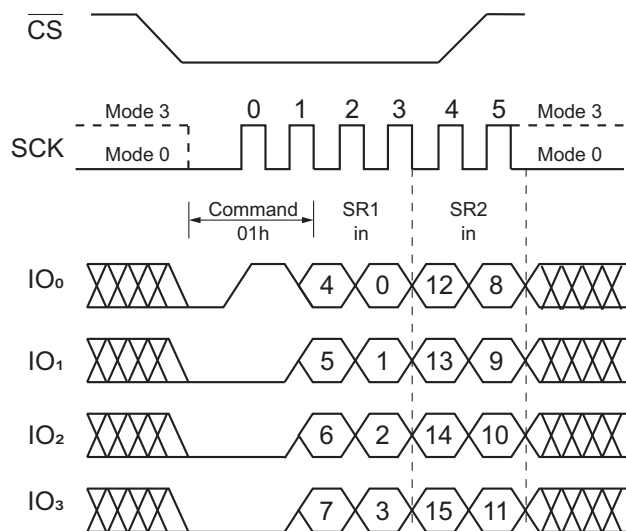

Figure 11. Write Status Register Command (QPI Mode)



8.7 Write Status Register-2 (31h)

The Write Status Register-2 command is used to write only non-volatile Status Register-2 bits CMP, QE and SRP1.

A Write Enable (06h) command must have previously been issued prior to executing the Write Status Register Command (Status Register bit WEL must equal 1). Once the WEL bit is set, the command is entered by driving CS low, sending the command code, and then writing the status register data byte as illustrated in Figure 12 and Figure 13.

Using the Write Status Register-2 (31h) command, software can individually access each one-byte Status register via a different command.

Figure 12. Write Status Register-2 Command (SPI Mode)

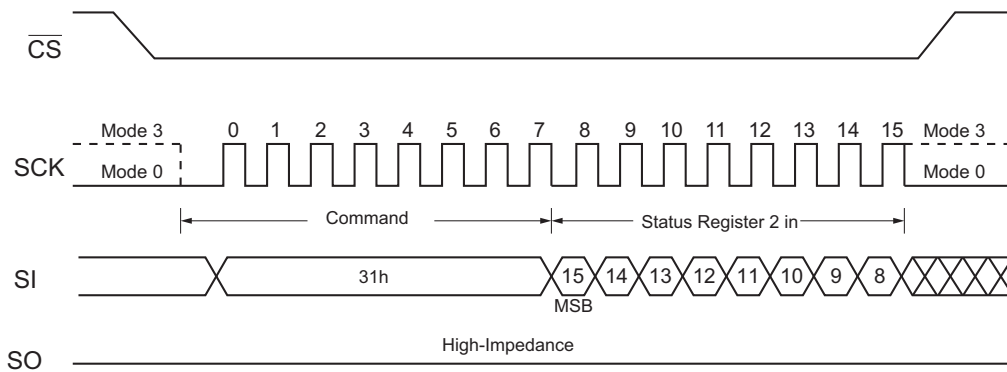
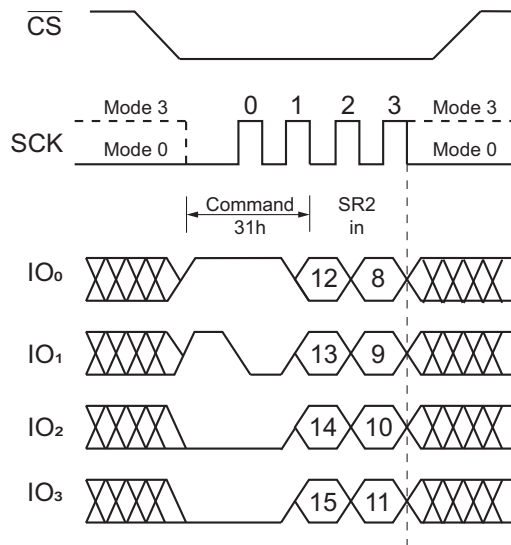

Figure 13. Write Status Register-2 Command (QPI Mode)



8.8 Set Read Parameters (C0h)

In QPI mode, to accommodate a wide range of applications with different needs for either maximum read frequency or minimum data access latency, the Set Read Parameters (C0h) command can be used to configure the number of dummy clocks for Fast Read (0Bh), Fast Read Quad I/O (EBh) and Burst Read with Wrap (0Ch) commands, and to configure the number of bytes of Wrap Length for the Burst Read with Wrap (0Ch) command.

In Standard SPI mode, the Set Read Parameters (C0h) command is not accepted. The dummy clocks for various Fast Read commands in Standard/Dual/Quad SPI mode are fixed (see the command). The Wrap Length is set by W6-5 bit in the Set Burst with Wrap (77h) command. This setting remains unchanged when the device is switched from Standard SPI mode to QPI mode.

The default Wrap Length after a power up or a Reset command is 8 bytes, the default number of dummy clocks is 4.

When the Set Read Parameters command is executed, an 8-bit value (P7-P0) is transferred to the memory. Within this 8-bit value, bits P5-P4 are used to set the number of dummy clocks and the maximum read frequency as shown in Table 12. The P1-P0 bits are used to set the wrap length as shown in Table 13. All other bits are unused.

Table 12. Encoding of P[5:4] Bits

P5, P4	Dummy Clocks	Maximum Read Frequency
00	4	80 MHz
01	4	80 MHz
10	6	104 MHz
11	8	133 MHz

Table 13. Encoding of P[1:0] Bits

P1, P0	Wrap Length
0 0	8-byte
0 1	16-byte
1 0	32-byte
1 1	64-byte

Figure 14. Set Read Parameters Command (QPI Mode)

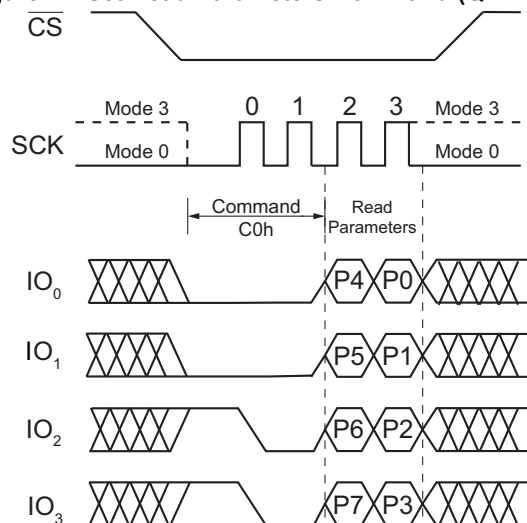

8.9 Read Data (03h)

The Read Data command is used to read data out from the device. The command is initiated by driving the \overline{CS} pin low and then sending the command code 03h followed by a 24-bit address (A23 - A0) onto the SI pin. After the address is received, the data byte of the addressed memory location is shifted out on the SO pin at the falling edge of SCK with the most significant bit (MSB) first. The address is automatically incremented to the next higher address after byte of data is shifted out allowing for a continuous stream of data. This means that the entire memory can be accessed with a single command as long as the clock continues. The command is completed by driving \overline{CS} high.

The Read Data command sequence is shown in Figure 15. If a Read Data command is issued while an Erase, Program or Write Status Register cycle is in process (BUSY = 1) the command is ignored and does not have any effects on the current cycle. The Read Data command allows clock rates from D.C to a maximum of f_R (see Table 26, AC Electrical Characteristics).

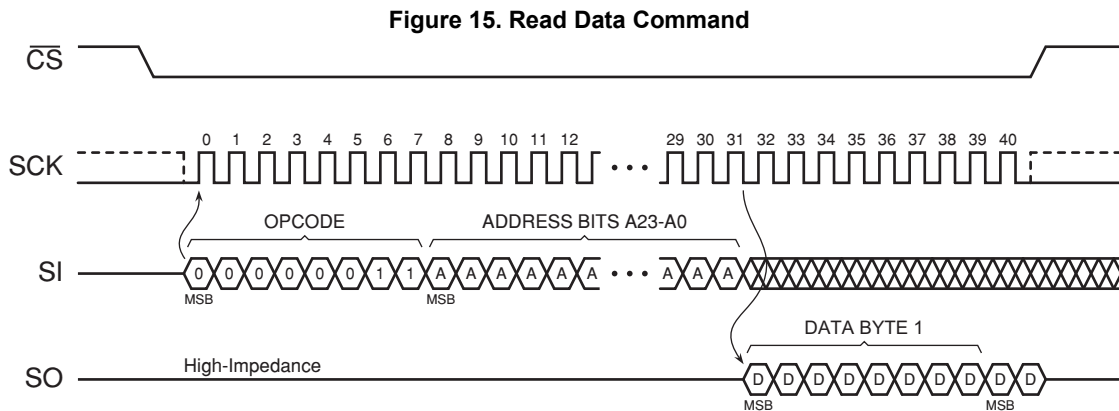

8.10 Fast Read (0Bh)

The Fast Read command is high-speed reading mode that it can operate at the highest possible frequency of FR. The address is latched on the rising edge of the SCK. After the 24-bit address, this is accomplished by adding dummy clocks as shown in Figure 16. The dummy clocks means the internal circuits require time to set up the initial address. During the dummy clocks, the data value on the SO pin is a don't care. Data of each bit shifts out on the falling edge of SCK.

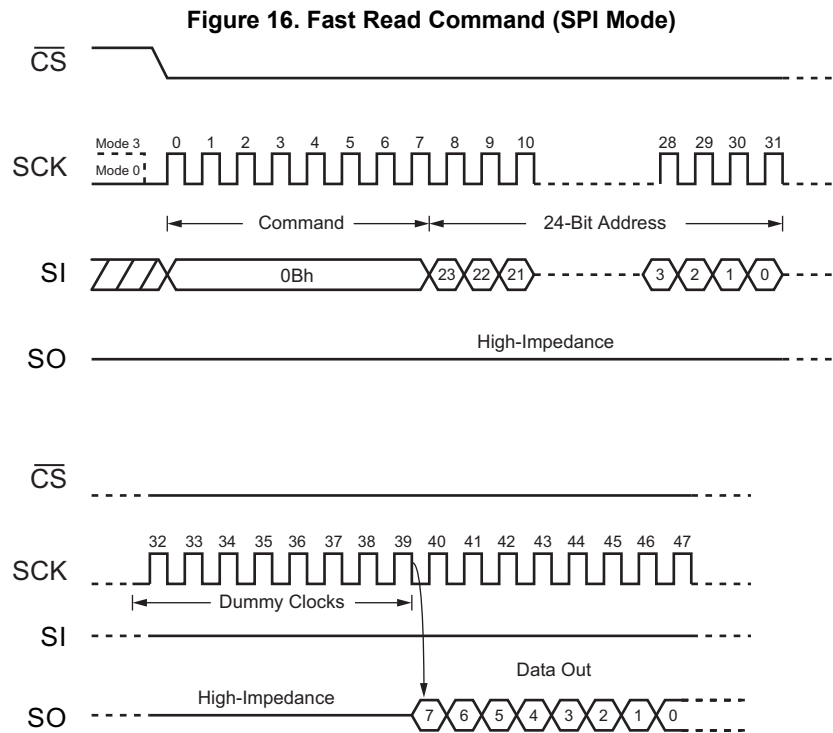

Fast Read in QPI Mode

When QPI mode is enabled, the number of dummy clock is configured by the Set Read Parameters (C0h) command to accommodate wide range applications with different needs for either maximum Fast Read frequency or minimum data access latency. The number of dummy clock cycles can be configured as either 4, 6 or 8 by setting bits P[5:4] in the 8-bit parameter of the Set Read Parameters (C0h) command as shown in Table 12, Encoding of P[5:4] Bits. The default number of dummy clocks upon power up or after a Reset command is 4. See Figure 17.

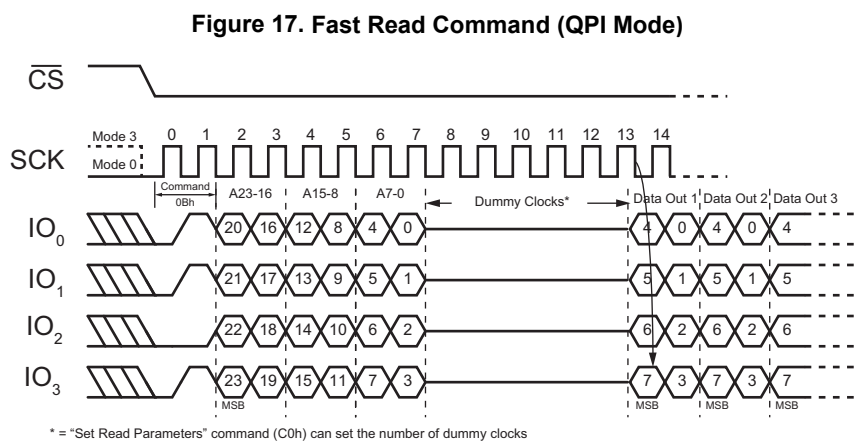

8.11 Fast Read Dual Output (3Bh)

By using two pins (I/O_0 and I/O_1 , instead of just I/O_0), The Fast Read Dual Output command allows data to be transferred from the AT25QL641 at twice the rate of standard SPI devices. The Fast Read Dual Output command is ideal for quickly downloading code from Flash to RAM upon power-up or for application that cache code-segments to RAM for execution.

The Fast Read Dual Output command can operate at the highest possible frequency of F_R (see [Table 26, AC Electrical Characteristics](#)). After the 24-bit address, this is accomplished by adding eight dummy clocks as shown in [Figure 18](#). The dummy clocks allow the internal circuits additional time for setting up the initial address. During the dummy clocks, the data value on the SO pin is a don't care. However, the I/O_0 pin should be high-impedance prior to the falling edge of the first data out clock.

Figure 18. Fast Read Dual Output Command (SPI Mode)

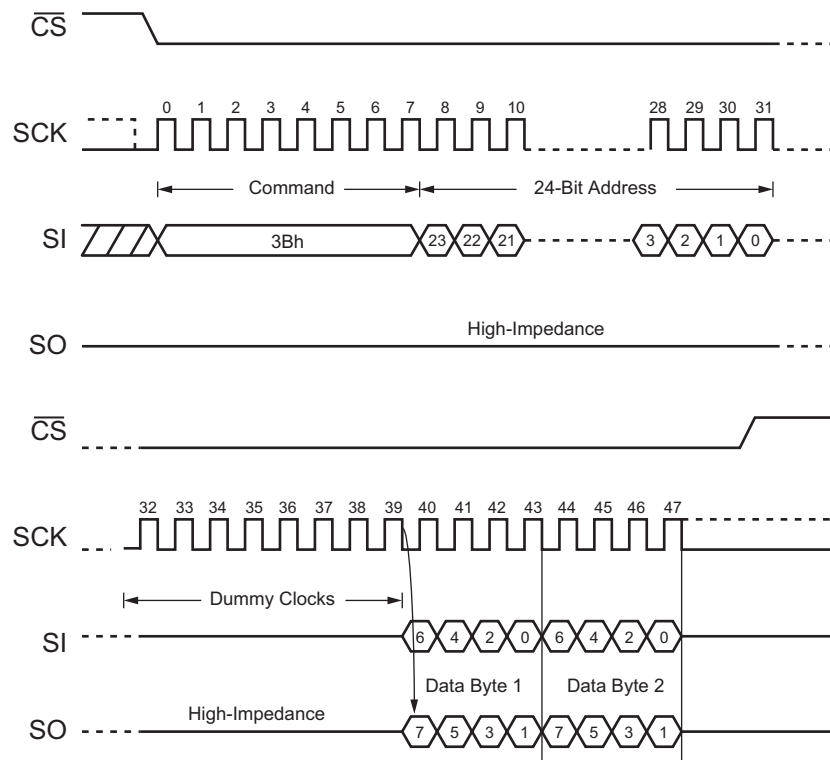

8.12 Fast Read Quad Output (6Bh)

By using four pins (I/O₀, I/O₁, I/O₂, and I/O₃), the Fast Read Quad Output command allows data to be transferred from the AT25QL641 at four times the rate of standard SPI devices. A Quad enable of Status Register-2 must be executed before the device accepts the Fast Read Quad Output command (Status register bit QE must equal 1).

The Fast Read Quad Output command can operate at the highest possible frequency of F_R (see Table 26, AC Electrical Characteristics). This is accomplished by adding eight dummy clocks after the 24-bit address as shown in Figure 19. The dummy clocks allow the internal circuits additional time for setting up the initial address. During the dummy clocks, the data value on the SO pin is a don't care. However, the I/O₀ pin should be high-impedance prior to the falling edge of the first data out clock.

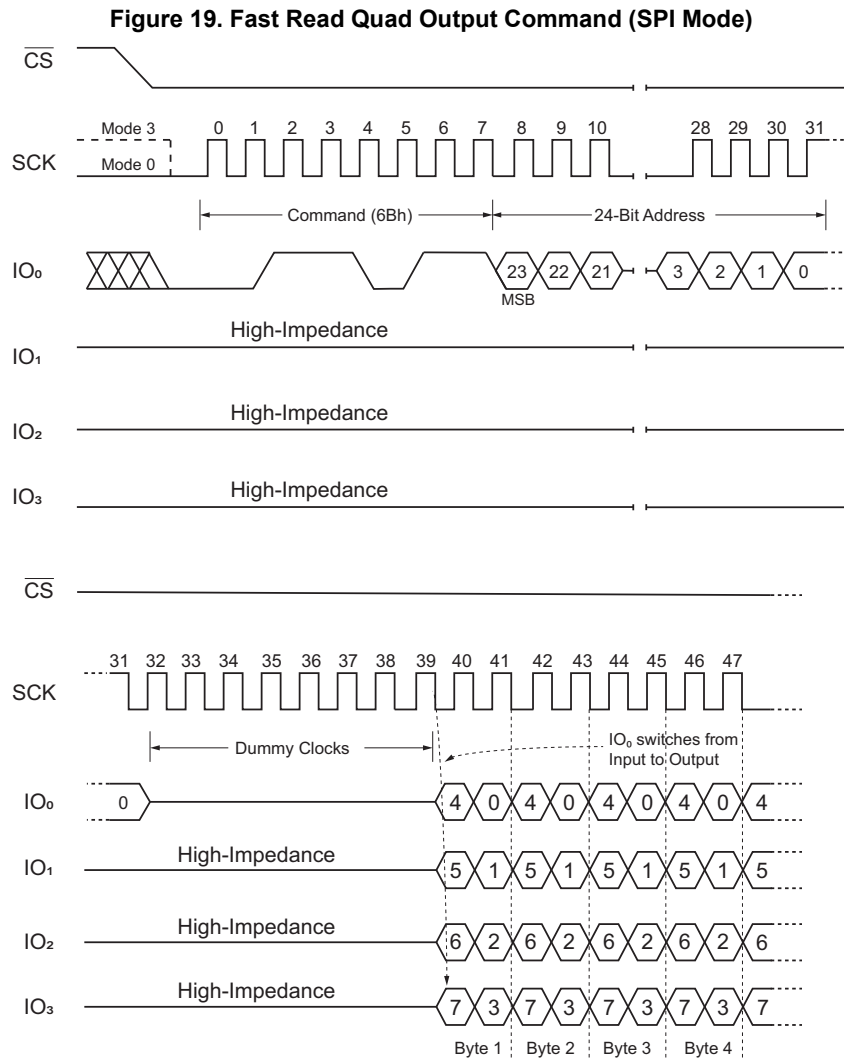

8.13 Fast Read Dual I/O (BBh)

The Fast Read Dual I/O command reduces cycle overhead through double access using two I/O pins: I/O₀ and I/O₁.

Continuous Read Mode

The Fast Read Dual I/O command can further reduce cycle overhead through setting the Mode bits (M7-0) after the input Address bits (A23-0). The upper nibble of the Mode (M7-4) controls the length of the next Fast Read Dual I/O command through the inclusion or exclusion of the first byte command code. The lower nibble bits of the Mode (M3-0) are don't care (X), However, the I/O pins should be high-impedance prior to the falling edge of the first data out clock.

If the Mode bits (M7-0) equal Ax hex, then the next Fast Dual I/O command (after \overline{CS} is raised and then lowered) does not require the command (BBh) code, as shown in Figure 20 and Figure 21. This reduces the command sequence by eight clocks and allows the address to be immediately entered after \overline{CS} is asserted low. If Mode bits (M7-0) are any value other Ax hex, the next command (after \overline{CS} is raised and then lowered) requires the first byte command code, thus returning to normal operation. A mode bit reset can be used to reset the mode bits (M7-0) before issuing normal commands.

Figure 20. Fast Read Dual I/O Command (initial command or previous M7-0 ≠ Axh)

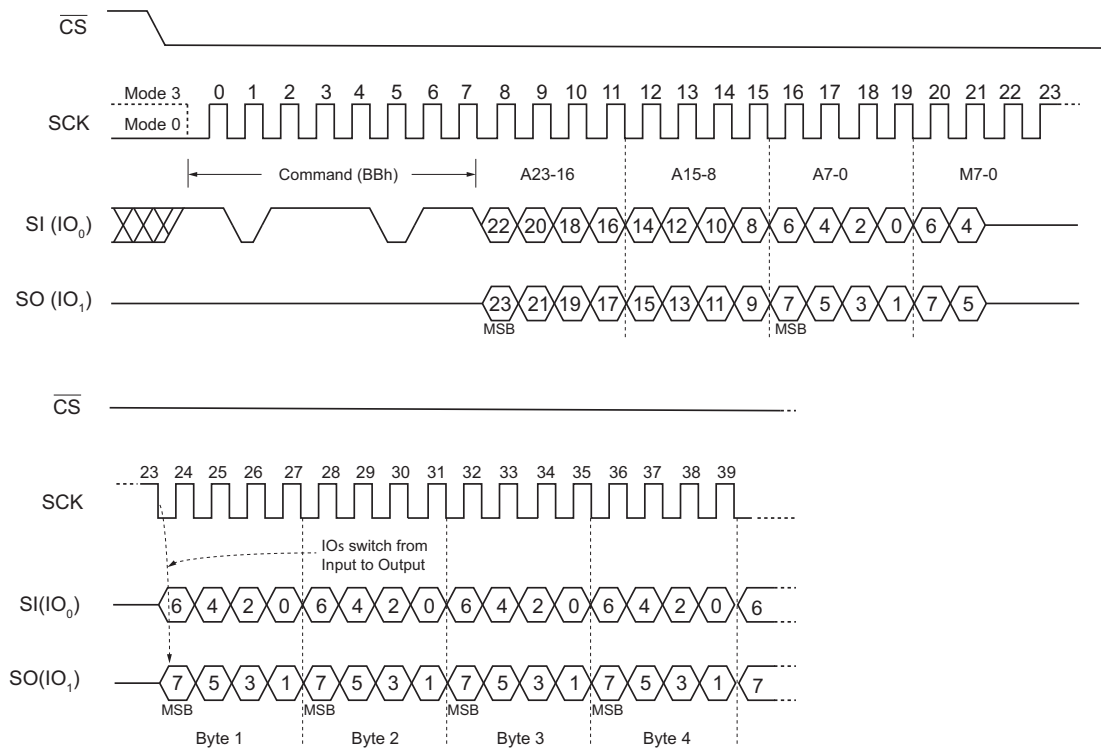
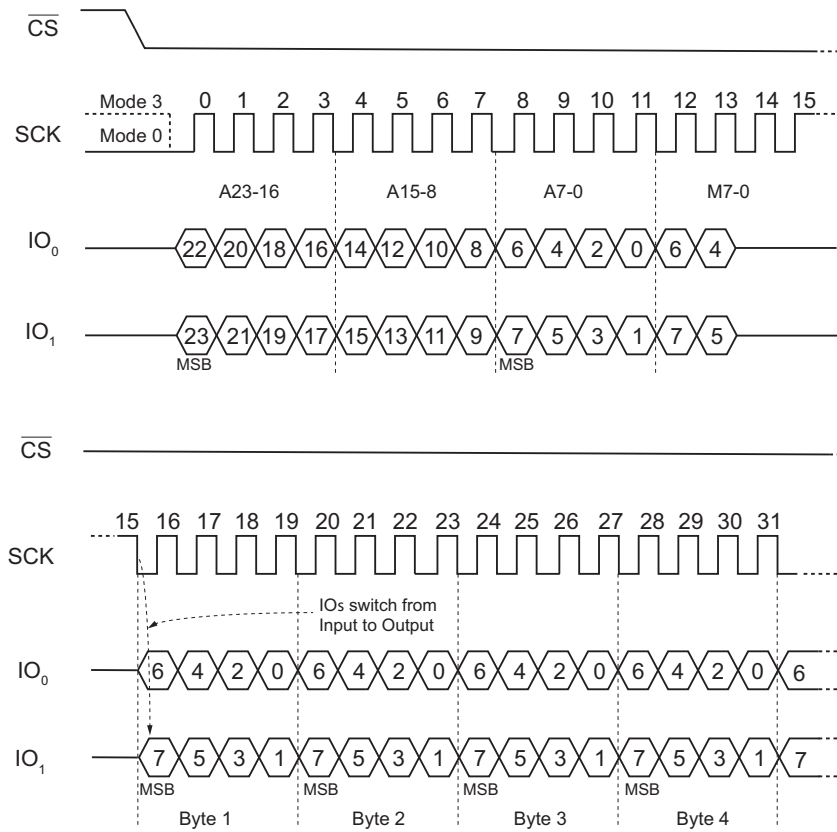

Figure 21. Fast Read Dual I/O Command (previous M7-0= Axh)



8.14 Fast Read Quad I/O (EBh)

The Fast Read Quad I/O command reduces cycle overhead through quad access using four I/O pins: I/O₀, I/O₁, I/O₂, and I/O₃. The Quad Enable bit (QE) of Status Register-2 must be set to enable the Fast read Quad I/O Command.

Continuous Read Mode

The Fast Read Quad I/O command can further reduce command overhead through setting the Mode bits (M7-0) with following the input address bits (A23-0), as shown in Figure 22. The upper nibble of the mode (M7-4) controls the length of the next Fast Read Quad I/O command through the inclusion or exclusion of the first byte command code. The lower nibble bits of the Mode (M3-0) are don't care (X). However, the I/O pins should be high-impedance prior to the falling edge of the first data out clock. Note that the mode bits are counted as dummy clocks.

If the Mode bits (M7-0) equal Ax hex, then the next Fast Read Quad I/O command (after \overline{CS} is raised and then lowered) does not require the EBh command code, as shown in Figure 23. This reduces the command sequence by eight clocks and allows the address to be immediately entered after \overline{CS} is asserted low. If the Mode bits (M7-0) are any value other than Ax hex, the next command (after \overline{CS} is raised and then lowered) requires the first byte command code, thus retuning normal operation. A Mode Bit Reset can be used to reset Mode Bits (M7-0) before issuing normal commands.

Figure 22. Fast Read Quad I/O Command (Initial command or previous M7-0 ≠ Axh, SPI mode)

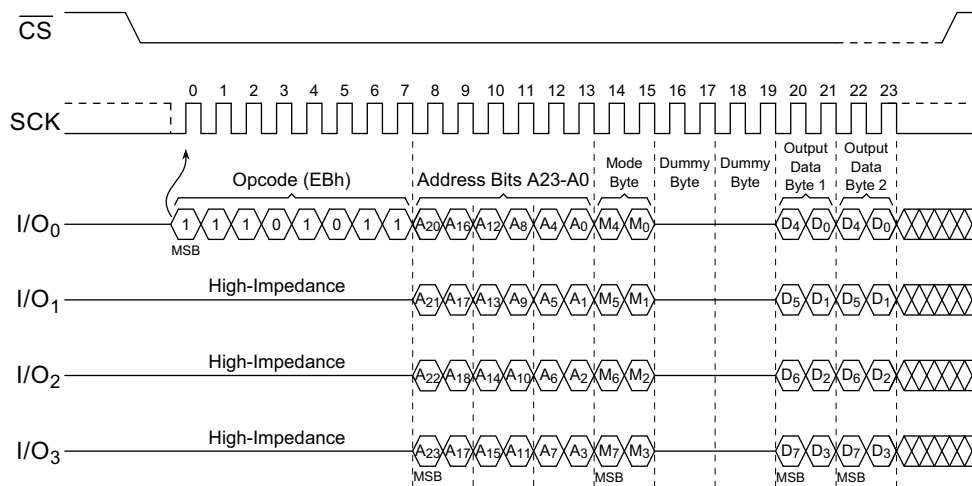
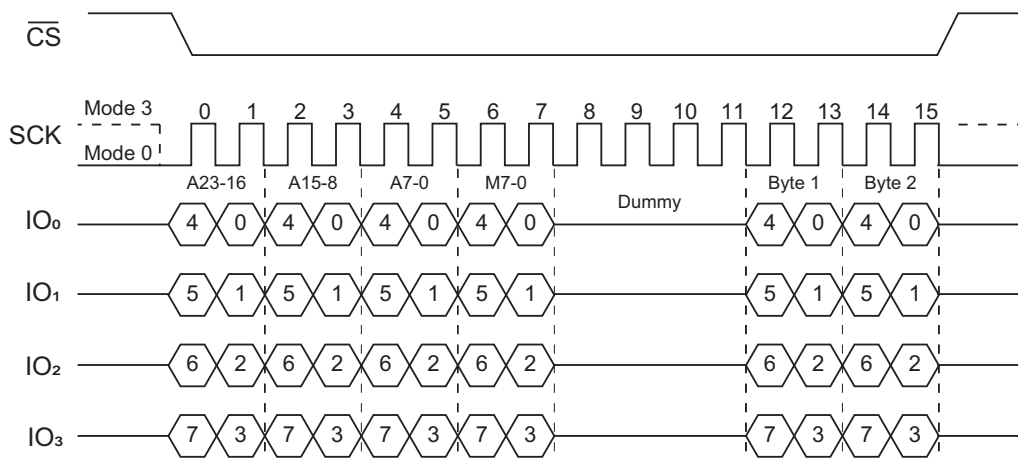

Figure 23. Fast Read Quad I/O Command (previous M7-0 = Axh, SPI mode)



Wrap Around in SPI mode

The Fast Read Quad I/O command can also be used to access specific portion within a page by issuing a Set Burst with Wrap (77h) command prior to a Fast Read Quad I/O (EBh) command. The Set Burst with Wrap (77h) command can either enable or disable the Wrap Around feature for the following Fast Read Quad I/O command.

When Wrap Around is enabled, the data being accessed can be limited to an 8/16/32/64-byte section of a 256-byte page. The output data starts at the initial address specified in the command, once it reaches the ending boundary of the 8/16/32/64-byte section, the output wraps around to the beginning boundary automatically until \overline{CS} is pulled high to terminate the command.

The Burst with Wrap feature allows applications that use cache to quickly fetch a critical address and then fill the cache afterwards within a fixed length (8/16/32/64 bytes) of data without issuing multiple read commands. (See Section 8.32.)

Fast Read Quad I/O in QPI Mode

When QPI mode is enabled, the number of dummy clocks is configured by the Set Read Parameters (C0h) command to accommodate a wide range applications with different needs for either maximum Fast Read frequency or minimum data access latency. The number of dummy clock cycles can be configured as either 4, 6 or 8 by setting bits P[5:4] in the 8-bit parameter of the Set Read Parameters (C0h) command as shown in Table 12, Encoding of P[5:4] Bits. The default number of dummy clocks upon power up or after a Reset (99h) command is four.

The Continuous Read Mode feature is also available in QPI mode for Fast Read Quad I/O command. In QPI mode, the Continuous Read Mode bits M7-0 are also considered as dummy clocks.

The Wrap Around feature is not available in QPI mode for Fast Read Quad I/O command. To perform a read operation with fixed data length wrap around in QPI mode, a Burst Read with Wrap (0Ch) command must be used. For more information, see Section 8.33, Burst Read with Wrap (0Ch).

Figure 24. Fast Read Quad I/O Command (Initial command or previous M7-0 ≠ Axx, QPI mode)

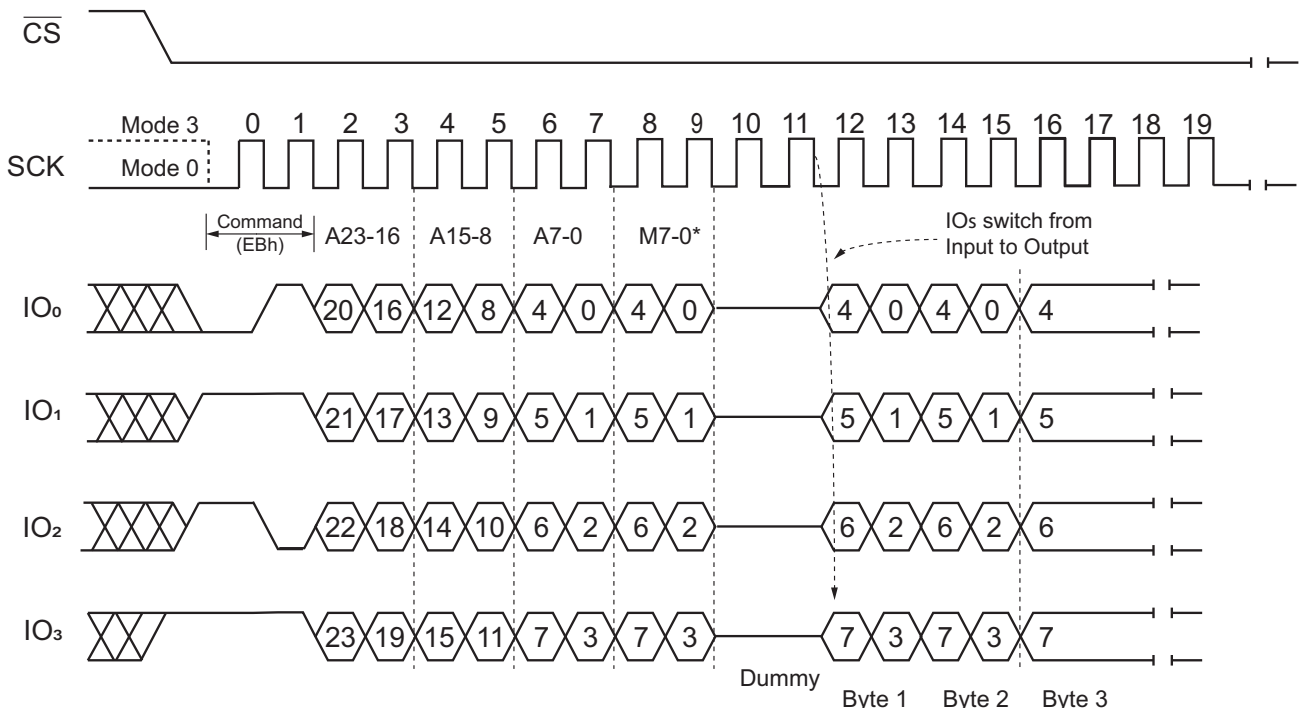

8.15 Page Program (02h)

The Page Program command is for programming the memory to be 0. A Write Enable command must be issued before the device accept the Page Program Command (Status Register bit WEL= 1). After the Write Enable (WREN) command has been decoded, the device sets the Write Enable Latch (WEL). The command is entered by driving the \overline{CS} pin low and then sending the command code 02h followed by a 24-bits address (A23-A0) and at least one data byte on the SI pin. The \overline{CS} pin must be driven low for the entire time of the command while data is being sent to the device. (See Figure 25 and Figure 26.)

If an entire 256 byte page is to be programmed, the last address byte (the 8 least significant address bits) should be set to 0. If the last address byte is not zero, and the number of clocks exceeds the remaining page length, the addressing wraps around to the beginning of the page. In some cases, less than 256 bytes (a partial page) can be programmed without having any effect on other bytes within the same page. One condition to perform a partial page program is that the number of clocks cannot exceed the remaining page length. If more than 256 bytes are sent to the device the addressing wraps around to the beginning of the page and overwrites previously sent data.

The \overline{CS} pin must be driven high after the eighth bit of the last byte has been latched. If this is not done, the Page Program command is not executed. After \overline{CS} is driven high, the self-timed Page Program command commences for a time duration of t_{pp} (see Table 26, AC Electrical Characteristics). While the page program operation is in progress, the Read Status Register command may still be accessed for checking the status of the BUSY bit. The BUSY bit is a 1 during the Page Program cycle and becomes a 0 when the cycle is finished and the device is ready to accept other commands again. When the BUSY bit is asserted, the Write Enable Latch (WEL) bit in the Status Register is cleared to 0.

Figure 25. Page Program Command (SPI Mode)

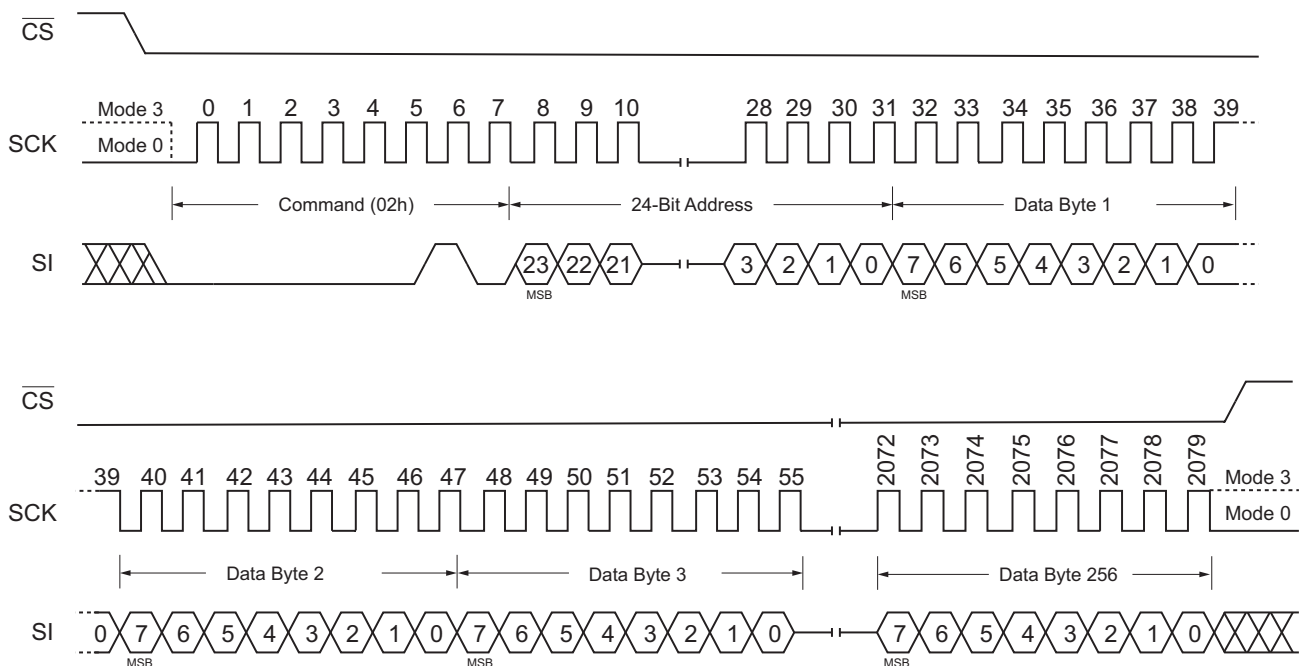
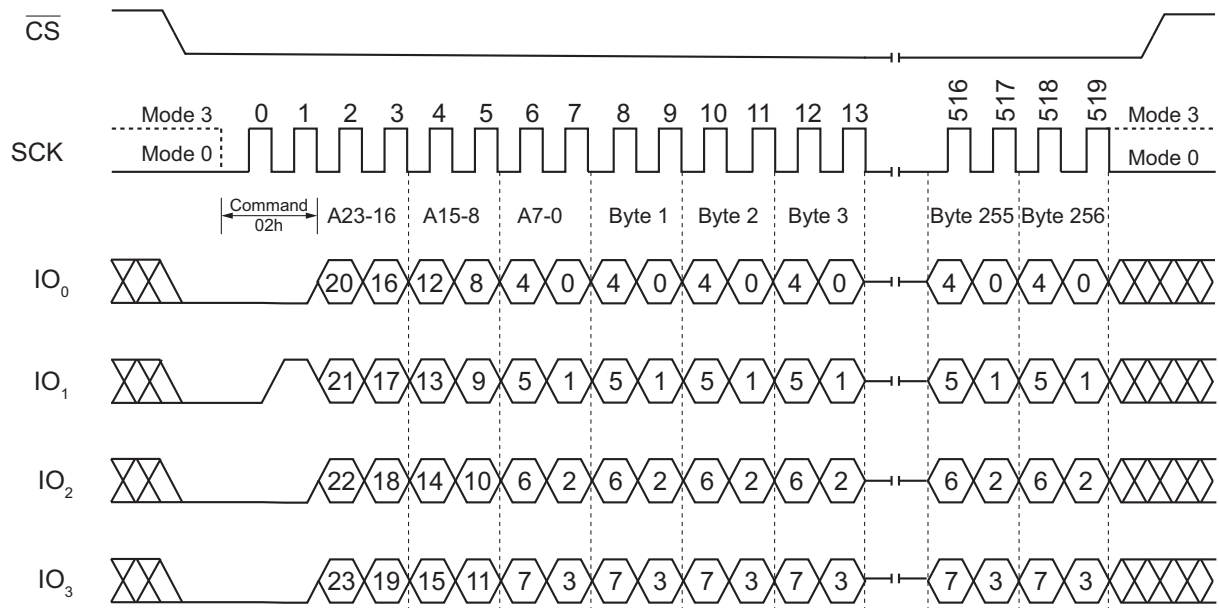

Figure 26. Page Program Command (QPI Mode)



8.16 Quad Page Program (33h)

The Quad Page Program command is to program the memory as being 0 at previously erased memory areas. The Quad Page Program requires four pins: I/O₀, I/O₁, I/O₂, and I/O₃, as address and data inputs, which can improve performance. A system using a faster clock speed does not get more benefit for the Quad Page Program as the required internal page program time is far more than the time data clock-in.

To use Quad Page Program command, the Quad Enable bit must be set. A Write Enable command must be executed before the device accepts the Quad Page Program command (Status Register-1, WEL = 1). The command is initiated by driving the CS pin low then sending the command code 33h followed by a 24-bit address (A23-A0) and at least one data, into the I/O pins. The CS pin must be held low for the entire length of the command while data is being sent to the device. All other functions of Quad Page Program command are the same as the standard Page Program command. (See Figure 27 and Figure 28.)

Figure 27. Quad Page Program Command (SPI mode)

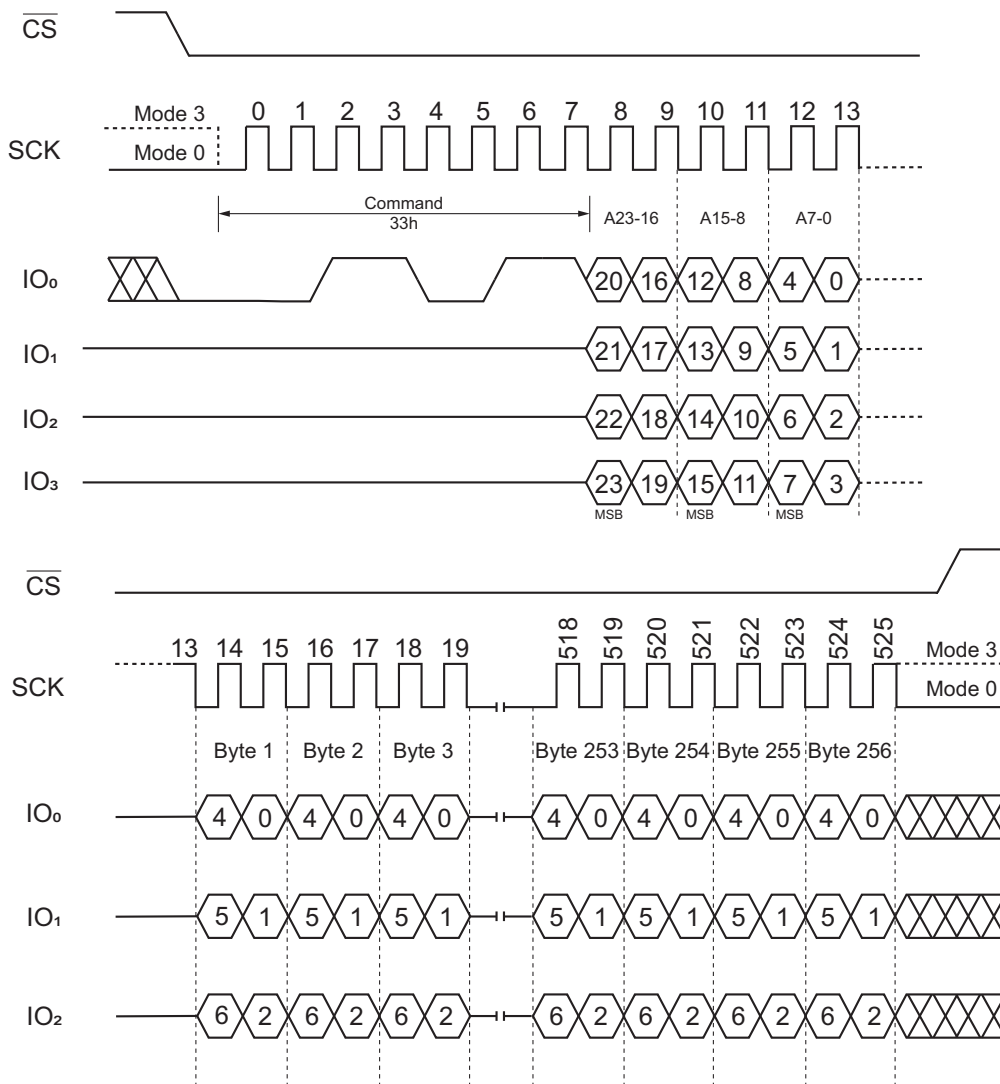
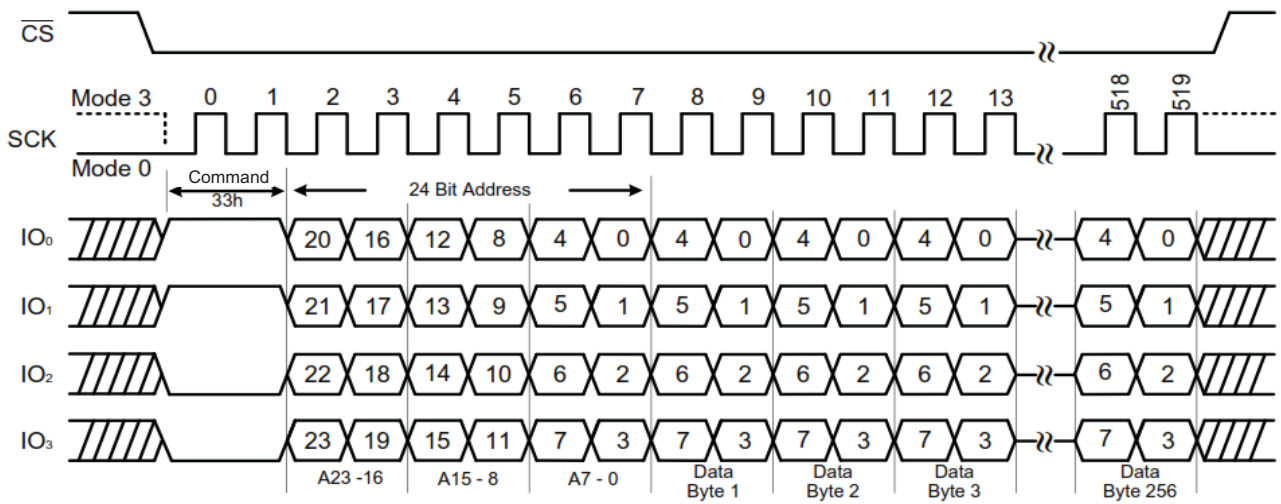

Figure 28. Quad Page Program Command (QPI mode)



8.17 4 Kbyte Block Erase (20h)

The Block Erase command is to erase the data of the selected block as being 1. The command is used for 4K-byte block. Prior to the Block Erase command, the Write Enable (06h) command must be issued. The command is initiated by driving the \overline{CS} pin low and shifting the command code 20h followed by a 24-bit block address (A23-A0) as shown in Figure 29 and Figure 30. The \overline{CS} pin must go high after the eighth bit of the last byte has been latched in, otherwise the Block Erase command is not executed. After \overline{CS} goes high, the self-timed Block Erase command commences for a time duration of t_{SE} (see Table 26, AC Electrical Characteristics).

While the block erase operation is in progress, the Read Status Register (05h) command may still be accessed for checking the status of the BUSY bit. The BUSY bit is a 1 during the block erase operation and becomes a 0 when the cycle is finished and the device is ready to accept other commands again. When the BUSY bit is asserted, the Write Enable Latch (WEL) bit in the Status Register is cleared to 0.

Figure 29. Block Erase Command (SPI Mode)

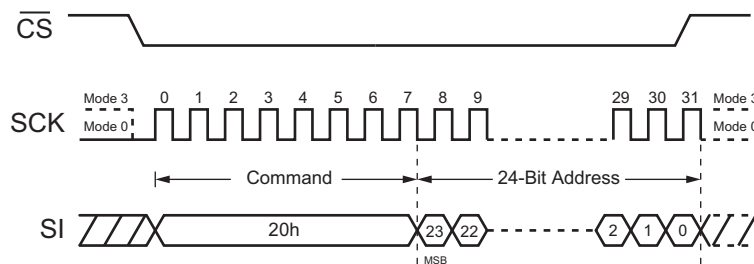
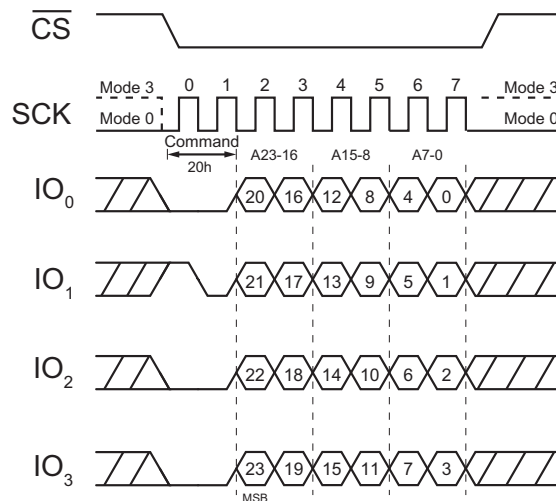

Figure 30. Block Erase Command (QPI Mode)



8.18 32 Kbyte Block Erase (52h)

The 32 kB Block Erase command is used for a 32 Kbyte block erase operation. Prior to the Block Erase Command, a Write Enable (06h) command must be issued. The command is initiated by driving the \overline{CS} pin low and shifting the command code 52h followed by a 24-bit block address (A23-A0). See Figure 31 and Figure 32 below. The \overline{CS} pin must go high after the eighth bit of the last byte has been latched in, otherwise the Block Erase command is not executed. After \overline{CS} is driven high, the self-timed Block Erase command commences for a time duration of t_{BE1} (see Table 26, AC Electrical Characteristics).

While the block erase operation is in progress, the Read Status Register (05h) command may still be used to read the status of the BUSY bit. The BUSY bit is a 1 during the block erase operation and becomes a 0 when the cycle is finished and the device is ready to accept other commands again. When the BUSY bit is asserted, the Write Enable Latch (WEL) bit in the Status Register is cleared to 0.

Figure 31. 32 kB Block Erase Command (SPI Mode)

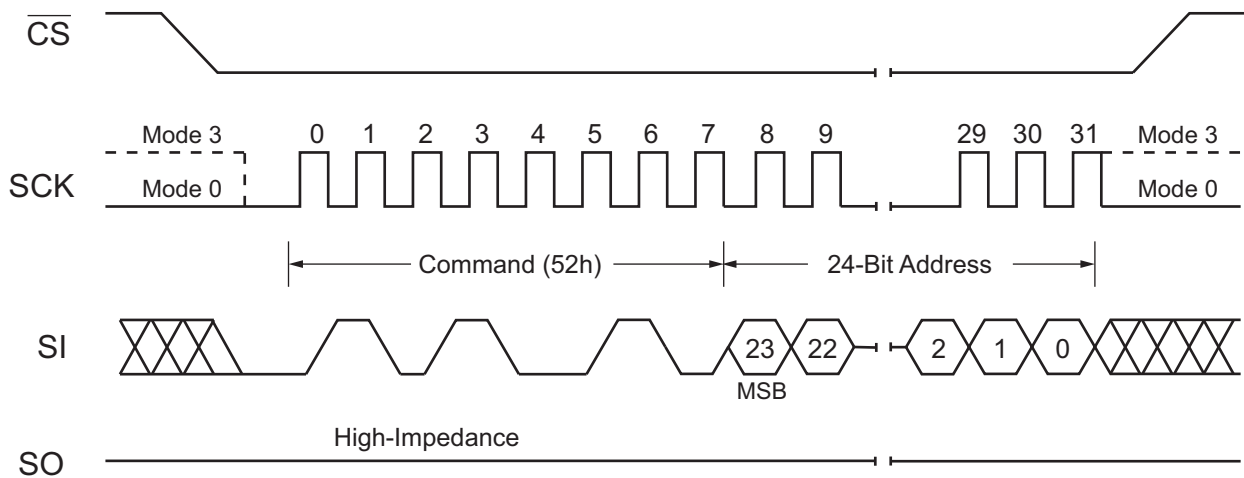
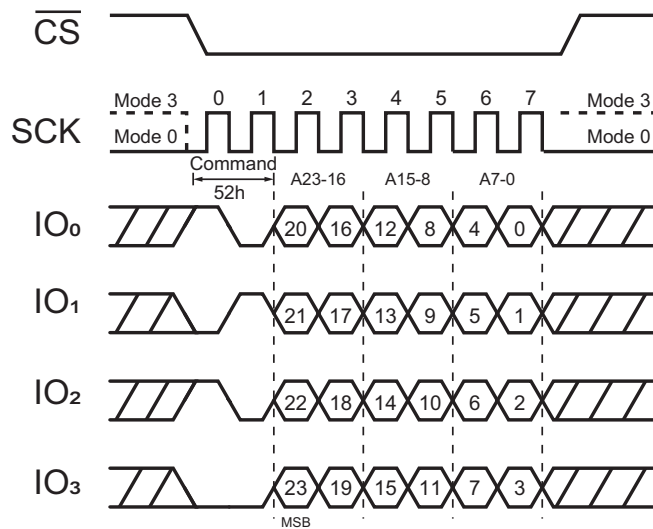

Figure 32. 32 kB Block Erase Command (QPI Mode)



8.19 64 Kbyte Block Erase (D8h)

The 64 kB Block Erase command is to erase a 64 Kbyte block of memory. Prior to the Block Erase Command, a Write Enable (06h) command must be issued. The command is initiated by driving the \overline{CS} pin low and shifting the command code D8h followed by a 24-bit block address (A23-A0). See Figure 33 and Figure 34 below. The \overline{CS} pin must go high after the eighth bit of the last byte has been latched in, otherwise, the Block Erase command is not executed. After \overline{CS} is driven high, the self-timed Block Erase command commences for a time duration of t_{BE2} (see Table 26, AC Electrical Characteristics).

While the block erase operation is in progress, the Read Status Register (05h) command may still be used to read the status of the BUSY bit. The BUSY bit is a 1 during the Block Erase cycle and becomes a 0 when the cycle is finished and the device is ready to accept other commands again. When the BUSY bit is asserted, the Write Enable Latch (WEL) bit in the Status Register is cleared to 0.

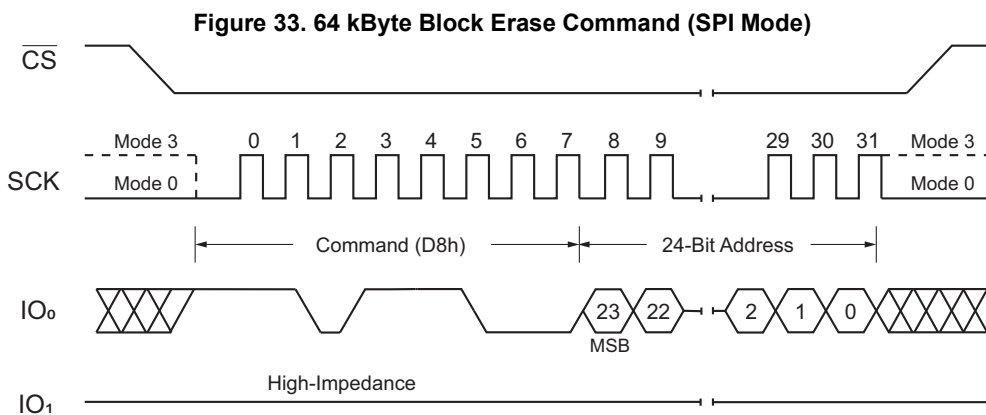
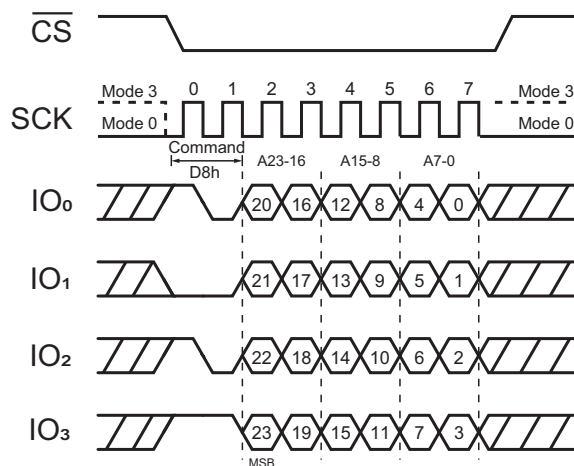

Figure 34. 64 kByte Block Erase Command (QPI Mode)



8.20 Chip Erase (C7h / 60h)

The Chip Erase command sets all bits in the memory to 1. Prior to the Chip Erase command, a Write Enable (06h) command must be issued. The command is initiated by driving the \overline{CS} pin low and shifting the command code C7h or 60h. See Figure 35 below. The \overline{CS} pin must go high after the eighth bit of the last byte has been latched in, otherwise, the Chip Erase command is not executed. After \overline{CS} is driven high, the self-timed Chip Erase command commences for a duration of t_{CE} (see Table 26, AC Electrical Characteristics).

While the chip erase operation is in progress, the Read Status Register (05h) command may still be accessed to check the status of the BUSY bit. The BUSY bit is 1 during the chip erase operation and becomes a 0 when the cycle is finished and the device is again ready to accept other commands. When the BUSY bit is asserted, the Write Enable Latch (WEL) bit in the Status Register is cleared to 0.

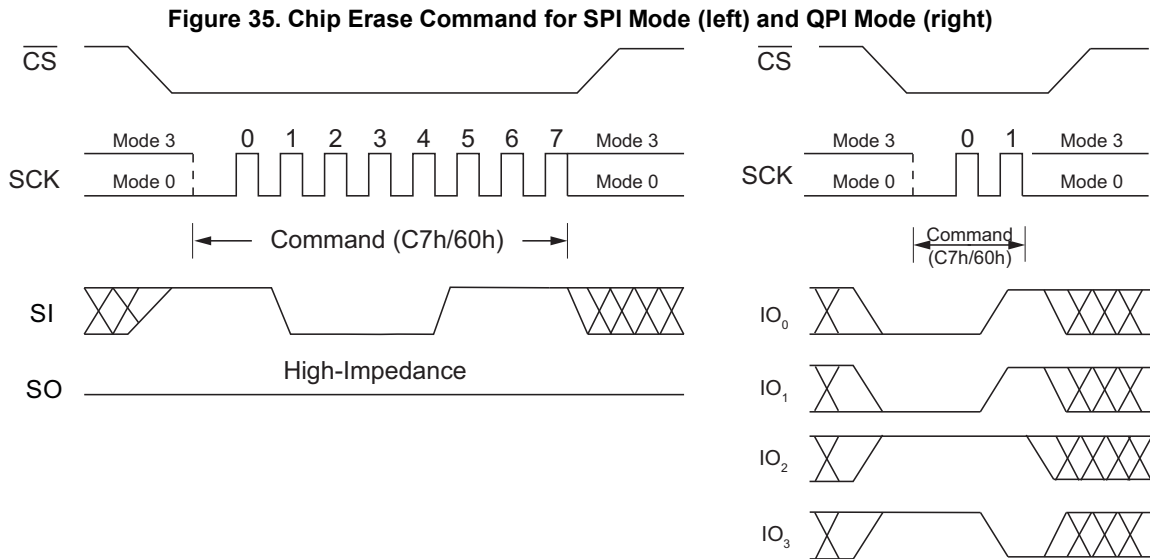

8.21 Erase / Program Suspend (75h)

The Erase/Program Suspend command allows the system to interrupt a Block Erase operation, or a Page Program, Quad Data Input Page Program, Quad Page Program operation.

The Erase Suspend is valid only during the Block or Block erase operation. The Write Status Register-1 (01h), Write Status Register-2 (31h) command and Erase commands (20h, 52h, D8h, C7h, 60h) are not allowed during an Erase Suspend operation. During the Chip Erase operation, the Erase Suspend command is ignored.

Program Suspend is valid only during the Page Program, Quad Data Input Page Program or Quad Page Program operation. The Write Status Register-1 (01h), Write Status Register-2 (31h) command, Program commands (02h and 33h) and Erase Commands (20h, 52h, D8h, C7h, 60h) are not allowed during Program Suspend.

The Erase/Program Suspend command 75h is accepted by the device only if the SUS bit in the Status Register equals to 0 and the BUSY bit equals to 1 while a Block Erase or a Page Program operation is on-going. If the SUS bit equals to 1 or the BUSY bit equals to 0, the Suspend command is ignored by the device. A maximum time of t_{SUS} (see Table 26, AC Electrical Characteristics) is required to suspend the erase or program operation. After Erase/Program Suspend, the SUS bit in the Status Register is set (0 to 1) immediately and the BUSY bit in the Status Register is cleared (1 to 0) within t_{SUS} . For a previously resumed Erase/Program operation, it is also required that the Suspend command 75h is not issued earlier than a minimum of time of t_{SUS} following the preceding Resume command 7Ah.

A read operation from an 8-Mbit area (referred to as a physical block) that includes a suspended area might provide unreliable data. For the definition of the physical block and for the techniques to ensure high data integrity, see application note AN-500.

Unexpected power off during the Erase/Program suspend state resets the device and release the suspend state. The SUS bit in the Status Register also resets to 0. The data within the page, or block that was being suspended may become corrupted. It is recommended for the user to implement system design techniques against the accidental power interruption and preserve data integrity during erase/program suspend state. (See [Figure 36](#) and [Figure 37](#).)

Figure 36. Erase Suspend Command (SPI Mode)

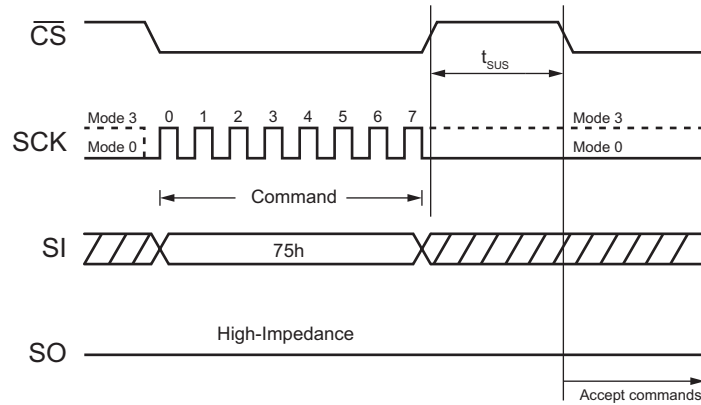
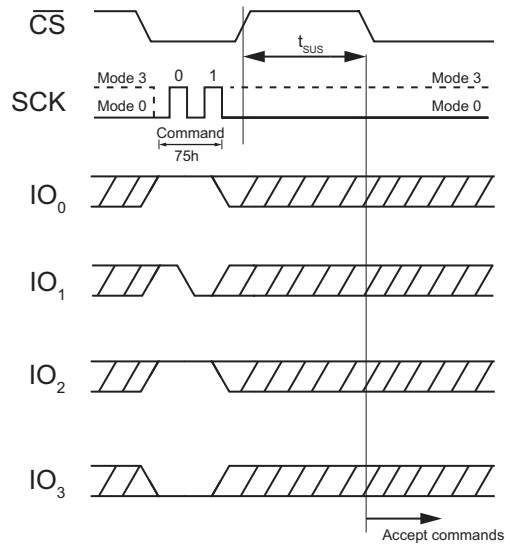

Figure 37. Erase Suspend Command (QPI Mode)



8.22 Erase / Program Resume (7Ah)

The Erase/Program Resume command 7Ah is to restart the Block Erase operation or the Page Program operation upon an Erase/Program Suspend. The Resume command 7Ah is accepted by the device only if the SUS bit in the Status Register equals to 1 and the BUSY bit equals to 0. After the command is issued, the SUS bit is cleared immediately, the BUSY bit is set within 200 ns, and the block completes the erase operation, or the page completes the program operation. If the SUS bit equals to 0 or the BUSY bit equals 1, the Resume command 7Ah is ignored by the device.

Resume command cannot be accepted if the previous Erase/Program Suspend operation was interrupted by unexpected power off. It is also required that a subsequent Erase/Program Suspend command not to be issued within a minimum of time of t_{SUS} following a previous Resume command. See [Figure 38](#) and [Figure 39](#).

Figure 38. Erase / Program Resume Command (SPI Mode)

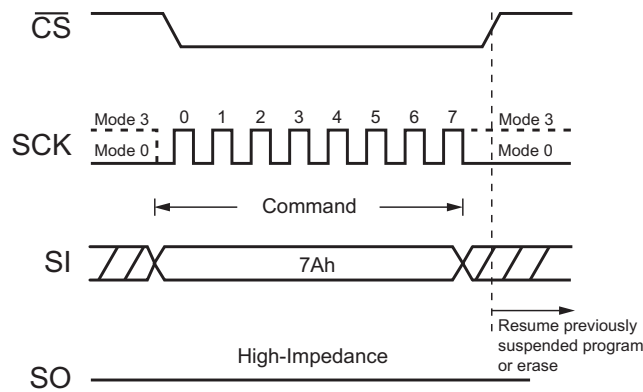
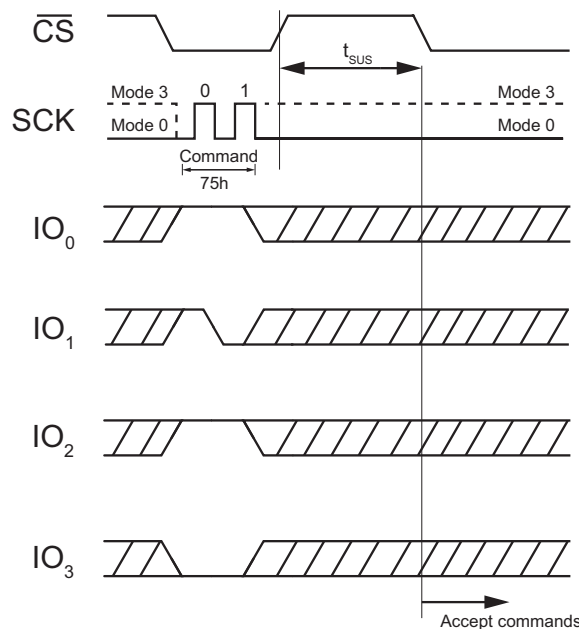

Figure 39. Erase / Program Resume Command (QPI Mode)



8.23 Deep Power-Down (B9h)

Executing the Deep Power-Down command is the best way to put the device in the lowest power consumption. The Deep Power-Down command reduces the standby current (from I_{CC1} to I_{CC2} , as specified in [Table 26, AC Electrical Characteristics](#)). The command is entered by driving the \overline{CS} pin low with following the command code B9h. See [Figure 40](#) and [Figure 41](#).

The \overline{CS} pin must go high exactly at the byte boundary (the latest eighth bit of command code been latched-in); otherwise, the Deep Power-Down command is not executed. After \overline{CS} goes high, it requires a delay of t_{DP} and the Deep Power-Down mode is entered. While in the Deep Power-Down state, the Release Deep Power-Down / Device ID (ABh) command, which restores the device to normal operation, is recognized. All other commands are ignored, including the Read Status Register (05h) command, which is always available during normal operation.

Figure 40. Deep Power-Down Command (SPI Mode)

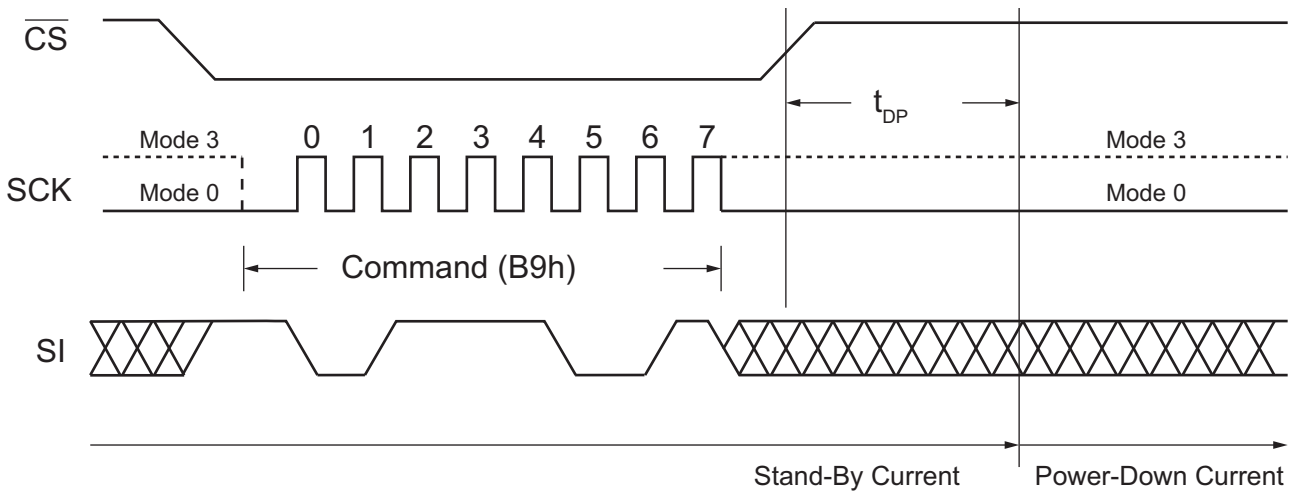
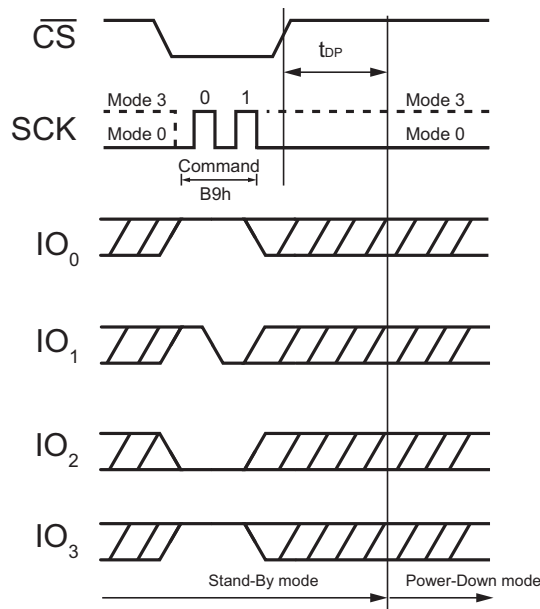

Figure 41. Deep Power-Down Command (QPI Mode)



8.24 Release Deep Power-Down / Device ID (ABh)

The Release Deep Power-Down / Device ID command is a multi-purpose command. It can be used to release the device from the Deep Power-Down state and also obtain the device identification (ID).

The command is issued by driving the \overline{CS} pin low, sending the command code ABh and driving \overline{CS} high as shown in Figure 42 and Figure 43. The Release from Deep Power-Down command requires the time duration of t_{RES1} (see Table 26, AC Electrical Characteristics). The \overline{CS} pin must keep high during the t_{RES1} time duration.

The Device ID can be read during SPI mode only. In other words, Device ID feature is not available in QPI mode for Release Deep Power-Down/Device ID command. To obtain the Device ID in SPI mode, the command is initiated by driving the \overline{CS} pin low and sending the command code ABh with following 3-dummy bytes. The Device ID bits are then shifted on the falling edge of SCK with most significant bit (MSB) first as shown in Figure 44. After \overline{CS} is driven high it must keep high for a time duration of t_{RES2} (See Table 26, AC Electrical Characteristics). The Device ID can be read continuously. The command is completed by driving \overline{CS} high.

If the Release from Deep Power-Down /Device ID command is issued while an Erase, Program or Write cycle is in process (when BUSY equals 1) the command is ignored and does not have any effects on the current cycle.

Figure 42. Release Power-Down Command (SPI Mode)

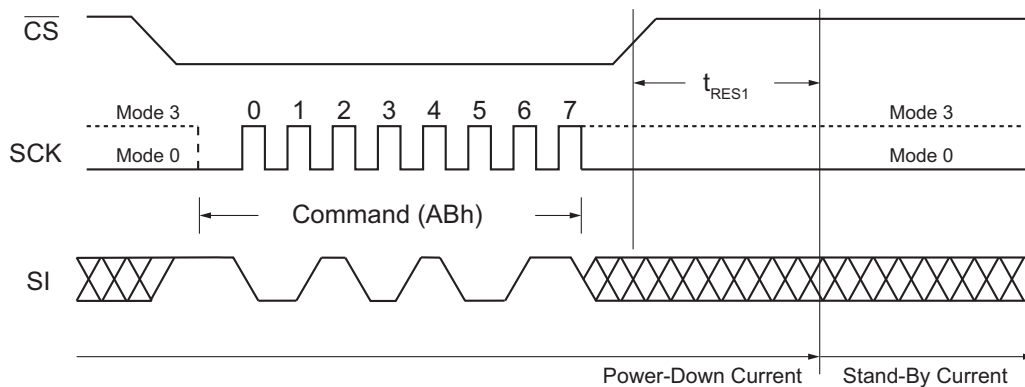

Figure 43. Release Power-Down Command (QPI Mode)

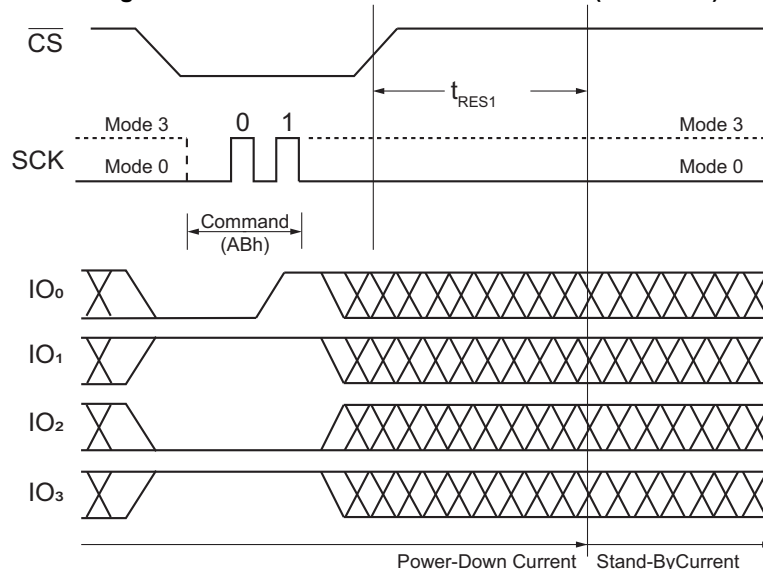
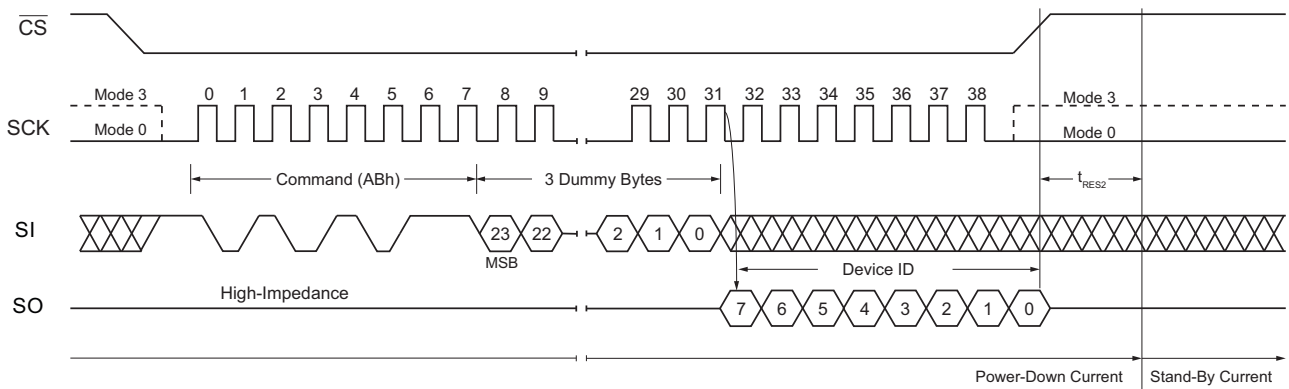

Figure 44. Release Power-Down / Device ID Command (SPI Mode)



8.25 Read Manufacturer / Device ID I/O (90h)

The Read Manufacturer/ Device ID command provides both the JEDEC assigned manufacturer ID and the specific device ID. This command can be issued in both SPI mode and QPI mode. In SPI mode, the 90h command is called a 1-1-1 transfer, where the command, address, and data are all driven on a single pin (SI for command and address, and SO for data). In QPI mode, the 90h command is called a 4-4-4 transfer, where the command, address, and data are driven on the bidirectional IO₀ - IO₃ pins.

Note that in QPI mode, the following events must occur in this order:

1. Set the QE bit in Status Register-2
2. Execute the QPI Enable (38h) command
3. Execute the 90h command

In SPI mode, the operation is initiated by driving the \overline{CS} pin low and then driving the command code 90h onto the SI pin, followed by a 24-bit address (A23-A0) of 000000h. The 90h command requires 8 clocks to transfer, and the 24-bit address requires 24 clocks to transfer. The Manufacturer ID for Renesas Electronics (1Fh) and the Device ID (17h) are shifted out on the SO pin on the falling edge of SCK with most significant bit (MSB) first. A minimum of 16 clocks are required to transfer the manufacturer and device ID information. If the 24-bit address is initially set to 000001h the Device ID is read first and then followed by the Manufacturer ID. The Manufacturer and Device ID can be read continuously, alternating from one to the other. The command is completed by driving \overline{CS} high.

In QPI mode, the SI, SO, \overline{WP} , and \overline{HOLD} pins are configured as bidirectional pins IO₀, IO₁, IO₂, and IO₃ respectively. The 90h operation the operation is initiated by driving the \overline{CS} pin low and then driving the command code 90h onto the IO₀ - IO₃ pins, followed by a 24-bit address (A23-A0) of 000000h. The 90h command requires 2 clocks to transfer, and the 24-bit address requires 6 clocks to transfer. The Manufacturer ID for Renesas Electronics (1Fh) and the Device ID (17h) are shifted out on the bidirectional IO₀ - IO₃ pins on the falling edge of SCK, with most significant bit (MSB) first. A minimum of 4 clocks are required to transfer the manufacturer and device ID information. If the 24-bit address is initially set to 000001h the Device ID is read first and then followed by the Manufacturer ID. The Manufacturer and Device ID can be read continuously, alternating from one to the other. The command is completed by driving \overline{CS} high.

Figure 45 shows the 90h command as executed in SPI mode. In this mode the command and address are driven on the SI pin.

Figure 46 shows the 90h command as executed in QPI mode. In this mode the command and address are driven on all four I/O pins.

Figure 45. Read Manufacturer/ Device ID Command (SPI Mode)

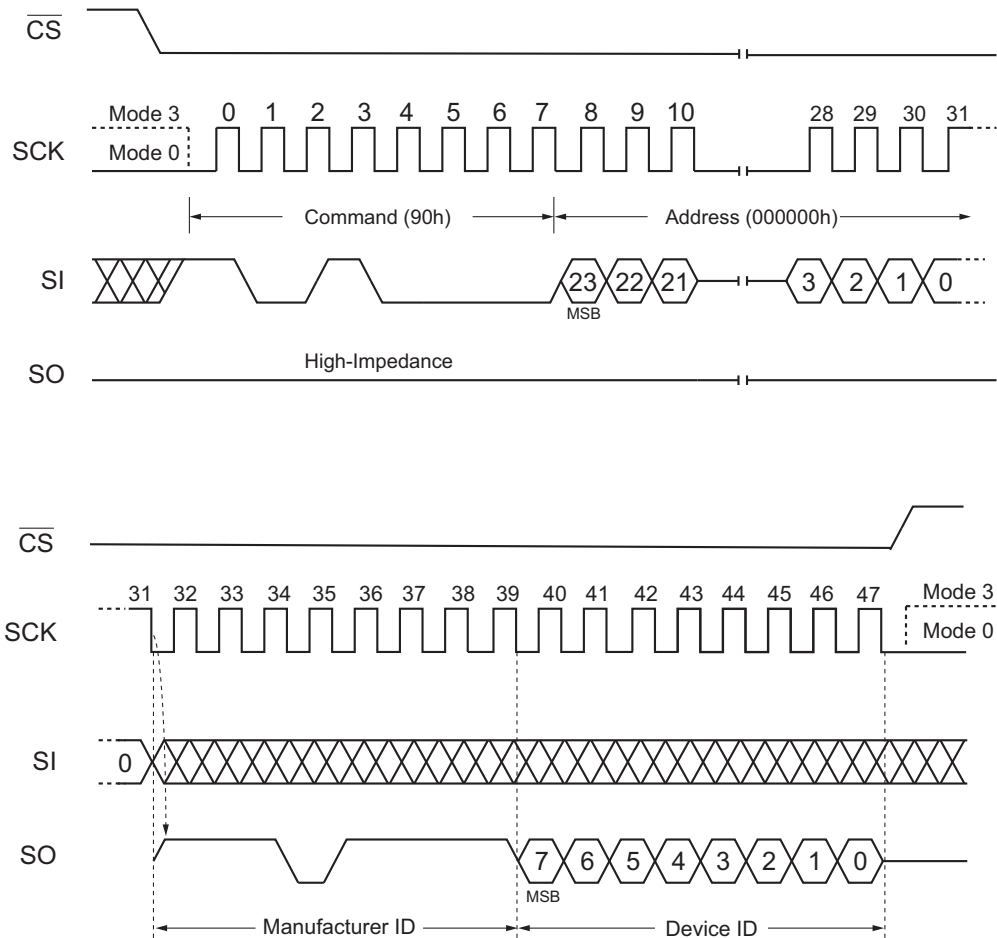
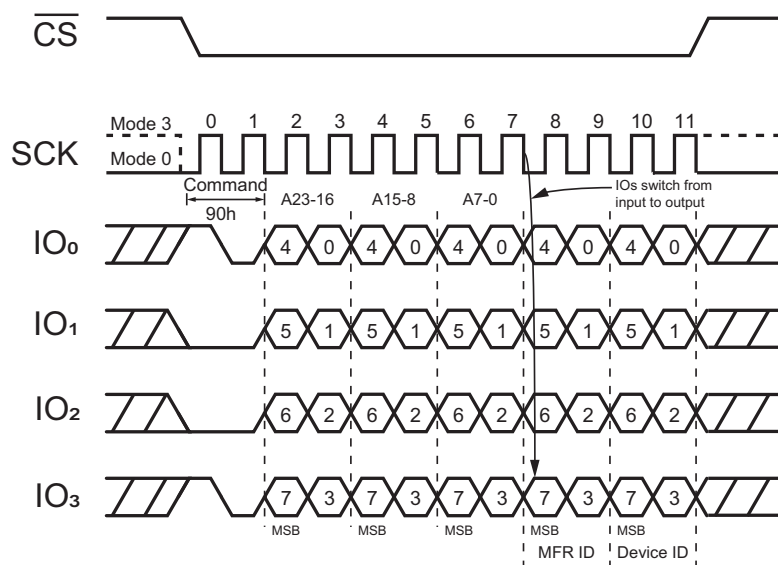

Figure 46. Read Manufacturer/ Device ID Command (QPI Mode)



8.26 Read Manufacturer / Device ID Dual I/O (92h)

The Read Manufacturer/ Device ID Dual I/O command provides both the JEDEC assigned manufacturer ID and the specific device ID. This command allows the address and manufacturer/device ID information to be driven on both the SI and SO pins. During the address transfer, the SI and SO pins are inputs, allowing the 24-bit address to be transferred in only 12 clocks. Device hardware then switches the SI and SO pins to outputs and drives the manufacturer/device ID information on these two pins, again requiring only half the number of clocks as required by the 90h command. The 92h command is called a 1,2,2 transfer, where the command is transferred on a single pin (SI), and the address and data are driven on two pins (SI and SO).

The command is initiated by driving the \overline{CS} pin low and shifting the command code 92h followed by a 24-bit address (A23-A0) of 000000h. The Manufacturer ID for Renesas Electronics (1Fh) and the Device ID (17h) are then shifted out on the falling edge of SCK with most significant bit (MSB) first as shown in Figure 47. If the 24-bit address is initially set to 000001h the Device ID is read first and then followed by the Manufacturer ID. The Manufacturer and Device ID can be read continuously, alternating from one to the other. The command is completed by driving \overline{CS} high.

Figure 47. Read Dual Manufacturer/ Device ID Dual I/O Command (SPI Mode)

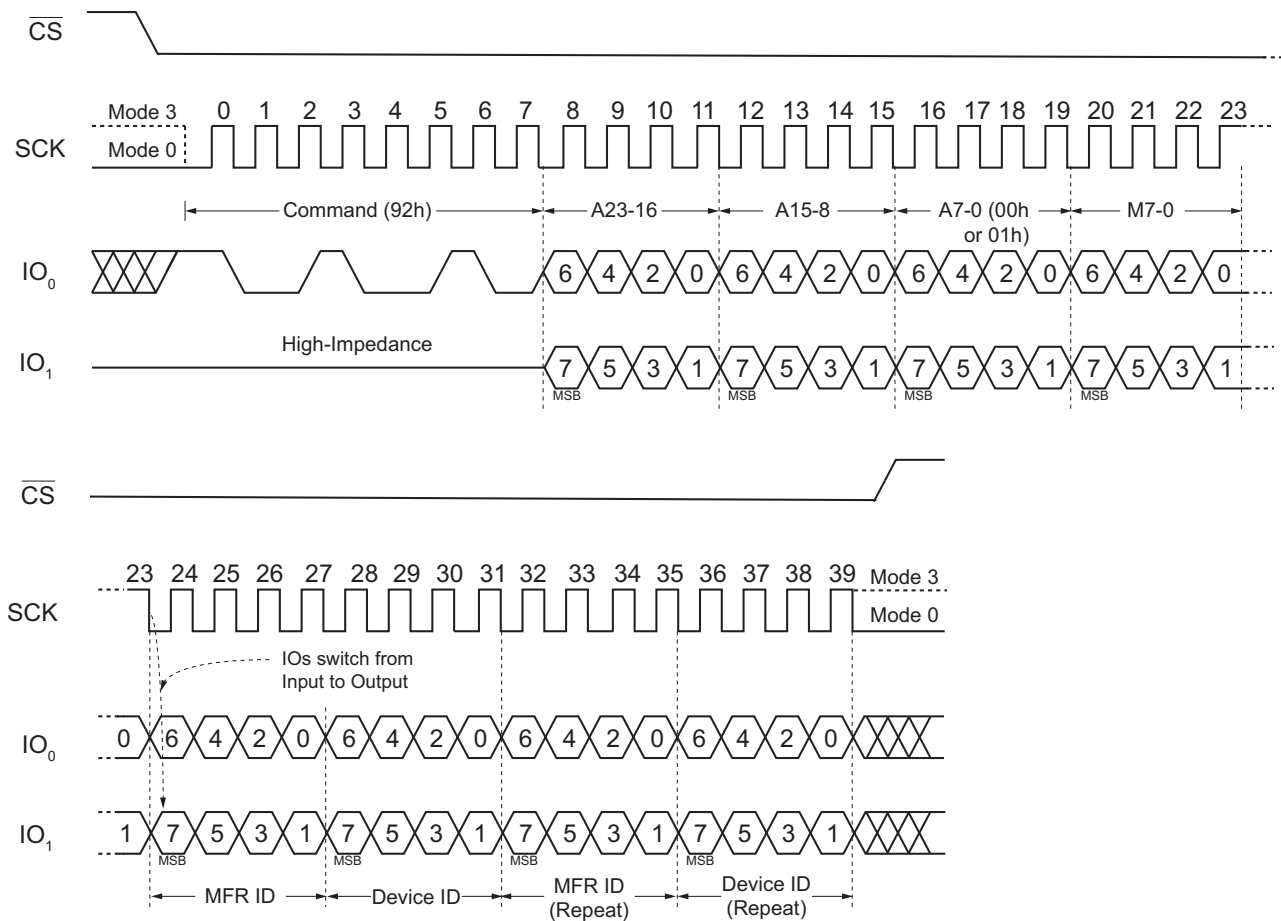

8.27 Read Manufacturer / Device ID Quad I/O (94h)

The Read Manufacturer/Device ID Quad I/O command provides both the JEDEC assigned manufacturer ID and the specific device ID. This command allows both address and manufacturer/device ID information to be driven on the SI (IO₀), SO (IO₁), WP (IO₂), and HOLD (IO₃) pins. During the address transfer, the IO₀, IO₁, IO₂, and IO₃ pins are inputs, allowing the 24-bit address to be transferred in only 6 clocks. Device hardware then switches these pins to outputs and drives the manufacturer/device ID information on these pins, transferring the information in one-fourth the number of clocks required by the 90h command. The 94h command is called a 1,4,4 transfer, where the command is transferred on a single pin (IO₀), and the address and data are driven on four pins (IO₀ - IO₃).

The command is initiated by driving the \overline{CS} pin low and shifting the command code 94h followed by a 24-bit address (A23-A0) of 000000h. After which, the Manufacturer ID for Renesas Electronics (1Fh) and the Device ID (17h) are shifted out on the falling edge of SCK with most significant bit (MSB) first as shown in Figure 48. If the 24-bit address is initially set to 000001h the Device ID is read first and then followed by the Manufacturer ID. The Manufacturer and Device ID can be read continuously, alternating from one to the other. The command is completed by driving \overline{CS} high.

Figure 48. Read Quad Manufacturer/ Device ID Quad I/O Command (SPI Mode)

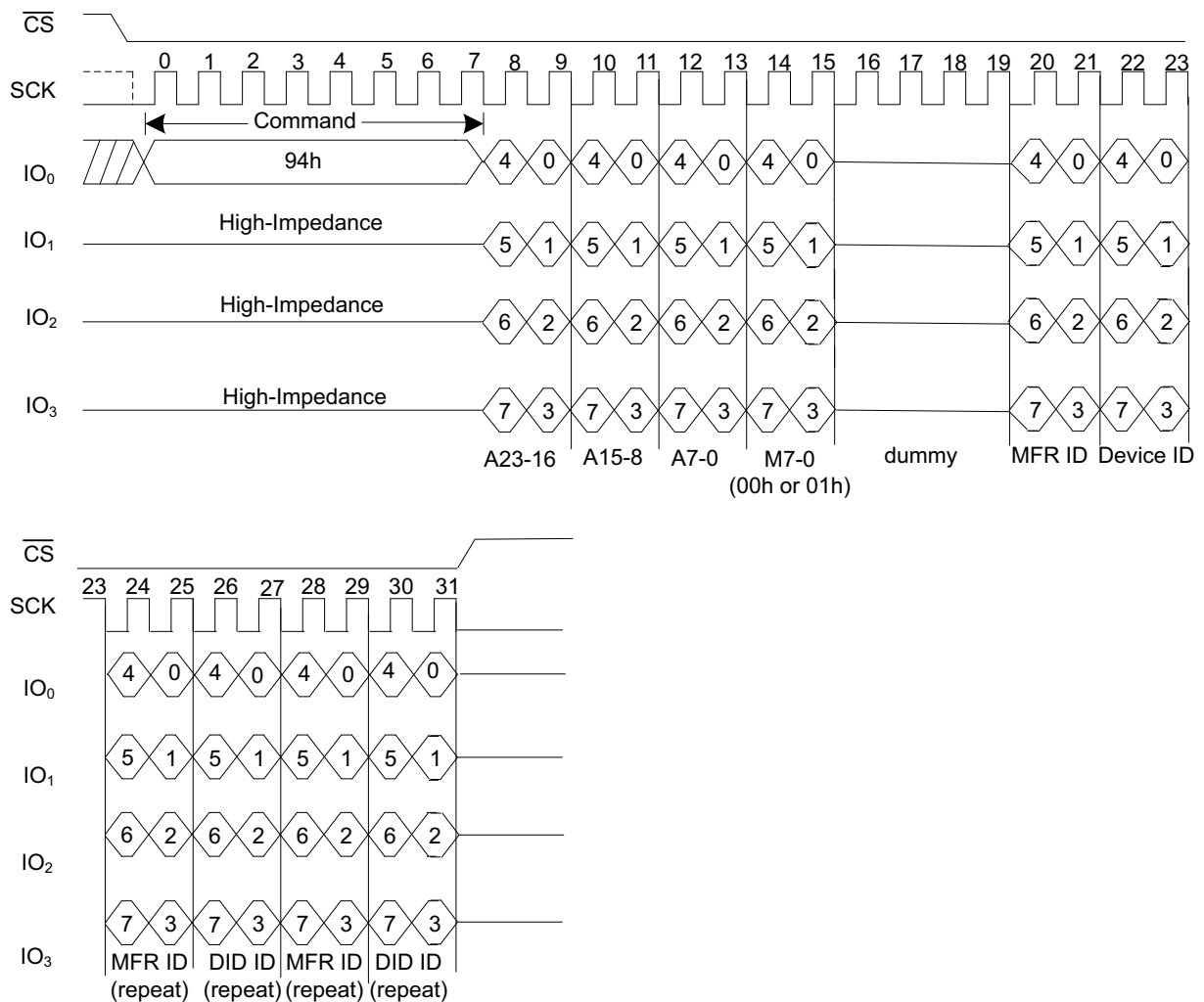

8.28 JEDEC ID (9Fh)

For compatibility reasons, the AT25QL641 provides several commands to electronically determine the identity of the device. The Read JEDEC ID command is compliant with the JEDEC standard for SPI compatible serial Flash memories that was adopted in 2003.

The command is entered by driving the \overline{CS} pin low with following the command code 9Fh. The JEDEC assigned Manufacturer ID byte for Renesas Electronics (1Fh) and two Device ID bytes, Memory Type (ID15-ID8) and Capacity (ID7-ID0) are then shifted out on the falling edge of SCK with most significant bit (MSB) first shown in Figure 49 and Figure 50. For memory type and capacity values, see Table 7. The JEDEC ID can be read continuously. The command is terminated by driving \overline{CS} high.

Figure 49. Read JEDEC ID Command (SPI Mode)

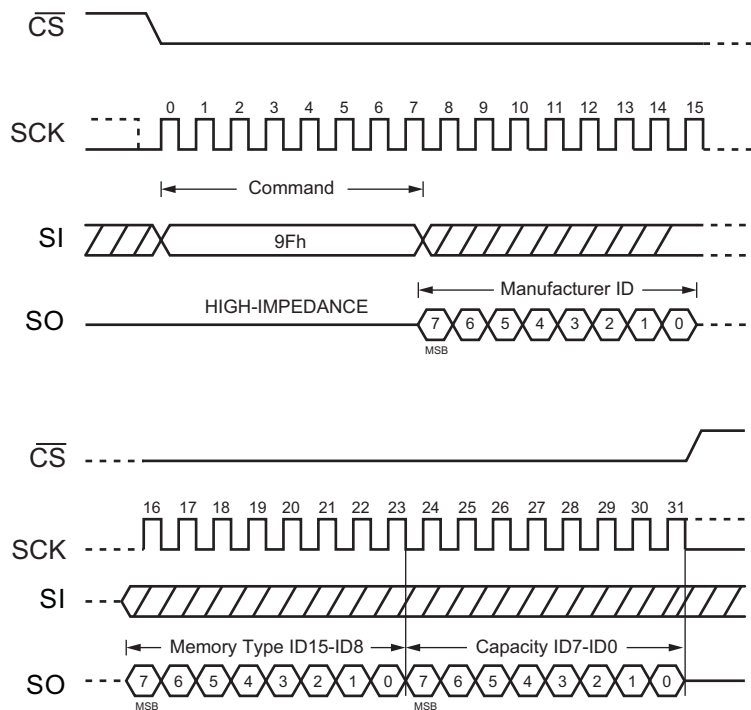
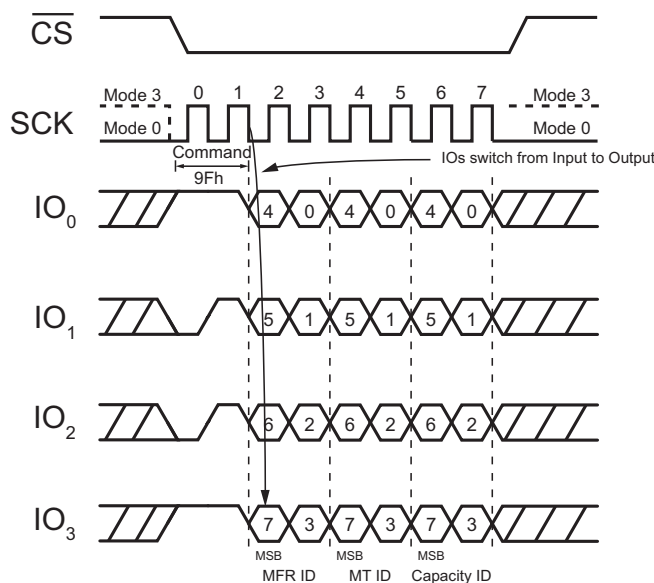

Figure 50. Read JEDEC ID Command (QPI Mode)



8.29 Enable QPI (38h)

The AT25QL641 supports both the Standard/Dual/Quad Serial Peripheral interface (SPI) and the Quad Peripheral Interface (QPI) modes. However, SPI mode and QPI mode cannot be used at the same time. The Enable QPI command is the only way to switch the device from SPI mode to QPI mode.

In order to switch the device to QPI mode, the Quad Enable (QE) bit in Status Register 2 must be set to 1 first, and an Enable QPI command must be issued. If the Quad Enable (QE) bit is 0, the Enable QPI command is ignored and the device remains in SPI mode.

After power-up, the default state of the device is SPI mode. See the command set Table 8 for all the commands supported in SPI mode and the command See Table 11 for all the commands supported in QPI mode.

When the device is switched from SPI mode to QPI mode, the existing write enable and program/erase suspend status, and the wrap length setting remains unchanged.

Figure 51. Enable QPI Command (SPI Mode only)

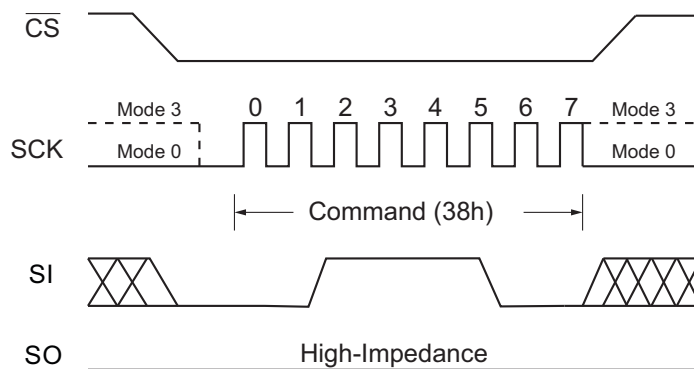

8.30 Disable QPI (FFh)

By issuing Disable QPI (FFh) command, the device is reset SPI mode. When the device is switched from QPI mode to SPI mode, the existing Write Enable Latch (WEL) and Program/Erase Suspend status, and the Wrap Length setting remains unchanged.

Figure 52. Disable QPI Command for QPI Mode

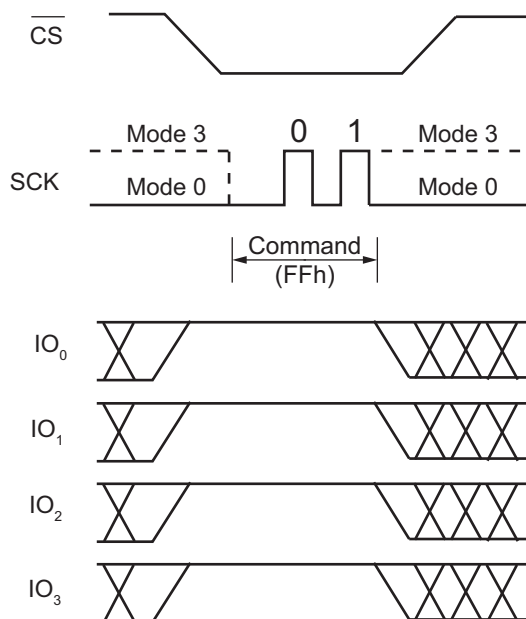

8.31 Word Read Quad I/O (E7h)

The Quad I/O dramatically reduces command overhead allowing faster random access for code execution (XiP) directly from the Quad SPI. The Quad Enable bit (QE) of Status Register-2 must be set to enable the Word Read Quad I/O command. The lowest Address bit (A0) must equal 0 and only two dummy clocks are required prior to the data output.

Continuous Read Mode

The Word Read Quad I/O command can further reduce command overhead through setting the Continuous Read Mode bits (M7-0) after the input Address bits (A23-0), as shown in Figure 53. The upper nibble of the (M7-4) controls the length of the next Word Read Quad I/O command through the inclusion or exclusion of the first byte command code. The lower nibble bits of the (M[3:0]) are don't care (X). However, the I/O pins should be high-impedance prior to the falling edge of the first data out clock.

If the continuous read mode bits $M[7-4] = Ah$, then the next Fast Read Quad I/O command (after \overline{CS} is raised and then lowered) does not require the E7h command code, as shown in Figure 54. This reduces the command sequence by eight clocks and allows the Read address to be immediately entered after \overline{CS} is asserted low. If the continuous read mode bits $M[7:4]$ do not equal to Ah (1010), the next command (after \overline{CS} is raised and then lowered) requires the first byte command code, thus returning to normal operation.

Figure 53. Word Read Quad I/O Command (Initial command or previous set M7-0 ≠ Ah, SPI Mode)

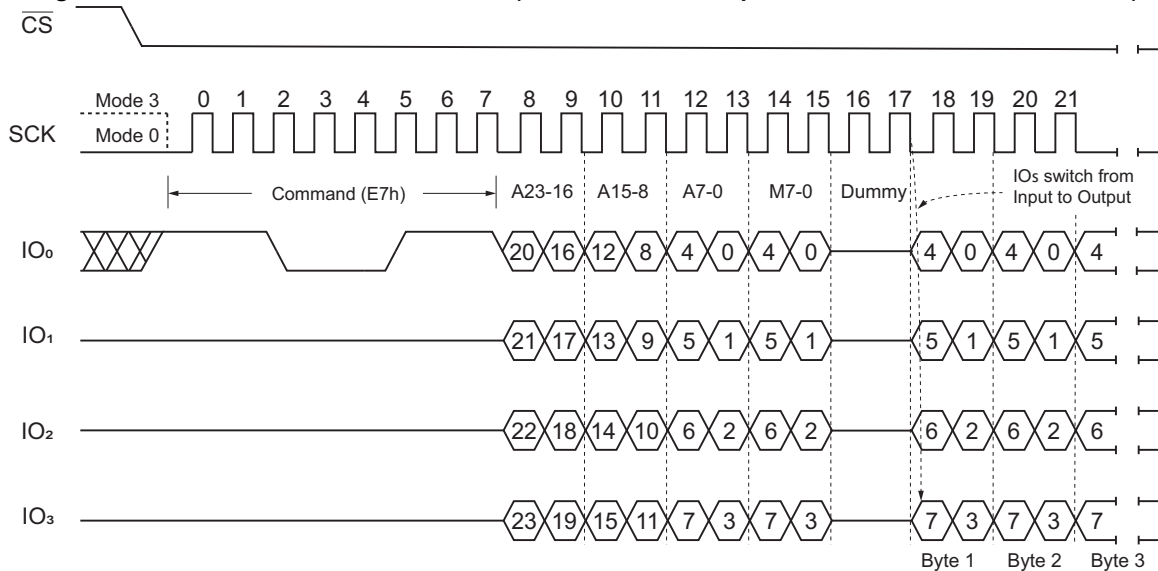
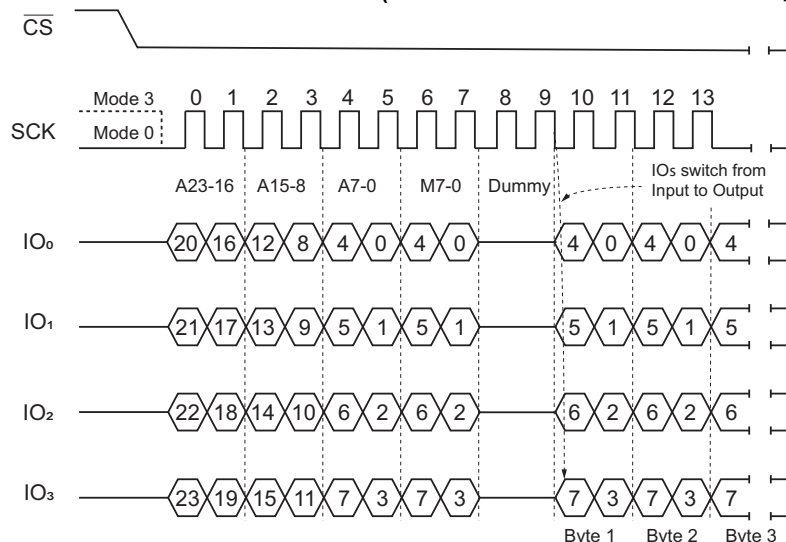

Figure 54. Word Read Quad I/O Command (Previous command set M7-0 = Ah, SPI Mode)



Wrap Around in SPI mode

The Word Read Quad I/O command can also be used to access a specific portion within a page by issuing a Set Burst with Wrap (77h) command prior to E7h. The Set Burst with Wrap (77h) command can either enable or disable the Wrap Around feature for the following E7h commands. When Wrap Around is enabled, the output data starts at the initial address specified in the command, once it reaches the ending boundary of the 8/16/32/64-byte section, the output wraps around to the beginning boundary automatically until \overline{CS} is pulled high to terminate the command.

The Set Burst with Wrap feature allows applications that use cache to quickly fetch a critical address and then fill the cache afterwards within a fixed length (8/16/32/64-byte) of data without issuing read commands.

The Set Burst with Wrap command allows three Wrap Bits, W6-4 to be set. The W4 bit is used to enable or disable the Wrap Around operation while W6-5 is used to specify the length of the wrap around section within a page.

8.32 Set Burst with Wrap (77h)

The Set Burst with Wrap (77h) command is used in conjunction with Fast Read Quad I/O and Word Read Quad I/O commands to access a fixed length of 8/16/32/64-byte section within a 256-byte page. Certain applications can benefit from this feature and improve the overall system code execution performance. Before the device can accept the Set Burst with Wrap command, the QE bit in the Status register bit must be set.

The Set Burst with Wrap command is initiated by driving the \overline{CS} pin low and then shifting the command code 77h followed by 24 dummy bits and 8 Wrap Bits, W7-0. The command sequence is shown in Set Burst with Wrap command sequence. Wrap bits W7 and W3-0 are not used.

Table 14. Encoding of the W6 - W4 Wrap Bits

W6, W5	W4 = 0		W4 = 1 (Default)	
	Wrap Around	Wrap Length	Wrap Around	Wrap Length
0 0	Yes	8-byte	No	N/A
0 1	Yes	16-byte	No	N/A
1 0	Yes	32-byte	No	N/A
1 1	Yes	64-byte	No	N/A

Once W6-4 are set by a Set Burst with Wrap command, all the following Fast Read Quad I/O and Word Read Quad I/O commands use the W6-4 setting to access the corresponding 8/16/32/64-byte section within any page.

To exit the Wrap Around function and return to normal read operation, another Set Burst with Wrap command should be issued to set W4 = 1. The default value of W4 upon power on is 1. In the case of a system reset while W4 = 0, it is recommended that the controller issues a Set Burst with Wrap command or Reset (99h) command to reset W4 = 1 prior to any normal Read commands since the AT25QL641 does not have an external hardware reset pin.

Figure 55. Set Burst with Wrap Command Sequence

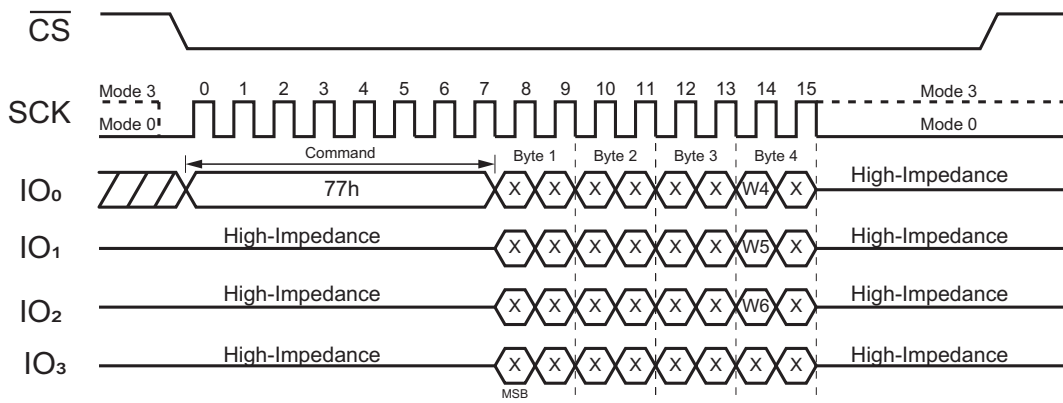

8.33 Burst Read with Wrap (0Ch)

The Burst Read with Wrap (0Ch) command provides an alternative way to perform the read operation with wrap around in QPI mode. The command is similar to the Fast Read (0Bh) command in QPI mode, except the addressing of the read operation wraps around to the beginning boundary of the wrap length once the ending boundary is reached.

The number of dummy clock cycles can be configured as either 4, 6 or 8 by setting bits P[5:4] in the 8-bit parameter of the Set Read Parameters (C0h) command as shown in [Table 12, Encoding of P\[5:4\] Bits](#).

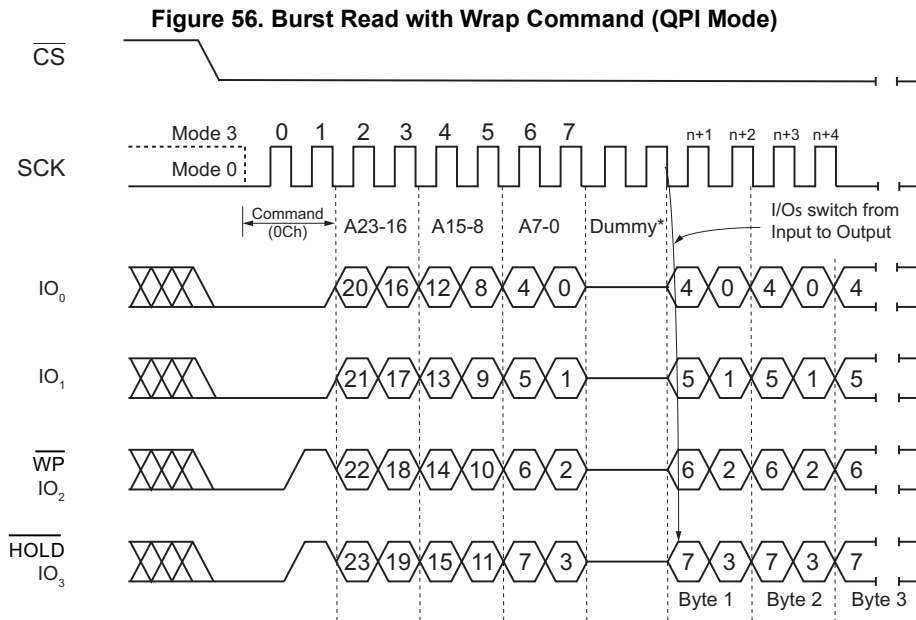

* "Set Read Parameters" command (C0h) can set the number of dummy clocks

8.34 Enable Reset (66h) and Reset (99h)

For eight-pin packages, the AT25QL641 provide a software Reset command instead of a dedicated RESET pin.

Once the Reset command is accepted, any ongoing internal operations are terminated and the device returns to its default power-on state and loses all the current volatile settings, such as Volatile Status Register bits, Write Enable Latch (WEL) status, Program/Erase Suspend status, Continuous Read Mode bit setting, Read parameter setting and Wrap bit setting.

The Enable Reset (66h) and Reset (99h) commands can be issued in either SPI mode or QPI mode. To avoid accidental reset, both commands must be issued in sequence. Any other commands other than Reset (99h) that occur after the Enable (66h) command disables the reset enable state. As such, a new sequence of Enable Reset (66h) and Reset (99h) is needed to reset the device. Once the Reset command is accepted by the device takes approximately $t_{RST} = 30 \mu s$ to reset. During this period, no commands are accepted.

Data corruption may happen if there is an on-going or suspended internal Erase or Program operation when Reset command sequence is accepted by device. It is recommended to check the BUSY bit and the SUS bit in Status Register before issuing the Reset command sequence.

Figure 57. Enable Reset and Reset Command (SPI Mode)

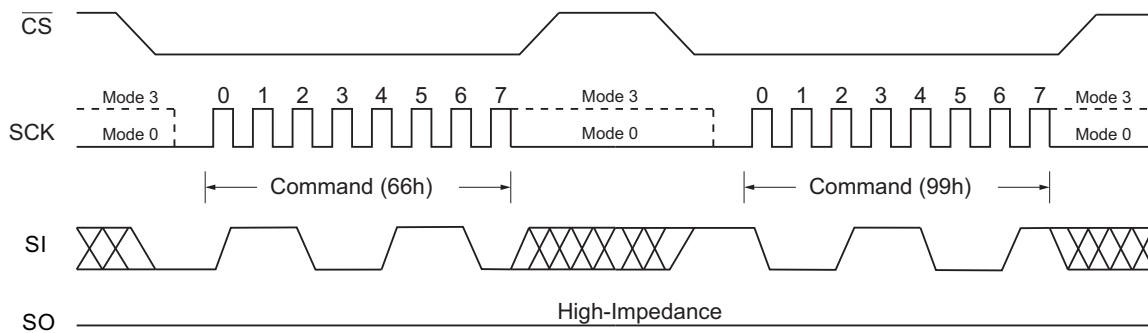
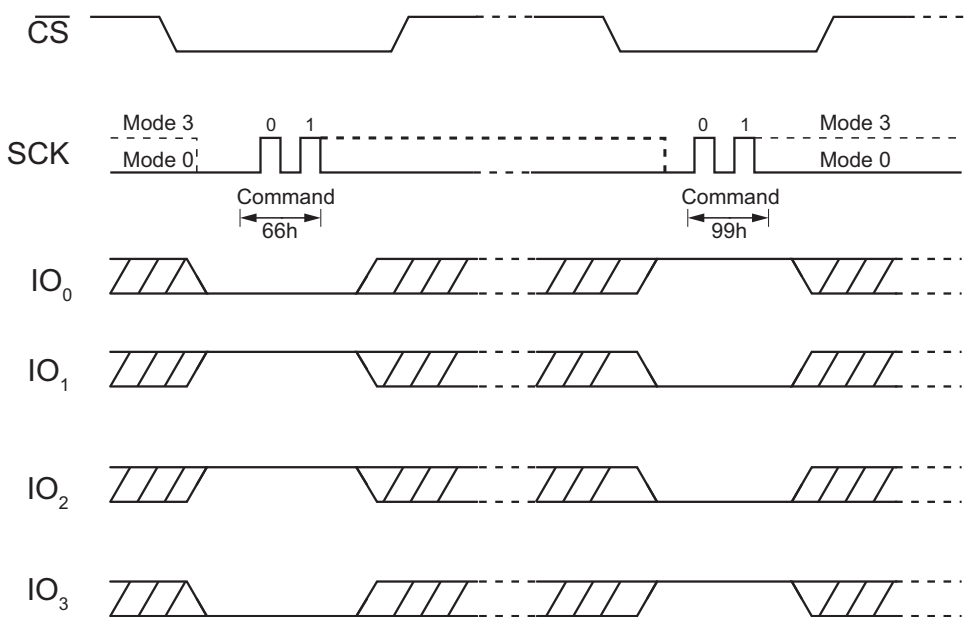

Figure 58. Enable Reset and Reset Command (QPI Mode)



8.35 Read Serial Flash Discovery Parameter (5Ah)

The Read Serial Flash Discovery Parameter (SFDP) command allows reading the Serial Flash Discovery Parameter area (SFDP). This SFDP area is composed of 2048 read-only bytes containing operating characteristics and vendor specific information. The SFDP area is factory programmed. If the SFDP area is blank, the device is shipped with all the SFDP bytes at FFh. If only a portion of the SFDP area is written to, the portion not used is shipped with bytes in the erased state (FFh).

The command sequence for the read SFDP has the same structure as that of a Fast Read command. First, the device is selected by driving Chip Select (\overline{CS}) low. Next, the 8-bit command code (5Ah) and the 24-bit address are shifted in, followed by 8 dummy clock cycles. The bytes of SFDP content are shifted out on the Serial Data Output (SO) starting from the specified address. Each bit is shifted out during the falling edge of Serial Clock (SCK). The command sequence is shown here. The Read SFDP command is terminated by driving Chip Select (\overline{CS}) high at any time during data output.

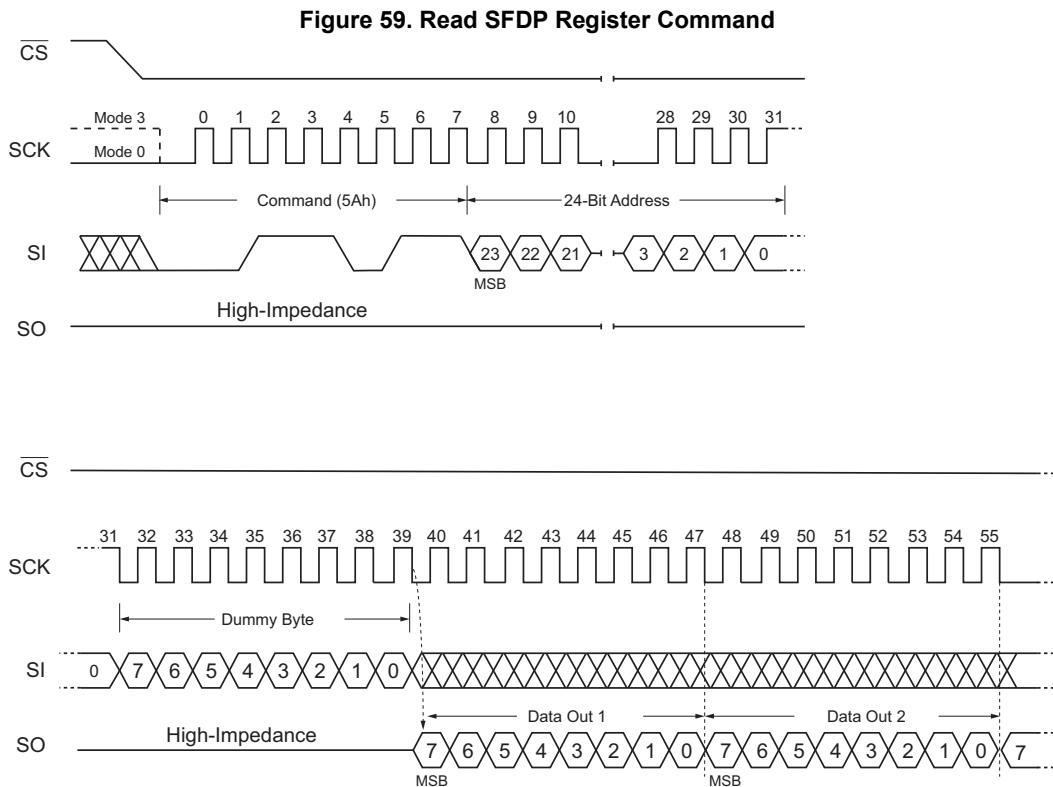

Table 15. SFDP Signature and Headers

Description	Comment	Address (h) Byte	Address (Bit)	Data (b) (Bit)	Data (h) (Byte)
SFDP Signature		00h	07:00	0101 0011	53h
		01h	15:08	0100 0110	46h
		02h	23:16	0100 0100	44h
		03h	31:24	0101 0110	50h
SFDP Minor Revision	Start from 00h	04h	07:00	0000 0110	06h
SFDP Major Revision	Start from 01h	05h	15:08	0000 0001	01h
Number of Parameters Headers	Start from 00h	06h	23:16	0000 0001	01h
Reserved	FFh	07h	31:24	1111 1111	FFh
JEDEC Parameter ID (LSB)	JEDEC Parameter ID (LSB) = 00h	08h	07:00	0000 0000	00h
Parameter Table Minor Revision	Start from 00h	09h	15:08	0000 0110	06h
Parameter Table Major Revision	Start from 01h	0Ah	23:16	0000 0001	01h
Parameter Table Length (double words)	How many DWORDs in the parameter table	0Bh	31:24	0001 0000	10h
Parameter Table Pointer	Address of Renesas Electronics parameter table	0Ch	07:00	0011 0000	30h
		0Dh	15:08	0000 0000	00h
		0Eh	23:16	0000 0000	00h
JEDEC Parameter ID (MSB)	JEDEC Parameter ID (MSB):FFh	0Fh	31:24	1111 1111	FFh
JEDEC Parameter ID (LSB)	Renesas Electronics Manufacturer ID	10h	07:00	0001 1111	1Fh
Parameter Table Minor Revision	Start from 00h	11h	15:08	0000 0000	00h
Parameter Table Major Revision	Start from 01h	12h	23:16	0000 0001	01h
Parameter Table Length (double words)	How many DWORDs in the parameter table	13h	31:24	0000 0010	02h
Parameter Table Pointer (PTP)	Address of Renesas Electronics parameter table	14h	07:00	1000 0000	80h
		15h	15:08	0000 0000	00h
		16h	23:16	0000 0000	00h
Reserved	FFh	17h	31:24	0000 0001	01h

Table 16. SFDP Parameters Table 1

Description	Comment	Address (h) Byte	Address (Bit)	Data (b) (Bit)	Data (h) (Byte)
Erase Granularity	01: 4 kB available 11: 4 kB not available	30h	01:00	01	E5h
Write Granularity	0: 1 byte 1: 64 bytes or larger		02	1	
Volatile Status Register Block Protect Bits	0: Nonvolatile status bit 1: Volatile status bit		03	0	
Volatile Status Register Write Enable Opcode	0: 50h Opcode to enable, if bit-3 = 1		04	0	
Reserved			07:05	111	
4 kB Erase Opcode	Opcode or FFh	31h	15:08	0010 0000	20h
Fast Dual Read Output (1-1-2)	0: Not supported 1: Supported	32h	16	1	F1h
Number of Address Bytes	00: 3 bytes only 01: 3 or 4 bytes 10: 4 bytes only 11: Reserved		18:17	00	
Double Transfer Rate (DTR) Clocking	0: Not supported 1: Supported		19	0	
Fast Dual I/O Read (1-2-2)	0: Not supported 1: Supported		20	1	
Fast Quad I/O Read (1-4-4)	0: Not supported 1: Supported		21	1	
Fast Quad Output Read (1-1-4)	0: Not supported 1: Supported		22	1	
Reserved	FFh		23	1	
Reserved	FFh				
Flash Memory Density		34h	07:00	1111 1111	FFh
		35h	15:08	1111 1111	FFh
		36h	23:16	1111 1111	FFh
		37h	31:24	0000 0011	03h
Fast Quad I/O (1-4-4) Number of dummy clocks	Number of dummy clocks	38h	04:00	00100	44h
Fast Quad I/O (1-4-4) Number of mode bits	Number of mode bits		07:05	010	
Fast Quad I/O (1-4-4) Read Opcode	Opcode or FFh	39h	15:08	1110 1011	EBh
Fast Quad Output (1-1-4) Number of dummy clocks	Number of dummy clocks	3Ah	20:16	01000	08h
Fast Quad Output (1-1-4) Number of mode bits	Number of mode bits		23:21	000	
Fast Quad Output (1-1-4) Read Opcode	Opcode or FFh	3Bh	31:24	0110 1011	6Bh
Fast Dual Output (1-1-2) Number of dummy clocks	Number of dummy clocks	3Ch	04:00	01000	08h
Fast Dual Output (1-1-2) Number of mode bits	Number of mode bits		07:05	000	
Fast Dual Output (1-1-2) Read Opcode	Opcode or FFh	3Dh	15:08	0011 1011	3Bh

Table 16. SFDP Parameters Table 1 (Continued)

Description	Comment	Address (h) Byte	Address (Bit)	Data (b) (Bit)	Data (h) (Byte)
Fast Dual I/O (1-2-2) Number of dummy clocks	Number of dummy clocks	3Eh	20:16	00000	80h
Fast Dual I/O (1-2-2) Number of mode bits	Number of mode bits		23:21	100	
Fast Dual I/O (1-2-2) Read Opcode	Opcode or FFh	3Fh	31:24	1011 1011	BBh
Fast Dual DPI (2-2-2)	0: Not supported 1: Supported	40h	0	0	FEh
Reserved	FFh		03:01	111	
Fast Quad QPI (4-4-4)	0: Not supported 1: Supported		04	1	
Reserved	FFh		07:05	111	
Reserved	FFh	41h	15:08	1111 1111	FFh
Reserved	FFh	42h	23:16	1111 1111	FFh
Reserved	FFh	43h	31:24	1111 1111	FFh
Reserved	FFh	44h	07:00	1111 1111	FFh
Reserved	FFh	45h	15:08	1111 1111	FFh
Fast Dual DPI (2-2-2) Number of dummy clocks	Number of dummy clocks	46h	20:16	0 0000	00h
Fast Dual DPI (2-2-2) Number of mode bits	Number of mode bits		23:21	000	
Fast Dual DPI(2-2-2) Read Opcode	Opcode or FFh	47h	31:24	1111 1111	FFh
Reserved	FFh	48h	07:00	1111 1111	FFh
Reserved	FFh	49h	15:08	1111 1111	FFh
Fast Quad QPI (4-4-4) Number of dummy clocks	Number of dummy clocks	4Ah	20:16	00010	42h
Fast Quadl QPI (4-4-4) Number of mode bits	Number of mode bits		23:21	010	
Fast Quad QPI (4-4-4) Read Opcode	Opcode or FFh	4Bh	31:24	1110 1011	EBh
Erase type-1 Size	4 kB = 2 ⁰ Ch, 32 kB = 2 ⁰ Fh, 64 kB = 2 ¹ 0h; (2 ^N byte)	4Ch	07:00	0000 1100	0Ch
Erase type-1 Opcode	Opcode or FFh	4Dh	15:08	0010 0000	20h
Erase type-2 Size	4 kB = 2 ⁰ Ch, 32 kB = 2 ⁰ Fh, 64 kB = 2 ¹ 0h; (2 ^N byte)	4Eh	23:16	0000 1111	0Fh
Erase type-2 Opcode	Opcode or FFh	4Fh	31:24	0101 0010	52h
Erase Type-3 Size	4 kB = 2 ⁰ Ch, 32 kB = 2 ⁰ Fh, 64 kB = 2 ¹ 0h; (2 ^N byte)	50h	07:00	0001 0000	10h
Erase Type-3 Opcode	Opcode or FFh	51h	15:08	1101 1000	D8h
Erase Type-4 Size	4 kB = 2 ⁰ Ch, 32 kB = 2 ⁰ Fh, 64 kB = 2 ¹ 0h; (2 ^N byte)	52h	23:16	0000 0000	00h
Erase Type-4 Opcode	Opcode or FFh	53h	31:24	1111 1111	FFh

Table 16. SFDP Parameters Table 1 (Continued)

Description	Comment	Address (h) Byte	Address (Bit)	Data (b) (Bit)	Data (h) (Byte)
Erase Maximum/Typical Ratio	Maximum = 2 * (COUNT + 1) * Typical	54h 55h 56h 57h	03:00	0011	33h 62h D5h 00h
Erase type-1 Typical time	Count or 00h		08:04	0 0011	
Erase type-1 Typical units	00b: 1 ms 01b: 16 ms 10b: 128 ms 11b: 1 sec		10:09	01	
Erase type-2 Typical time	Count or 00h		15:11	0110 0	
Erase type-2 Typical units	00b: 1 ms 01b: 16 ms 10b: 128 ms 11b: 1 sec		17:16	01	
Erase type-3 Typical time	Count or 00h		22:18	101 01	
Erase type-3 Typical units	00b: 1 ms 01b: 16 ms 10b: 128 ms 11b: 1 sec		24:23	01	
Erase type-4 Typical time	Count or 00h		29:25	00 000	
Erase type-4 Typical units	00b: 1 ms 01b: 16 ms 10b: 128 ms 11b: 1 sec		31:30	00	
Program Maximum/Typical Ratio	Maximum = 2 * (COUNT + 1) * Typical		58h	03:00	
Page Size	2*N bytes	07:04		1000	
Program Page Typical time	Count or 00h	59h 5Ah 5Bh	12:08	0 1001	29h 01h C7h
Program Page Typical units	0: 8 μs, 1: 64 μs		13	1	
Program Byte Typical time, 1st byte	Count or 00h		17:14	01 00	
Program Byte Typical units, 1st byte	0: 1 μs, 1: 8 μs		18	0	
Program Additional Byte Typical time	Count or 00h		22:19	000 0	
Program Additional Byte Typical units	0: 1 μs, 1: 8 μs		23	0	
Erase Chip Typical time	Count or 00h		28:24	0 0111	
Erase Chip Typical units	00b: 16 ms 01b: 256 ms 10b: 4 sec 11b: 64 sec		30:29	10	
Reserved	1h		31	1	
Prohibited Op during Program Suspend	see Datasheet		5Ch	03:00	
Prohibited Op during Erase Suspend	see Datasheet	07:04		1110	

Table 16. SFDP Parameters Table 1 (Continued)

Description	Comment	Address (h) Byte	Address (Bit)	Data (b) (Bit)	Data (h) (Byte)
Reserved	1h	5Dh 5Eh 5Fh	08	1	A1h 07h 3Dh
Program Resume to Suspend time	Count of 64us		12:09	0 000	
Program Suspend Maximum time	Count or 00h		17:13	11 101	
Program Suspend Maximum units	00b: 128 ns, 01b: 1 μs, 10b: 8 μs, 11b: 64 μs		19:18	01	
Erase Resume to Suspend time	Count of 64 μs		23:20	0000	
Erase Suspend Maximum time	Count or 00h		28:24	1 1101	
Erase Suspend Maximum units	00b: 128 ns, 01b: 1 μs, 10b: 8 μs, 11b: 64 μs		30:29	01	
Suspend / Resume supported	0: Program and Erase suspend supported 1: not supported		31	0	
Program Resume Opcode	Opcode or FFh	60h	7:0	0111 1010	7Ah
Program Suspend Opcode	Opcode or FFh	61h	15:8	0111 0101	75h
Resume Opcode	Opcode or FFh	62h	23:16	0111 1010	7Ah
Suspend Opcode	Opcode or FFh	63h	31:24	0111 0101	75h
Reserved	11b	64h	01:00	11	F7h
Status Register Busy Polling	xxxx1b: Opcode = 05h, bit-0 = 1 Busy, xxxx1xb: Opcode = 70h, bit-7 = 0 Busy, Others: reserved		07:02	1111 01	
Exit Deep Power-down time	Count or 00h	65h 66h 67h	12:08	0 0010	A2h D5h 5Ch
Exit Deep Power-down units	00b: 128 ns, 01b: 1 μs, 10b: 8 μs, 11b: 64 μs		14:13	01	
Exit Deep Power-down Opcode	Opcode or FFh		22:15	101 0101 1	
Enter Deep Power-down Opcode	Opcode or FFh		30:23	101 1100 1	
Deep Power-down Supported	0: Deep Power-down supported 1: Not supported		31	0	

Table 16. SFDP Parameters Table 1 (Continued)

Description	Comment	Address (h) Byte	Address (Bit)	Data (b) (Bit)	Data (h) (Byte)
Disable 4-4-4 Read Mode		68h 69h 6Ah	03:00	1001	19h F6h 1Ch
Enable 4-4-4 Read Mode			08:04	0 0001	
Fast Quad I/O Continuous (0-4-4) supported	0: not supported, 1: Quad I/O 0-4-4 supported		09	1	
Fast Quad I/O Continuous (0-4-4) Exit			15:10	1111 01	
Fast Quad I/O Continuous (0-4-4) Enter			19:16	1100	
Quad Enable Requirements (QER)			22:20	001	
HOLD or RESET Disable	0: not supported, 1: use Configuration Register bit-4		23	0	
Reserved	FFh	6Bh	31:24	1111 1111	FFh
Status Register Opcode		6Ch	06:00	110 1000	E8h
Reserved	1h		07	1	
Soft Reset Opcodes		6Dh	13:08	01 0000	10h C0h
4-Byte Address Exit		6Eh	23:14	1100 0000 00	
4-Byte Address Enter		6Fh	31:24	1000 0000	80h

Table 17. SFDP Parameters Table 2

Description	Comment	Address (h) Byte	Address (Bit)	Data (b) (Bit)	Data (h) (Byte)
VCC Minimum Voltage	1650h: 1.65V 1700h: 1.70V 2300h: 2.30V 2500h: 2.50V 2700h: 2.70V	80h 81h	15:0	0000 0000 0001 0111	00h 17h
VCC Maximum Voltage	1950h: 1.95V 3600h: 3.60V 4000h: 4.00V 4400h: 4.40V	82h 83h	31:16	0000 0000 0010 0000	00h 20h
Array Protection Method	10b: Use non-volatile status register	84h 85h	01:00	00	00h 00h
Power up Protection default	0: Power up unprotected 1: Power up protected		02	0	
Protection Disable Opcodes	011b: Use status register		05:03	00 0	
Protection Enable Opcodes	011b: Use status register		08:06	0 00	
Protection Read Opcodes	011b: Use status register		11:09	000	
Protection Register Erase Opcode	00b: Not supported 01b: Opcodes 3Dh, 2Ah, 7Fh, FCh		13:12	00	
Protection Register Program Opcode	00b: Not supported 01b: Opcodes 3Dh, 2Ah, 7Fh, FCh		15:14	00	
Reserved	FFh	86h	23:16	1111 1111	FFh
Reserved	FFh	87h	31:24	1111 1111	FFh
Reserved	FFh	88h - FFh			Reserved

8.36 Enter Secured OTP (B1h)

The Enter Secured OTP command is for entering the additional 4 kbit secured OTP mode. This additional mode is independent from the main array, which may be used to store unique serial number for system identifier. After entering the Secured OTP mode, the standard read or program procedure can be used to read or write data. The Secured OTP data cannot be updated again once it is locked down.

Please note that Write Status Register-1, Write Status Register-2 and Write Security Register commands are not acceptable during the access of secure OTP region. Once security OTP is locked down, only commands related with read are valid. The Enter Secured OTP command sequence is shown in Figure 60.

Figure 60. Enter Secured OTP Command for SPI Mode (left) and QPI Mode (right)

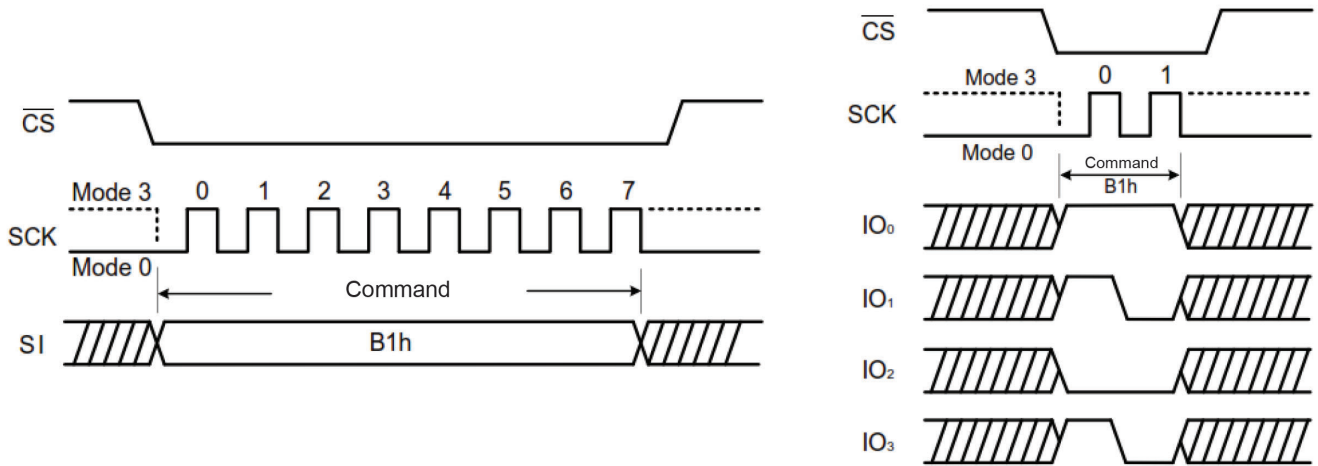

8.37 Exit Secured OTP (C1h)

The Exit Secured OTP command is for exiting the additional 4 kbit secured OTP mode. (See Figure 61.)

Figure 61. Exit Secured OTP command for SPI Mode (left) and QPI Mode (right)

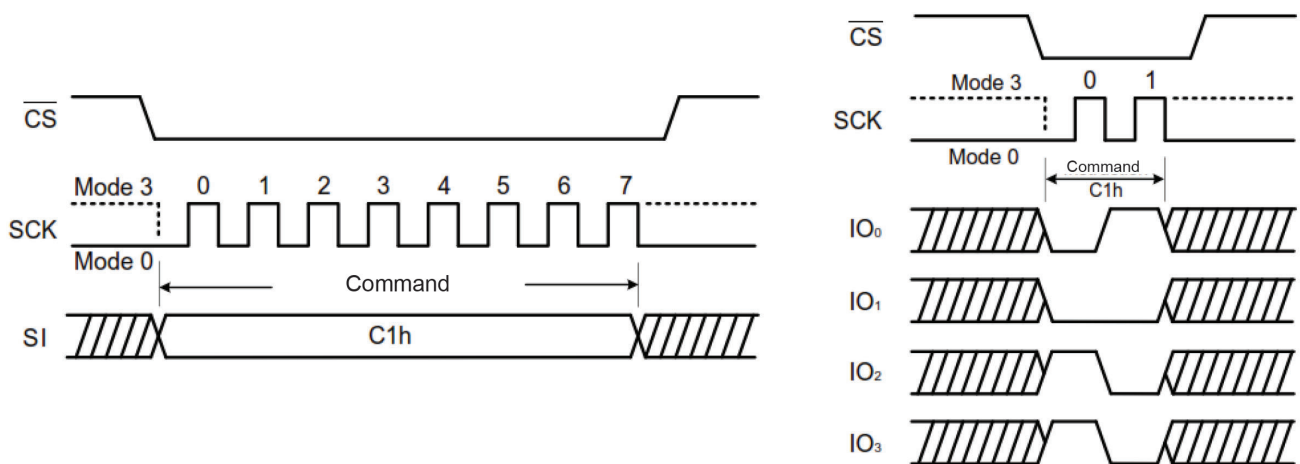

8.38 Read Security Register (2Bh)

The Read Security Register can read the value of Security Register bits at any time (even in program/erase/write status register-1 and write status register-2 condition) and continuously. Bits 0 and 1 of this register are described below. All other bits of the register are reserved.

Secured OTP Indicator bit. The Secured OTP indicator bit shows the chip is locked by factory before or not. When it is 0, it indicates a non-factory lock, a 1 indicates a factory lock.

Lock-down Secured OTP (LDSO) bit. By executing the Write Security Register command, the LDSO bit may be set to 1 for customer lock down purposes. However, once the bit is set to 1 (locked down), the LDSO bit and the 4 kbit Secured OTP area cannot be updated any more. While it is in 4 kbit Secured OTP mode, array access is not allowed to write.

Table 18. Security Register Definition

Bit 7	Bit 6	Bit 5	Bit 4	Bit 3	Bit 2	Bit 1	Bit 0
x	x	x	x	x	x	LDSO (indicate if lock-down)	Secured OTP indicator bit
Reserved	Reserved	Reserved	Reserved	Reserved	Reserved	0 = not lock-down 1 = lock-down (cannot program/erase OTP)	0 = non factory lock 1 = factory lock
Volatile bit	Volatile bit	Volatile bit	Volatile bit	Volatile bit	Volatile bit	Non-Volatile bit	Non-Volatile bit

Figure 62. Read Security Register Command (SPI Mode)

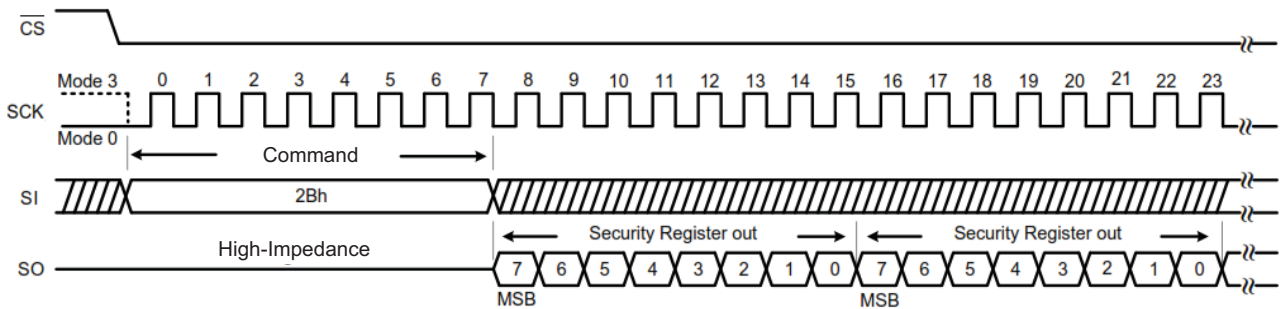
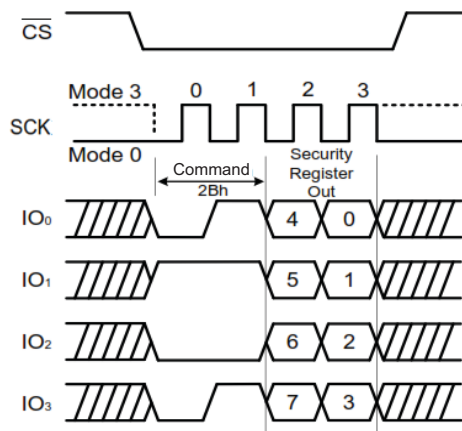

Figure 63. Read Security Register Command (QPI Mode)



8.39 Write Security Register (2Fh)

The Write Security Register command is for change the state of the bits in the Security Register. Unlike the Write Status Register command, the Write Enable command is not required before executing the Write Security Register command. The command may change the value of bit 1 (LDSO bit) for a customer to lock down the 4 kbit Secured OTP area. Once the LDSO bit is set to 1, the Secured OTP area cannot be updated any more.

The \overline{CS} must go high exactly at the boundary; otherwise, the command is not executed.

Figure 64. Write Security Register Command for SPI Mode (left) and QPI Mode (right)

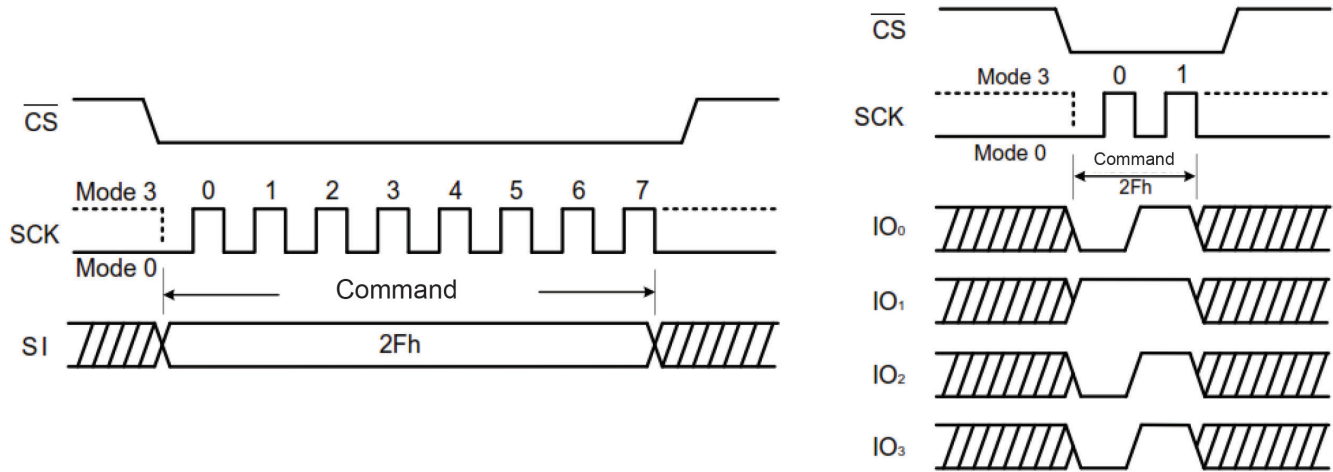

8.40 4 kbit Secured OTP

The AT25QL641 provides a 4 kbit one-time-program area for setting a unique serial number which can be set by either the factory or the customer. Security register bit 0 indicates whether the chip is locked by factory or not.

The 4 kbit OTP space is accessed using the B1h command as described above. After the OTP value has been programmed, the C1h command is used to exit from the secured OTP space.

The secure OTP space is divided into a 128-bit electronic serial number, and 3968 bits is user-defined data as shown in Table 19.

Note. Once the OTP space is locked down, either by the factory or the customer, it cannot be changed any more. While in 4 kbit secured OTP mode, array access is not allowed to write.

Table 19. Secure OTP Address Space

Address Range	Size	Standard	Customer Lock
000000 ~ 00000F	128-bit	ESN (Electrical Serial Number)	Determined by customer
000010 ~ 0001FF	3968-bit	N/A	

9. Electrical Characteristics

Table 20. Absolute Maximum Ratings^[1]

Parameter	Symbol	Conditions	Value	Units
Supply Voltage	VCC		-0.6 to VCC+0.4	V
Voltage Applied to any pin	VIO	Relative to Ground	-0.6 to VCC +0.4	V
Transient Voltage on any pin	VIOT	<20nS Transient Relative to Ground	-1.0 V to VCC +1.0 V	V
Storage temperature	TSTG		-65 to +150	°C
Lead temperature	TLEAD		See Note ^[2]	°C
Electrostatic discharge voltage	VESD	Human Body Model ^[3]	-2000 to +2000	V

1. Stresses beyond those listed under Absolute Maximum Ratings may cause permanent damage to the device. The Absolute Maximum Ratings are stress ratings only and functional operation of the device at these or any other conditions beyond those indicated in the operational sections of this specification is not implied. Exposure to absolute maximum rating conditions for extended periods may affect device reliability. Voltage extremes referenced in the Absolute Maximum Ratings are intended to accommodate short duration undershoot/overshoot conditions and does not imply or guarantee functional device operation at these levels for any extended period of time.
2. Compliant with JEDEC Standard J-STD-20C for small body Sn-Pb or Pb-free (Green) assembly and the European directive on restrictions on hazardous substances (RoHS) 2002/95/EU.
3. JEDEC Std JESD22-A114A (C1 = 100 pF, R1 = 1500Ω, R2 = 500Ω).

Table 21. Operating Ranges

Parameter	Symbols	Conditions	Min	Max	Units
Supply Voltage	VCC	f _R = 133 MHz (Single/Dual/Quad SPI) f _R = 50 MHz (Read Data 03h)	1.7	2.0	V
Ambient Operating Temperature	T _A	Industrial	-40	+85	°C

Table 22. Endurance and Data Retention

Parameter	Conditions	Min	Max	Units
Erase/Program Cycles	4 kB Block, 32/64 kB block, or full chip	100,000		Cycles
Data Retention	Full Temperature Range		20	Years

Table 23. Power-up Timing and Write Inhibit Threshold

Parameter	Symbol ^[1]	Min	Max	Units
VCC (min) to \overline{CS} low	t _{VSL}	10		μs
Time Delay before Write Command	t _{PUW}	1	10	ms
Write Inhibit Threshold Voltage	VWI	1.0	1.4	V

1. These parameters are characterized at -10°C and +85°C only

Figure 65. Power-Up Timing and Voltage Levels

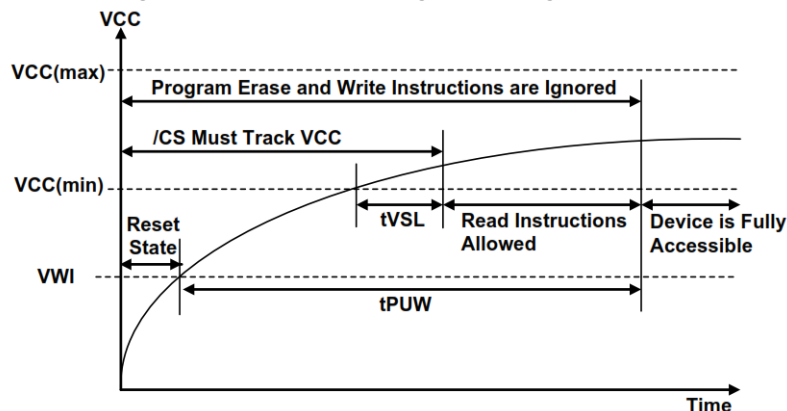

9.1 DC Electrical Characteristics

Table 24. DC Electrical Characteristics

Parameter	Symbol	Condition	Min	Typ	Max	Units
Input Capacitance ^[1]	C _{IN}	V _{IN} = 0V			6	pF
Output Capacitance ⁽¹⁾	C _{OUT}	V _{OUT} = 0V			8	pF
Input Leakage	I _{LI}				±2	μA
Output Leakage	I _{LO}				±2	μA
Standby Current	I _{CC1}	$\overline{CS} = VCC$ V _{IN} = GND or VCC		10	50	μA
Power-Down Current	I _{CC2}	$\overline{CS} = VCC$ V _{IN} = GND or VCC		2	20	μA
Current Read Data Dual/Quad 1 MHz ^[2]	I _{CC3}	C = 0.1 VCC / 0.9 VCC IO = Open			7	mA
Current Read Data Dual/Quad 50 MHz ⁽²⁾	I _{CC3}	C = 0.1 VCC / 0.9 VCC IO = Open			15	mA
Current Read Data Dual/Quad 80 MHz ⁽²⁾	I _{CC3}	C = 0.1 VCC / 0.9 VCC IO = Open			18	mA
Current Read Data Dual/Quad 104 MHz ⁽²⁾	I _{CC3}	C = 0.1 VCC / 0.9 VCC IO = Open			20	mA
Current Read Data Dual/Quad 133 MHz ⁽²⁾	I _{CC3}	C = 0.1 VCC / 0.9 VCC IO = Open			27	mA
Current Write Status Register	I _{CC4}	$\overline{CS} = VCC$		10	20	mA
Current Page Program	I _{CC5}	$\overline{CS} = VCC$		15	25	mA
Current Block Erase	I _{CC6}	$\overline{CS} = VCC$		15	25	mA
Current Chip Erase	I _{CC7}	$\overline{CS} = VCC$		15	25	mA

1. Tested on sample basis and specified through design and characterization data, TA = 25C, VCC = 1.8V.
2. Checked board pattern.

9.2 AC Measurement Conditions

Table 25. AC Measurement Conditions

Parameter	Symbol	Min	Max	Units
Load Capacitance	C _L		30	pF
Input Rise and Fall Times	t _R , t _F		5	ns
Input Pulse Voltages	V _{IN}	0.2 VCC to 0.8 VCC		V
Input Timing Reference Voltages	I _N	0.3 VCC to 0.7 VCC		V
Output Timing Reference Voltages	O _{UT}	0.5 VCC to 0.5 VCC		V

Figure 66. AC Measurement I/O Waveform

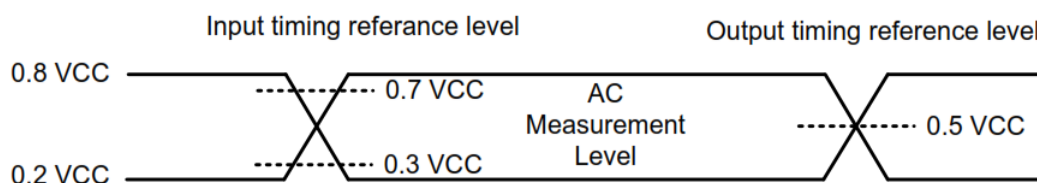

Input pulse rise and fall times are < 5ns

9.3 AC Electrical Characteristics

Table 26. AC Electrical Characteristics

Parameter ^[1]	Symbol	Alt	Min	Typ	Max	Unit
Clock frequency for all commands, except Read Data and Fast Read Data in SPI mode (03h, 0Bh) 1.7 V - 2.0 V VCC and industrial temperature	f _R	f _c	D.C.		133	MHz
Clock freq. Fast Read Data command in SPI mode (0Bh)	f _R		D.C.		104	MHz
Clock freq. Read Data command in SPI mode (03h)	f _R		D.C.		50	MHz
Clock High, Low Time except Read Data (03h)	t _{CLH} , t _{CLL} ^[2]		3.5			ns
Clock High, Low Time for Read Data (03h)	t _{CRLH}		8			ns
Clock Rise Time peak-to-peak	t _{CLCH} ^[3]		0.1			V/ns
Clock Fall Time peak-to-peak	t _{CHCL} ⁽³⁾		0.1			V/ns
\overline{CS} Active Setup Time relative to Clock	t _{SLCH}	t _{CSS}	5			ns
\overline{CS} Not Active Hold Time relative to Clock	t _{CHSL}		5			ns
Data In Setup Time	t _{DVCH}	t _{DSU}	2			ns
Data In Hold Time	t _{CHDX}	t _{DH}	3			ns
\overline{CS} Active Hold Time relative to Clock	t _{CHSH}		5			ns
\overline{CS} Not Active Setup Time relative to Clock	t _{CHSH}		5			ns
\overline{CS} Deselect Time (for Read commands/Write, Erase and Program commands)	t _{SHSL}	t _{CSH}	100			ns
Output Disable Time	t _{SHQZ} ⁽³⁾	t _{DIS}			7	ns
Clock Low to Output Valid	t _{CLQV}	t _{V1}			6	ns
Clock Low to Output Valid (Except Main Read) ^[4]	t _{CLQV}	t _{V2}			7	ns
Output Hold Time	t _{CLQX}	t _{HO}	1.5			ns
\overline{HOLD} Active Setup Time relative to Clock	t _{HLCH}		5			ns
\overline{HOLD} Active Hold Time relative to Clock	t _{CHHH}		5			ns
\overline{HOLD} Not Active Setup Time relative to Clock	t _{HHCH}		5			ns
\overline{HOLD} Not Active Hold Time relative to Clock	t _{CHHL}		5			ns
\overline{HOLD} to Output Low-Z	t _{HHQX} ⁽³⁾	t _{LZ}			7	ns
\overline{HOLD} to Output High-Z	t _{HLQZ} ⁽³⁾	t _{HZ}			12	ns
Write Protect Setup Time Before \overline{CS} Low	t _{WHSL} ^[5]		20			ns
Write Protect Setup Time After \overline{CS} High	t _{SHWL} ⁽⁵⁾		100			ns
\overline{CS} High to Power-Down Mode	t _{DP} ⁽³⁾				3	μs
\overline{CS} High to Standby Mode without Electronic Signature Read	t _{RES1} ⁽³⁾				3	μs
\overline{CS} High to Standby Mode with Electronic Signature Read	t _{RES2} ⁽³⁾				1.8	μs
\overline{CS} High to next Command after Suspend	t _{SUS} ⁽³⁾				30	μs
\overline{CS} High to next Command after Reset	t _{RST} ⁽³⁾				30	μs

Table 26. AC Electrical Characteristics (Continued)

Parameter ^[1]	Symbol	Alt	Min	Typ	Max	Unit
Write Status Register Time	tw			5	15	ms
Byte Program Time	tBP			5	150	μs
Page Program Time	tPP			0.6	5	ms
Block Erase Time (4 kB)	tSE			0.06	0.4	s
Block Erase Time (32 kB)	tBE1			0.2	1.5	s
Block Erase Time (64 kB)	tBE2			0.35	2	s
Chip Erase Time	tCE			60	150	s

1. Commercial temperature only applies to Fast Read (FR). Industrial temperature applies to all other parameters.
2. Clock high + Clock low must be less than or equal to 1/fc.
3. Value guaranteed by design and/or characterization, not 100% tested in production.
4. Contains: Read Status Register-1, 2/ Read Manufacturer/Device ID, Dual, Quad/ Read JEDEC ID/ Read Security Register/ Read Serial Flash Discovery Parameter.
5. Only applicable as a constraint for a Write Status Register command when Sector Protect Bit is set to 1.

9.4 Input Timing

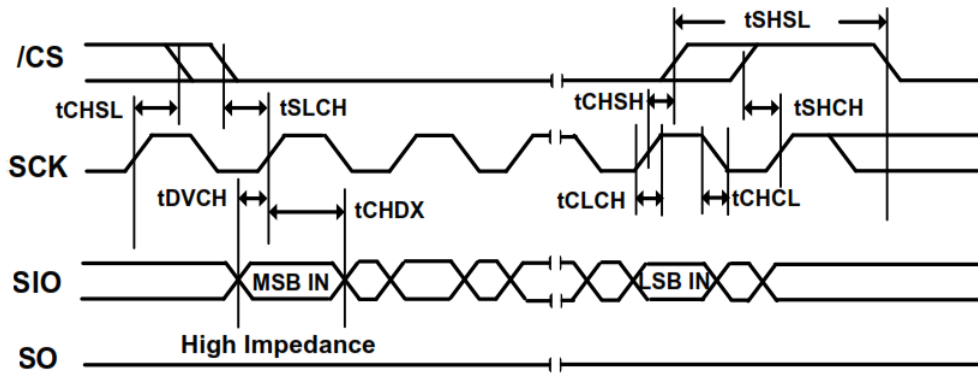

9.5 Output Timing

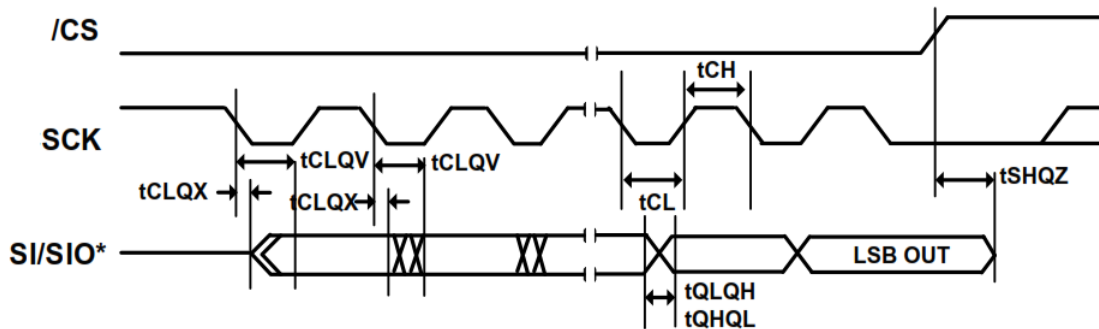

* SIO IS AN OUTPUT ONLY FOR THE FAST READ DUAL OUTPUT INSTRUCTION (3Bh)

9.6 Hold Timing

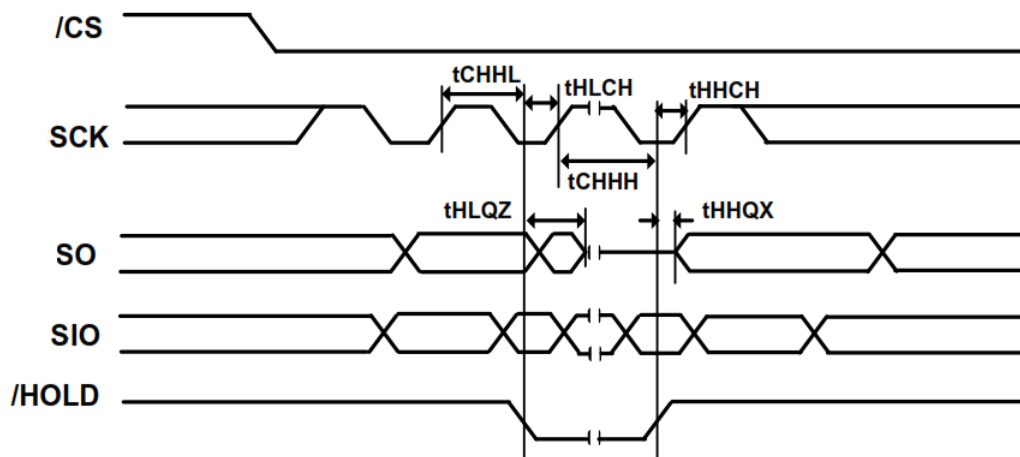

10. Ordering Information

10.1 Ordering Code Detail

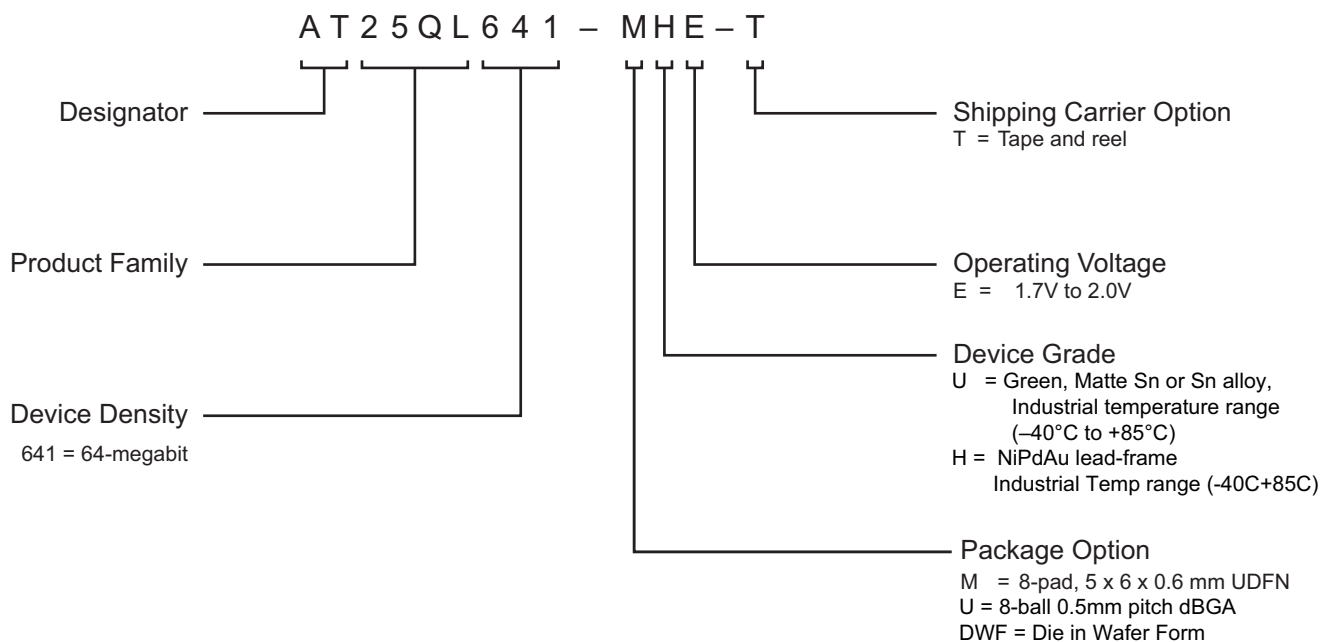

Ordering Code ^{[1][2]}	Package	Lead Finish	Operating Voltage	Max. Freq. (MHz)	Operation Range
AT25QL641-MHE-T	8MA1	NiPdAu	1.7 V - 2.0 V	133 MHz	-40 °C to 85 °C (Industrial Temperature Range)
AT25QL641-MHE-T	8S4	SnAgCu			
AT25QL641-UUE-T	8-WLCSP				

1. The AT25QL641 is shipped with the QE bit set to 1 enabling the Quad / QPI mode.
2. The shipping carrier option code is not marked on the devices.

Package Type	
8MA1	8-pad (5 x 6 x 0.6 mm body), Thermally Enhanced Plastic Ultra-Thin Dual Flat No-lead (UDFN)
8-WLCSP	8-ball, 0.5mm pitch, die Ball Grid Array (dBGA)

11. Packaging Information

11.1 8MA1 – UDFN

COMMON DIMENSIONS
(Unit of Measure = mm)

SYMBOL	MIN	NOM	MAX	NOTE
A	0.45	0.55	0.60	
A1	0.00	0.02	0.05	
b	0.35	0.40	0.48	
C	0.152 REF			
D	4.90	5.00	5.10	
D2	3.80	4.00	4.20	
E	5.90	6.00	6.10	
E2	3.20	3.40	3.60	
e	1.27			
L	0.50	0.60	0.75	
y	0.00	-	0.08	
K	0.20	-	-	

Notes: 1. This package conforms to JEDEC reference MO-229, Saw Singulation.
2. The terminal #1 ID is a Laser-marked Feature.

4/15/08

	TITLE	GPC	DRAWING NO.	REV.
	8MA1, 8-pad (5 x 6 x 0.6 mm Body), Thermally Enhanced Plastic Ultra Thin Dual Flat No Lead Package (UDFN)	YFG	8MA1	D

11.2 8-WLCSP — die Ball Grid Array

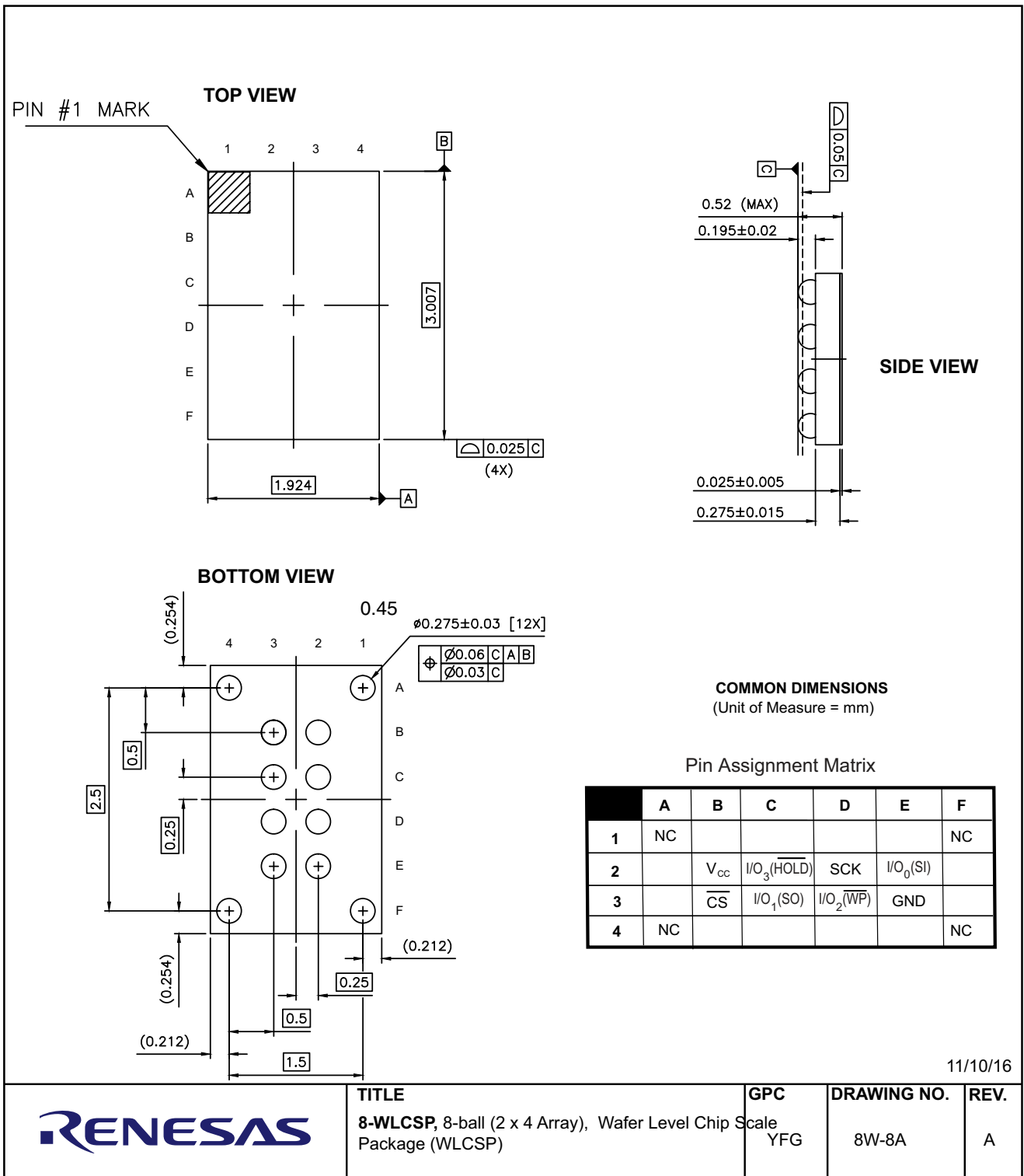

TITLE
8-WLCSP, 8-ball (2 x 4 Array), Wafer Level Chip Scale Package (WLCSP)

GPC
Scale
YFG

DRAWING NO.
8W-8A

REV.
A

12. Revision History

Revision	Date	Change Description
A	12/2016	Initial release of AT25QL641 datasheet.
B	02/2017	Updated Note 1 on Table 8.1.
C	05/2017	Updated Table 1-1 (\overline{WP} pin description). Updated 5.1 (Write Protect Features). Updated Tables 6-1 and 6-2. Restored Sector and Block Protect descriptions. Restored Status Register Memory Protection tables (Tables 6-3 and 6-4). Added clarification to Write Status Register (01h) description. Updated document status from Advanced to Complete. Added Errata 11.1.
D	11/2017	Removed references to 133 MHz option. Removed RESET option. Removed 18-WLCSP and 24-ball BGA package options. Removed references to ACC feature.
E	10/2018	<p>Added 133 MHz frequency option to document.</p> <p>Updated maximum frequency to 133 MHz on page 1.</p> <p>Updated frequencies in Section 1.</p> <p>Updated formatting of all tables in document.</p> <p>Updated Word Read Quad I/O command diagram in Figure 7-50.</p> <p>Updated frequency in Burst Read with Wrap command in Figure 7-54.</p> <p>Updated tables in Section 7.33, Set Read Parameters (C0h).</p> <p>Updated AC Electrical Characteristics in Table 8-7 with 133 MHz option.</p> <p>Clarified frequency and timing parameters for the 03h and 0Bh commands in Table 8-7.</p> <p>Updated ordering code table in Section 9.1.</p> <p>Removed DWF package.</p> <p>Updated maximum continuous data transfer rate from 52 Mbps to 66 Mbps on page 1.</p>
F	03/2022	<p>Applied new corporate template to document.</p> <p>Added physical block size information to Features list and to Section 1, Introduction.</p> <p>Added the following text to Section 7.21, Erase / Program Suspend (75h): "A read operation from an 8-Mbit area (referred to as a physical block) that includes a suspended area might provide unreliable data. For the definition of the physical block and for the techniques to ensure high data integrity, see application note AN-500."</p> <p>Removed the 208-mil SOIC package option in Section 10 and Section 11.</p> <p>Added the following note to the description of the 75h command.</p> <p>A read operation from a 8-Mbit area (referred to as a physical block) which includes a suspended area might provide unreliable data. For the definition of the physical block and for the techniques to ensure high data integrity, see application note AN-500.</p> <p>Changed "AT25SL128A-SUE-T" to "AT25SL128A-MHE-T" in Section 10.</p> <p>Removed the "S" from Package Options in Section 10.</p> <p>Removed "AT25SL128A-SUE-T" from Ordering Code in Section 10.</p> <p>Removed "8S4" from Package Type in Section 10.</p>

12.1 Errata:

1. If Status Register-2 CMP bit is 0, and Status Register-1 bits {SEC,TB,BP2,BP1,BP} are {1,0,0,0,1}, address 7FF000h-7FFFFFFh *is protected* from any Program or Erase commands. However, this setting does *not* protect the rest of Sector 127 or the rest of Block 255 from 64 kbit or 32 kbit Block Erase commands. If a 64 kbit Block Erase Command is issued to Sector 127, address 7F0000h-7FEFFFh *is* be erased. If a 32 kbit Block Erase Command is issued to Block 255, address 7F8000h-7FEFFFh *is* be erased.

Workaround: If this protection bit combination is used and the behavior described in Note 3 is required, avoid using 64 kbit or 32kbit Block Erase commands for this specific memory region.

2. If Status Register-2 CMP bit is 1, and Status Register-1 bits {SEC,TB,BP2,BP1,BP} are {1,1,0,0,1}, address 001000h-7FFFFFFh *is protected* from any Program or Erase commands. However, this setting does *not* protect the rest of Sector 0 or the rest of Block 0 from 64 kbit or 32kbit Block Erase commands. If a 64 kbit Block Erase Command is issued to Sector 0, address 000000h-000FFFh *is* be erased. If a 32 kbit Block Erase Command is issued to Block 0, address 000000h-000FFFh *is* be erased.

Workaround: If this protection bit combination is used and the behavior described in Note 3 is required, avoid using 64 kbit or 32 kbit Block Erase commands for this specific memory region.

IMPORTANT NOTICE AND DISCLAIMER

RENESAS ELECTRONICS CORPORATION AND ITS SUBSIDIARIES (“RENESAS”) PROVIDES TECHNICAL SPECIFICATIONS AND RELIABILITY DATA (INCLUDING DATASHEETS), DESIGN RESOURCES (INCLUDING REFERENCE DESIGNS), APPLICATION OR OTHER DESIGN ADVICE, WEB TOOLS, SAFETY INFORMATION, AND OTHER RESOURCES “AS IS” AND WITH ALL FAULTS, AND DISCLAIMS ALL WARRANTIES, EXPRESS OR IMPLIED, INCLUDING, WITHOUT LIMITATION, ANY IMPLIED WARRANTIES OF MERCHANTABILITY, FITNESS FOR A PARTICULAR PURPOSE, OR NON-INFRINGEMENT OF THIRD PARTY INTELLECTUAL PROPERTY RIGHTS.

These resources are intended for developers skilled in the art designing with Renesas products. You are solely responsible for (1) selecting the appropriate products for your application, (2) designing, validating, and testing your application, and (3) ensuring your application meets applicable standards, and any other safety, security, or other requirements. These resources are subject to change without notice. Renesas grants you permission to use these resources only for development of an application that uses Renesas products. Other reproduction or use of these resources is strictly prohibited. No license is granted to any other Renesas intellectual property or to any third party intellectual property. Renesas disclaims responsibility for, and you will fully indemnify Renesas and its representatives against, any claims, damages, costs, losses, or liabilities arising out of your use of these resources. Renesas' products are provided only subject to Renesas' Terms and Conditions of Sale or other applicable terms agreed to in writing. No use of any Renesas resources expands or otherwise alters any applicable warranties or warranty disclaimers for these products.

(Rev.1.0 Mar 2020)

Corporate Headquarters

TOYOSU FORESIA, 3-2-24 Toyosu,
Koto-ku, Tokyo 135-0061, Japan
www.renesas.com

Contact Information

For further information on a product, technology, the most up-to-date version of a document, or your nearest sales office, please visit:
www.renesas.com/contact/

Trademarks

Renesas and the Renesas logo are trademarks of Renesas Electronics Corporation. All trademarks and registered trademarks are the property of their respective owners.