

# SPECIFICATIONS

PARAMETERS	VALUES	UNITS
RATED VOLTAGE	18	Vp-p
OPERATING VOLTAGE RANGE	1 ~ 60	Vp-p
RATED CURRENT (MAX)	10	mA
CAPACITANCE	120,000 ± 30%	pF
MINIMUM SPL @ 10 CM	105	dBA
RESONANT FREQUENCY	1,000 ± 200	Hz
OPERATING TEMPERATURE	-40 ~ +105	°C
STORAGE TEMPERATURE	-40 ~ +105	°C
HOUSING MATERIAL	PA6	-
TERMINAL MATERIAL	Sn PLATED COPPER	-
WEIGHT	14	grams

THIS DOCUMENT CONTAINS DATA PROPRIETARY TO PROJECTS UNLIMITED, INC. ANY USE OR REPRODUCTION, IN ANY FORM, WITHOUT PRIOR WRITTEN PERMISSION OF PROJECTS UNLIMITED, INC. IS PROHIBITED.  
©2003, Projects Unlimited Inc.

# REVISION HISTORY

LTR	DESCRIPTION	DATE	APPROVED
-	RELEASED FROM ENGINEERING	11/22/2006	
A	REVISED TO INVENTOR 3-D DRAWING TEMPLATE	10/6/2008	B.R.
B	ADDED RATED CURRENT (MAX)	12/17/2010	B.R.
C	UPDATE ROHS AND ADD MANUAL SOLDER NOTE	1/25/2019	M.L.

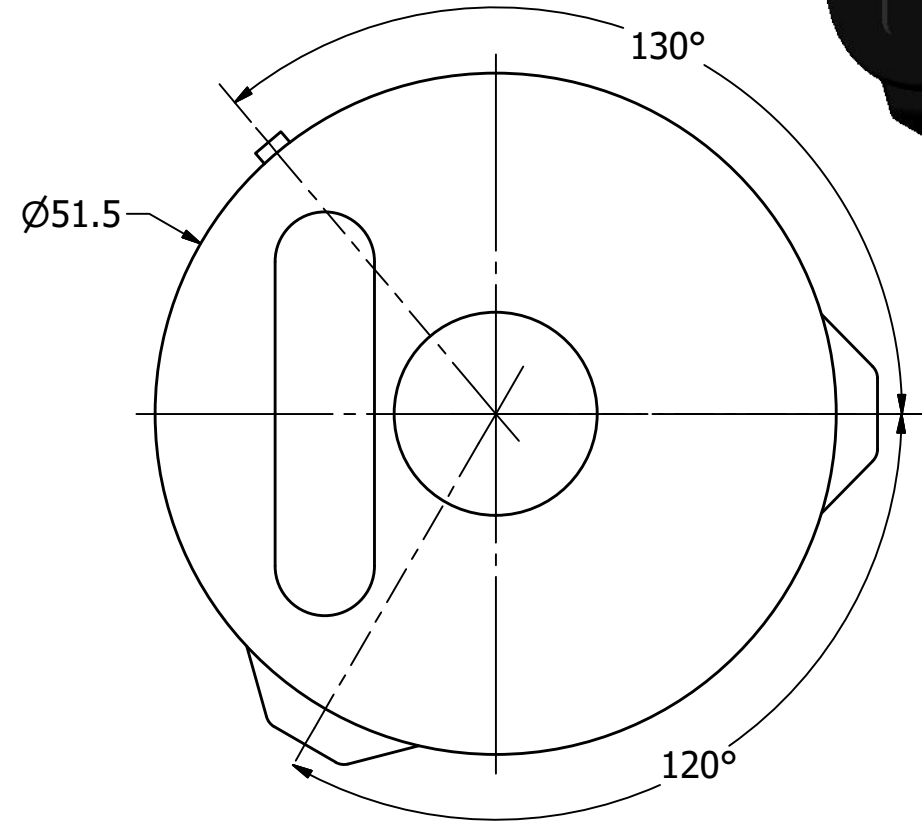
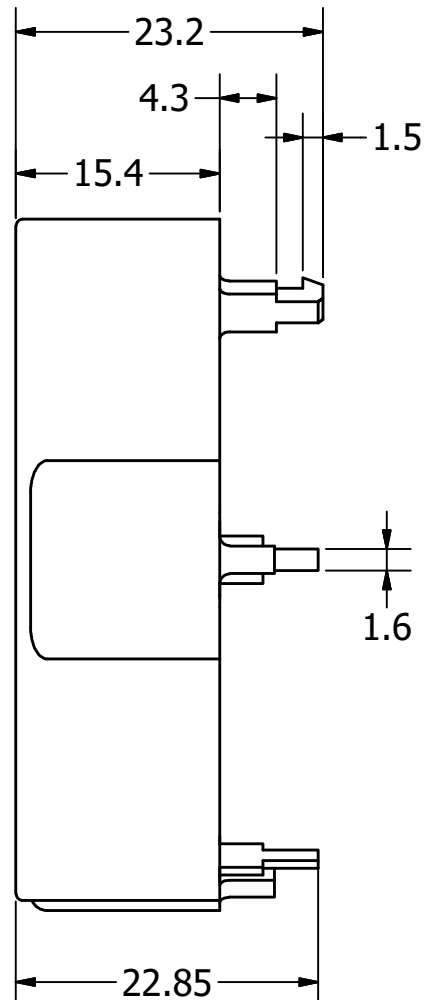
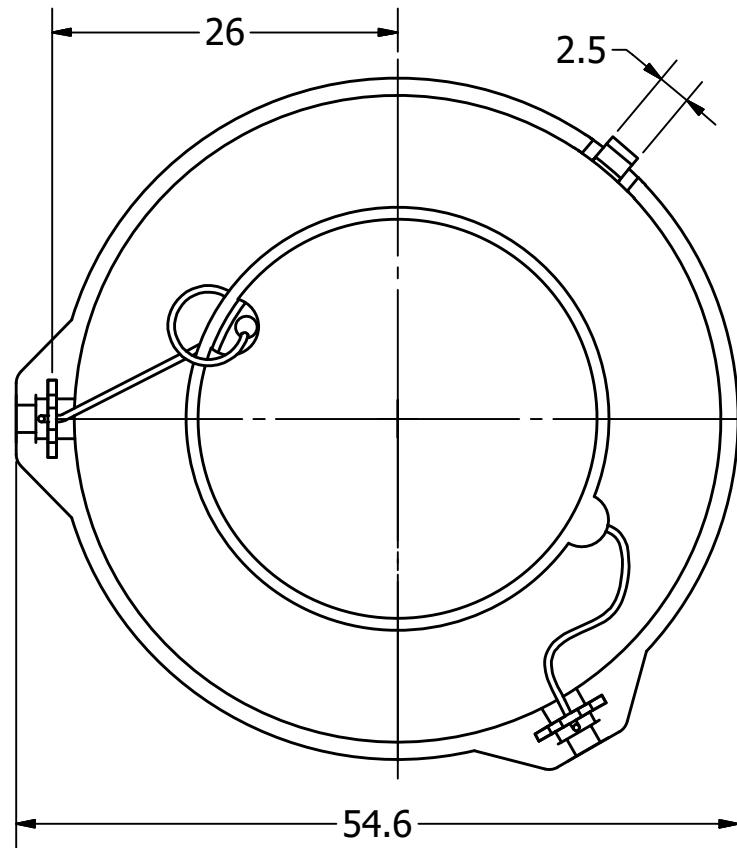
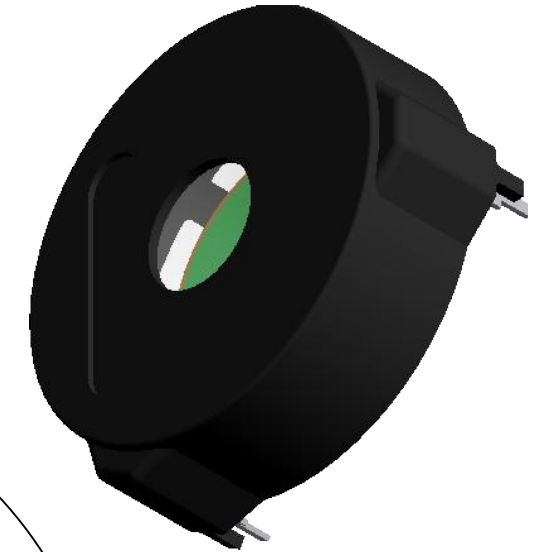

### NOTES:

1. ALL DIMENSIONS ARE IN MILLIMETERS.
2. SPECIFICATIONS SUBJECT TO CHANGE OR WITHDRAWL WITHOUT NOTICE.
3. THIS PART IS RoHS 2011/65/EU COMPLIANT.
4. MANUAL SOLDER ONLY.

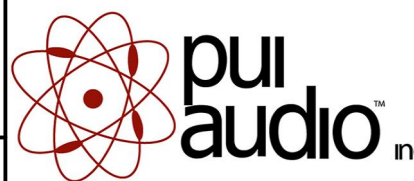
UNLESS OTHERWISE SPECIFIED: DIMENSIONS ARE IN MILLIMETERS, TOLERANCES ARE ±0.5 AND ANGLES ARE ±3°.	SIZE <b>A3</b>	Designed by	Date	Checked by	Date	Approved by	Date	Drawn Date
		J.D.	11/22/2006	D.F.	11/22/2006	R.W.	11/22/2006	10/6/2008
AT-5210-TT-R.idw				<b>AT-5210-TT-R</b>			Transducer (Piezo)	
							Edition	Sheet
							-	1 / 1