

Ultra-miniature, Low Power, 32.768kHz MEMS Oscillator



1.54 x 0.84 x 0.60mm

ASTMKJ



RoHS/RoHS II compliant

Moisture Sensitivity Level (MSL) – 1

FEATURES:

- Ultra-miniature size: 1.54 x 0.84 x 0.6mm
- Supply Voltage: 1.2V to 3.63V (-10 ~ +70°C); 1.5V to 3.63V (-40 ~ +85°C)
- Ultra-Low Current Consumption: 1.4µA max. (core current, no load)
- Frequency Stabilities include:
 - ±75ppm over -10 to +70°C
 - ±100ppm over -40 to +85°C
- Internal power supply filtering eliminates external bypass capacitor for Vdd port.
- High Performance MEMS Technology by SiTime
- Proprietary NanoDrive™ Technology by SiTime enables programmable output swing for lower power

APPLICATIONS:

- Timekeeping
- Battery Management
- Mobile devices
- RTC reference clock
- Wireless accessories
- Fitness/Medical monitoring sensors
- Sport video cams

STANDARD SPECIFICATIONS:

Parameters	Min	Typ	Max	Unit	Notes
Output Frequency (F _{out})	32.768			kHz	
Initial Frequency Tolerance (F _{tol}) ⁽¹⁾⁽⁵⁾	-10		+10	ppm	T _A = +25°C, post reflow, V _{dd} :1.5-3.63V
Frequency Stability over Temperature (F _{stab}) ⁽²⁾	-75		+75	ppm	T _A = -10°C to +70°C, V _{dd} :1.5-3.63V
	-100		+100		T _A = -40°C to +85°C, V _{dd} :1.5-3.63V
	-250		+250		T _A = -10°C to +70°C, V _{dd} :1.2-1.5V
Aging (@+25°C)	-1		+1	ppm	First year
Supply Voltage (V _{dd})	1.2		3.63	V	T _A = -10°C to +70°C
	1.5		3.63		T _A = -40°C to +85°C
Core Operating Current (I _{dd}) ⁽³⁾		0.90		µA	T _A = +25°C, V _{dd} : 1.8V. No load.
			1.3		T _A = -10°C to +70°C, V _{dd} max: 3.63V. No load
			1.4		T _A = -40°C to +85°C, V _{dd} max: 3.63V. No load.
Output Stage Operating Current (I _{dd out}) ⁽³⁾		0.065	0.125	µA/V _{pp}	T _A = -40°C to +85°C, V _{dd} max: 1.5-3.63V. No load.
Power Supply Ramp (t _{vdd_Ramp})			100	ms	T _A = -40°C to +85°C, 0 to 90%*V _{dd}
Start-up Time at Power-up (T _{start}) ⁽⁴⁾		180	300	ms	T _A = -40°C ≤ T _A ≤ +50°C, valid output
			450		T _A = +50°C ≤ T _A ≤ +85°C, valid output
Operating Temperature Range (T _{use})	-10		+70	°C	Option "M"
	-40		+85		Option "L"
Period Jitter		35		ns _{RMS}	Cycles=10000, T _A = +25°C, V _{dd} :1.5-3.63V
LVC MOS Output Option (T _A = -40°C to +85°C. Typical values are at T _A = +25°C)					
Output Rise/Fall Time (t _r /t _f)		100	200	ns	10-90%(V _{dd}), 15pF load, V _{dd} :1.5-3.63V
			50		10-90%(V _{dd}), 5pF load, V _{dd} ≥1.62V
Output Clock Duty Cycle	48		52	%	
Output Voltage	V _{OH}	90%*V _{dd}		V	V _{dd} :1.5-3.63V. I _{OH} = -10µA, 15pF
	V _{OL}		10%*V _{dd}		V _{dd} :1.5-3.63V. I _{OL} = 10µA, 15pF
NanoDrive™⁽⁶⁾ Programmable, Reduced Swing Output Option					
Output Rise/Fall Time (t _r /t _f)			200	ns	30-70%(V _{OL} / V _{OH}), 10pF load
Output Clock Duty Cycle	48		52	%	
AC-coupled Programmable Output Swing (V _{sw})		0.20 to 0.80		V	ASTMKJ does not internally AC-couple. This output description is intended for a receiver that is AC-coupled. See Part Identification section for available AC-coupled signal swing options. V _{dd} :1.5-3.63V. 10pF load, I _{OH} / I _{OL} =±0.2µA

Ultra-miniature, Low Power, 32.768kHz MEMS Oscillator

ASTMKJ



RoHS/RoHS II compliant



1.54 x 0.84 x 0.60mm

(Continued)

Parameters	Min	Typ	Max	Unit	Notes
DC-biased Programmable Output Voltage High Range (V_{OH})		0.60 to 1.225		V	V_{dd} : 1.5-3.63V. $I_{OH} = -0.2\mu A$. 10pF load. See Part Identification section for available V_{OH}/V_{OL} levels.
DC-biased Programmable Output Voltage Low Range (V_{OL})		0.35 to 0.80		V	V_{dd} : 1.5-3.63V. $I_{OL} = 0.2\mu A$. 10pF load. See Part Identification section for available V_{OH}/V_{OL} levels.
Programmable Output Voltage Swing Tolerance	-0.055		+0.055	V	$T_A = -40^\circ C$ to $+85^\circ C$, V_{dd} : 1.5-3.63V

Note:

1. Measured peak-to-peak. Tested with Agilent 53132A frequency counter. Due to the low operating frequency, the gate time must be $\geq 100ms$ to ensure an accurate frequency measurement.
2. Stability is specified for two operating voltage ranges. Stability progressively degrades with supply voltage below 1.5V. Measured peak-to-peak. Inclusive of initial tolerance at $+25^\circ C$, and variations over operating temperature, rated power supply voltage and load.
3. Core operating current does not include output driver operating current or load current. To derive total operating current (no load), add core operating current + output driver operating current, where output driver operating current = $C_{driver} * V_{out} * F_{out}$.
4. Measured from the time V_{dd} reaches 1.5V.
5. Board-level underfill (BLUF) is not recommended as it will cause a shift in the frequency tolerance.
6. NanoDrive™ is a SiTime trademark.

Absolute Maximum Ratings

Attempted operation outside the absolute maximum ratings may cause permanent damage to the part. Actual performance of the IC is only guaranteed within the operational specifications, not at absolute maximum ratings.

Parameters	Test Condition	Value	Unit
Continuous Power Supply Voltage Range (V_{dd})		-0.5 to 3.63	V
Short Duration Max. Power Supply Voltage (V_{dd})	≤ 30 minutes	4.0	V
Continuous Maximum Operating Temperature Range	V_{dd} : 1.5-3.63V	105	$^\circ C$
Short Duration Max. Operating Temperature Range	V_{dd} : 1.5-3.63V, ≤ 30 minutes	125	$^\circ C$
Human Body Model (HBM) ESD Protection	JESD22-A114	3000	V
Charge-Device Model (CDM) ESD Protection	JESD22-C101	750	V
Machine Model (MM) ESD Protection	JESD22-A115	300	V
Latch-up Tolerance	JESD78 Compliant		
Mechanical Shock Resistance	Mil 883, Method 2002	10000	g
Mechanical Vibration Resistance	Mil 883, Method 2007	70	g
1508 CSP Junction Temperature		150	$^\circ C$
Storage Temperature		-65 to +150	$^\circ C$

Ultra-miniature, Low Power, 32.768kHz MEMS Oscillator



1.54 x 0.84 x 0.60mm

ASTMKJ



RoHS/RoHS II compliant

Block Diagram

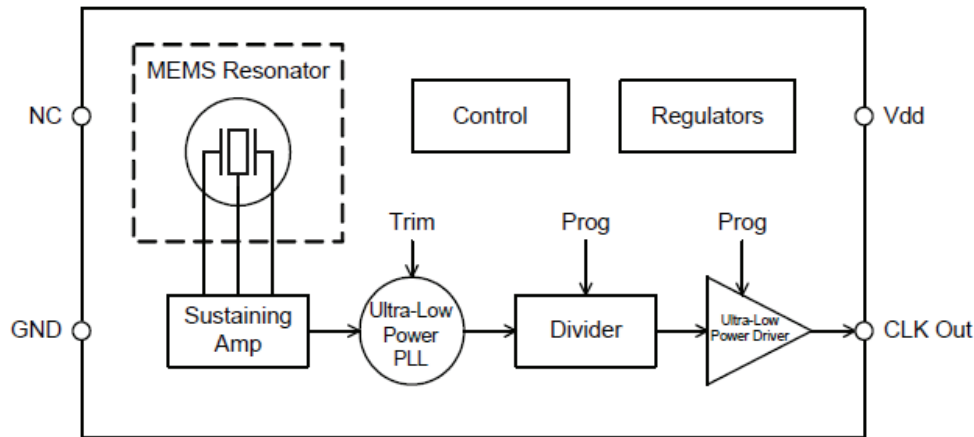

PART IDENTIFICATION:

ASTMKJ - 32.768 kHz - - -

Operating Temp.
M: -10°C ~ +70°C
L: -40°C ~ +85°C

Freq. Stability
P: ±75ppm (-10°C ~ +70°C only)
Q: ±100 ppm (-40°C ~ +85°C only)

Packaging
Blank: Bulk
T: Tape & Reel (1kpcs / reel)
T3: Tape & Reel (3kpcs / reel)
T10: Tape & Reel (10kpcs / reel)

Output Level Option
DCC: Rail-to-Rail LVCMOS
AA3: AC-coupled signal, swing level: 0.3V min.
D14: DC-coupled signal, V _{OL} : 0.400V max, V _{OH} : 1.100V min
D26: DC-coupled signal, V _{OL} : 0.525V max, V _{OH} : 1.225V min

Ultra-miniature, Low Power, 32.768kHz MEMS Oscillator

ASTMKJ



RoHS/RoHS II compliant



1.54 x 0.84 x 0.60mm

Typical Performance Data (TA=25°C, Vdd=1.8V, unless otherwise stated)

Initial Tolerance Histogram

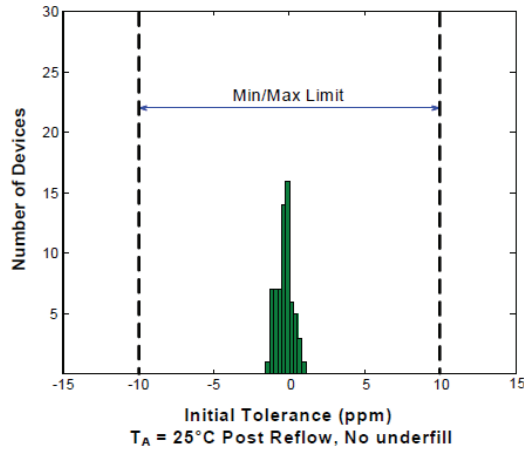

Frequency Stability vs. Operating Temperature Range

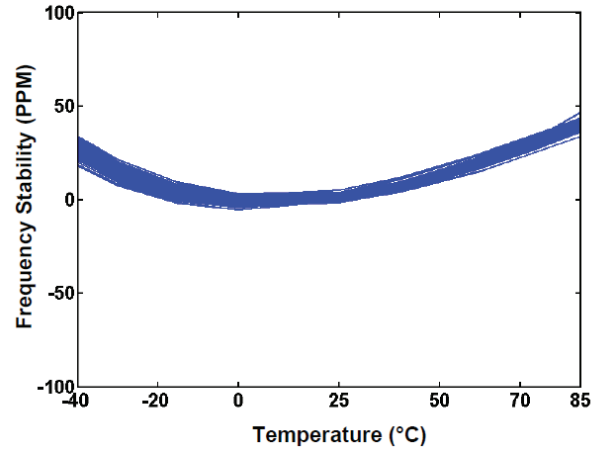

Core Current vs. Operating Temperature Range

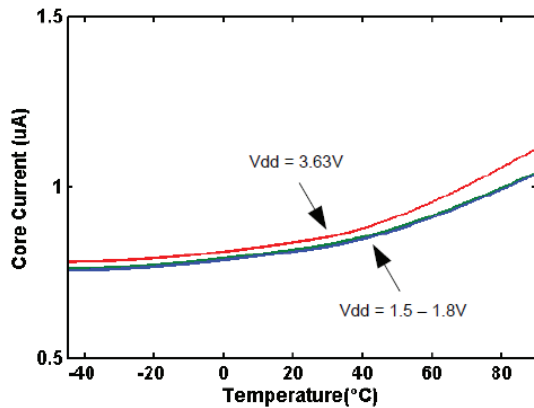

Output Stage Current vs. Operating Temperature Range

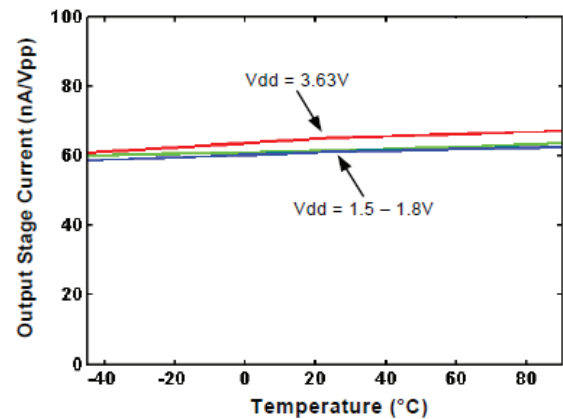

Start-up Time

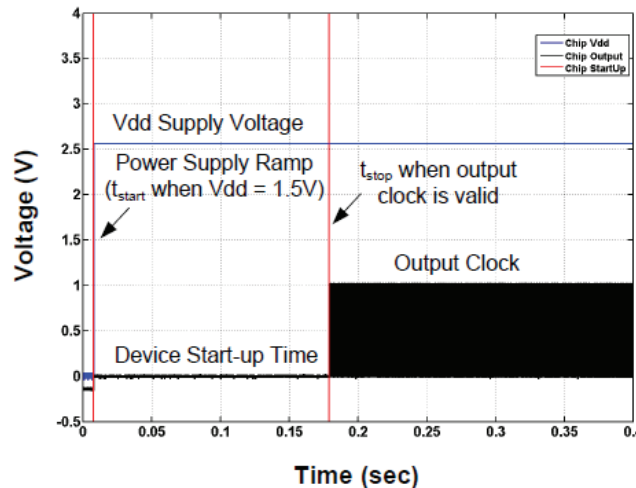

Ultra-miniature, Low Power, 32.768kHz MEMS Oscillator

ASTMKJ



RoHS/RoHS II compliant



1.54 x 0.84 x 0.60mm

Typical Performance Data (TA=25°C, Vdd=1.8V, unless otherwise stated)---(Continued)

Power Supply Noise Rejection ($\pm 150\text{mV}$ Noise)

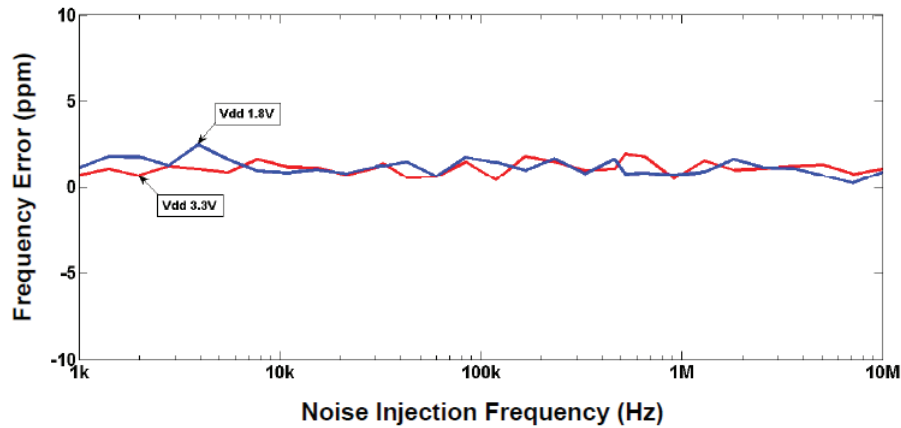

NanoDrive™ Output Waveform ($V_{OH} = 1.1\text{V}$, $V_{OL} = 0.4\text{V}$)

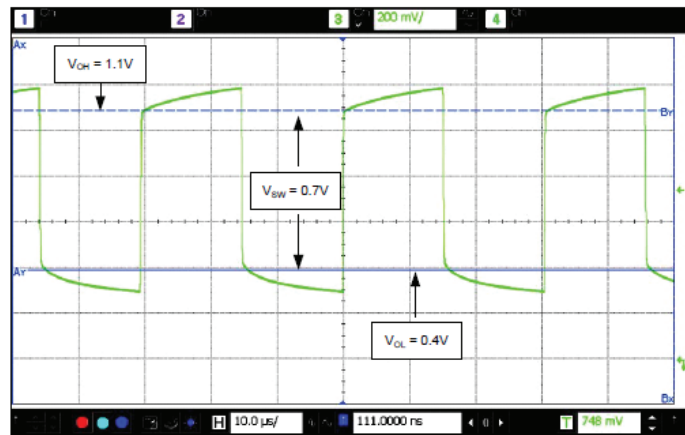

LVC MOS Output Waveform ($V_{\text{swing}} = 1.8\text{V}$)

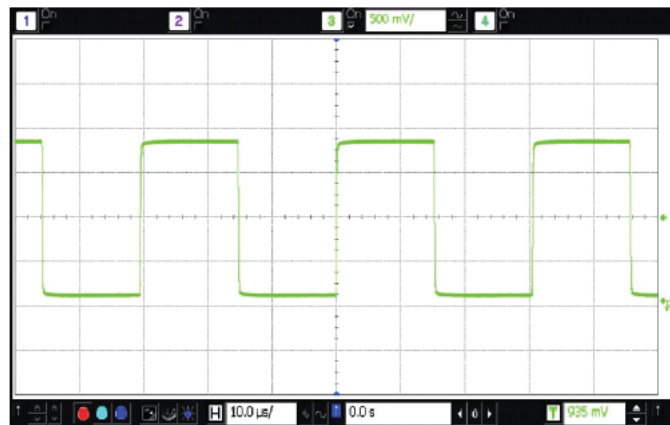

Ultra-miniature, Low Power, 32.768kHz MEMS Oscillator

ASTMKJ



RoHS/RoHS II compliant



1.54 x 0.84 x 0.60mm

OUTLINE DIMENSION:

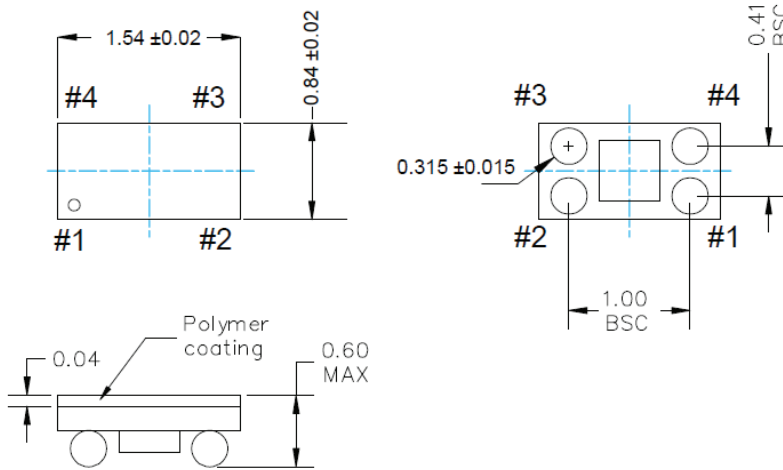

Recommended Land Pattern

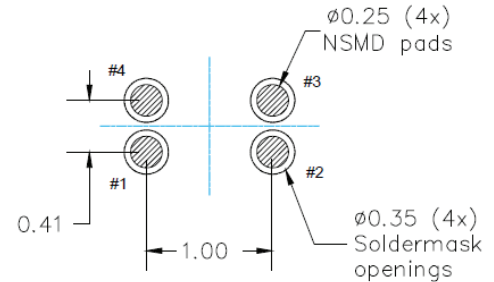

(soldermask openings shown with heavy dashed line)

Recommend 4-mil (0.1mm) stencil thickness

Pin	Name	I/O	Functionality
1,4	GND	Power Supply Ground	Connect to ground. Acceptable to connect pin 1 and 4 together. Both pins must be connected to GND.
2	CLK Out	OUT	Oscillator clock output.
3	V _{dd}	Power Supply	Connect to power supply $1.2V \leq V_{dd} \leq 3.63V$. Under normal operating conditions, V _{dd} doesn't require external bypass/decoupling capacitor(s). Internal power supply filtering will reject more than $\pm 150mV_{pp}$ with frequency components through 10MHz.

Dimensions: mm

REFLOW PROFILE:

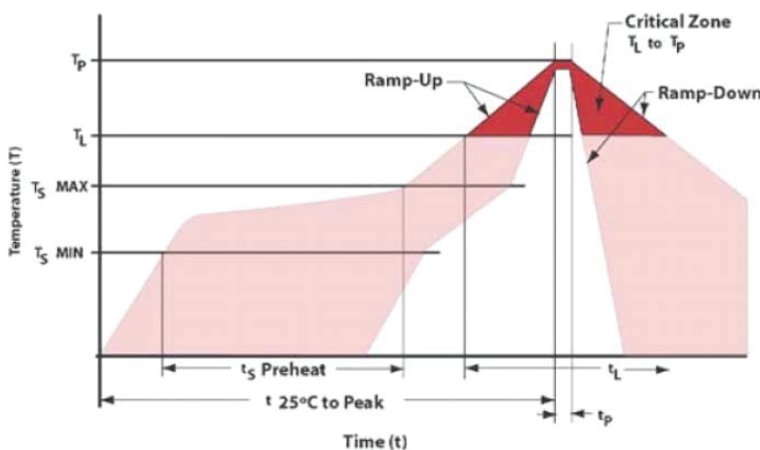

Item	Conditions
T _S MAX to T _L (Ramp-up Rate)	3°C/second max
Preheat	
Temperature Minimum (T _S MIN)	150°C
Temperature Typical (T _S TYP)	175°C
Temperature Maximum (T _S MAX)	200°C
Time (t _S)	60 – 180 seconds
Ramp-up Rate (T _L to T _P)	3°C/second max
Time Maintained Above	
Temperature (T _L)	217°C
Time (t _L)	60 – 150 seconds
Peak Temperature (T _P)	260°C max
Target Peak Temperature (T _P Target)	255°C
Time within 5°C of actual peak (t _P)	20 – 40 seconds
Max. Number of Reflow Cycles	3
Ramp-down Rate	6°C/second max
Time 25°C to Peak Temperature (t)	8 minutes max

Ultra-miniature, Low Power, 32.768kHz MEMS Oscillator

ASTMKJ



RoHS/RoHS II compliant

1.54 x 0.84 x 0.60mm

TAPE & REEL:

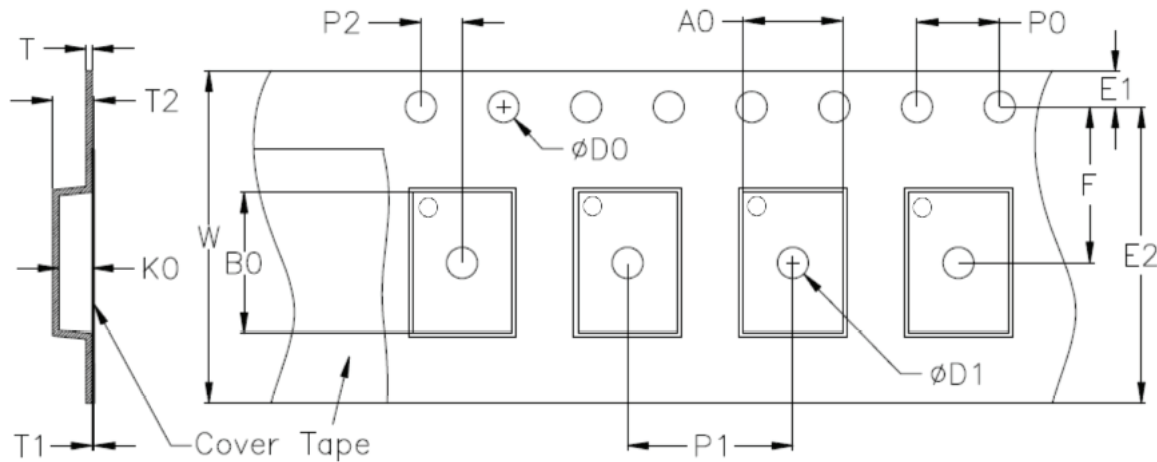

Unit: mm

D0	D1 min.	E1	E2 min.	F	P0	P1	P2
1.55±0.05	0.18	1.75±0.1	6.05	3.5±0.05	4.0±0.1	4.0±0.1	2.0±0.05
T	T1 max.	T2 max.	W max.	A0	B0	K0	
0.20±0.02	0.1	1.55	8.3	0.96±0.03	1.66±0.03	0.63±0.03	

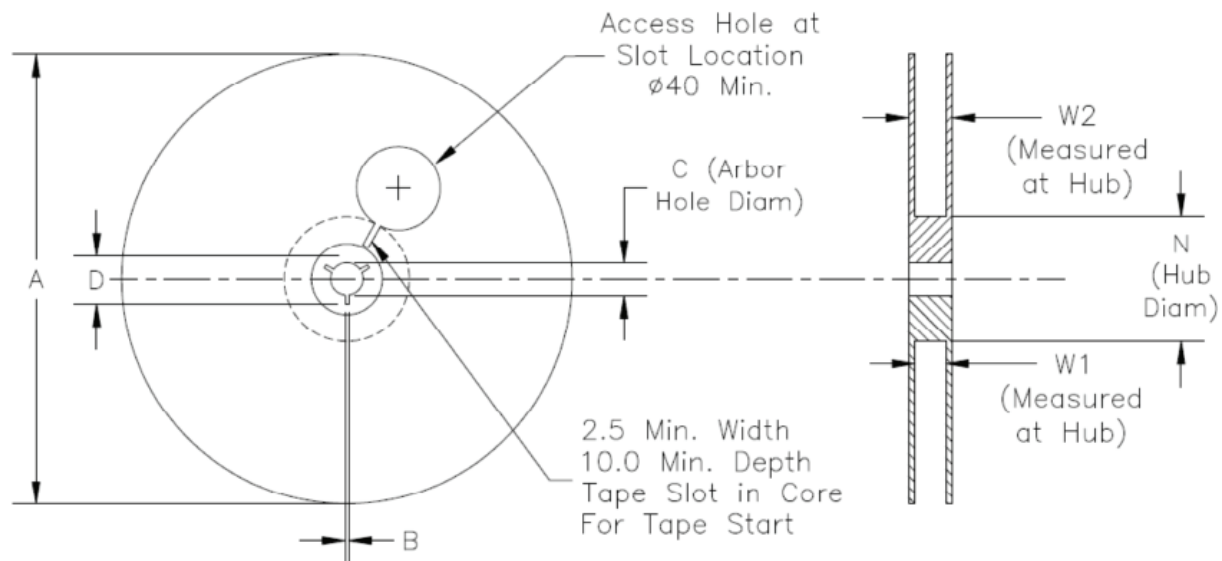

Unit: mm

Option	A max.	B min.	C	D min.	N	W1	W2 max.
T & T3	180	1.5	13.0+0.6/-0.2	20.2	60±0.5	8.4+1.5/-0	14.4
T10	330	1.5	13.0±0.2	20.2	100±0.5	8.4+1.5/-0	14.4

T= Tape and reel (1,000pcs/reel)
 T3= Tape and reel (3,000pcs/reel)
 T10= Tape and reel (10,000pcs/reel)

ATTENTION: Abracon Corporation's products are COTS – Commercial-Off-The-Shelf products; suitable for Commercial, Industrial and, where designated, Automotive Applications. Abracon's products are not specifically designed for Military, Aviation, Aerospace, Life-dependant Medical applications or any application requiring high reliability where component failure could result in loss of life and/or property. For applications requiring high reliability and/or presenting an extreme operating environment, written consent and authorization from Abracon Corporation is required. Please contact Abracon Corporation for more information.

ABRACON IS
 ISO9001:2008
 CERTIFIED



2 Faraday, Suite# B | Irvine | CA 92618 Revised: 06.30.15
 Ph. 949.546.8000 | Fax. 949.546.8001
 Visit www.abracon.com for Terms and Conditions of Sale