

DO NOT SCALE FROM THIS PRINT

- NOTES:
 1. ITEMS -1, -2, & -3 NOT AVAILABLE AS STANDARD.
 2. Ⓢ REPRESENTS A CRITICAL DIMENSION.
 3. MINIMUM PUSHOUT FORCE: .5 LB.
 4. MAXIMUM ALLOWABLE BOW: TOP/BOTTOM: .004[0.10], SIDE/SIDE: .003[0.08].
 5. PARTS TO BE TUBE PACKAGED.

THIS CONNECTOR IS NOT CAPABLE OF WITHSTANDING TYPICAL LEAD FREE PROCESSING TEMPERATURES.

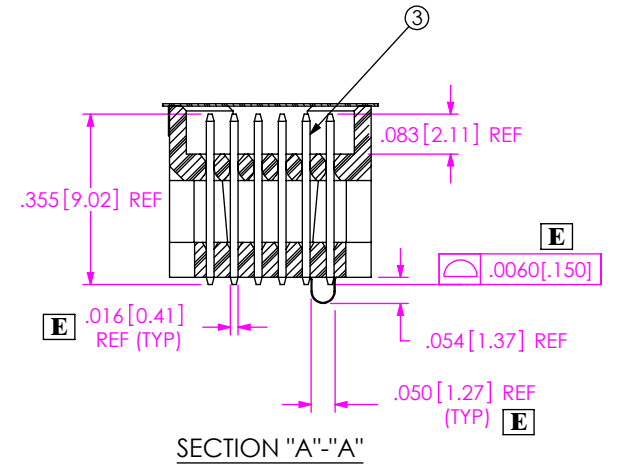
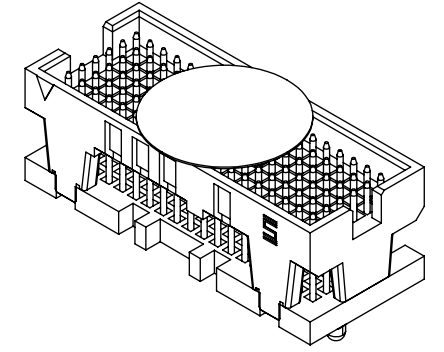
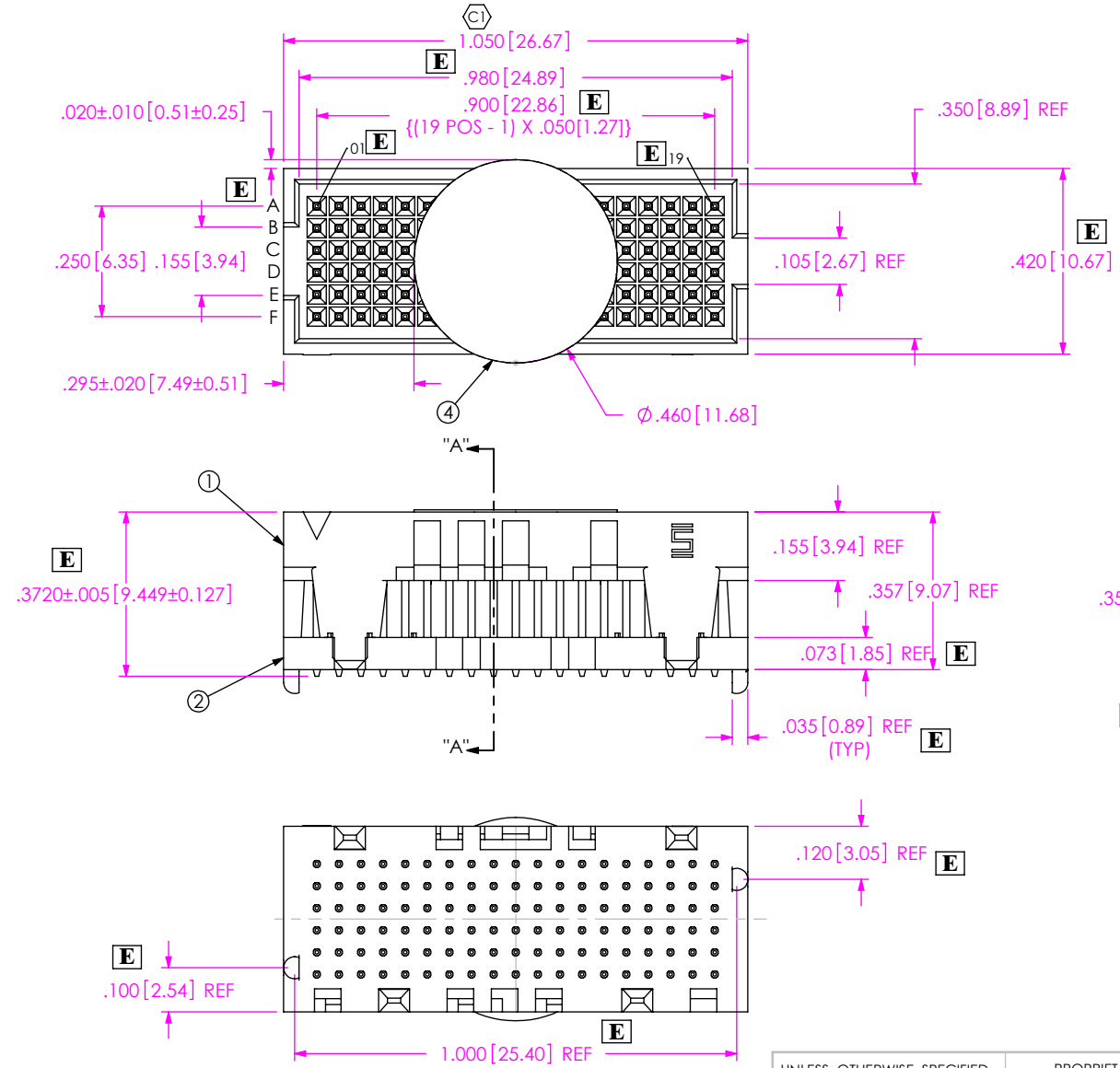

ITEM NO.	PART NUMBER	QUANTITY	MATERIAL
1	ASP-105991-01-B	1.0000	UL 94 V0, COLOR: BLACK, UL RATING 94V-0
2	ASP-105991-02-B	1.0000	UL 94 V0, COLOR: BLACK
3	ASP-105992-02-P-H	114.00	BRASS ALLOY 260, 3/4 HARD
4	K-850-650	1.0000	POLYIMIDE FILM
5	PT-1-24-01-08	.23000	ANTI-STATIC PVC
6	TP-13	.46000	THERMOPLASTIC RUBBER

UNLESS OTHERWISE SPECIFIED, DIMENSIONS ARE IN INCHES. TOLERANCES ARE: DECIMALS ANGLES .XX: ±.01[.3] 2° .XXX: ±.005[.13] .XXXX: ±.0020[.051]	PROPRIETARY NOTE THIS DOCUMENT CONTAINS INFORMATION CONFIDENTIAL AND PROPRIETARY TO SAMTEC, INC. AND SHALL NOT BE REPRODUCED OR TRANSFERRED TO OTHER DOCUMENTS OR DISCLOSED TO OTHERS OR USED FOR ANY PURPOSE OTHER THAN THAT WHICH IT WAS OBTAINED WITHOUT THE EXPRESSED WRITTEN CONSENT OF SAMTEC, INC.	520 PARK EAST BLVD, NEW ALBANY, IN 47150 PHONE: 812-944-6733 FAX: 812-948-5047 e-Mail: info@SAMTEC.com code 55322

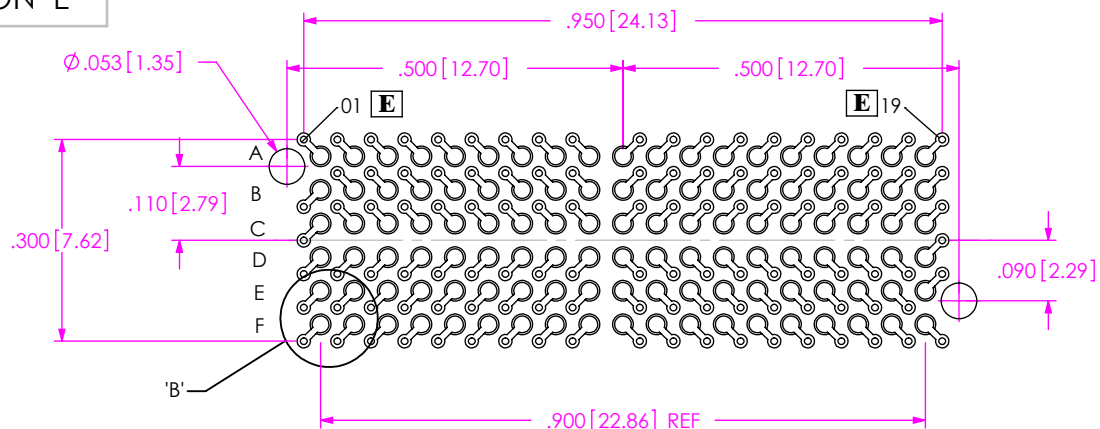

RECOMMENDED BOARD LAYOUT

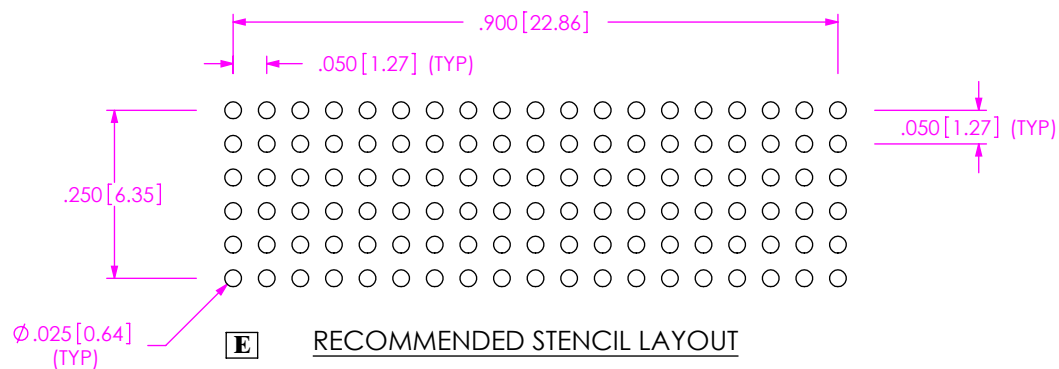

RECOMMENDED STENCIL LAYOUT

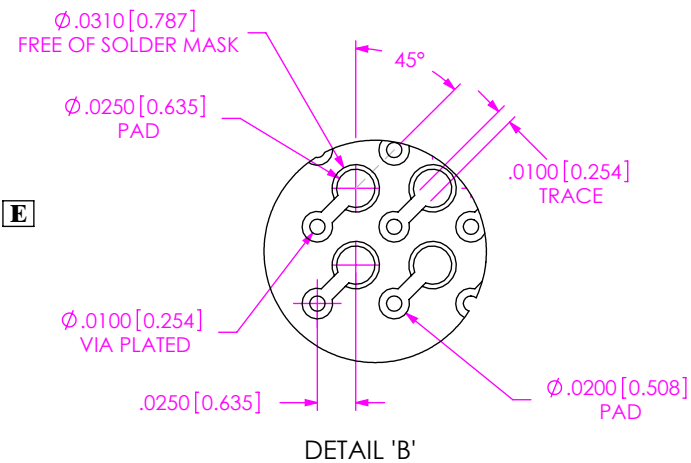

DETAIL 'B'

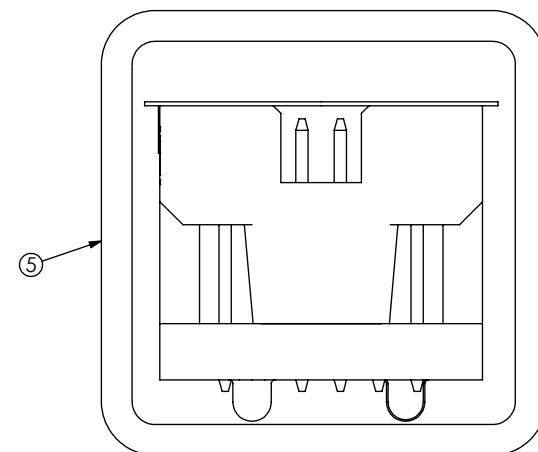

PACKAGING VIEW

PROPRIETARY NOTE

THIS DOCUMENT CONTAINS INFORMATION CONFIDENTIAL AND PROPRIETARY TO SAMTEC, INC. AND SHALL NOT BE REPRODUCED OR TRANSFERRED TO OTHER DOCUMENTS OR DISCLOSED TO OTHERS OR USED FOR ANY PURPOSE OTHER THAN THAT WHICH IT WAS OBTAINED WITHOUT THE EXPRESSED WRITTEN CONSENT OF SAMTEC, INC.

E SHEET SCALE: 3.5:1

samtec

520 PARK EAST BLVD., NEW ALBANY, IN 47150
PHONE: 812-944-6733 FAX: 812-948-5047
e-Mail info@SAMTEC.com code 55322

DESCRIPTION: VITA 42 (NON SOLDERBALL) SOCKET ASSEMBLY **E**

DWG. NO. ASP-105885-04