

ASMT-YTB7-0AA02

Tricolor PLCC6 Black Surface LED

Description

This family of SMT LEDs packaged in the form of PLCC-6 with separate heat path for each LED dice, enabling it to be driven at higher current.

Individually addressable pin-outs give higher flexibility in circuitry design. With closely matched radiation pattern along the package's X-axis, these LEDs are suitable for indoor full color display applications. The black top surface of the LED provides better contrast enhancement.

For easy pick-and-place, the LEDs are shipped in tape and reel. Every reel is shipped from a single intensity and color bin for better uniformity.

These LEDs are compatible with reflow soldering process.

Features

- Standard PLCC-6 package (Plastic Leaded Chip Carrier) with individual addressable pin-out for higher flexibility of driving configuration
- LED package with diffused silicone encapsulation
- Using AlInGaP and InGaN dice technologies
- Typical viewing angle 120°
- Compatible with reflow soldering process
- JEDEC MSL 3
- Water-Resistance (IPX6, see note) per IEC 60529:2001

NOTE: The test is conducted on the component level by mounting the components on the PCB with proper potting to protect the leads. It is strongly recommended that customers perform the necessary tests on the components for their final application.

Applications

- Full color display

CAUTION! These LEDs are Class 1C ESD sensitive. Observe appropriate precautions during handling and processing. For additional details, refer to Broadcom[®] Application Note AN-1142.

CAUTION! The customer is advised to keep the LED in the MBB when not in use as prolonged exposure to environment might cause the silver-plated leads to tarnish, which might cause difficulties in soldering.

Package Dimensions

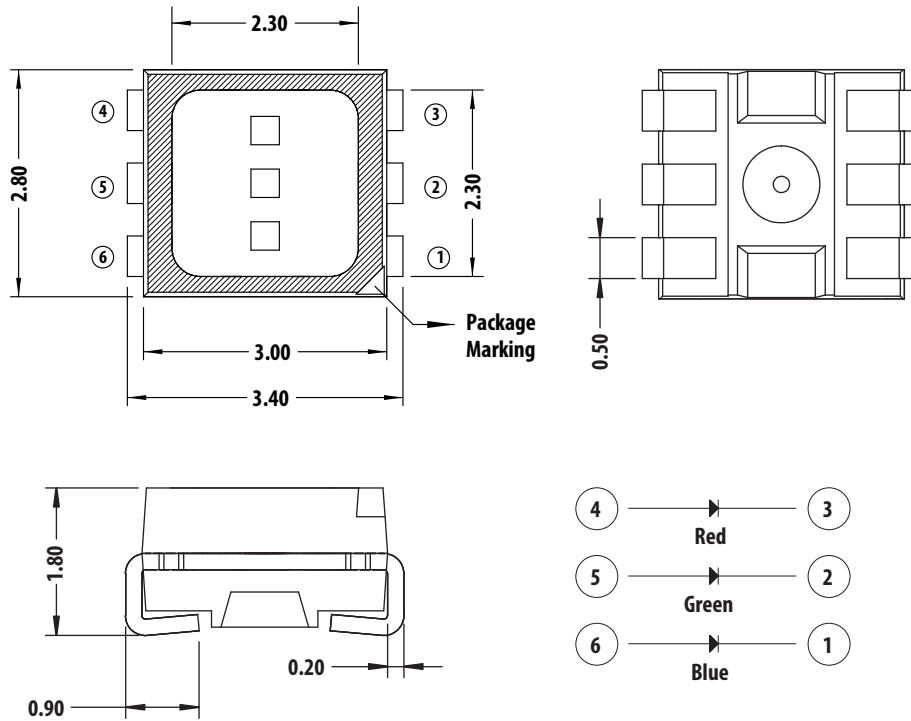

Lead Configuration

| Pin | Description |
|-----|-----------------|
| 1 | Cathode (Blue) |
| 2 | Cathode (Green) |
| 3 | Cathode (Red) |
| 4 | Anode (Red) |
| 5 | Anode (Green) |
| 6 | Anode (Blue) |

NOTE:

1. All dimensions are in millimeter (mm).
2. Unless otherwise specified, tolerance is ± 0.20 mm.
3. Encapsulation = silicone.
4. Terminal finish = silver plating.

Table 1: Absolute Maximum Ratings ($T_J = 25^\circ\text{C}$)

| Parameter | Red | Green and Blue | Units |
|--|---------------|----------------|------------------|
| DC forward current ^a | 50 | 25 | mA |
| Peak forward current ^b | 100 | 100 | mA |
| Power dissipation | 125 | 90 | mW |
| Maximum junction temperature T_J max | 110 | | $^\circ\text{C}$ |
| Operating temperature range | - 40 to + 100 | | $^\circ\text{C}$ |
| Storage temperature range | - 40 to + 100 | | $^\circ\text{C}$ |

- a. Derate linearly as shown in [Figure 7](#) to [Figure 10](#).
b. Duty factor = 10%, frequency = 1 kHz.

Table 2: Optical Characteristics ($T_J = 25^\circ\text{C}$)

| Color | Luminous Intensity, I_V (mcd) at $I_F = 20\text{ mA}^a$ | | | Dominant Wavelength, λ_d (nm) at $I_F = 20\text{ mA}^b$ | | | Peak Wavelength, λ_P (nm) at $I_F = 20\text{ mA}$ | Viewing Angle, $2\theta_{1/2}$ ($^\circ$) ^c | Test Current (mA) |
|-------|--|------|------|--|------|------|---|---|----------------------|
| | Min. | Typ. | Max. | Min. | Typ. | Max. | Typ. | Typ. | |
| Red | 560 | 650 | 1125 | 617 | 623 | 627 | 630 | 120 | 20 |
| Green | 1400 | 1900 | 2850 | 525 | 529 | 537 | 522 | 120 | |
| Blue | 285 | 384 | 560 | 465 | 469 | 475 | 465 | 120 | |

- a. Luminous intensity, I_V is measured at the mechanical axis of the LED package at a single current pulse condition. The actual peak of the spatial radiation pattern may not be aligned with the axis.
b. Dominant wavelength is derived from the CIE Chromaticity Diagram and represents the perceived color of the device.
c. $\theta_{1/2}$ is the off-axis angle where the luminous intensity is $1/2$ of the peak intensity.

Table 3: Electrical Characteristics ($T_J = 25^\circ\text{C}$)

| Color | Forward Voltage, V_F (V) @ $I_F = 20\text{ mA}^a$ | | | Reverse Voltage, V_R (V) @ $I_R = 100\ \mu\text{A}^b$ | Reverse Voltage, V_R (V) @ $I_R = 10\ \mu\text{A}^b$ | Thermal Resistance, $R_{\theta J-S}$ ($^\circ\text{C}/\text{W}$) | |
|-------|---|------|------|--|---|--|------------|
| | Min. | Typ. | Max. | Min. | Min. | 1 chip on | 3 chips on |
| Red | 1.8 | 2.1 | 2.5 | 4.0 | -- | 280 | 330 |
| Green | 2.6 | 3.1 | 3.4 | -- | 4.0 | 240 | 357 |
| Blue | 2.6 | 3.1 | 3.4 | -- | 4.0 | 240 | 357 |

- a. Tolerance = $\pm 0.1\text{V}$.
b. Indicates product final testing condition. Long-term reverse bias is not recommended.

Part Numbering System

A S M T - Y T B 7 - 0 A A 0 2

| | | | | |
|----------------|----------------|----------------|----------------|----------------|
| x ₁ | x ₂ | x ₃ | x ₄ | x ₅ |
|----------------|----------------|----------------|----------------|----------------|

| Code | Description | Option | | |
|----------------|--------------------------|--------|-------------------------------|-----------------------|
| x ₁ | Package type | B | Black surface | |
| x ₂ | Minimum intensity bin | A | Red: bin U2 | Red: bin U2,V1,V2 |
| | | | Green: bin W2 | Green: bin W2, X1, X2 |
| | | | Blue: bin T1 | Blue: bin T1, T2, U1 |
| x ₃ | Number of intensity bins | A | 3 intensity bins from minimum | |
| x ₄ | Color bin combination | 0 | Red: full distribution | |
| | | | Green: bin A, B, C | |
| | | | Blue: bin A, B, C, D | |
| x ₅ | Test option | 2 | Test current = 20 mA | |

Bin Information

Table 4: Intensity Bins (CAT)

| Bin ID | Luminous intensity (mcd) | |
|--------|--------------------------|------|
| | Min. | Max. |
| T1 | 285 | 355 |
| T2 | 355 | 450 |
| U1 | 450 | 560 |
| U2 | 560 | 715 |
| V1 | 715 | 900 |
| V2 | 900 | 1125 |
| W1 | 1125 | 1400 |
| W2 | 1400 | 1800 |
| X1 | 1800 | 2240 |
| X2 | 2240 | 2850 |

Tolerance: $\pm 12\%$.

Table 5: Color Bins (BIN) – Blue

| Bin ID | Dominant Wavelength (nm) | | Chromaticity Coordinate (for Reference) | |
|--------|--------------------------|-------|---|--------|
| | Min. | Max. | Cx | Cy |
| A | 465.0 | 469.0 | 0.1355 | 0.0399 |
| | | | 0.1751 | 0.0986 |
| | | | 0.1680 | 0.1094 |
| | | | 0.1267 | 0.0534 |
| B | 467.0 | 471.0 | 0.1314 | 0.0459 |
| | | | 0.1718 | 0.1034 |
| | | | 0.1638 | 0.1167 |
| | | | 0.1215 | 0.0626 |
| C | 469.0 | 473.0 | 0.1267 | 0.0534 |
| | | | 0.1680 | 0.1094 |
| | | | 0.1593 | 0.1255 |
| | | | 0.1158 | 0.0736 |
| D | 471.0 | 475.0 | 0.1215 | 0.0626 |
| | | | 0.1638 | 0.1167 |
| | | | 0.1543 | 0.1361 |
| | | | 0.1096 | 0.0868 |

Tolerance: ± 1 nm.

Table 6: Color Bins (BIN) – Green

| Bin ID | Dominant Wavelength (nm) | | Chromaticity Coordinate (for Reference) | |
|--------|--------------------------|-------|---|--------|
| | Min. | Max. | Cx | Cy |
| A | 525.0 | 531.0 | 0.1142 | 0.8262 |
| | | | 0.1624 | 0.7178 |
| | | | 0.2001 | 0.6983 |
| | | | 0.1625 | 0.8012 |
| B | 528.0 | 534.0 | 0.1387 | 0.8148 |
| | | | 0.1815 | 0.7089 |
| | | | 0.2179 | 0.6870 |
| | | | 0.1854 | 0.7867 |
| C | 531.0 | 537.0 | 0.1625 | 0.8012 |
| | | | 0.2001 | 0.6983 |
| | | | 0.2353 | 0.6747 |
| | | | 0.2077 | 0.7711 |

Tolerance: ± 1 nm.

Table 7: Color Bins (BIN) – Red

| Bin ID | Dominant Wavelength (nm) | | Chromaticity Coordinate (for reference) | |
|--------|--------------------------|-------|---|--------|
| | Min. | Max. | Cx | Cy |
| — | 617.0 | 627.0 | 0.6850 | 0.3149 |
| | | | 0.6815 | 0.3150 |
| | | | 0.7000 | 0.2966 |
| | | | 0.7037 | 0.2962 |

Tolerance: ± 1 nm.

Figure 1: Relative Intensity vs. Wavelength

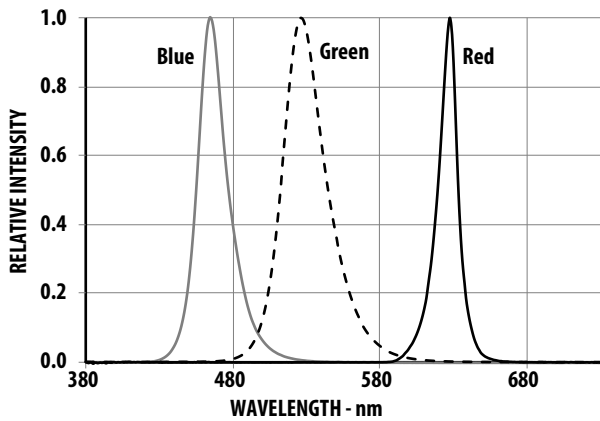

Figure 2: Forward Current – mA vs. Forward Voltage

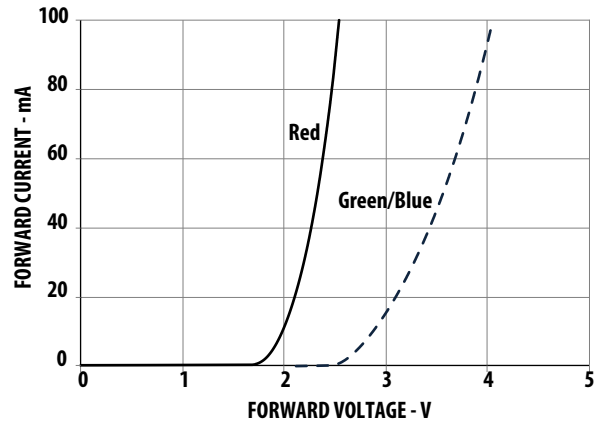

Figure 3: Relative Intensity vs. Forward Current

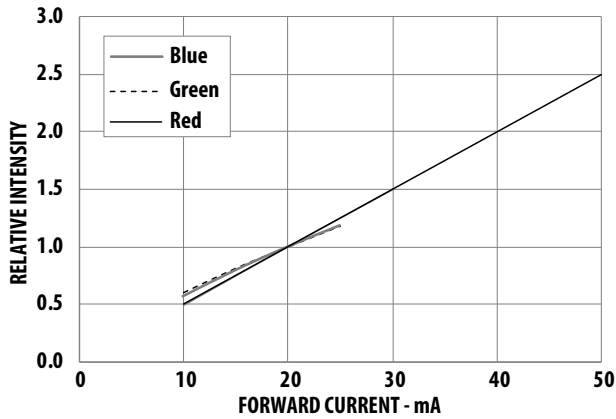

Figure 4: Dominant Wavelength Shift vs. Forward Current

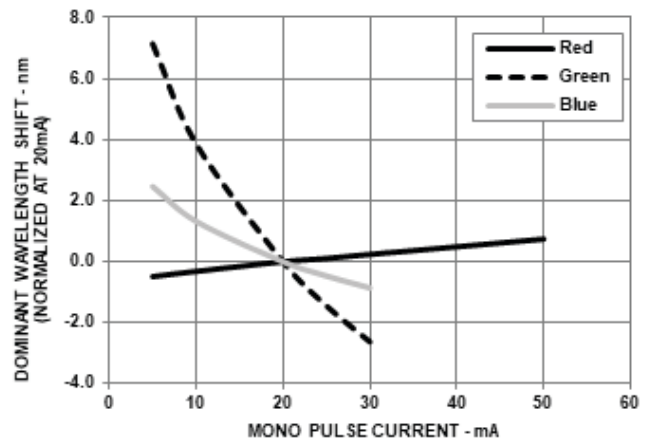

Figure 5: Relative Intensity vs. Junction Temperature

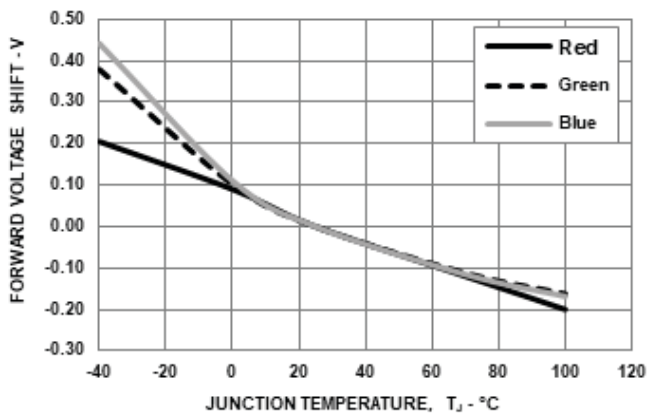

Figure 6: Forward Voltage vs. Junction Temperature

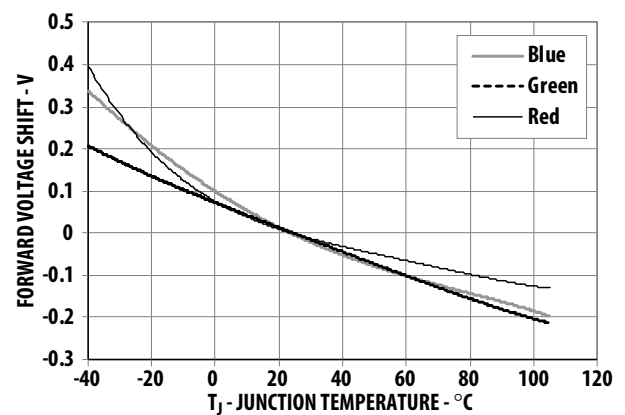

Figure 7: Maximum Forward Current vs. Temperature for Red (1 Chip On)

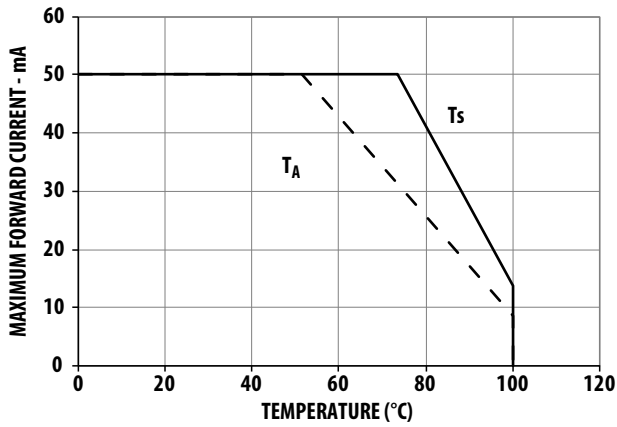

Figure 8: Maximum Forward Current vs. Temperature for Red (3 Chips On)

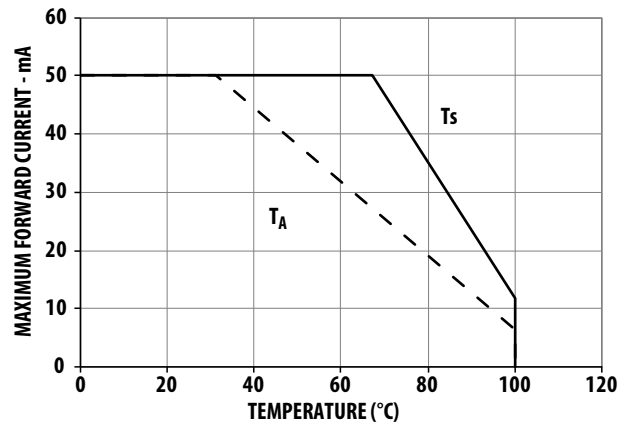

Figure 9: Maximum Forward Current vs. Temperature for Green and Blue (1 Chip On)

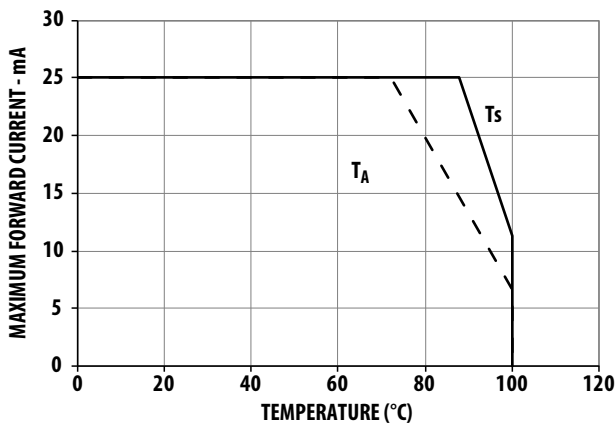
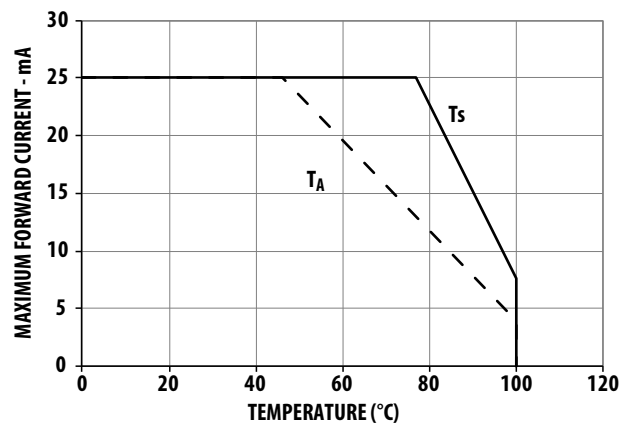

Figure 10: Maximum Forward Current vs. Temperature for Green and Blue (3 Chips On)



NOTE: Maximum forward current graphs based on ambient temperature, T_A are with reference to thermal resistance $R_{\theta J-A}$ as follows. For more details, see [Thermal Management](#).

| Condition | Thermal Resistance from LED Junction to Ambient, $R_{\theta J-A}$ (°C/W) | |
|------------|--|----------------|
| | Red | Green and Blue |
| 1 chip on | 450 | 410 |
| 3 chips on | 630 | 690 |

Figure 11: Radiation Pattern along X-axis of the Package

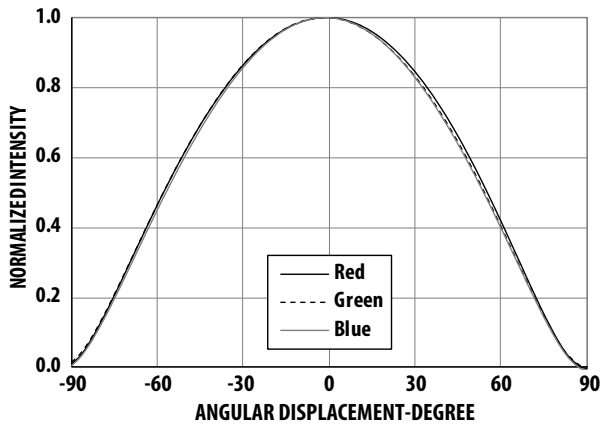

Figure 12: Radiation Pattern along Y-axis of the Package

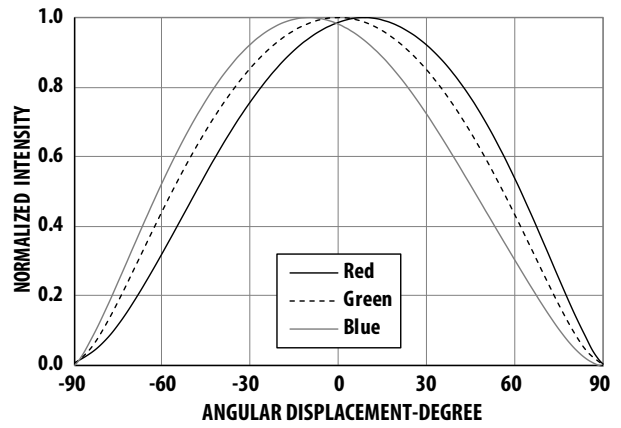

Figure 13: Illustration of Package Axis for Radiation Pattern

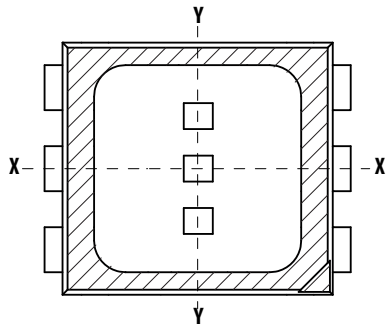

Figure 14: Recommended Soldering Land Pattern

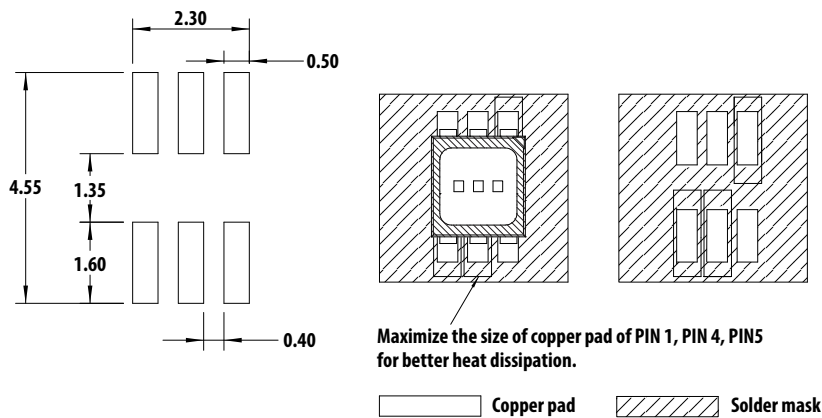

Figure 15: Carrier Tape Dimensions

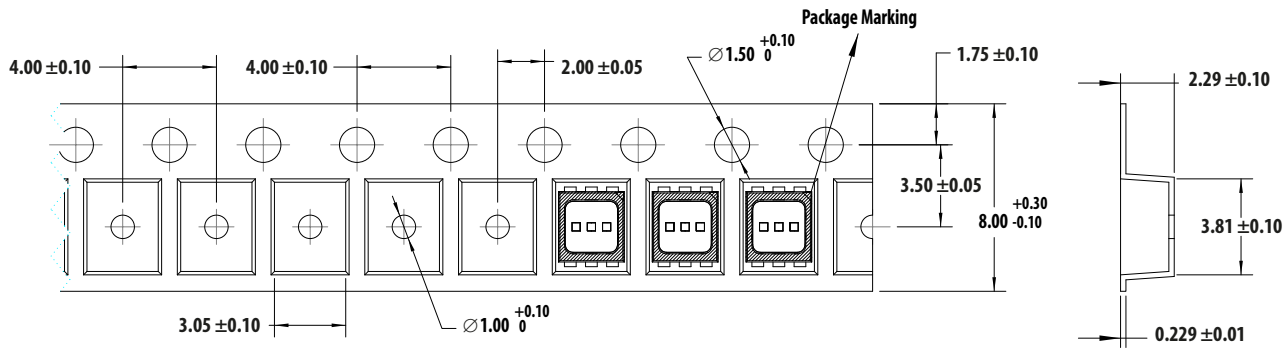

Figure 16: Reeling Orientation

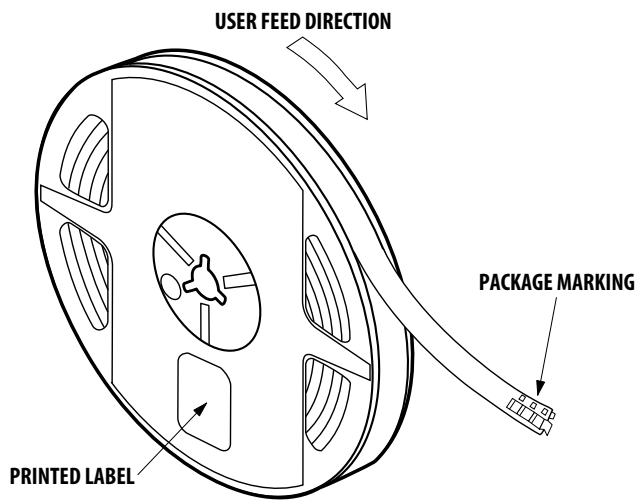
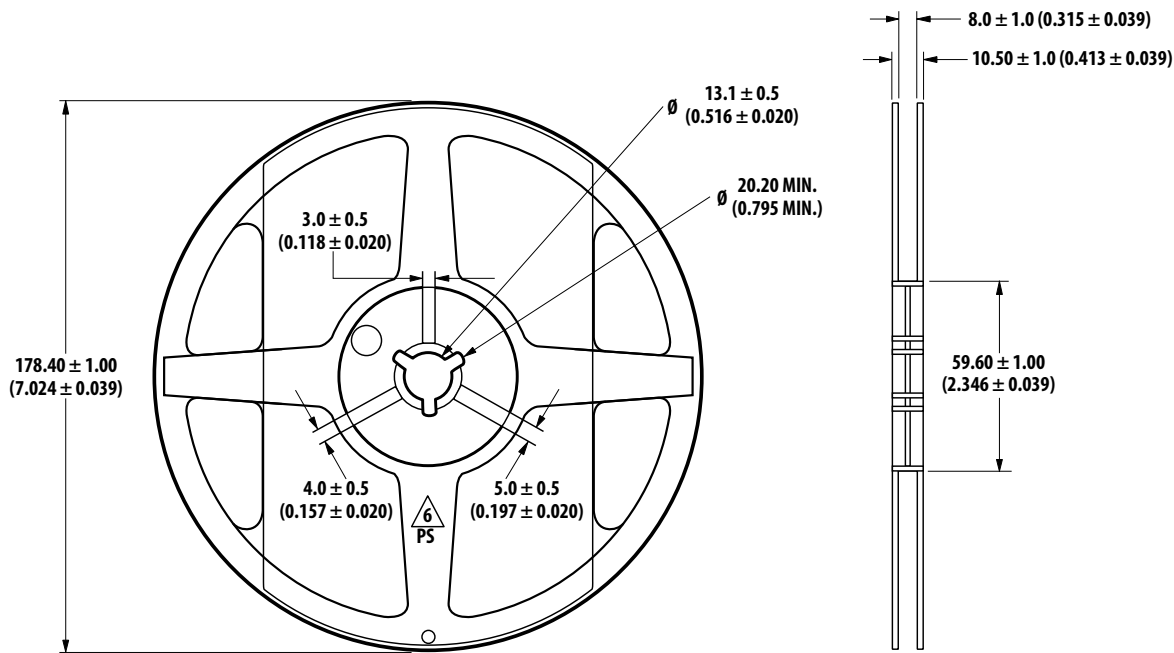

Figure 17: Reel Dimensions



Packing Label

Standard Label (Attached on Moisture Barrier Bag)

| | |
|----------------------------------|----------------------------|
| AVAGO | |
| TECHNOLOGIES | |
| STANDARD LABEL LS0002 | |
| RoHS Compliant Halogen Free | |
| e4 Max Temp 260C MSL3 | |
| (1P) Item: Part Number | (Q) QTY: Quantity |
| | |
| (1T) Lot: Lot Number | CAT: Intensity Bin |
| | |
| LPN: | BIN: Color Bin |
| | |
| (9D)MFG Date: Manufacturing Date | |
| | |
| (P) Customer Item: | |
| | |
| (V) Vendor ID: | (9D) Date Code: Date Code |
| | |
| DeptID: | Made In: Country of Origin |
| | |

Baby Label (Attached on Plastic Reel)







| | |
|---|--|
| (1P) PART #: Part Number  |  Avago TECHNOLOGIES BABY LABEL COSB001B V0.0 |
| (1T) LOT #: Lot Number  | |
| (9D)MFG DATE: Manufacturing Date  | QUANTITY: Packing Quantity  |
| C/O: Country of Origin | (9D): DATE CODE: |
| (1T) TAPE DATE:  | D/C: Date Code VF: CAT: INTENSITY BIN BIN: COLOR BIN |

Figure 18: Example of Luminous Intensity (Iv) Bin Information on Label

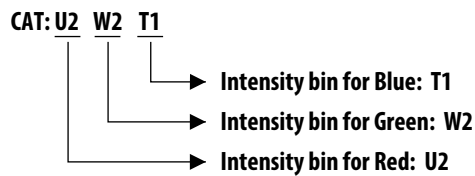
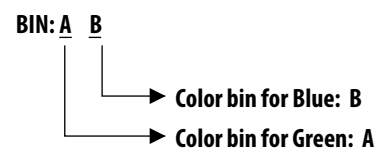

Figure 19: Example of Color Bin Information on Label



NOTE: There is no color bin ID for Red color as there is only 1 range, as stated in [Table 7](#).

Soldering

Recommended reflow soldering condition:

Figure 20: Leaded Reflow Soldering

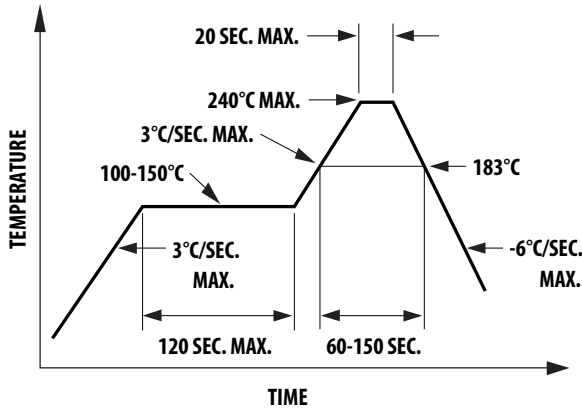

- Reflow soldering must not be done more than twice. Observe necessary precautions of handling moisture-sensitive devices as stated in the following section.
- Recommended board reflow direction is as follows.

Figure 22: Board Reflow Direction

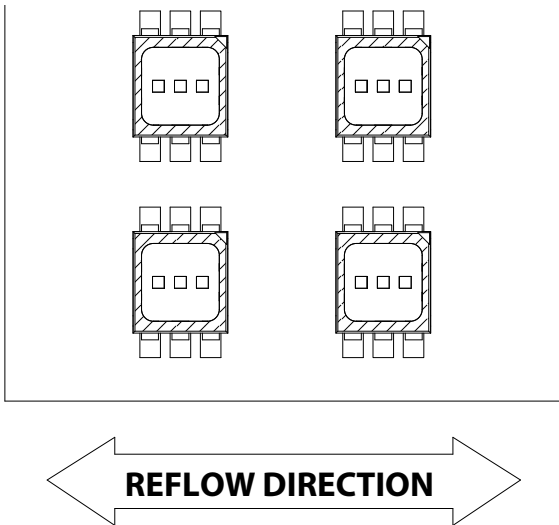
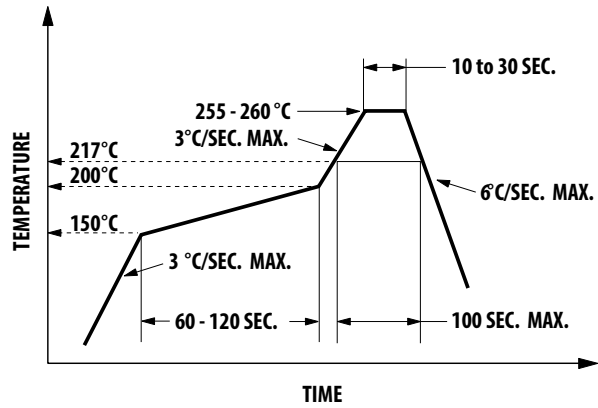

Figure 21: Lead-Free Reflow Soldering



- Do not apply any pressure or force on the LED during reflow and after reflow when the LED is still hot.
- Use reflow soldering to solder the LED. Use hand soldering for rework only if unavoidable but it must be strictly controlled to the following conditions:
 - Soldering iron tip temperature = 320°C maximum
 - Soldering duration = 3 seconds maximum
 - Number of cycle = 1 only
 - Power of soldering iron = 50W maximum
- Do not touch the LED body with the hot soldering iron except the soldering terminals as it may cause damage to the LED.
- For de-soldering, use a double flat tip.
- Confirm beforehand whether the functionality and performance of the LED is affected by hand soldering.

Precautionary Notes

Handling Precautions

The encapsulation material of the LED is made of silicone for better product reliability. Compared to epoxy encapsulant that is hard and brittle, silicone is softer and flexible. Special handling precautions need to be observed during assembly of silicone encapsulated LED products. Failure to comply might lead to damage and premature failure of the LED. Refer to Application Note AN5288, *Silicone Encapsulation for LED: Advantages and Handling Precautions* for more information.

- Do not poke sharp objects into the silicone encapsulant. Sharp objects, such as tweezers or syringes, might apply excessive force or even pierce through the silicone and induce failures to the LED die or wire bond.
- Do not touch the silicone encapsulant. Uncontrolled force acting on the silicone encapsulant might result in excessive stress on the wire bond. Hold the LED only by the body.
- Do not stack assembled PCBs together. Use an appropriate rack to hold the PCBs.
- The surface of the silicone material attracts dust and dirt easier than epoxy due to its surface tackiness. To remove foreign particles on the surface of silicone, use a cotton bud with isopropyl alcohol (IPA). During cleaning, rub the surface gently without putting much pressure on the silicone. Ultrasonic cleaning is not recommended.
- For automated pick-and-place, Broadcom has tested the following nozzle size to work well with this LED. However, due to the possibility of variations in other parameters, such as pick and place machine maker/model and other settings of the machine, verify that the nozzle selected will not cause damage to the LED.

Figure 23: Nozzle Size

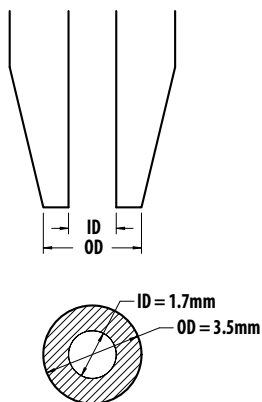

Handling of Moisture-Sensitive Devices

This product has a Moisture Sensitive Level 3 rating per JEDEC J-STD-020. Refer to Broadcom Application Note AN5305, *Handling of Moisture Sensitive Surface Mount Devices*, for additional details and a review of proper handling procedures.

- Before use
 - An unopened moisture barrier bag (MBB) can be stored at $< 40^{\circ}\text{C}/90\% \text{RH}$ for 12 months. If the actual shelf life has exceeded 12 months and the humidity indicator card (HIC) indicates that baking is not required, it is safe to reflow the LEDs per the original MSL rating.
 - Do not open the MBB prior to assembly (such as for IQC).
- Control after opening the MBB
 - Read the HIC immediately upon opening of an MBB.
 - The LEDs must be kept at $< 30^{\circ}\text{C}/60\% \text{RH}$ at all times and all high temperature related processes, including soldering, curing or rework, must be completed within 168 hours.
- Control for unfinished reel

Store unused LEDs in a sealed MBB with desiccant or desiccator at $< 5\% \text{RH}$.
- Control of assembled boards

If the PCB soldered with the LEDs is to be subjected to other high temperature processes, store the PCB in a sealed MBB with desiccant or desiccator at $< 5\% \text{RH}$ to ensure that all LEDs have not exceeded their floor life of 168 hours.
- Baking is required if:
 - The HIC indicator is not BROWN at 10% and is AZURE at 5%.
 - The LEDs are exposed to condition of $> 30^{\circ}\text{C}/60\% \text{RH}$ at any time.
 - The LED floor life exceeded 168 hours.
 - The recommended baking condition is: $60^{\circ}\text{C} \pm 5^{\circ}\text{C}$ for 20 hours.
 - Baking should only be done once.
- Storage

The soldering terminals of these Broadcom LEDs are silver plated. If the LEDs are exposed in ambient environments for too long, the silver plating might be oxidized, thus affecting its solderability performance. As such, keep unused LEDs in a sealed MBB with desiccant or in desiccator at $< 5\% \text{RH}$.

Application Precautions

- The drive current of the LED must not exceed the maximum allowable limit across temperature as stated in the data sheet. Constant current driving is recommended to ensure consistent performance.
- LED is not intended for reverse bias. Use other appropriate components for such purposes. When driving the LED in matrix form, ensure that the reverse bias voltage does not exceed the allowable limit of the LED.
- Do not use the LED in the vicinity of material with sulfur content, in environments of high gaseous sulfur compound and corrosive elements. Examples of materials that may contain sulfur are rubber gaskets, RTV (room temperature vulcanizing) silicone rubber, rubber gloves, and so on. Prolonged exposure to such environments may affect the optical characteristics and product life.
- Avoid rapid changes in ambient temperature, especially in high humidity environment, as this will cause condensation on the LED.
- Although the LED is rated as IPx6 according to IEC60529: Degree of protection provided by enclosure, the test condition may not represent actual exposure during application. If the LED is intended to be used in outdoor or harsh environments, protect the LED against damages caused by rain water, dust, oil, corrosive gases, external mechanical stress, and so on.

Thermal Management

Optical, electrical, and reliability characteristics of LED are affected by temperature. The junction temperature (T_J) of the LED must be kept below allowable limit at all times. T_J can be calculated as follows:

$$T_J = T_A + R_{\theta J-A} \times I_F \times V_{Fmax}$$

where;

T_A = Ambient temperature ($^{\circ}\text{C}$)

$R_{\theta J-A}$ = Thermal resistance from LED junction to ambient ($^{\circ}\text{C/W}$)

I_F = Forward current (A)

V_{Fmax} = Maximum forward voltage (V)

The complication of using this formula lies in T_A and $R_{\theta J-A}$. Actual T_A is sometimes subjective and hard to determine. $R_{\theta J-A}$ varies from system to system depending on design and is usually not known.

Another way of calculating T_J is by using solder point temperature T_S as follows:

$$T_J = T_S + R_{\theta J-S} \times I_F \times V_{Fmax}$$

where;

T_S = LED solder point temperature as shown in the following figure ($^{\circ}\text{C}$)

$R_{\theta J-S}$ = thermal resistance from junction to solder point ($^{\circ}\text{C/W}$)

Figure 24: T_S Point

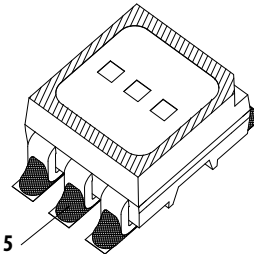

T_S can be measured easily by mounting a thermocouple on the soldering joint as shown in the preceding figure, while $R_{\theta J-S}$ is provided in the data sheet. Verify the T_S of the LED in the final product to ensure that the LEDs are operated within all maximum ratings stated in the data sheet.

Eye Safety Precautions

LEDs may pose optical hazards when in operation. Do not look directly at operating LEDs as it may be harmful to the eyes. For safety reasons, use appropriate shielding or personal protective equipment.

Disclaimer

Broadcom's products are not specifically designed, manufactured, or authorized for sale as parts, components, or assemblies for the planning, construction, maintenance, or direct operation of a nuclear facility or for use in medical devices or applications. The customer is solely responsible, and waives all rights to make claims against Broadcom or its suppliers, for all loss, damage, expense, or liability in connection with such use.

Broadcom, the pulse logo, Connecting everything, Avago Technologies, Avago, and the A logo are among the trademarks of Broadcom and/or its affiliates in the United States, certain other countries, and/or the EU.

Copyright © 2014–2018 Broadcom. All Rights Reserved.

The term "Broadcom" refers to Broadcom Inc. and/or its subsidiaries. For more information, please visit www.broadcom.com.

Broadcom reserves the right to make changes without further notice to any products or data herein to improve reliability, function, or design. Information furnished by Broadcom is believed to be accurate and reliable. However, Broadcom does not assume any liability arising out of the application or use of this information, nor the application or use of any product or circuit described herein, neither does it convey any license under its patent rights nor the rights of others.

