

ARX3A0 - CSP35



ARX3A0 - CSP35 Evaluation Board User's Manual

ON Semiconductor®

www.onsemi.com

Evaluation Board Overview

The evaluation boards are designed to demonstrate the features of ON Semiconductor's image sensors products. This headboard is intended to plug directly into the Demo3 system. Test points and jumpers on the board provide access to the clock, I/Os and other miscellaneous signals.

Features

- Clock Input
 - ◆ Default – 27 MHz Crystal Oscillator
 - ◆ Optional Demo3 Controlled MClk
- Two Wire Serial Interface
 - ◆ Selectable Base Address
- 2 Lane MIPI Interface
- RoHS Compliant

EVAL BOARD USER'S MANUAL



Figure 1. ARX3A0 Evaluation Board

Block Diagram

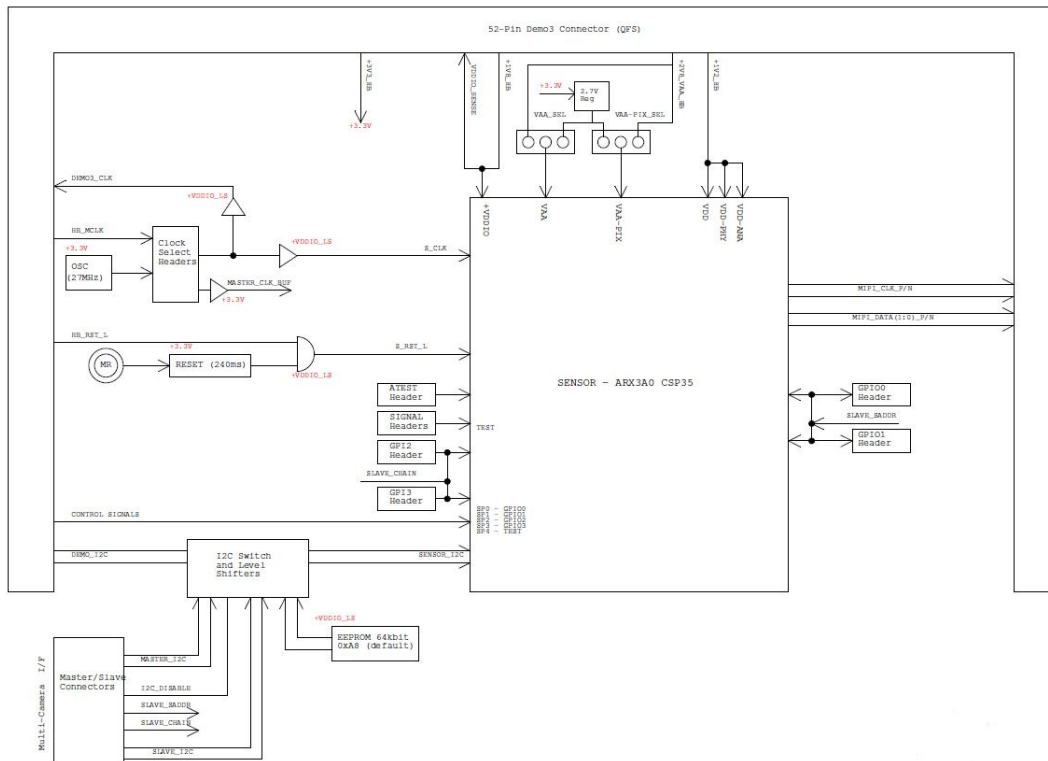

Figure 2. Block Diagram of ARX3A0 Evaluation Board

ARX3A0 – CSP35

Top View

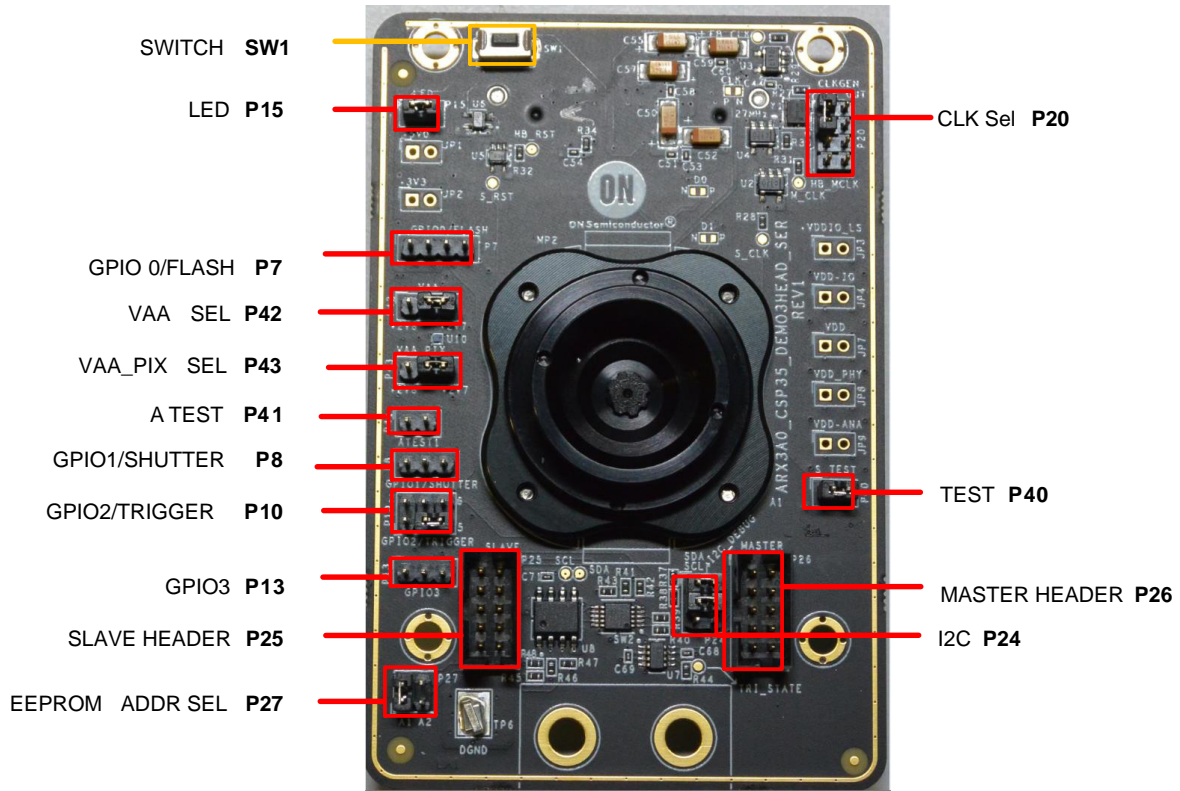

Figure 3. Top View of Evaluation Board – Default Jumpers

Bottom View

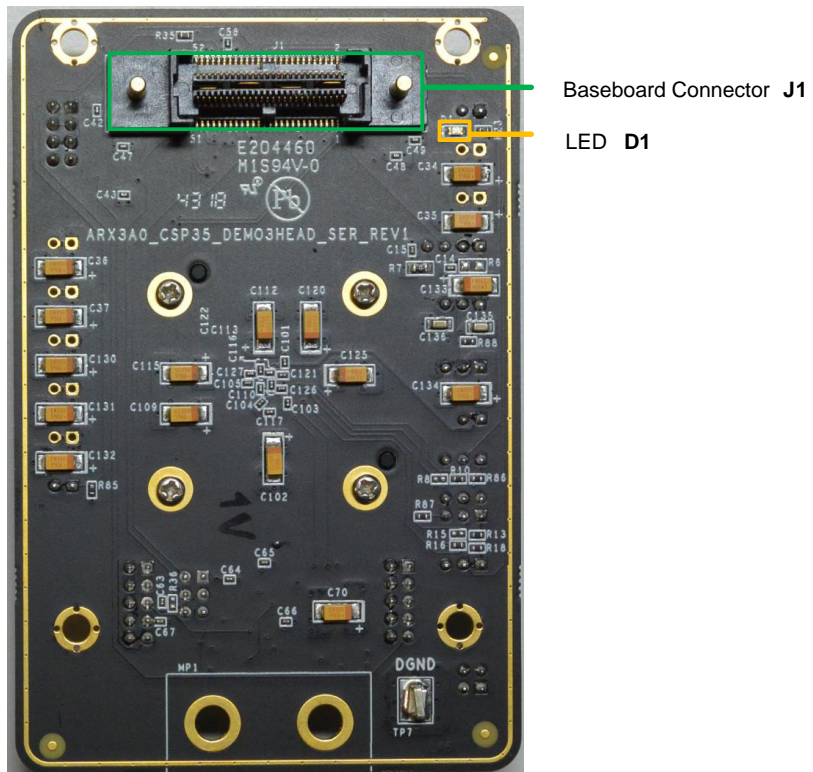

Figure 4. Bottom View of the Evaluation Board – Connector

ARX3A0 – CSP35

Jumper Locations

The jumpers on headboards start with Pin 1 on the leftmost side of the pin. Grouped jumpers increase in pin size with each jumper added.



**Figure 5. Pin Locations for a Single Jumper.
Pin 1 is Located at the Leftmost Side and Increases as it Moves to the Right**

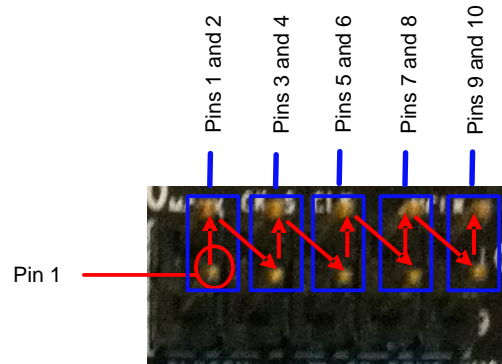

**Figure 6. Pin Locations and Assignments of Grouped Jumpers.
Pin 1 is Located at the Bottom–Left Corner and Increases in a Zigzag Fashion Shown in the Picture (P10 and P27)**

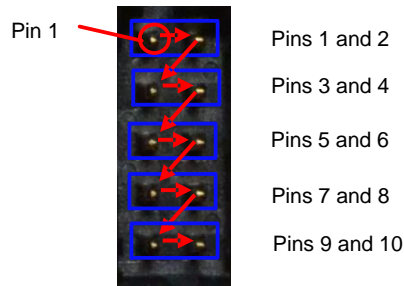

**Figure 7. Pin Locations and Assignments of Grouped Jumpers.
Pin 1 is Located at the Top–Left Corner and Increases in a Zigzag Fashion Shown in the Picture (P20, P24, P25 and P26)**

ARX3A0 – CSP35

Jumper/Header Functions & Default Positions

Table 1. JUMPERS AND HEADERS

Jumper/Header No.	Jumper/Header Name	Pins	Description
P7	GPIO0/FLASH	Open (Default)	
		1	+5V0
		2	GND
		3	GPIO0/FLASH
		4	+3V3
P8	SHUTTER / GPIO1	Open (Default)	Normal Operation
		1–2	Pulled Up
		2–3	Pulled low
P10	GPIO2/TRIGGER	3–5 (Default)	GPIO2 Pull Down
		1–3	GPIO2 Pull Up
		2–4	Trigger from Demo3
		Pin 4	Function Generator Input
P13	GPIO3	Open (default)	Normal Operation / Multi-Camera Slave Mode
		1–2	GPIO3 Pulled up
		2–3	GPIO3 Pulled down / Master Mode
P15	LED	1–2 (Default)	Power LED ON
		Open	Power LED OFF
P20	CLK Selection	1–3 (Default)	Select on-board oscillator clock & enable master clock output
		2–4	Select Slave clock (for slave sensor in multi-camera mode)
		3–5	Select Demo3 clock
		6–8	Enable Master clock (to support slave sensor in multi-camera mode)
P24	I ² C	1–2 & 3–4 (Default)	Demo3 SCL & SDA connected to sensor SCL & SDA respectively
P25, P26	Multi Camera (Slave/Master)		Refer schematics for the connection
P27	EEPROM Addr. Sel	1–2 Closed & 3–4 Open (Default)	EEPROM Address set to 0xA8
		1–2 open & 3–4 Open	EEPROM Address set to 0xAC
		1–2 open & 3–4 closed	EEPROM Address set to 0xA4
		1–2 Closed & 3–4 closed	EEPROM Address set to 0xA0
P40	TEST	1–2 (Default)	Normal Mode Operation
		Open	Test Mode
P41	ATEST1	Open (Default)	Normal operation
		Pin 1 & 2	Analog manufacturing test access
P42	VAA Sel	2–3 (Default)	VAA is at 2.7 V from the on board LDO
		1–2	VAA is at 2.8 V from Demo3 Baseboard
P43	VAA-PIX Sel	2–3 (Default)	VAA-PIX is at 2.7 V from the on board LDO
		1–2	VAA-PIX is at 2.8 V from Demo3 Baseboard
SW1	RESET	N/A	When pushed, 240 ms reset signal will be sent to ARX3A0

ARX3A0 – CSP35

Interfacing to ON Semiconductor Demo3 Baseboard

The ON Semiconductor Demo3 baseboard has a similar 52-pin connector P5 which mates with J1 of the headboard. The four mounting holes secure the baseboard and the headboard with spacers and screws.

Shorted Jumpers for Power Measurement

Different supplies to the evaluation board are provided by trace shorted jumper, for any voltage and power measurements. To conduct current measurement on a given power rail, cut the trace between the two pins of their respective JP, and insert an ammeter prior to powering up the system. The figure below shows where the trace to cut is located.

Table 2. SHORTED JUMPERS FOR POWER MEASUREMENT

Jumper	Voltage (V)
JP1 (From Demo3)	5.0
JP2 (Peripheral 3.3V)	3.3
JP3 (VDDIO_LS)	1.8
JP4 (VDDIO)	1.8
JP7 (VDD)	1.2
JP8 (VDD-PHY)	1.2
JP9 (VDD-ANA)	1.2
P42 (VAA)	2.7
P43 (VAA-PIX)	2.7

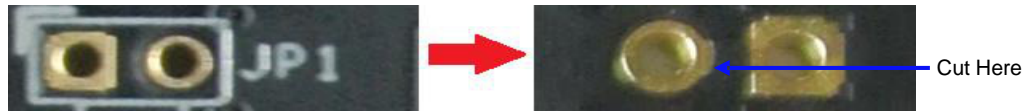

**Figure 8. Top and Bottom View of Shorted Jumper.
The Bottom View Shows the Trace Location to Cut for Current Measurement.**

onsemi, **Onsemi**, and other names, marks, and brands are registered and/or common law trademarks of Semiconductor Components Industries, LLC dba "**onsemi**" or its affiliates and/or subsidiaries in the United States and/or other countries. **onsemi** owns the rights to a number of patents, trademarks, copyrights, trade secrets, and other intellectual property. A listing of **onsemi**'s product/patent coverage may be accessed at www.onsemi.com/site/pdf/Patent-Marking.pdf. **onsemi** is an Equal Opportunity/Affirmative Action Employer. This literature is subject to all applicable copyright laws and is not for resale in any manner.

The evaluation board/kit (research and development board/kit) (hereinafter the "board") is not a finished product and is not available for sale to consumers. The board is only intended for research, development, demonstration and evaluation purposes and will only be used in laboratory/development areas by persons with an engineering/technical training and familiar with the risks associated with handling electrical/mechanical components, systems and subsystems. This person assumes full responsibility/liability for proper and safe handling. Any other use, resale or redistribution for any other purpose is strictly prohibited.

THE BOARD IS PROVIDED BY ONSEMI TO YOU "AS IS" AND WITHOUT ANY REPRESENTATIONS OR WARRANTIES WHATSOEVER. WITHOUT LIMITING THE FOREGOING, ONSEMI (AND ITS LICENSORS/SUPPLIERS) HEREBY DISCLAIMS ANY AND ALL REPRESENTATIONS AND WARRANTIES IN RELATION TO THE BOARD, ANY MODIFICATIONS, OR THIS AGREEMENT, WHETHER EXPRESS, IMPLIED, STATUTORY OR OTHERWISE, INCLUDING WITHOUT LIMITATION ANY AND ALL REPRESENTATIONS AND WARRANTIES OF MERCHANTABILITY, FITNESS FOR A PARTICULAR PURPOSE, TITLE, NON-INFRINGEMENT, AND THOSE ARISING FROM A COURSE OF DEALING, TRADE USAGE, TRADE CUSTOM OR TRADE PRACTICE.

onsemi reserves the right to make changes without further notice to any board.

You are responsible for determining whether the board will be suitable for your intended use or application or will achieve your intended results. Prior to using or distributing any systems that have been evaluated, designed or tested using the board, you agree to test and validate your design to confirm the functionality for your application. Any technical, applications or design information or advice, quality characterization, reliability data or other services provided by **onsemi** shall not constitute any representation or warranty by **onsemi**, and no additional obligations or liabilities shall arise from **onsemi** having provided such information or services.

onsemi products including the boards are not designed, intended, or authorized for use in life support systems, or any FDA Class 3 medical devices or medical devices with a similar or equivalent classification in a foreign jurisdiction, or any devices intended for implantation in the human body. You agree to indemnify, defend and hold harmless **onsemi**, its directors, officers, employees, representatives, agents, subsidiaries, affiliates, distributors, and assigns, against any and all liabilities, losses, costs, damages, judgments, and expenses, arising out of any claim, demand, investigation, lawsuit, regulatory action or cause of action arising out of or associated with any unauthorized use, even if such claim alleges that **onsemi** was negligent regarding the design or manufacture of any products and/or the board.

This evaluation board/kit does not fall within the scope of the European Union directives regarding electromagnetic compatibility, restricted substances (RoHS), recycling (WEEE), FCC, CE or UL, and may not meet the technical requirements of these or other related directives.

FCC WARNING – This evaluation board/kit is intended for use for engineering development, demonstration, or evaluation purposes only and is not considered by **onsemi** to be a finished end product fit for general consumer use. It may generate, use, or radiate radio frequency energy and has not been tested for compliance with the limits of computing devices pursuant to part 15 of FCC rules, which are designed to provide reasonable protection against radio frequency interference. Operation of this equipment may cause interference with radio communications, in which case the user shall be responsible, at its expense, to take whatever measures may be required to correct this interference.

onsemi does not convey any license under its patent rights nor the rights of others.

LIMITATIONS OF LIABILITY: **onsemi** shall not be liable for any special, consequential, incidental, indirect or punitive damages, including, but not limited to the costs of requalification, delay, loss of profits or goodwill, arising out of or in connection with the board, even if **onsemi** is advised of the possibility of such damages. In no event shall **onsemi**'s aggregate liability from any obligation arising out of or in connection with the board, under any theory of liability, exceed the purchase price paid for the board, if any.

The board is provided to you subject to the license and other terms per **onsemi**'s standard terms and conditions of sale. For more information and documentation, please visit www.onsemi.com.

PUBLICATION ORDERING INFORMATION

LITERATURE FULFILLMENT:

Email Requests to: orderlit@onsemi.com

onsemi Website: www.onsemi.com

TECHNICAL SUPPORT

North American Technical Support:

Voice Mail: 1 800-282-9855 Toll Free USA/Canada

Phone: 011 421 33 790 2910

Europe, Middle East and Africa Technical Support:

Phone: 00421 33 790 2910

For additional information, please contact your local Sales Representative