

Silicon Photomultipliers (SiPM), RDM-Series 1 x 16 Monolithic Array



ON Semiconductor®

www.onsemi.com

Product Preview

ArrayRDM-0116A10-DFN

The ArrayRDM-0116A10-DFN is a monolithic 1 × 16 array of Silicon Photomultiplier (SiPM) pixels based on the market-leading RDM process. The RDM process has been specifically developed to create products that give high PDE at the NIR wavelengths used for LiDAR and 3D ranging applications. The ArrayRDM-0116A10-DFN also features an anti-reflection coating on the entrance window.

In order to meet the requirements for automotive LiDAR applications, this product is qualified to the AEC-Q102 standard and developed in accordance with IATF 16949.

An evaluation board (ArrayRDM-0116A10-GEVB) is also available for this product.

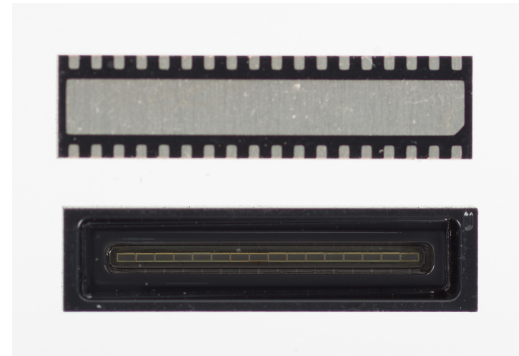

The ARRAYRDM-0116A10-DFN Product

KEY SENSOR AND PACKAGE SPECIFICATIONS

Parameter	Value	Comment
Silicon Process	RDM	
Number of Pixels	16	
Array Configuration	1 × 16	
Pixel Size	0.17 × 0.49 mm	
Pixel Pitch	0.55 mm	
Microcell Size	10 μm	
Number of Microcells per Pixel	368	
Package Size	3 × 12 × 1.85 mm	DFN Package (W × L × H)
Output Type	Analog	Standard and Fast Output per Pixel

PERFORMANCE SPECIFICATIONS

Typical values are measured at 21°C. Minimum and Maximum (when available) values take into account operation over the full temperature range of -40°C to 105°C. All measurements made at V_{br} + 19 V. Note that V_{ov} and values below may change in the final product.

Parameter	Min	Typ	Max	Unit	Comment
PDE @ 905 nm	-	14	-	%	
Dark Count Rate	-	40	-	kcps	Per pixel
Optical Crosstalk	-	25	-	%	
Gain	-	0.8 × 10 ⁶	-		
Afterpulsing Probability	-	TBD	-		
Microcell Recovery Time	-	18	-	ns	RC time constant
Microcell Rise Time	-	0.25	-	ns	
Fast Output Pulse Width	-	1	-	ns	
Fast Output Rise Time	-	0.25	-	ns	
Terminal Capacitance	-	59	-	pF	Per pixel

This document contains information on a product under development. ON Semiconductor reserves the right to change or discontinue this product without notice.

ArrayRDM-0116A10-DFN

BIAS PARAMETERS

Parameter	Min	Typ	Max	Unit	Comment
Breakdown Voltage (Vbr)	–	21.7	–	V	See Figure 1 for plot of typical Vbr as a function of temperature
Over Voltage (Vov)	–	19.0	–	V	Typical value recommended for operation and used for characterization
Operating Bias (Vop)	Vop = Vbr + Vov				
Temperature Coefficient of Vbr	See Figure 1			mV/°C	

ABSOLUTE MAXIMUM RATINGS

Parameter	Value	Unit	Comment
Maximum Bias	45 V	V	
Maximum Current	14 mA	mA	For the whole array at 40.7 V (Vop) and 21°C
Maximum Storage Temperature	125	°C	
Operating Temperature Range	–40 to +105	°C	Ambient temperature

Stresses exceeding those listed in the Maximum Ratings table may damage the device. If any of these limits are exceeded, device functionality should not be assumed, damage may occur and reliability may be affected.

PACKAGE SPECIFICATIONS

Parameter	Value	Unit	Comment
ESD-HBM	TBD		
ESD-CDM	TBD		
θ_{JC}	4	°C/W	
θ_{JA}	245	°C/W	
MSL	3		For all part numbers

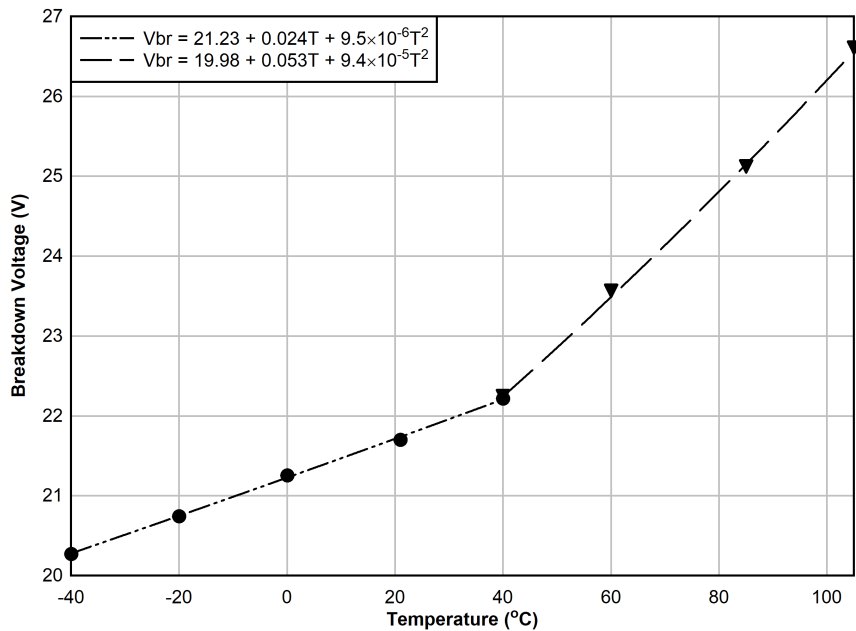

Figure 1. Breakdown Voltage vs. Temperature

ArrayRDM-0116A10-DFN

BIAS AND READOUT RECOMMENDATIONS

The ArrayRDM-0116A10-DFN is formed of a linear array of 16 SiPM pixels and housed in a 36-pin DFN package. Figure 2 shows the sensor array schematic. The signals from each pixel can be accessed either via the pixel cathode or fast output. The common anode is also available and allows the provision of a single bias supply for all 16 pixels.

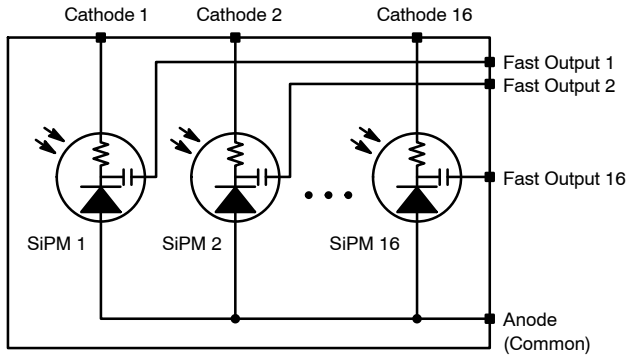

Figure 2. Array Schematic Showing Pixel Connections

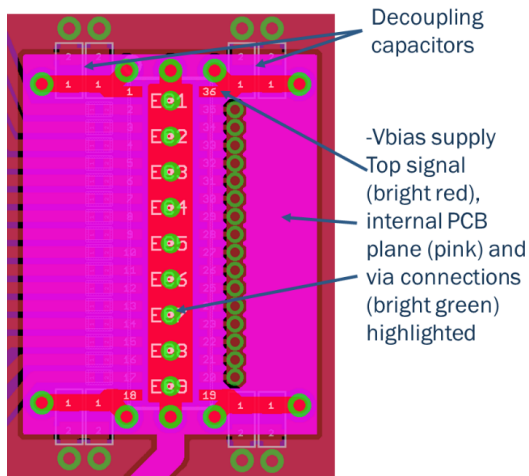

Figure 3.

The following recommendations for the bias are advised (see Figure 3):

- Supply negative bias to the anode with cathode terminated to GND as illustrated in EVB schematic in Figure 6
- Use an internal power plane below the GND plane for the bias
- Place decoupling capacitors close to anode corner pins of the DFN (pins 1, 18, 19 & 36)

- ♦ Pairs of 1 nF 100 V ceramic capacitors are recommended for systems where dynamic switching of bias is required
- ♦ Higher capacitance can be used when static bias voltage is used eg 10 nF 100 V
- Use the EPAD contact to reduce the inductance of the bias supply connection to the SiPM array by using multiple plugged vias from the EPAD to the bias plane
- Decoupling capacitors should also be used on the back side of the PCB from the EPAD vias to GND when possible

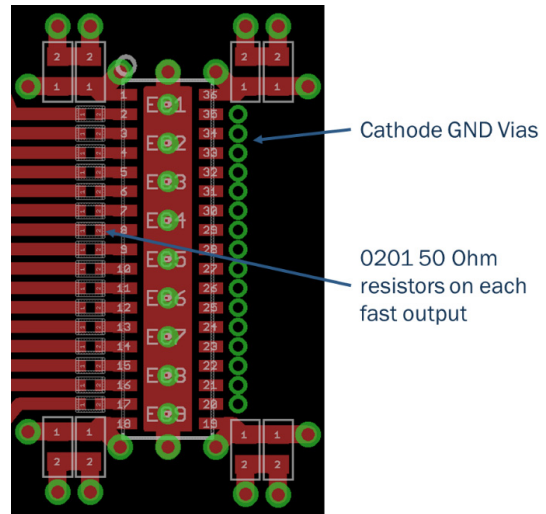

Figure 4.

Recommendations for Series Termination (see Figure 4):

- Use series termination resistors close to the fast output pins (pins 2 to 17) of the Array
 - ♦ Helps to match the source impedance of the SiPM pixels to the PCB and amplifier load
 - ♦ Helps to reduce reflections of the high speed signals
 - ♦ 0201 package size resistors fit neatly beside each fast output pin
- GND cathodes near to each cathode pin (pins 20 to 35) using vias to GND plane when standard readout is not required
- Terminate any unused fast outputs using 50 Ω resistor to GND to avoid further reflections from unterminated tracks

Recommendations for Signal Track Impedance:

- Match impedance of signal tracks to 50 Ω
- E.g. Use microstrip impedance where signals on the top layer of the PCB are above a ground plane on an internal layer of the PCB

ArrayRDM-0116A10-DFN

PIN ASSIGNMENT

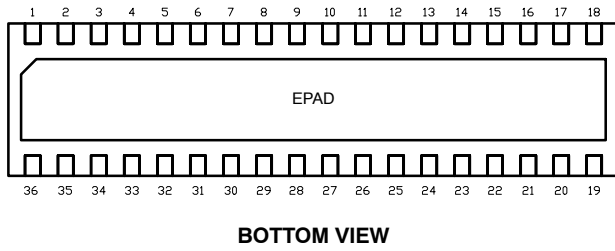
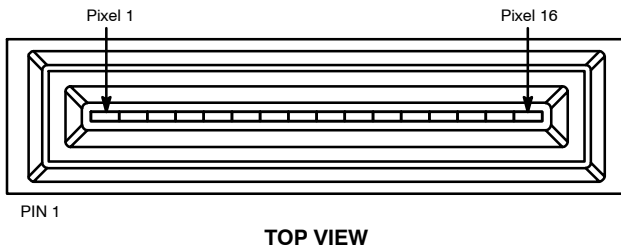

Pin #	Pin Assignment	Pin #	Pin Assignment
1	Anode	19	Anode
2	Fast output 1	20	Cathode 16
3	Fast output 2	21	Cathode 15
4	Fast output 3	22	Cathode 14
5	Fast output 4	23	Cathode 13
6	Fast output 5	24	Cathode 12
7	Fast output 6	25	Cathode 11
8	Fast output 7	26	Cathode 10
9	Fast output 8	27	Cathode 9
10	Fast output 9	28	Cathode 8
11	Fast output 10	29	Cathode 7
12	Fast output 11	30	Cathode 6
13	Fast output 12	31	Cathode 5
14	Fast output 13	32	Cathode 4
15	Fast output 14	33	Cathode 3
16	Fast output 15	34	Cathode 2
17	Fast output 16	35	Cathode 1
18	Anode	36	Anode
EPAD	Anode		

ArrayRDM-0116A10-DFN

EVALUATION BOARD

The ArrayRDM-0116A10-GEVB evaluation board is shown in Figure 5 and schematically (with pin outs) in Figure 6. It consists of:

- ArrayRDM-0116A10-DFN 16-channel SiPM array
- 32 U.FL connectors for access to each pixel cathode and fast output for signal readout
- An SMA connector for applying the bias to the common anode
- Bias filtering circuit
- Decoupling capacitors (14 x 10 nF and 4 x 100 nF decoupling capacitors from anode to ground – not shown)

This product allows a user to quickly and easily set up an evaluation of the array product.

Note that a negative bias supply should be supplied via the SMA connector (J33), and the U.FL connectors (J1 to J32) should be 50 Ω terminated.

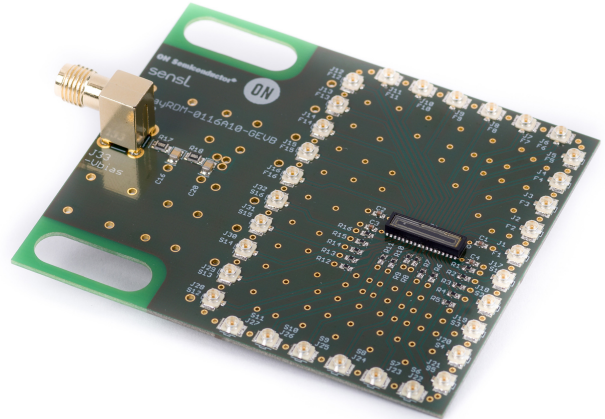
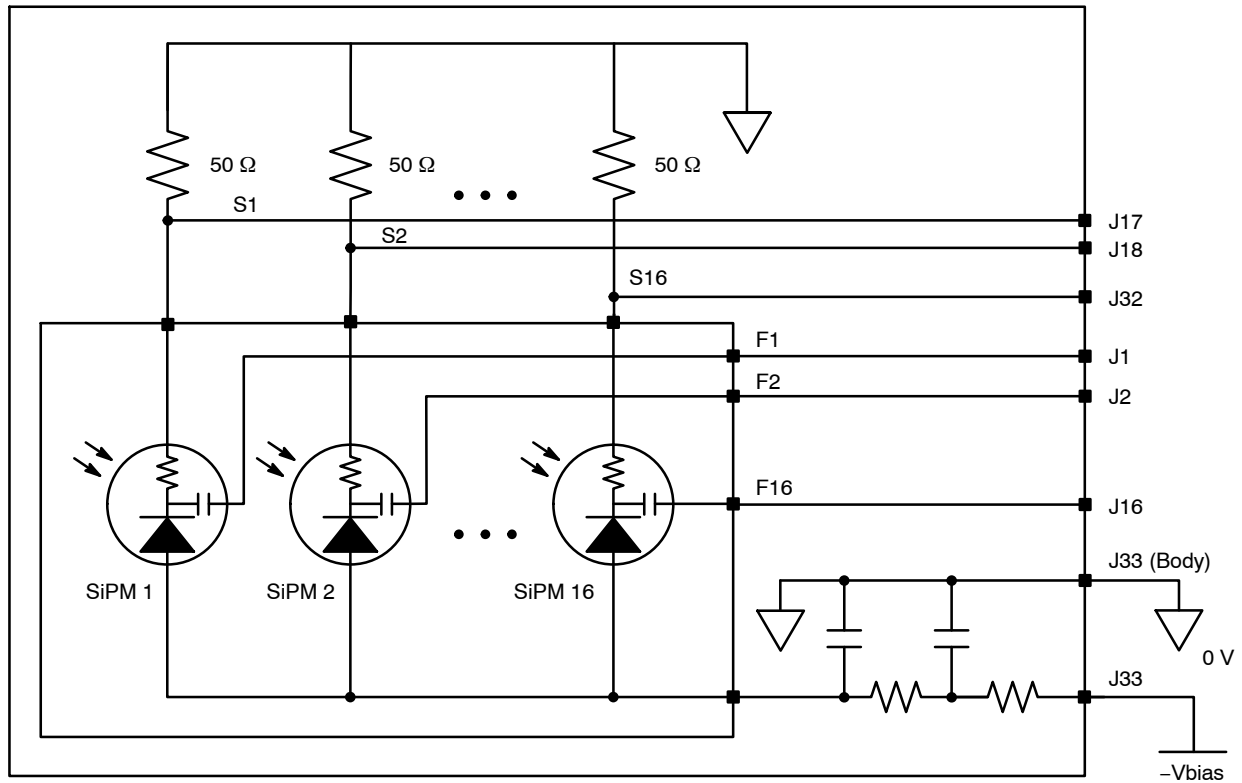

Figure 5. ArrayRDM-0116A10-GEVB Top Side View Showing the 1x16 Sensor Placement



Connector	Style
J1-J32	U.FL Receptacle (Hirose U.FL-R-SMT)
J33	SMA Jack (F)

Figure 6. ArrayRDM-0116A10-GEVB Board Schematic

ArrayRDM-0116A10-DFN

ORDERING INFORMATION

Part Number	Product Description	Shipping Format†
ArrayRDM-0116A10-DFN-TR	Monolithic 1 × 16 array of NIR sensitive SiPM pixels formed using the RDM process. Individual cathode and fast output connection per pixel and a common anode available via the 36-pin DFN package.	Tape and Reel
ArrayRDM-0116A10-DFN-TR1		Cut Tape
ArrayRDM-0116A10-DFN-TR-E	Unqualified prototype part of the ArrayRDM-0116A10-DFN-TR	Depends on Quantity Order
ArrayRDM-0116A10-GEVB	Evaluation board consisting of an ArrayRDM-0116A10-DFN mounted onto PCB. A U.FL connector gives access to each pixel cathode and fast output. The bias is supplied via an SMA connector to the common anode.	ESD Package

†For information on tape and reel specifications, including part orientation and tape sizes, please contact sensl_questions@onsemi.com.

ArrayRDM-0116A10-DFN

PACKAGE DIMENSIONS

DFN36 12x3, 0.65P
CASE 506EV
ISSUE O

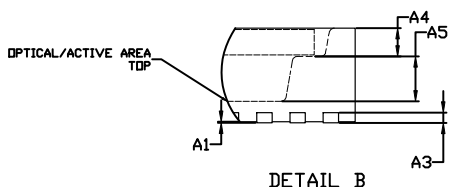
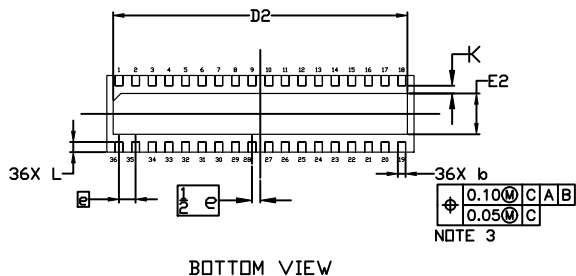
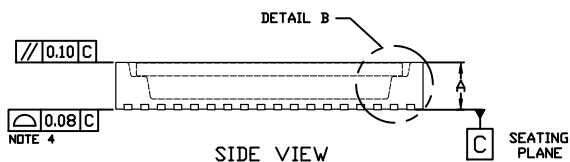
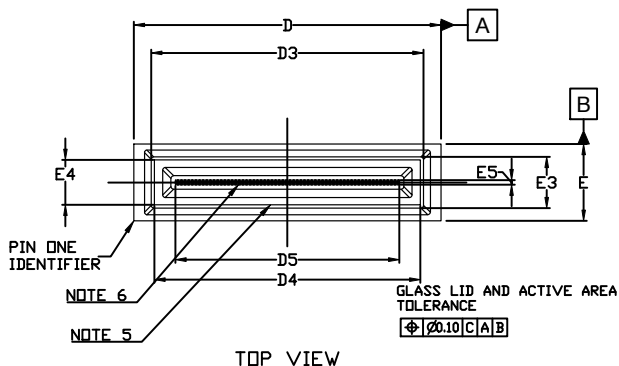

NOTES:

1. DIMENSIONING AND TOLERANCING PER ASME Y14.5M, 2009.
2. CONTROLLING DIMENSION: MILLIMETERS
3. DIMENSION *b* APPLIES TO PLATED TERMINAL AND IS MEASURED BETWEEN 0.15 AND 0.30 MM FROM THE TERMINAL TIP.
4. COPLANARITY APPLIES TO THE EXPOSED PAD AS WELL AS THE TERMINALS.
5. GLASS LID AREA, 0.5mm THICKNESS. DEFINED BY D4 & E4.
6. OPTICAL/ACTIVE AREA IS CENTERED.

DIM	MILLIMETERS			DIM	MILLIMETERS		
	MIN.	NDM.	MAX.		MIN.	NDM.	MAX.
A	1.75	1.85	1.95	E	2.90	3.00	3.10
A1	0.00	---	0.05	E2	1.50	1.60	1.70
A3	0.203 REF			E3	2.00 REF		
A4	0.550 REF			E4	1.75 REF		
A5	0.877 REF			E5	0.18 REF		
<i>b</i>	0.25	0.30	0.35	<i>e</i>	0.65 BSC		
D	11.90	12.00	12.10	K	0.10	---	---
D2	11.40	11.50	11.60	L	0.35	0.40	0.45
D3	10.65 REF						
D4	10.40 REF						
D5	8.75 REF						

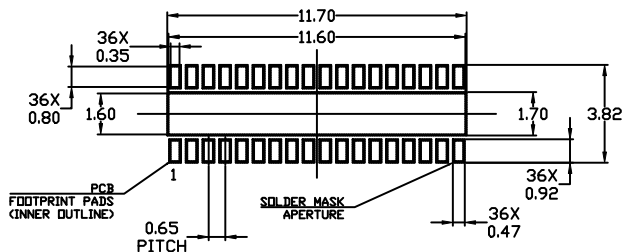

- For additional information on our Pb-Free strategy and soldering details, please download the ON Semiconductor Soldering and Mounting Techniques Reference Manual, SOLDERM/D.

ArrayRDM-0116A10-DFN

EVALUATION BOARD DIMENSIONS

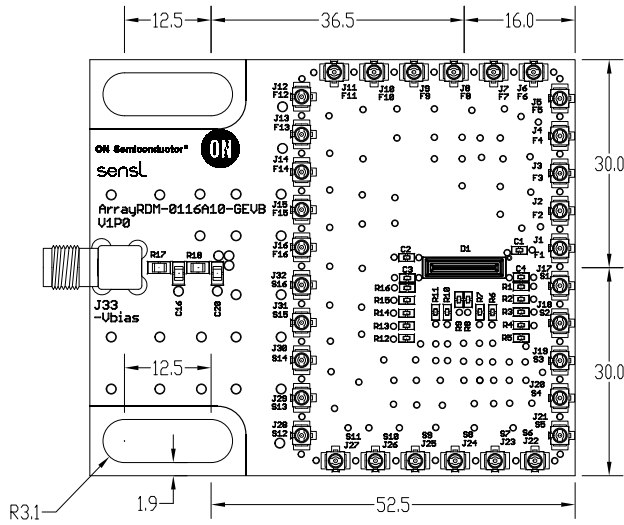

Front View

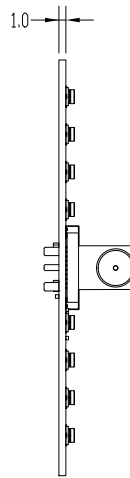

Side View

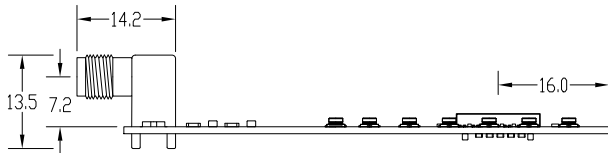

Side View

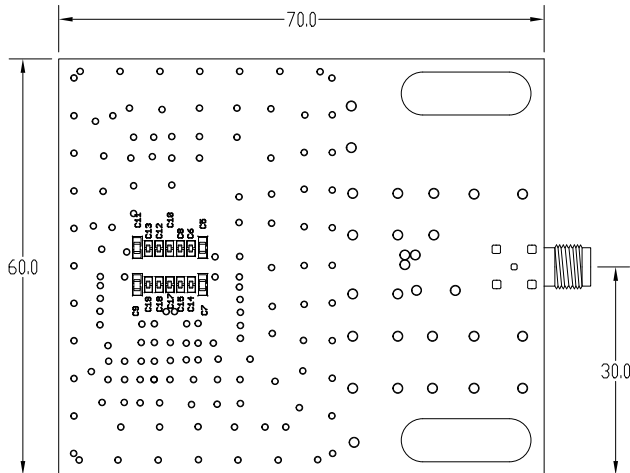

Back View

Connector	Signal Name	Description	Connector	Signal Name	Description
J1	F1	Fast Output 1	J17	S1	Standard Output 1
J2	F2	Fast Output 2	J18	S2	Standard Output 2
J3	F3	Fast Output 3	J19	S3	Standard Output 3
J4	F4	Fast Output 4	J20	S4	Standard Output 4
J5	F5	Fast Output 5	J21	S5	Standard Output 5
J6	F6	Fast Output 6	J22	S6	Standard Output 6
J7	F7	Fast Output 7	J23	S7	Standard Output 7
J8	F8	Fast Output 8	J24	S8	Standard Output 8
J9	F9	Fast Output 9	J25	S9	Standard Output 9
J10	F10	Fast Output 10	J26	S10	Standard Output 10
J11	F11	Fast Output 11	J27	S11	Standard Output 11
J12	F12	Fast Output 12	J28	S12	Standard Output 12
J13	F13	Fast Output 13	J29	S13	Standard Output 13
J14	F14	Fast Output 14	J30	S14	Standard Output 14
J15	F15	Fast Output 15	J31	S15	Standard Output 15
J16	F16	Fast Output 16	J32	S16	Standard Output 16
			J33	-Vbias	Negative Bias Supply

Pinout Table

ArrayRDM-0116A10-DFN

SensL is a registered trademark of Semiconductor Components Industries, LLC (SCILLC) or its subsidiaries in the United States and/or other countries. All other brand names and product names appearing in this document are registered trademarks or trademarks of their respective holders.

ON Semiconductor and  are trademarks of Semiconductor Components Industries, LLC dba ON Semiconductor or its subsidiaries in the United States and/or other countries. ON Semiconductor owns the rights to a number of patents, trademarks, copyrights, trade secrets, and other intellectual property. A listing of ON Semiconductor's product/patent coverage may be accessed at www.onsemi.com/site/pdf/Patent-Marking.pdf. ON Semiconductor reserves the right to make changes without further notice to any products herein. ON Semiconductor makes no warranty, representation or guarantee regarding the suitability of its products for any particular purpose, nor does ON Semiconductor assume any liability arising out of the application or use of any product or circuit, and specifically disclaims any and all liability, including without limitation special, consequential or incidental damages. Buyer is responsible for its products and applications using ON Semiconductor products, including compliance with all laws, regulations and safety requirements or standards, regardless of any support or applications information provided by ON Semiconductor. "Typical" parameters which may be provided in ON Semiconductor data sheets and/or specifications can and do vary in different applications and actual performance may vary over time. All operating parameters, including "Typicals" must be validated for each customer application by customer's technical experts. ON Semiconductor does not convey any license under its patent rights nor the rights of others. ON Semiconductor products are not designed, intended, or authorized for use as a critical component in life support systems or any FDA Class 3 medical devices or medical devices with a same or similar classification in a foreign jurisdiction or any devices intended for implantation in the human body. Should Buyer purchase or use ON Semiconductor products for any such unintended or unauthorized application, Buyer shall indemnify and hold ON Semiconductor and its officers, employees, subsidiaries, affiliates, and distributors harmless against all claims, costs, damages, and expenses, and reasonable attorney fees arising out of, directly or indirectly, any claim of personal injury or death associated with such unintended or unauthorized use, even if such claim alleges that ON Semiconductor was negligent regarding the design or manufacture of the part. ON Semiconductor is an Equal Opportunity/Affirmative Action Employer. This literature is subject to all applicable copyright laws and is not for resale in any manner.

PUBLICATION ORDERING INFORMATION

LITERATURE FULFILLMENT:

Email Requests to: orderlit@onsemi.com

ON Semiconductor Website: www.onsemi.com

TECHNICAL SUPPORT

North American Technical Support:
Voice Mail: 1 800-282-9855 Toll Free USA/Canada
Phone: 011 421 33 790 2910

Europe, Middle East and Africa Technical Support:
Phone: 00421 33 790 2910

For additional information, please contact your local Sales Representative