

Thank you for your interest in **onsemi** products.
Your technical document begins on the following pages.



Your Feedback is Important to Us!

Please take a moment to participate in our short survey.
At **onsemi**, we are dedicated to delivering technical content that best meets your needs.

[Help Us Improve – Take the Survey](#)

This survey is intended to collect your feedback, capture any issues you may encounter, and to provide improvements you would like to suggest.

We look forward to your feedback.

To learn more about **onsemi**, please visit our website at
www.onsemi.com

onsemi and **onsemi** and other names, marks, and brands are registered and/or common law trademarks of Semiconductor Components Industries, LLC dba "**onsemi**" or its affiliates and/or subsidiaries in the United States and/or other countries. **onsemi** owns the rights to a number of patents, trademarks, copyrights, trade secrets, and other intellectual property. A listing of **onsemi** product/patent coverage may be accessed at www.onsemi.com/site/pdf/Patent-Marking.pdf. **onsemi** reserves the right to make changes at any time to any products or information herein, without notice. The information herein is provided "as-is" and **onsemi** makes no warranty, representation or guarantee regarding the accuracy of the information, product features, availability, functionality, or suitability of its products for any particular purpose, nor does **onsemi** assume any liability arising out of the application or use of any product or circuit, and specifically disclaims any and all liability, including without limitation special, consequential or incidental damages. Buyer is responsible for its products and applications using **onsemi** products, including compliance with all laws, regulations and safety requirements or standards, regardless of any support or applications information provided by **onsemi**. "Typical" parameters which may be provided in **onsemi** data sheets and/or specifications can and do vary in different applications and actual performance may vary over time. All operating parameters, including "Typicals" must be validated for each customer application by customer's technical experts. **onsemi** does not convey any license under any of its intellectual property rights nor the rights of others. **onsemi** products are not designed, intended, or authorized for use as a critical component in life support systems or any FDA Class 3 medical devices or medical devices with a same or similar classification in a foreign jurisdiction or any devices intended for implantation in the human body. Should Buyer purchase or use **onsemi** products for any such unintended or unauthorized application, Buyer shall indemnify and hold **onsemi** and its officers, employees, subsidiaries, affiliates, and distributors harmless against all claims, costs, damages, and expenses, and reasonable attorney fees arising out of, directly or indirectly, any claim of personal injury or death associated with such unintended or unauthorized use, even if such claim alleges that **onsemi** was negligent regarding the design or manufacture of the part. **onsemi** is an Equal Opportunity/Affirmative Action Employer. This literature is subject to all applicable copyright laws and is not for resale in any manner. Other names and brands may be claimed as the property of others.

1/1.8-inch 20 MP CMOS Digital Image Sensor

AR2020

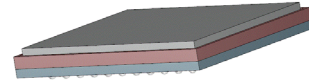

PBGA78 13x10.5
CASE 117CV

General Description

The **onsemi** AR2020 is a stacked 1/1.8-inch back side illuminated (BSI) CMOS active-pixel digital image sensor with a pixel array of 5120H x 3840V (5136H x 3856V including border pixels). The AR2020 has enhanced NIR response.

It incorporates sophisticated on-chip camera functions such as Wake on Motion (WOM), context switching and multiple subsampling modes. It is programmable through a simple I²C interface and has very low power consumption.

The AR2020 digital image sensor features **onsemi**'s breakthrough low-noise CMOS imaging technology.

The AR2020 sensor can generate full resolution image at up to 60 frames per second (fps) in 10-bit linear mode. AR2020 can achieve 30 fps in line interleaved high dynamic range (LI-HDR) and enhanced Dynamic Range (eDR) modes.

Features

- 20 MP CMOS Sensor with Advanced 1.4 μm Pixel Stacked BSI Technology
- Enhanced NIR Response at 850 nm and 940 nm Wavelength
- LI-HDR: Supports Line Interleaved T1/T2 Readout to Enable HDR Processing in ISP Chip
- enhanced Dynamic Range (eDR)
- In Sensor Scaler that Supports both Mono and Bayer RGB Version
- Super Low Power Mode (SLP)
- Wake On Motion (WOM)/Motion Detection
- Subsampling Modes: Skipping, Binning, Summing
- Data Interfaces:
 - ◆ MIPI D-PHY – 2x4 Lanes
- Bit-depth Compression Available for MIPI Interface
- I²C Fast Mode+ Serial Interface
- Various Trigger Modes for Multi-sensor Synchronization
- Electronic Rolling Shutter (ERS) and Global Reset Release (GRR) Modes Supported
- Context Switching
- 1952 bytes One-time Programmable Memory (OTPM) for Storing Shading Correction Coefficients and Module Information
- Programmable Controls: Gain, Horizontal and Vertical Blanking, Frame Size/Rate, Exposure, Window Size, Cropping and Mirror and Flip
- On-chip Temperature Sensor with ±5°C accuracy
- On-chip Lens Shading Correction for RGB Bayer and Mono

ORDERING INFORMATION

See detailed ordering and shipping information on page 3 of this data sheet.

Non-NDA Data Sheet

Interested in what you see? If you would like more detailed information, please request the full version of our data sheet.

[Request Full Data Sheet](#)

Applications

- Surveillance Camera
- Video Conferencing
- Machine Vision
- 3D and Stereo Imaging

AR2020

Table 1. KEY PERFORMANCE PARAMETERS

Parameter		Value
Optical format		1/1.8-inch 20 MP (4:3)
Active pixels		5120H x 3840V
Color Filter Array		RGB Bayer, Monochrome
Pixel size		1.4 μm Back Side Illuminated (BSI)
Chief ray angle (CRA)		13°
Input clock frequency		6 – 48 MHz
Interface		2x4-lane MIPI (1x1, 1x2, 1x4, 2x4-lane supported) using D-PHY; Max data rate: 2 Gbps/lane
ADC resolution		10-bits, on die
Frame Rate	Full Size, Linear Mode	60 fps (MIPIx2), 30 fps (MIPIx1)
Gain Control: Gain Table		0–50.79 dB total (Analog 0–22.39 dB, Digital 0–28.4 dB)
Subsampling		Subsampling: Skipping (RGB, Mono), Binning (RGB), Summing (Mono)
Scaler		Adjustable x- and y-scaling up to 32x, with 0.05% accuracy, for Bayer and Mono variant.
SmartROI		Support SmartROI feature that can send out two ROIs over different MIPI Virtual Channels.
Temperature sensor		10-bit, controlled by two-wire serial I/F, $\pm 5^\circ\text{C}$ accuracy
Compression		DPCM: 10–8
3D Support		Frame rate and exposure synchronization
Supply voltage	Analog, Pixel	2.8 V ($2.7 < V_{\text{supply}} < 2.9$ V)
	I/O	1.8 V ($1.7 < V_{\text{supply}} < 1.9$ V)
	Digital, PLL, MIPIphy	1.05 V ($1.0 < V_{\text{supply}} < 1.1$ V)
Power consumption		430 mW (Typical) at (RGB) 20 MP and 60 fps
Responsivity		17.3 ke-/lux-sec (Clear in Mono) 8.7 ke-/lux-sec (Green in RGB)
SNRMAX		39.9 dB
Dynamic Range		73 dB (eDR 1-exp) 100 dB (LI-HDR Mode)
Operating Temperature Range (at junction) – T_J		-30°C to $+85^\circ\text{C}$
Performance Specified Temperature Range (at junction) – T_J		0°C to $+60^\circ\text{C}$
Package Options:		MPBGA-78 (13 mm x 10.5 mm)
θ_{JA} (Note 1)		30°C/W
θ_{JB}		18°C/W

1. θ_{JA} is dependent on the customer module design and should not be used for calculating junction temperature.

AR2020

Table 2. MODES OF OPERATION 10-BIT

Modes	Sensor Resolution	Mode Name	FPS (2x4 MIPI)	FPS (1x4 MIPI)
20M Linear	5120x3840	Native	60	37
20M LI-HDR	5120x3840	Native	30	18
20M LI-eDR	5120x3840	Native	30	15
5M Linear	2560x1920	Bin2	120	120
1280x960 Linear	1280x960	Bin4	240	240
20M SLP Linear	5120x3840	Native	1	1
Wake On Motion (WOM)	640x480	Skip2Bin4	2	2
Wake ON Motion (WOM) w/ streaming	1280x960	Bin4	2	2

NOTE: Contact your **onsemi** Field Applications Engineer for additional modes.

Table 3. MODES OF OPERATION 12-BIT

Modes	Sensor Resolution	Mode Name	FPS (2 x 4 MIPI)	FPS (1 x 4 MIPI)
20M eDR	5120x3840	Native	30	25

NOTE: Contact your **onsemi** Field Applications Engineer for additional modes.

Table 4. ORDERING INFORMATION

Part Number	Product Description	Orderable Product Attribute Description
AR2020CSSC13SMTA0-DP	20 MP 1/1.8" CMOS Image Sensor RGB 13° CRA	mPBGA with Protective Film
AR2020CSSC13SMTA0-DP2	20 MP 1/1.8" CMOS Image Sensor RGB 13° CRA	mPBGA with Protective Film, Small MOQ
AR2020CSSC13SMTAH3-GEVB	20 MP 1/1.8" CMOS Image Sensor RGB 13° CRA	Demo3 Headboard

AR2020CSSM13SMTA0-DP	20 MP 1/1.8" CMOS Image Sensor Mono 13° CRA	mPBGA with Protective Film
AR2020CSSM13SMTA0-DP2	20 MP 1/1.8" CMOS Image Sensor Mono 13° CRA	mPBGA with Protective Film, Small MOQ
AR2020CSSM13SMTAH3-GEVB	20 MP 1/1.8" CMOS Image Sensor Mono 13° CRA	Demo3 Headboard

NOTE: Refer to AR2020 Die Data Sheet for Die Part Numbers & Ordering Information.

AR2020

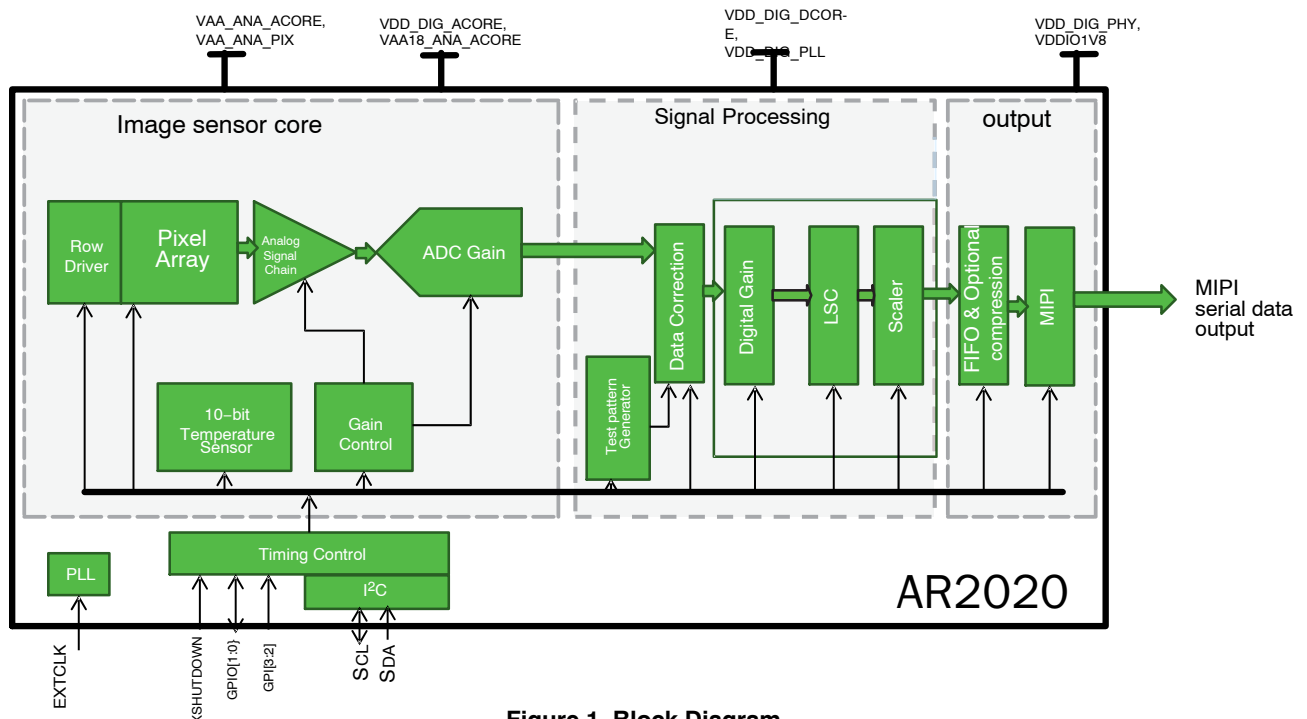
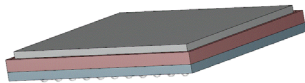
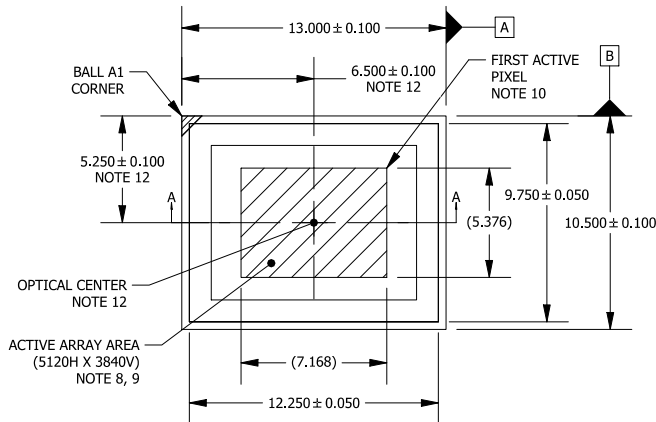

Figure 1. Block Diagram



PBGA78 13x10.5
CASE 117CV
ISSUE O

DATE 28 OCT 2021



TOP VIEW

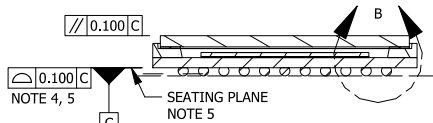

SECTION A-A

NOTES:

1. DIMENSIONING AND TOLERANCING PER ASME Y14.5M, 1994.
2. CONTROLLING DIMENSION: MILLIMETERS [mm].
3. SOLDER BALL DIAMETER IS MEASURED AT THE MAXIMUM SOLDER BALL DIAMETER PARALLEL TO DATUM C.
4. COPLANARITY APPLIES TO THE SPHERICAL CROWNS OF THE SOLDER BALLS.
5. DATUM C, THE SEATING PLANE IS DEFINED BY THE SPHERICAL CROWNS OF THE SOLDER BALLS.
6. GLASS: 0.550 THICKNESS; REFRACTIVE INDEX = 1.52.
7. AIR GAP BETWEEN GLASS AND PIXEL ARRAY: 0.275 THICKNESS.
8. PARALLELISM APPLIES ONLY TO THE ACTIVE ARRAY.
9. MAXIMUM ROTATION OF ACTIVE ARRAY RELATIVE TO DATUMS A AND B IS ± 1°.
10. REFER TO THE DEVICE DATA SHEET FOR TOTAL PIXEL ARRAY DEFINITIONS.
11. PACKAGE CENTER (X, Y) = (0.000, 0.000).
12. OPTICAL CENTER RELATIVE TO PACKAGE CENTER (X, Y) = TBD AS DRAWN (0.000, 0.000).

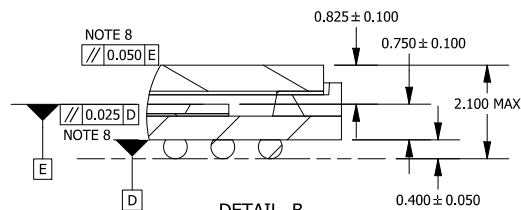

DETAIL B
SCALE 7 : 1

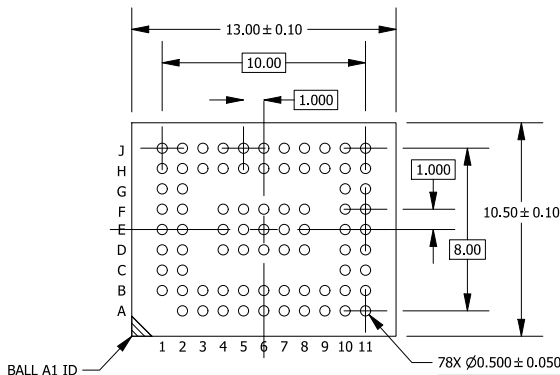

BOTTOM VIEW

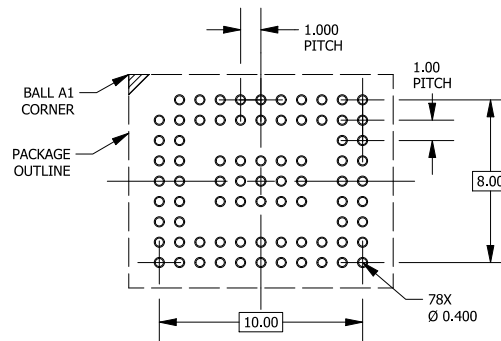

RECOMMENDED MOUNTING FOOTPRINT*

*FOR ADDITIONAL INFORMATION ON OUR Pb-FREE STRATEGY AND SOLDERING DETAILS, PLEASE DOWNLOAD THE ON SEMICONDUCTOR SOLDERING AND MOUNTING TECHNIQUES REFERENCE MANUAL, SOLDERRM/D.

GENERIC MARKING DIAGRAM*

PIN A1 INDICATOR

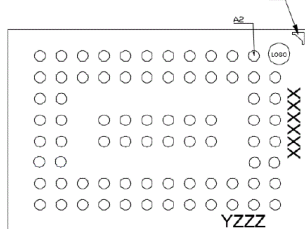

XXXX = Specific Device Code
Y = Year
ZZZ = Lot Traceability

*This information is generic. Please refer to device data sheet for actual part marking. Pb-Free indicator, "G" or microdot "▪", may or may not be present. Some products may not follow the Generic Marking.

DOCUMENT NUMBER:	98AON37510H	Electronic versions are uncontrolled except when accessed directly from the Document Repository. Printed versions are uncontrolled except when stamped "CONTROLLED COPY" in red.
DESCRIPTION:	PBGA78 13x10.5	PAGE 1 OF 1

onsemi and onsemi are trademarks of Semiconductor Components Industries, LLC dba onsemi or its subsidiaries in the United States and/or other countries. onsemi reserves the right to make changes without further notice to any products herein. onsemi makes no warranty, representation or guarantee regarding the suitability of its products for any particular purpose, nor does onsemi assume any liability arising out of the application or use of any product or circuit, and specifically disclaims any and all liability, including without limitation special, consequential or incidental damages. onsemi does not convey any license under its patent rights nor the rights of others.

onsemi, **Onsemi**, and other names, marks, and brands are registered and/or common law trademarks of Semiconductor Components Industries, LLC dba "**onsemi**" or its affiliates and/or subsidiaries in the United States and/or other countries. **onsemi** owns the rights to a number of patents, trademarks, copyrights, trade secrets, and other intellectual property. A listing of **onsemi**'s product/patent coverage may be accessed at www.onsemi.com/site/pdf/Patent-Marking.pdf. **onsemi** reserves the right to make changes at any time to any products or information herein, without notice. The information herein is provided "as-is" and **onsemi** makes no warranty, representation or guarantee regarding the accuracy of the information, product features, availability, functionality, or suitability of its products for any particular purpose, nor does **onsemi** assume any liability arising out of the application or use of any product or circuit, and specifically disclaims any and all liability, including without limitation special, consequential or incidental damages. Buyer is responsible for its products and applications using **onsemi** products, including compliance with all laws, regulations and safety requirements or standards, regardless of any support or applications information provided by **onsemi**. "Typical" parameters which may be provided in **onsemi** data sheets and/or specifications can and do vary in different applications and actual performance may vary over time. All operating parameters, including "Typicals" must be validated for each customer application by customer's technical experts. **onsemi** does not convey any license under any of its intellectual property rights nor the rights of others. **onsemi** products are not designed, intended, or authorized for use as a critical component in life support systems or any FDA Class 3 medical devices or medical devices with a same or similar classification in a foreign jurisdiction or any devices intended for implantation in the human body. Should Buyer purchase or use **onsemi** products for any such unintended or unauthorized application, Buyer shall indemnify and hold **onsemi** and its officers, employees, subsidiaries, affiliates, and distributors harmless against all claims, costs, damages, and expenses, and reasonable attorney fees arising out of, directly or indirectly, any claim of personal injury or death associated with such unintended or unauthorized use, even if such claim alleges that **onsemi** was negligent regarding the design or manufacture of the part. **onsemi** is an Equal Opportunity/Affirmative Action Employer. This literature is subject to all applicable copyright laws and is not for resale in any manner.

ADDITIONAL INFORMATION

TECHNICAL PUBLICATIONS:

Technical Library: www.onsemi.com/design/resources/technical-documentation
onsemi Website: www.onsemi.com

ONLINE SUPPORT: www.onsemi.com/support

For additional information, please contact your local Sales Representative at www.onsemi.com/support/sales