

Thank you for your interest in **onsemi** products.
Your technical document begins on the following pages.



Your Feedback is Important to Us!

Please take a moment to participate in our short survey.
At **onsemi**, we are dedicated to delivering technical content that best meets your needs.

[Help Us Improve – Take the Survey](#)

This survey is intended to collect your feedback, capture any issues you may encounter, and to provide improvements you would like to suggest.

We look forward to your feedback.

To learn more about **onsemi**, please visit our website at
www.onsemi.com

onsemi and **onsemi** and other names, marks, and brands are registered and/or common law trademarks of Semiconductor Components Industries, LLC dba "**onsemi**" or its affiliates and/or subsidiaries in the United States and/or other countries. **onsemi** owns the rights to a number of patents, trademarks, copyrights, trade secrets, and other intellectual property. A listing of **onsemi** product/patent coverage may be accessed at www.onsemi.com/site/pdf/Patent-Marking.pdf. **onsemi** reserves the right to make changes at any time to any products or information herein, without notice. The information herein is provided "as-is" and **onsemi** makes no warranty, representation or guarantee regarding the accuracy of the information, product features, availability, functionality, or suitability of its products for any particular purpose, nor does **onsemi** assume any liability arising out of the application or use of any product or circuit, and specifically disclaims any and all liability, including without limitation special, consequential or incidental damages. Buyer is responsible for its products and applications using **onsemi** products, including compliance with all laws, regulations and safety requirements or standards, regardless of any support or applications information provided by **onsemi**. "Typical" parameters which may be provided in **onsemi** data sheets and/or specifications can and do vary in different applications and actual performance may vary over time. All operating parameters, including "Typicals" must be validated for each customer application by customer's technical experts. **onsemi** does not convey any license under any of its intellectual property rights nor the rights of others. **onsemi** products are not designed, intended, or authorized for use as a critical component in life support systems or any FDA Class 3 medical devices or medical devices with a same or similar classification in a foreign jurisdiction or any devices intended for implantation in the human body. Should Buyer purchase or use **onsemi** products for any such unintended or unauthorized application, Buyer shall indemnify and hold **onsemi** and its officers, employees, subsidiaries, affiliates, and distributors harmless against all claims, costs, damages, and expenses, and reasonable attorney fees arising out of, directly or indirectly, any claim of personal injury or death associated with such unintended or unauthorized use, even if such claim alleges that **onsemi** was negligent regarding the design or manufacture of the part. **onsemi** is an Equal Opportunity/Affirmative Action Employer. This literature is subject to all applicable copyright laws and is not for resale in any manner. Other names and brands may be claimed as the property of others.

1/2.9-inch 8 MP CMOS Digital Image Sensor

AR0830

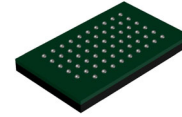

ODCSP59
CASE 570AY

General Description

The **onsemi** AR0830 is a stacked 1/2.9-inch back side illuminated (BSI) CMOS active-pixel digital image sensor with a pixel array of 3840Hx2160V (3856H x 2176V including border pixels). The AR0830 has enhanced NIR response.

It incorporates sophisticated on-chip camera functions such as Wake on Motion (WOM), context switching and multiple subsampling modes. It is programmable through a simple I²C interface and has very low power consumption.

The AR0830 digital image sensor features **onsemi**'s breakthrough low-noise CMOS imaging technology.

The AR0830 sensor can generate full resolution image at up to 60 frames per second (fps) in 10-bit linear mode. AR0830 can achieve 30 fps in line interleaved high dynamic range (LI-HDR) and enhanced Dynamic Range (eDR) modes.

Features

- 8 MP CMOS Sensor with Advanced 1.4 μm Pixel Stacked BSI Technology
- Enhanced NIR Response at 850 nm and 940 nm Wavelength
- LI-HDR: Supports Line Interleaved T1/T2 Readout to Enable HDR Processing in ISP Chip
- enhanced Dynamic Range (eDR)
- Super Low Power Mode (SLP)
- Wake On Motion (WOM)/Motion Detection
- Subsampling Modes: Skipping, Binning, Summing
- Data Interfaces:
 - ◆ MIPI D-PHY – 4 Lanes
- Bit-depth Compression Available for MIPI Interface
- I²C Fast Mode+ Serial Interface (I²C)
- Various Trigger Modes for Multi-sensor Synchronization
- Electronic Rolling Shutter (ERS) and Global Reset Release (GRR) Modes Supported
- Context Switching
- 800 bytes One-time Programmable Memory (OTPM) for Storing Shading Correction Coefficients and Module Information
- Programmable Controls: Gain, Horizontal and Vertical Blanking, Frame Size/Rate, Exposure, Window Size, Cropping and Mirror and Flip
- On-chip Temperature Sensor
- Simple Two-wire Fast-mode+ Serial Interface
- On-chip Lens Shading Correction

ORDERING INFORMATION

See detailed ordering and shipping information on page 3 of this data sheet.

Non-NDA Data Sheet

Interested in what you see? If you would like more detailed information, please request the full version of our data sheet.

[Request Full Data Sheet](#)

Applications

- Videoconferencing Endpoints
- Webcams
- Machine Vision Cameras
- Video Doorbells
- Security Cameras
- Retail In-store Cameras, Bodycams, etc.
- 3D and Stereo Cameras

AR0830

Table 1. KEY PERFORMANCE PARAMETERS

Parameter		Value
Optical Format		1/2.9-inch 8 MP (16:9)
Active Pixels		3840 x 2160
Pixel Size		1.4 μm Back Side Illuminated (BSI),
Chief Ray Angle (CRA)		11°, 35°
Color Filter Array		RGB Bayer, RGB-IR, Monochrome
Input Clock Frequency		6–48 MHz
Interface		4-lane MIPI (1- and 2-lane supported) using D-PHY; Max data rate: 1.5 Gbps/lane
ADC Resolution		10-bits, on die
Gain Control: Gain Table		Linear Mode: 0–53.6 dB total (Analog 0–27.3 dB, Digital 0–26.3 dB)
Subsampling		Subsampling: Skipping (RGB, Mono), Binning (RGB), Summing (Mono) (Note 2)
Temperature Sensor		10-bit, controlled by two-wire serial I/F
Frame Rate	Full Size, Linear Mode	60 fps (MIPIx4), 30 fps (MIPIx2)
Compression		DPCM: 10–8
3D Support		Frame rate and exposure synchronization
Supply Voltage	Analog, Pixel	2.8 V (2.7 V < V_{supply} < 2.9 V)
	I/O	1.8 V (1.7 V < V_{supply} < 1.9 V)
	PLL, MIPIphy	1.05 V (1 V < V_{supply} < 1.1 V)
Power Consumption		190 mW (Typical condition) at 8M and 60 fps
Responsivity		17.3 ke-/lux-sec (Clear in Mono) 8.0 ke-/lux-sec (Green in RGB-IR) 8.7 ke-/lux-sec (Green in RGB)
SNR _{MAX}		39.9 dB
Dynamic Range		100 dB (LI-HDR Mode) 73 dB (eDR 1-exp)
Operating Temperature Range (at junction) – T _J		–30°C to +85°C
Optimal Performance Temperature Range (at junction) – T _J		0°C to +60°C
Package Options:		CSP-59 (6.42 mm x 3.92 mm)
θ_{JA}		30°C/W (Note 1)
θ_{JB}		6°C/W

1. θ_{JA} is dependent on the customer module design and should not be used for calculating junction temperature.
2. Subsampling modes are not available for AR0830 RGBIR sensors.

AR0830

Table 2. 10-bit MODES OF OPERATION

Mode Name	Mode Description	Resolution	Frame Rate
Native	4K Linear Full Res	3840 x 2160	60
Native	4K Linear Full Res, Lower Frame Rate	3840 x 2160	30
SLP Native	4K Linear Full Res, Lowest Power	3840 x 2160	1
LI Native	4K 2-exp LI-HDR	3840 x 2160	30
eDR Native	4K eDR	3840 x 2160	30
Max Frame Rate	Crop Linear for Max Fps	1650 x 1650	90
Bin2	2 MP Linear	1920 x 1080	120
Bin4	0.5 MP Linear	960 x 540	1
WOM Bin4	Wake On Motion w/ Streaming	960 x 540	1

Table 3. 12-bit MODES OF OPERATION

Mode Name	Mode Description	Resolution	Frame Rate
eDR Native	4K eDR	3840 x 2160	30

Table 4. ORDERING INFORMATION

Part Number	Product Description	Orderable Product Attribute Description
AR0830CSSC11SMKA1-CP	8 MP 1/2.9" CMOS Image sensor RGB 11° CRA	CSP with Protective Film
AR0830CSSC11SMKA1-CP2	8 MP 1/2.9" CMOS Image sensor RGB 11° CRA	CSP with Protective Film Low MOQ
AR0830CSSC11SMKAH3-GEVB	8 MP 1/2.9" CMOS Image sensor RGB 11° CRA	Demo3 Headboard

AR0830CSSM11SMKA1-CP	8 MP 1/2.9" CMOS Image sensor Mono 11° CRA	CSP with Protective Film
AR0830CSSM11SMKA1-CP2	8 MP 1/2.9" CMOS Image sensor Mono 11° CRA	CSP with Protective Film Low MOQ
AR0830CSSM11SMKAH3-GEVB	8 MP 1/2.9" CMOS Image sensor Mono 11° CRA	Demo3 Headboard

AR0830CSSH11SMKA1-CP	8 MP 1/2.9" CMOS Image sensor RGBIR 11° CRA	CSP with Protective Film
AR0830CSSH11SMKA1-CP2	8 MP 1/2.9" CMOS Image sensor RGBIR 11° CRA	CSP with Protective Film Low MOQ
AR0830CSSH11SMKAH3-GEVB	8 MP 1/2.9" CMOS Image sensor RGBIR 11° CRA	Demo3 Headboard

AR0830CSSC35SMKA1-CP	8 MP 1/2.9" CMOS Image sensor RGB 35° CRA	CSP with Protective Film
AR0830CSSC35SMKA1-CP2	8 MP 1/2.9" CMOS Image sensor RGB 35° CRA	CSP with Protective Film Low MOQ
AR0830CSSC35SMKAH3-GEVB	8 MP 1/2.9" CMOS Image sensor RGB 35° CRA	Demo3 Headboard

AR0830CSSH35SMKA1-CP	8 MP 1/2.9" CMOS Image sensor RGBIR 35° CRA	CSP with Protective Film
AR0830CSSH35SMKA1-CP2	8 MP 1/2.9" CMOS Image sensor RGBIR 35° CRA	CSP with Protective Film Low MOQ
AR0830CSSH35SMKAH3-GEVB	8 MP 1/2.9" CMOS Image sensor RGBIR 35° CRA	Demo Headboard

3. Refer to AR0830 Die Data Sheet for Die Part Numbers & Ordering Information.

AR0830

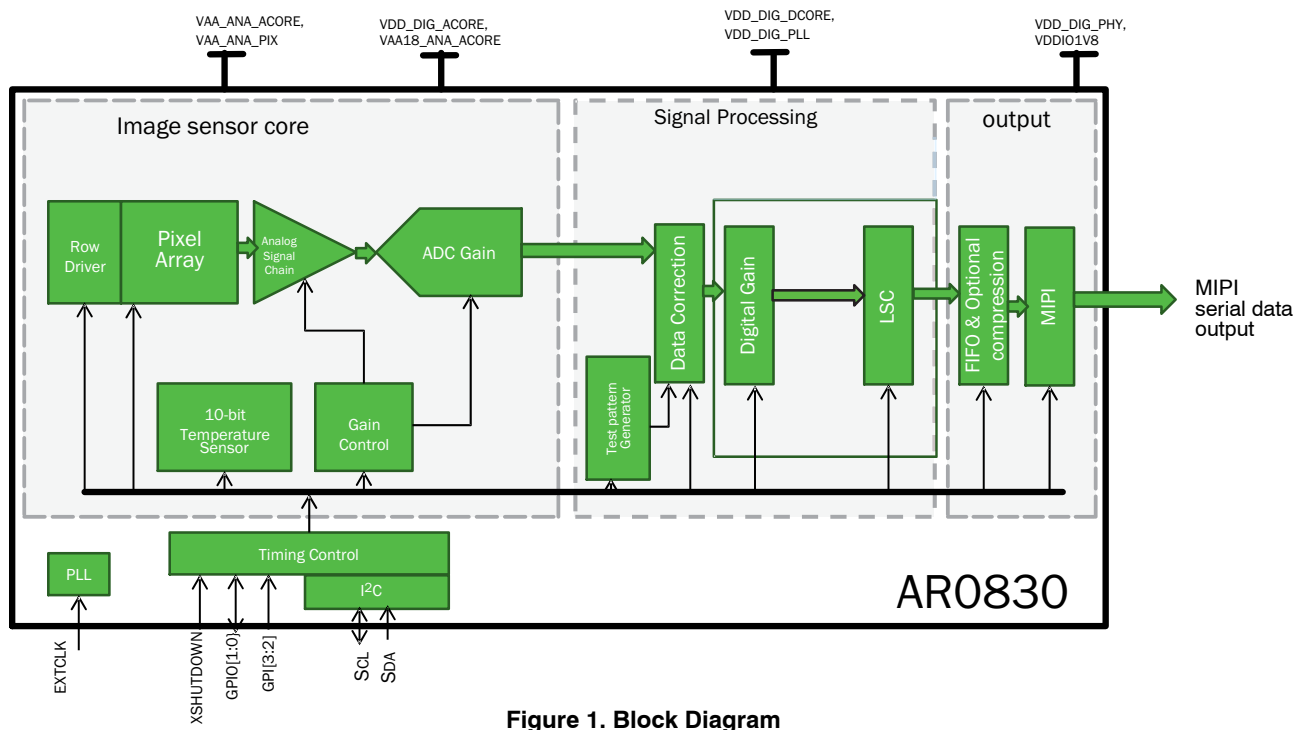
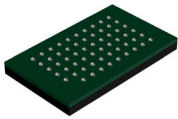
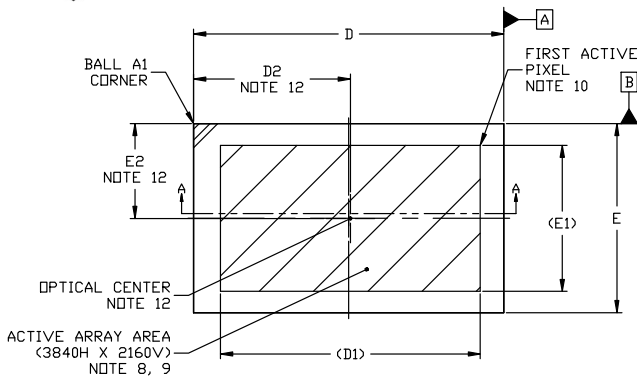

Figure 1. Block Diagram



ODCSP59 6.41x3.91x0.63, 0.50P
CASE 570AY
ISSUE O

DATE 15 NOV 2023



TOP VIEW

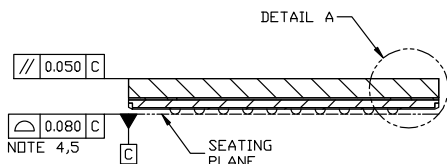

SECTION A-A

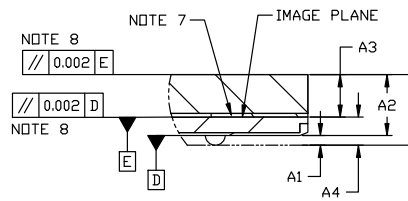

DETAIL "A"
SCALE 2:1

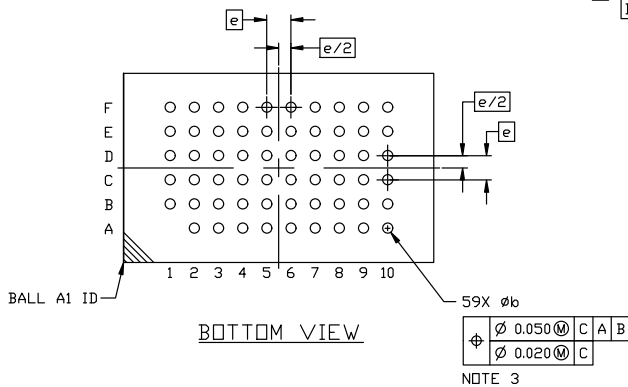

BOTTOM VIEW

DIM	MILLIMETERS		
	MIN.	NOM.	MAX.
A	----	----	0.762
A1	0.081	0.101	0.121
A2	0.631 REF.		
A3	0.425	0.440	0.455
A4	0.252	0.292	0.332
b	0.184	0.204	0.224
D	6.392	6.417	6.442
D1	5.376 REF.		
D2	3.218	3.243	3.268
E	3.889	3.914	3.939
E1	3.024 REF.		
E2	1.937	1.962	1.987
e	0.500 BSC		

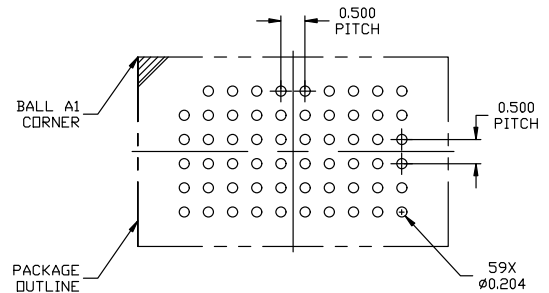

RECOMMENDED MOUNTING FOOTPRINT*

*FOR ADDITIONAL INFORMATION ON OUR Pb-FREE STRATEGY AND SOLDERING DETAILS, PLEASE DOWNLOAD THE ON SEMICONDUCTOR SOLDERING AND MOUNTING TECHNIQUES REFERENCE MANUAL, SOLDERRM/D.

NOTES:

1. DIMENSIONING AND TOLERANCING CONFORM TO ASME Y14.5-2018.
2. ALL DIMENSION ARE IN MILLIMETERS.
3. SOLDER BALL DIAMETER IS MEASURED AT THE MAXIMUM SOLDER BALL DIAMETER PARALLEL TO DATUM C.
4. COPLANARITY APPLIES TO THE SPHERICAL CROWNS OF THE SOLDER BALLS.
5. DATUM C, THE SEATING PLANE IS DEFINED BY THE SPHERICAL CROWNS OF THE SOLDER BALLS.
6. GLASS: 0.400 THICKNESS; REFRACTIVE INDEX = 1.52.
7. AIR GAP BETWEEN GLASS AND PIXEL ARRAY: 0.040 THICKNESS.
8. PARALLELISM APPLIES ONLY TO THE ACTIVE ARRAY.
9. MAXIMUM ROTATION OF ACTIVE ARRAY RELATIVE TO DATUMS A AND B IS $\pm 0.1^\circ$.
10. REFER TO THE DEVICE DATA SHEET FOR TOTAL PIXEL ARRAY DEFINITIONS.
11. PACKAGE CENTER (X, Y) = (0.000, 0.000).
12. OPTICAL CENTER RELATIVE TO PACKAGE CENTER (X, Y) = (0.035, -0.005).

GENERIC MARKING DIAGRAM*

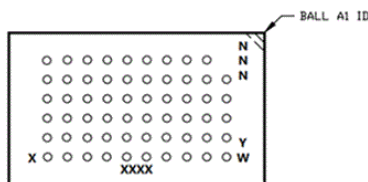

XXXX = Specific Device Code
Y = Year
W = Work Week
NNN = Serial Number

*This information is generic. Please refer to device data sheet for actual part marking. Pb-Free indicator, "G" or microdot "•", may or may not be present. Some products may not follow the Generic Marking.

DOCUMENT NUMBER:	98AON93899G	Electronic versions are uncontrolled except when accessed directly from the Document Repository. Printed versions are uncontrolled except when stamped "CONTROLLED COPY" in red.
DESCRIPTION:	ODCSP59 6.41x3.91x0.63, 0.50P	PAGE 1 OF 1

onsemi and ONSEMI are trademarks of Semiconductor Components Industries, LLC dba onsemi or its subsidiaries in the United States and/or other countries. onsemi reserves the right to make changes without further notice to any products herein. onsemi makes no warranty, representation or guarantee regarding the suitability of its products for any particular purpose, nor does onsemi assume any liability arising out of the application or use of any product or circuit, and specifically disclaims any and all liability, including without limitation special, consequential or incidental damages. onsemi does not convey any license under its patent rights nor the rights of others.

onsemi, **Onsemi**, and other names, marks, and brands are registered and/or common law trademarks of Semiconductor Components Industries, LLC dba "**onsemi**" or its affiliates and/or subsidiaries in the United States and/or other countries. **onsemi** owns the rights to a number of patents, trademarks, copyrights, trade secrets, and other intellectual property. A listing of **onsemi**'s product/patent coverage may be accessed at www.onsemi.com/site/pdf/Patent-Marking.pdf. **onsemi** reserves the right to make changes at any time to any products or information herein, without notice. The information herein is provided "as-is" and **onsemi** makes no warranty, representation or guarantee regarding the accuracy of the information, product features, availability, functionality, or suitability of its products for any particular purpose, nor does **onsemi** assume any liability arising out of the application or use of any product or circuit, and specifically disclaims any and all liability, including without limitation special, consequential or incidental damages. Buyer is responsible for its products and applications using **onsemi** products, including compliance with all laws, regulations and safety requirements or standards, regardless of any support or applications information provided by **onsemi**. "Typical" parameters which may be provided in **onsemi** data sheets and/or specifications can and do vary in different applications and actual performance may vary over time. All operating parameters, including "Typicals" must be validated for each customer application by customer's technical experts. **onsemi** does not convey any license under any of its intellectual property rights nor the rights of others. **onsemi** products are not designed, intended, or authorized for use as a critical component in life support systems or any FDA Class 3 medical devices or medical devices with a same or similar classification in a foreign jurisdiction or any devices intended for implantation in the human body. Should Buyer purchase or use **onsemi** products for any such unintended or unauthorized application, Buyer shall indemnify and hold **onsemi** and its officers, employees, subsidiaries, affiliates, and distributors harmless against all claims, costs, damages, and expenses, and reasonable attorney fees arising out of, directly or indirectly, any claim of personal injury or death associated with such unintended or unauthorized use, even if such claim alleges that **onsemi** was negligent regarding the design or manufacture of the part. **onsemi** is an Equal Opportunity/Affirmative Action Employer. This literature is subject to all applicable copyright laws and is not for resale in any manner.

ADDITIONAL INFORMATION

TECHNICAL PUBLICATIONS:

Technical Library: www.onsemi.com/design/resources/technical-documentation
onsemi Website: www.onsemi.com

ONLINE SUPPORT: www.onsemi.com/support

For additional information, please contact your local Sales Representative at www.onsemi.com/support/sales