

## GU 1 Form A Short Circuit Protection non-latch type

### Short circuit protection (Non-latch type) only for DC load

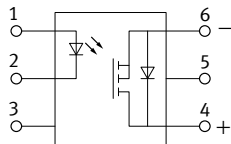
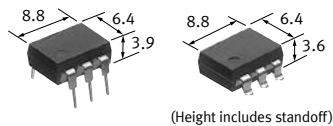

(Unit: mm)

#### FEATURES

- Protects Circuit from excess current
- No need for fuses, poly switches, or other protectors
- High capacity  
Can control up to 0.5A (60V DC) load current.

#### TYPICAL APPLICATIONS

- Industrial equipment
- Security equipment

Note: Please contact our sales representative for automotive applications of PhotoMOS.

#### TYPES

Category	Output rating*1		Part No.				Packing quantity	
	Load voltage	Load current	Through hole terminal	Surface mount terminal			Tube	Tape and reel
			Tube packing style	Tape and reel packing style X*2	Tape and reel packing style Z*2			
DC only	60 V	500 mA	AQV112KL	AQV112KLA	AQV112KLAX	AQV112KLAZ	1-tube: 50 pcs. Outer carton: 500 pcs.	1-reel: 1,000 pcs. Outer carton: 1,000 pcs.

Note: The surface mount terminal shape indicator "A" and the packing style indicator "X" or "Z" are not marked on the device. (Ex. the label for product number AQV112KLAX is AQV112KL.)

\*1. Indicate the DC values.

\*2. Tape and reel packing style X: picked from the 1/2/3-pin side, tape and reel packing style Z: picked from the 4/5/6-pin side.

#### RATING

##### Absolute maximum ratings (Ambient temperature: 25°C)

Item		Symbol	AQV112KL (A)	Remarks
Input	LED forward current	$I_F$	50 mA	
	LED reverse voltage	$V_R$	5 V	
	Peak forward current	$I_{FP}$	1 A	f = 100 Hz, Duty Ratio = 0.1%
	Power dissipation	$P_{in}$	75 mW	
Output	Load voltage (peak AC)	$V_L$	7 to 60V	
	Continuous load current	$I_L$	0.5 A	Peak AC, DC
	Power dissipation	$P_{out}$	500 mW	
Total power dissipation		$P_T$	550 mW	
I/O isolation voltage		$V_{iso}$	1,500 Vrms	
Ambient temperature (Operating)		$T_{opr}$	-40 to +85°C	(Avoid icing and condensation)
Ambient temperature (Storage)		$T_{stg}$	-40 to +100°C	

# PhotoMOS GU 1 Form A Short Circuit Protection

## ■ Electrical characteristics (Ambient temperature: 25°C)

Item		Symbol	AQV112KL (A)	Condition	
Input	LED operate current	Typical	0.8 mA	$I_L = 100 \text{ mA}$	
		Maximum	10 mA		
	LED turn off current	Minimum	0.3 mA	$I_L = 100 \text{ mA}$	
		Typical	0.7 mA		
LED dropout voltage	Typical	1.35 V (1.17 V at $I_F = 10 \text{ mA}$ )		$I_F = 50 \text{ mA}$	
	Maximum	1.5 V			
Output	On resistance	Typical	0.55 $\Omega$	$I_F = 10 \text{ mA}$ $I_L = \text{Max.}$ Within 1 s	
		Maximum	2.0 $\Omega$		
	Load short circuit detection voltage*1	Typical	5 V	$I_F = 10 \text{ mA}$	
		Maximum	7 V		
Off state leakage current	Maximum	$I_{Leak}$	1 $\mu\text{A}$	$I_F = 0 \text{ mA}$ $V_L = \text{Max.}$	
Transfer characteristics	Turn on time*2	Typical	$T_{on}$	2.0 ms	$I_F = 10 \text{ mA}$ $I_L = 100 \text{ mA}$ $V_L = 10 \text{ V}$
		Maximum		5.0 ms	
	Turn off time*2	Typical	$T_{off}$	0.1 ms	$I_F = 10 \text{ mA}$ $I_L = 100 \text{ mA}$ $V_L = 10 \text{ V}$
		Maximum		1.0 ms	
	I/O capacitance	Typical	$C_{iso}$	0.8 pF	$f = 1 \text{ MHz}$ $V_B = 0 \text{ V}$
		Maximum		1.5 pF	
Initial I/O isolation resistance	Minimum	$R_{iso}$	1,000 M $\Omega$	500 V DC	

\*1. At  $I_F = 10 \text{ mA}$ , load current will be oscillated if the voltage between 4 (+) -6 (-) terminals becomes more than the detection voltage of the short circuit.

\*2. Turn on/Turn off time

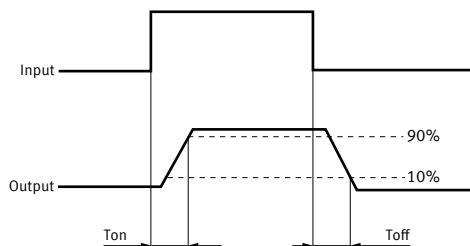

## ■ Recommended operating conditions (Ambient temperature: 25°C)

Please use under recommended operating conditions to obtain expected characteristics.

Item	Symbol	Min.	Max.	Unit
LED current	$I_F$	10	30	mA
AQV112KL (A) Load voltage (DC)	$V_L$	10	48	V
Continuous load current (DC)	$I_L$	-	0.5	A

REFERENCE DATA

1. Load current vs. ambient temperature characteristics

Allowable ambient temperature: -40 to +85°C

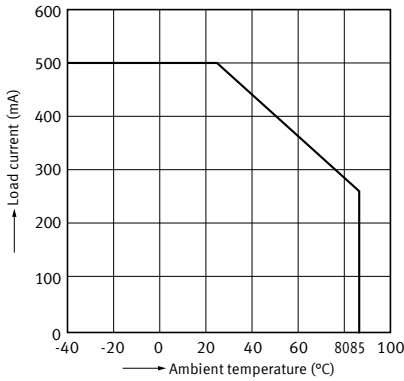

2. On resistance vs. ambient temperature characteristics

Measured portion: between terminals 4 and 6;  
LED current: 10 mA; Load current: Max. (DC)

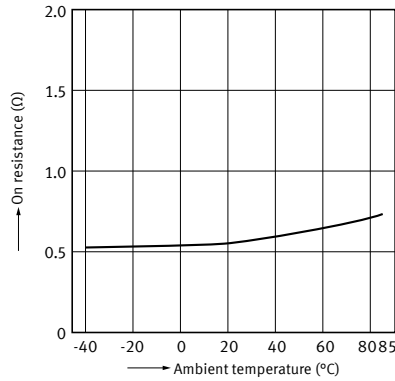

3. Turn on time vs. ambient temperature characteristics

Measured portion: between terminals 4 and 6;  
LED current: 10 mA; Load voltage: 10 V (DC);  
Load current: 100 mA

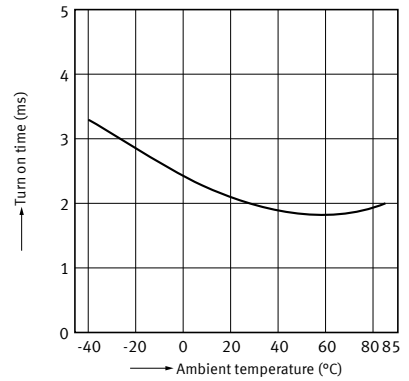

4. Turn off time vs. ambient temperature characteristics

Measured portion: between terminals 4 and 6;  
LED current: 10 mA; Load voltage: 10 V (DC);  
Load current: 100 mA (DC)

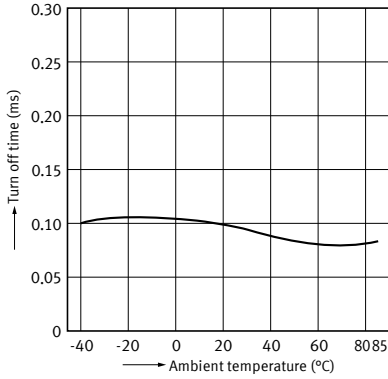

5. LED operate current vs. ambient temperature characteristics

Measured portion: between terminals 4 and 6;  
Load current: 100 mA

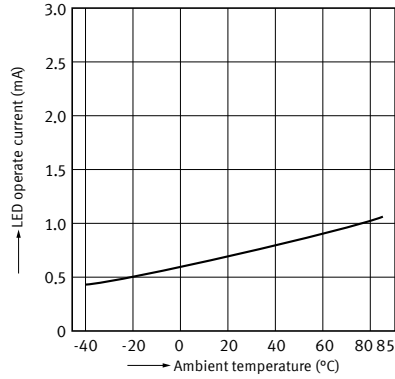

6. LED turn off current vs. ambient temperature characteristics

Measured portion: between terminals 4 and 6;  
Load current: 100 mA

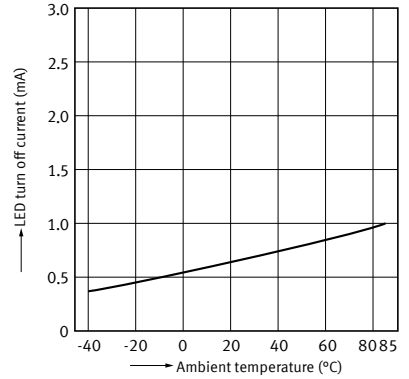

7. Off state leakage current vs. load voltage characteristics

Measured portion: between terminals 4 and 6;  
Ambient temperature: 25°C

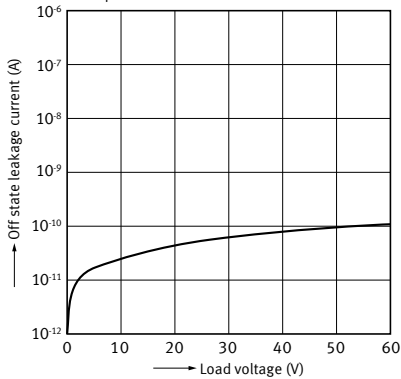

8. Current vs. voltage characteristics of output at MOS portion

Measured portion: between terminals 4 and 6;  
Ambient temperature: 25°C

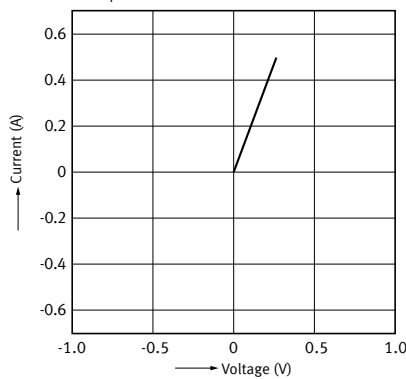

9. LED dropout voltage vs. ambient temperature characteristics

Measured portion: between terminals 1 and 2;  
LED current: 10 to 50 mA

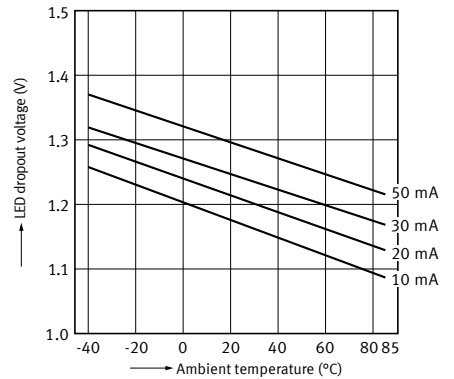

# PhotoMOS GU 1 Form A Short Circuit Protection

## 10. Turn on time vs. LED forward current characteristics

Measured portion: between terminals 4 and 6;  
Load voltage: 10 V (DC); Load current: 100 mA (DC);  
Ambient temperature: 25°C

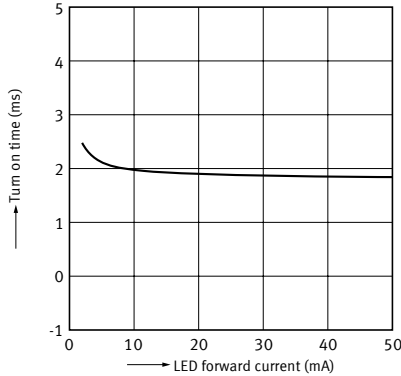

## 11. Turn off time vs. LED forward current characteristics

Measured portion: between terminals 4 and 6;  
Load voltage: 10 V (DC); Load current: 100 mA (DC);  
Ambient temperature: 25°C

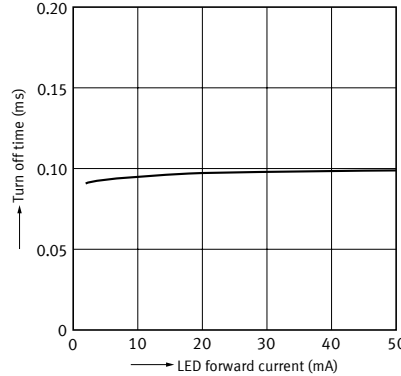

## 12. Output capacitance vs. applied voltage characteristics

Measured portion: between terminals 4 and 6;  
Frequency: 1 MHz; Ambient temperature: 25°C

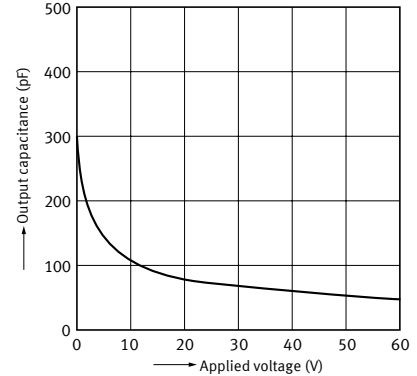

## 13. Short circuit peak current vs. time characteristics

Measured portion: between terminals 4 and 6;  
LED current: 10 mA; Load resistance: 0 Ω;  
Ambient temperature: 25°C

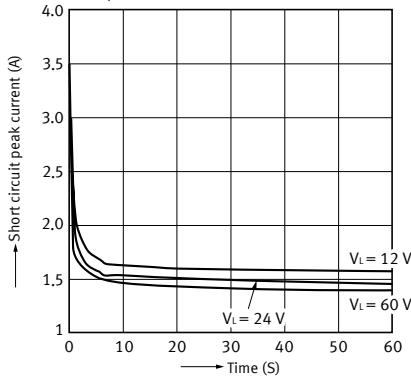

## 14. Short current monitoring interval vs. time characteristics

Measured portion: between terminals 4 and 6;  
LED current: 10 mA; Load resistance: 0 Ω;  
Ambient temperature: 25°C

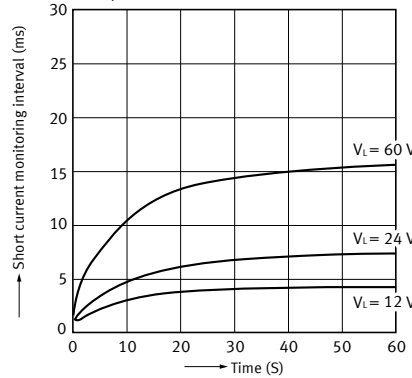

### What is short circuit protection Non-latch type?

If the load current reaches a predetermined overcurrent level, the output-side short circuit protection function cuts off the load current. It then monitors the load current, and if it returns to normal, automatically recovers to normal device operation.

In order to operate the short circuit protection function, ensure that the input current is at least  $I_F = 10$  mA.

### ● Operation chart (Non-latch type)

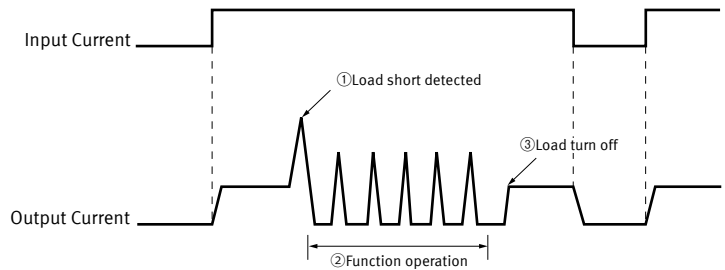

**DIMENSIONS**

**CAD** The CAD data of the products with a "CAD" mark can be downloaded from our Website.

Unit: mm

**CAD**

Through hole terminal type  
External dimensions

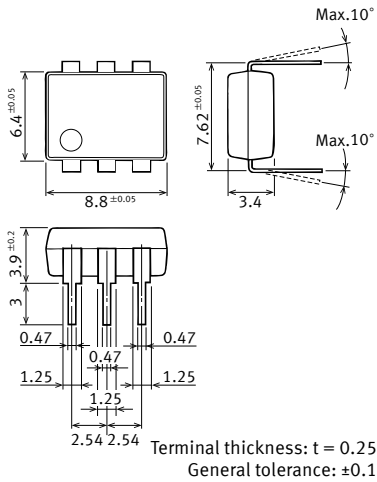

**CAD**

Surface mount terminal type  
External dimensions

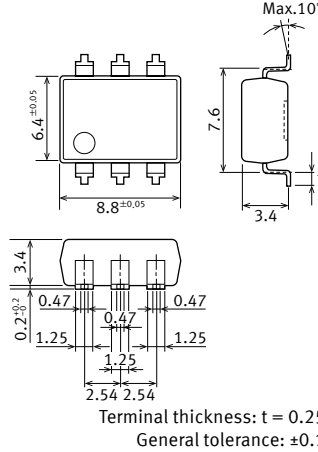

PC board pattern  
(Bottom view)

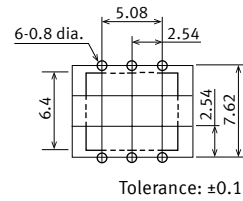

Recommended mounting pad  
(Top view)

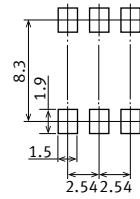

Tolerance: ±0.1

**SCHEMATIC AND WIRING DIAGRAMS**

Schematic	Output configuration	Load type	Connection	Wiring diagram
<p>*</p>	1 Form A	DC	A	

\*Terminal 3 cannot be used, since it is in the internal circuit of the device.

**SAFETY STANDARDS**

Part No.	UL (Recognized)		CSA (Certified)		Remarks
	File No. (Standard No.)	Contact rating	File No. (Standard No.)	Contact rating	
AC/DC dual use AQV112KL (A)	E191218 (UL1577)	0.5A 60V DC	(Certified by C-UL)		VDE approved (Nr. 40051981)

Note: For the latest information on compliance with safety standards, please refer to our website.

Please refer to **"the latest product specifications"** when designing your product.  
 •Requests to customers:  
<https://industrial.panasonic.com/ac/e/salespolicies/>

---

Please contact .....

**Panasonic Corporation**

Electromechanical Control Business Division

■1006, Oaza Kadoma, Kadoma-shi, Osaka 571-8506, Japan  
[industrial.panasonic.com/ac/e/](http://industrial.panasonic.com/ac/e/)

**Panasonic**<sup>®</sup>

©Panasonic Corporation 2020