

Description

The DIODES™ AP61300/AP61302 is a 3A, synchronous buck converter with a wide input voltage range of 2.4V to 5.5V. The device fully integrates a 70mΩ high-side power MOSFET and a 50mΩ low-side power MOSFET to provide high-efficiency step-down DC-DC conversion.

The AP61300/AP61302 device is easily used by minimizing the external component count due to its adoption of Constant On-Time (COT) control to achieve fast transient response, easy loop stabilization, and low output voltage ripple.

The device is available in a SOT563 package.

Features

- VIN: 2.4V to 5.5V
- Output Voltage (VOUT): 0.6V to VIN
- 3A Continuous Output Current
- 0.6V ± 2% Reference Voltage
- 19µA Low Quiescent Current (Pulse Frequency Modulation)
- 2.2MHz Switching Frequency (VIN = 5V, VOUT = 1.8V)
- Up to 84% Efficiency at 5mA Light Load
- Programmable Operation Mode Through EN
 - Pulse Frequency Modulation
 - Pulse Width Modulation Regardless of Output Load
- Low-Dropout (LDO) Mode
- Power-Good Indicator
 - AP61302
- Protection Circuitry
 - Undervoltage Lockout (UVLO)
 - VIN Overvoltage Protection (OVP)
 - Peak Current Limit
 - Valley Current Limit
 - Thermal Shutdown
- **Totally Lead-Free & Fully RoHS Compliant (Notes 1 & 2)**
- **Halogen and Antimony Free. “Green” Device (Note 3)**
- **An Automotive-Compliant Part is Available Under Separate Datasheet ([AP61300Q/AP61302Q](#))**

Notes: 1. No purposely added lead. Fully EU Directive 2002/95/EC (RoHS), 2011/65/EU (RoHS 2) & 2015/863/EU (RoHS 3) compliant.
 2. See <https://www.diodes.com/quality/lead-free/> for more information about Diodes Incorporated’s definitions of Halogen- and Antimony-free, “Green” and Lead-free.
 3. Halogen- and Antimony-free “Green” products are defined as those which contain <900ppm bromine, <900ppm chlorine (<1500ppm total Br + Cl) and <1000ppm antimony compounds.

Pin Assignments

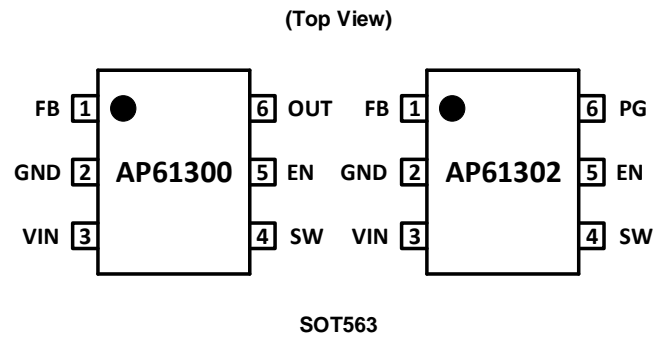

Applications

- 5V distributed power bus supplies
- White goods and small home appliances
- FPGA, DSP, and ASIC supplies
- Network video cameras
- Wireless routers
- Consumer electronics
- General purpose point of loads

Typical Application Circuit

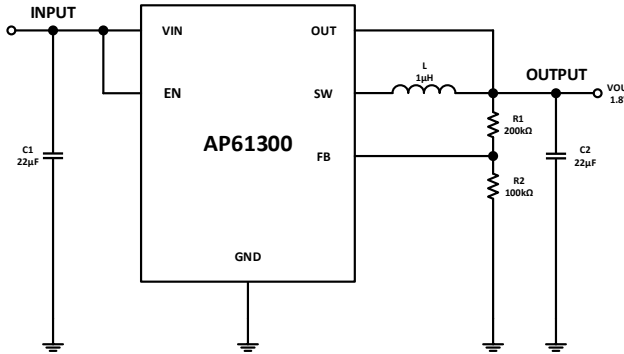

Figure 1. Typical AP61300 Application Circuit

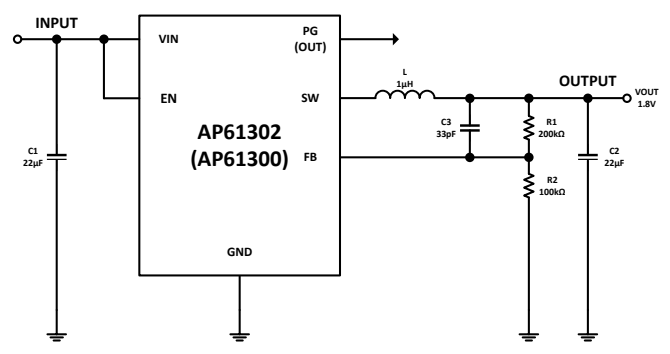

Figure 2. Typical AP61302 (AP61300 OUT as NC) Application Circuit

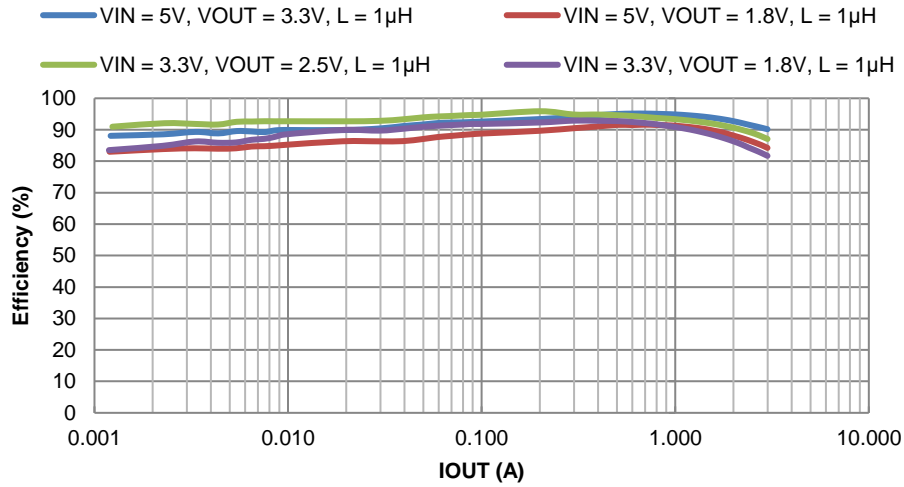

Figure 3. PFM Efficiency vs. Output Current

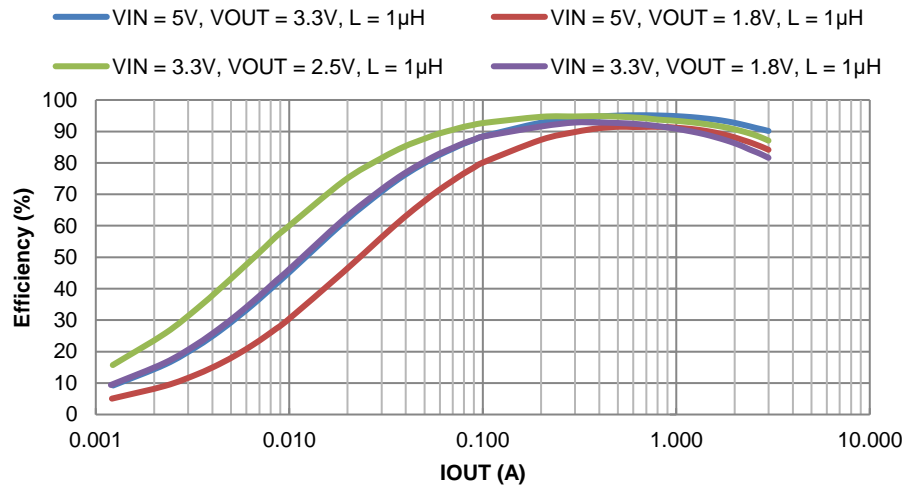

Figure 4. PWM Efficiency vs. Output Current

Pin Descriptions

Pin Name	Pin Number	Function
FB	1	Feedback sensing terminal for the output voltage. Connect this pin to the resistive divider of the output. See Setting the Output Voltage section for more details.
GND	2	Power Ground.
VIN	3	Power Input. VIN supplies the power to the IC as well as the step-down converter power MOSFETs. Drive VIN with a 2.4V to 5.5V power source. Bypass VIN to GND with a suitably large capacitor to eliminate noise due to the switching of the IC. See Input Capacitor section for more details.
SW	4	Power Switching Output. SW is the switching node that supplies power to the output. Connect the output LC filter from SW to the output load.
EN	5	Enable Input. EN is a digital input that turns the regulator on or off. Drive EN high to turn on the regulator and low to turn it off. EN is used to program the Operation Mode (PFM or PWM). See Enable section for more details.
OUT (AP61300)	6	Output Voltage Power Rail. Connect OUT to the output load in Figure 1 and do not tie OUT to GND. OUT pin is also allow for no connect, then C3 must be install as in Figure 2.
PG (AP61302)		Power-Good. Open drain power-good output that is pulled to GND when the output voltage is out of its regulation limits or during soft-start.

Functional Block Diagram

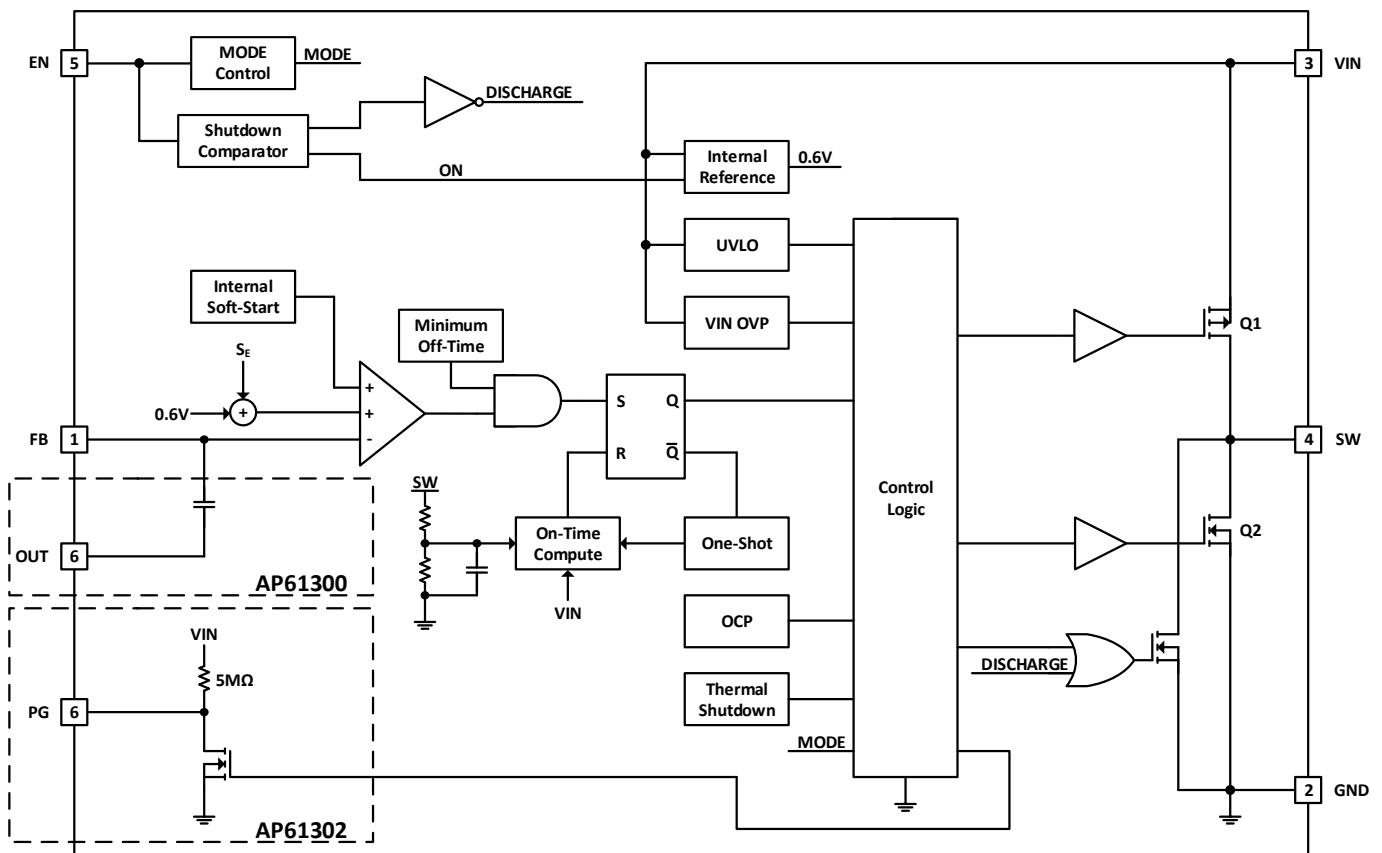

Figure 5. Functional Block Diagram

Absolute Maximum Ratings (Note 4) (@ T_A = +25°C, unless otherwise specified.)

Symbol	Parameter	Rating	Unit
V _{IN}	Supply Pin Voltage	-0.3 to +6.5 (DC)	V
		-0.3 to +7.0 (400ms)	
V _{FB}	Feedback Pin Voltage	-0.3 to V _{IN} + 0.3	V
V _{SW}	Switch Pin Voltage	-1.0 to V _{IN} + 0.3 (DC)	V
		-2.5 to V _{IN} + 2.0 (20ns)	
V _{EN}	Enable Pin Voltage	-0.3 to V _{IN} + 0.3	V
V _{OUT} (AP61300)	Output Pin Voltage	-0.3 to +6.0 (DC)	V
V _{PG} (AP61302)	Power-Good Pin Voltage	-0.3 to +6.0 (DC)	V
T _{ST}	Storage Temperature	-65 to +150	°C
T _J	Junction Temperature	+160	°C
T _L	Lead Temperature	+260	°C
ESD Susceptibility (Note 5)			
HBM	Human Body Model	±6000	V
CDM	Charged Device Model	±2000	V

- Notes:
- Stresses greater than the *Absolute Maximum Ratings* specified above can cause permanent damage to the device. These are stress ratings only; functional operation of the device at these or any other conditions exceeding those indicated in this specification is not implied. Device reliability can be affected by exposure to absolute maximum rating conditions for extended periods of time.
 - Semiconductor devices are ESD sensitive and can be damaged by exposure to ESD events. Suitable ESD precautions should be taken when handling and transporting these devices.

Thermal Resistance (Note 6)

Symbol	Parameter	Rating		Unit
θ _{JA}	Junction to Ambient	SOT563	141	°C/W
θ _{JC}	Junction to Case	SOT563	33	°C/W

- Note: 6. Test condition for SOT563: Device mounted on FR-4 substrate, two-layer PCB, 2oz copper, with minimum recommended pad layout.

Recommended Operating Conditions (Note 7) (@ T_A = +25°C, unless otherwise specified.)

Symbol	Parameter	Min	Max	Unit
V _{IN}	Supply Voltage	2.4	5.5	V
V _{OUT}	Output Voltage	0.6	V _{IN}	V
T _A	Operating Ambient Temperature	-40	+85	°C
T _J	Operating Junction Temperature	-40	+125	°C

- Note: 7. The device function is not guaranteed outside of the recommended operating conditions.

Electrical Characteristics (@ $T_J = +25^\circ\text{C}$, $V_{IN} = 5\text{V}$, unless otherwise specified. Min/Max limits apply across the recommended operating junction temperature range, -40°C to $+125^\circ\text{C}$, and input voltage range, 2.4V to 5.5V, unless otherwise specified.)

Symbol	Parameter	Conditions	Min	Typ	Max	Unit
ISHDN	Shutdown Supply Current	$V_{EN} = 0\text{V}$	—	0.1	—	μA
I _Q	Quiescent Supply Current	PFM, $V_{FB} = 0.65\text{V}$	—	19	—	μA
		PWM, $V_{FB} = 0.65\text{V}$	—	690	—	μA
POR	VIN Power-on Reset Rising Threshold	—	—	2.3	2.4	V
UVLO	VIN Undervoltage Lockout Falling Threshold	—	—	2.2	—	V
OVP _{VIN}	VIN Overvoltage Rising Threshold	—	—	6.3	—	V
OVP _{VIN_HYS}	VIN Overvoltage Hysteresis	—	—	300	—	mV
R _{DS(ON)1}	High-Side Power MOSFET On-Resistance (Note 8)	—	—	70	—	m Ω
R _{DS(ON)2}	Low-Side Power MOSFET On-Resistance (Note 8)	—	—	50	—	m Ω
I _{PEAK_LIMIT}	HS Peak Current Limit (Note 8)	From Source to Drain	3.5	5.5	—	A
I _{VALLEY_LIMIT}	LS Valley Current Limit (Note 8)	From Source to Drain	—	3.2	—	A
f _{SW}	Oscillator Frequency	V _{OUT} = 1.8V, CCM	—	2.2	—	MHz
t _{ON_MIN}	Minimum On-Time	—	—	70	—	ns
t _{OFF_MIN}	Minimum Off-Time	—	—	70	—	ns
V _{FB}	Feedback Voltage	CCM	0.588	0.600	0.612	V
V _{EN_H}	EN Logic High Threshold	—	—	0.91	—	V
V _{EN_L}	EN Logic Low Threshold	—	—	0.83	—	V
t _{SS}	Soft-Start Time	—	—	0.5	—	ms
PG _{UV_FALL}	Undervoltage Falling Threshold	AP61302, Percent of Output Regulation, Fault	—	90	—	%
PG _{UV_RISE}	Undervoltage Rising Threshold	AP61302, Percent of Output Regulation, Good	—	95	—	%
PG _{OV_RISE}	Overvoltage Rising Threshold	AP61302, Percent of Output Regulation, Fault	—	110	—	%
PG _{OV_FALL}	Overvoltage Falling Threshold	AP61302, Percent of Output Regulation, Good	—	105	—	%
t _{PG_RD}	Power-Good Rise Delay Time	AP61302	—	40	—	μs
V _{PG_OL}	Power-Good Output Logic Low	AP61302, I _{PG} = -1mA	—	—	0.4	V
R _{PG}	Power-Good Pull-Up Resistor	AP61302	—	5	—	M Ω
T _{SD}	Thermal Shutdown (Note 8)	—	—	+160	—	$^\circ\text{C}$
T _{Hys}	Thermal Shutdown Hysteresis (Note 8)	—	—	+30	—	$^\circ\text{C}$

Note: 8. Compliance to the datasheet limits is assured by one or more methods: production test, characterization, and/or design.

Typical Performance Characteristics (AP61300/AP61302 @ $T_A = +25^\circ\text{C}$, $V_{IN} = 5\text{V}$, $V_{OUT} = 1.8\text{V}$, BOM = Table 1, unless otherwise specified.)

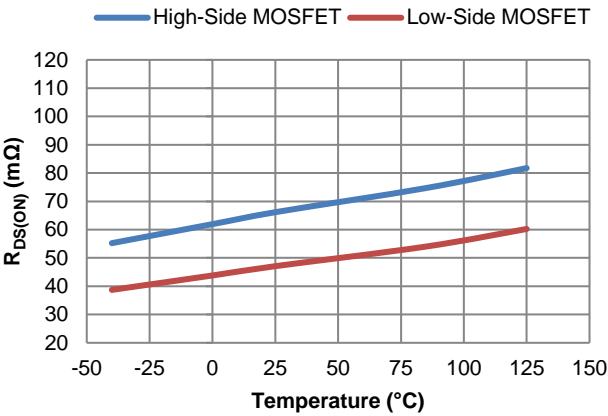

Figure 6. Power MOSFET $R_{DS(ON)}$ vs. Temperature

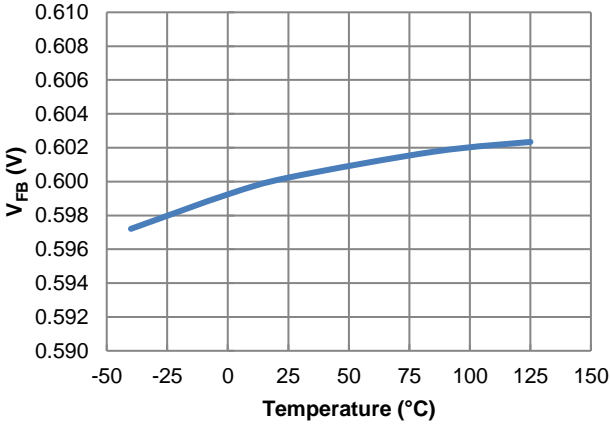

Figure 7. V_{FB} vs. Temperature

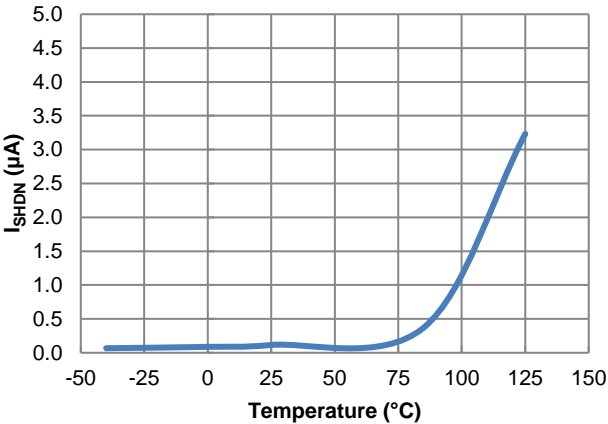

Figure 8. I_{SHDN} vs. Temperature

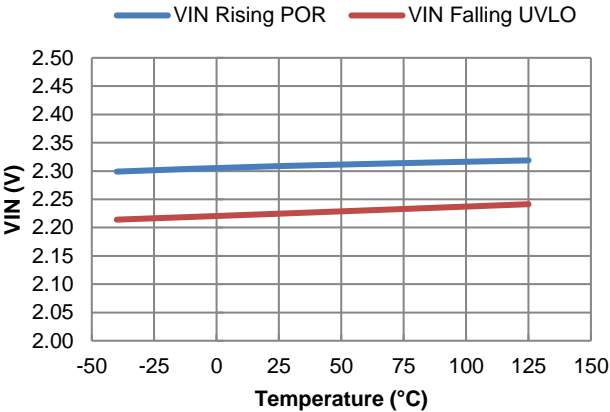

Figure 9. V_{IN} Power-On Reset and UVLO vs. Temperature

Typical Performance Characteristics (AP61300/AP61302 @ $T_A = +25^\circ\text{C}$, $V_{IN} = 5\text{V}$, $V_{OUT} = 1.8\text{V}$, BOM = Table 1, PFM, unless otherwise specified.)

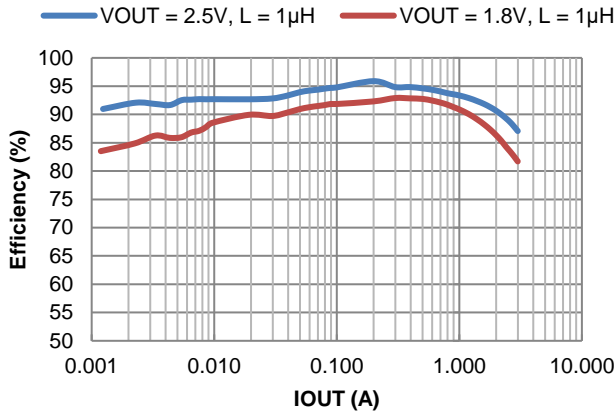

Figure 10. Efficiency vs. Output Current, VIN = 3.3V

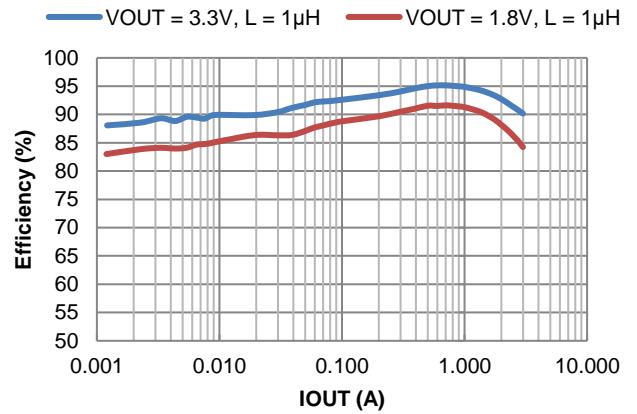

Figure 11. Efficiency vs. Output Current, VIN = 5V

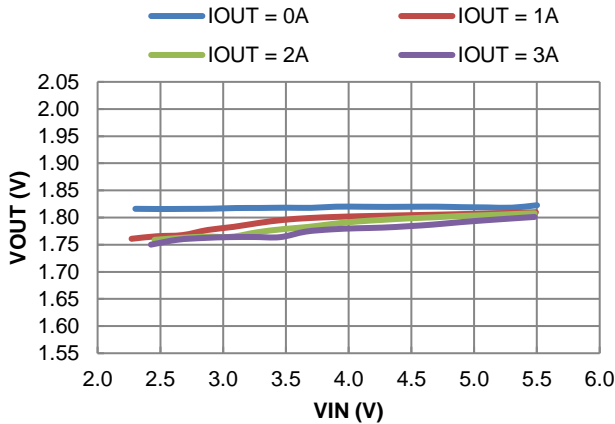

Figure 12. Line Regulation

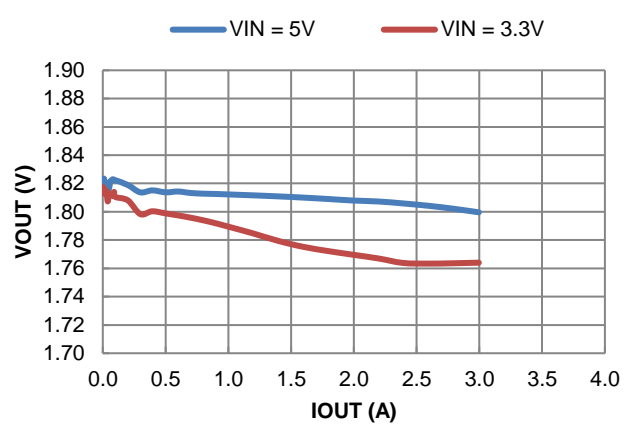

Figure 13. Load Regulation

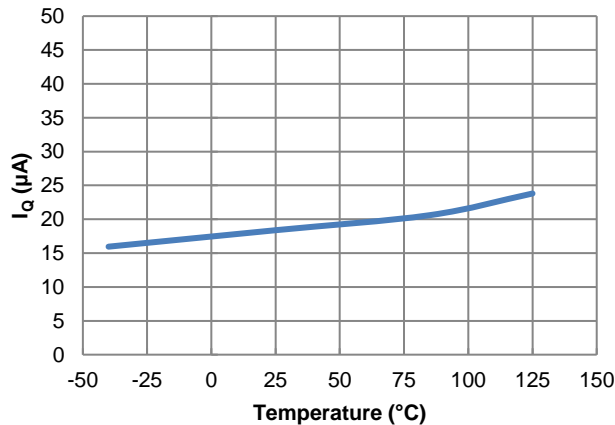

Figure 14. IQ vs. Temperature

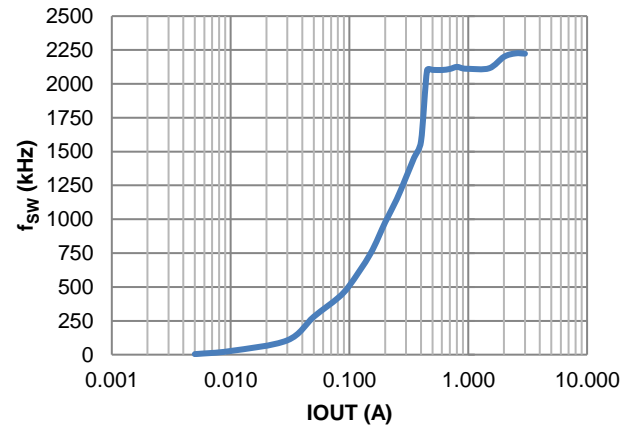

Figure 15. fsw vs. Load

Typical Performance Characteristics (AP61300/AP61302 @ $T_A = +25^\circ\text{C}$, $V_{IN} = 5\text{V}$, $V_{OUT} = 1.8\text{V}$, BOM = Table 1, PFM, unless otherwise specified.) (continued)

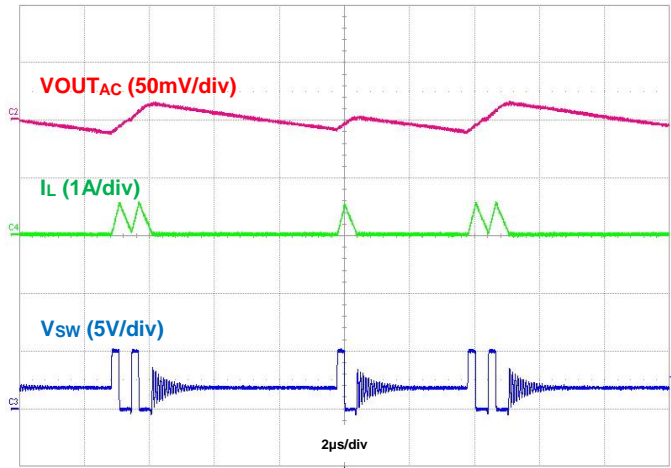

Figure 16. Output Voltage Ripple, $I_{OUT} = 50\text{mA}$

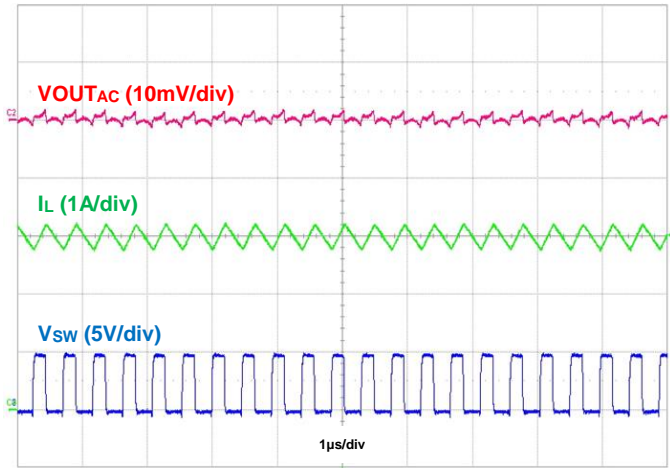

Figure 17. Output Voltage Ripple, $I_{OUT} = 3\text{A}$

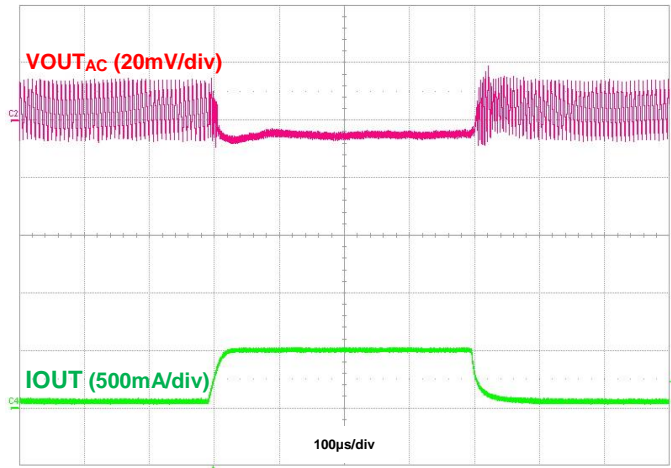

Figure 18. Load Transient, $I_{OUT} = 50\text{mA}$ to 500mA to 50mA

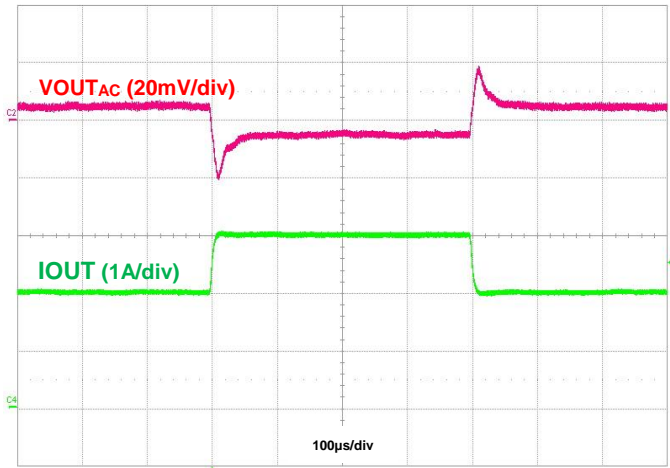

Figure 19. Load Transient, $I_{OUT} = 2\text{A}$ to 3A to 2A

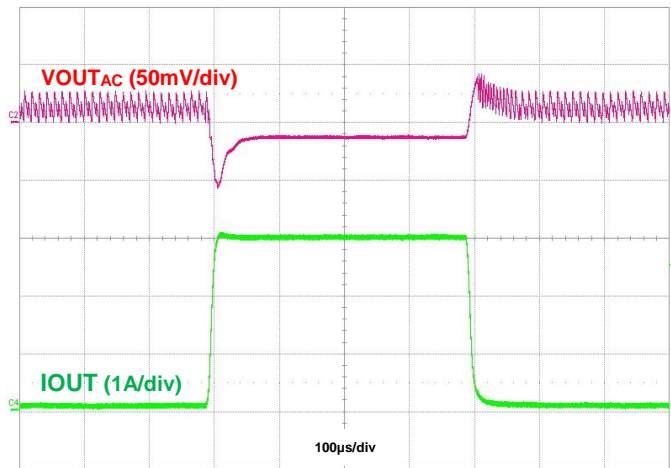

Figure 20. Load Transient, $I_{OUT} = 50\text{mA}$ to 3A to 50mA

Typical Performance Characteristics (AP61300/AP61302 @ $T_A = +25^\circ\text{C}$, $V_{IN} = 5\text{V}$, $V_{OUT} = 1.8\text{V}$, BOM = Table 1, PWM, unless otherwise specified.)

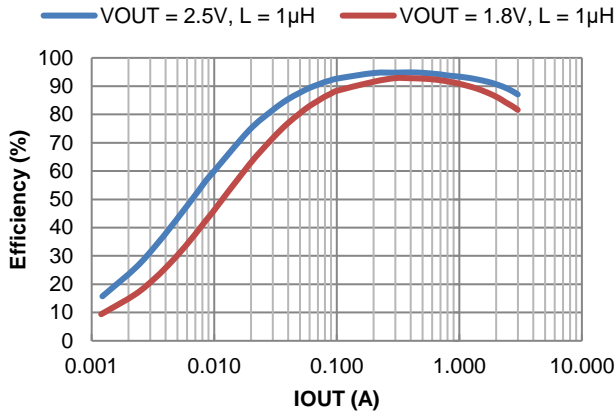

Figure 21. Efficiency vs. Output Current, $V_{IN} = 3.3\text{V}$

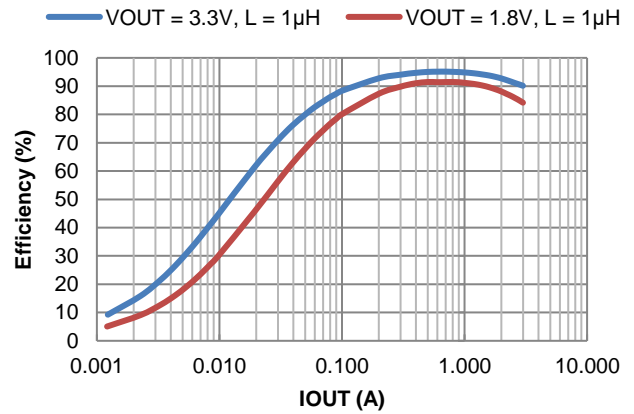

Figure 22. Efficiency vs. Output Current, $V_{IN} = 5\text{V}$

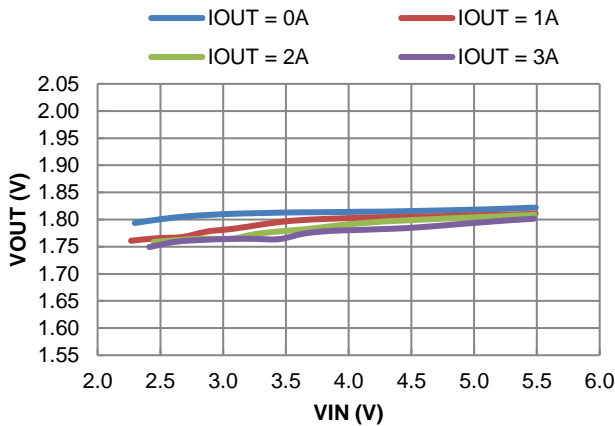

Figure 23. Line Regulation

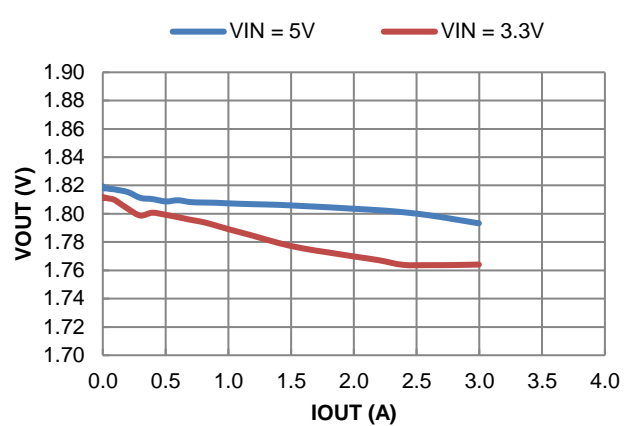

Figure 24. Load Regulation

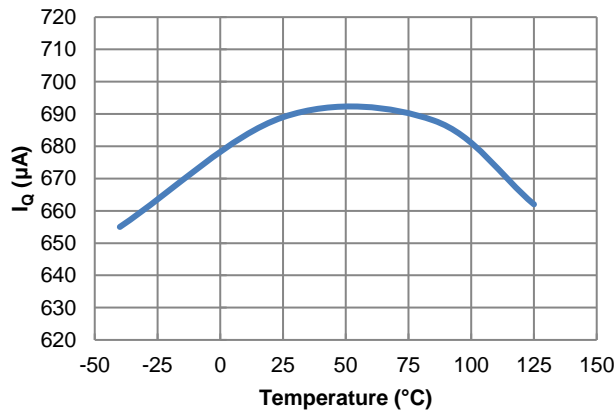

Figure 25. I_Q vs. Temperature

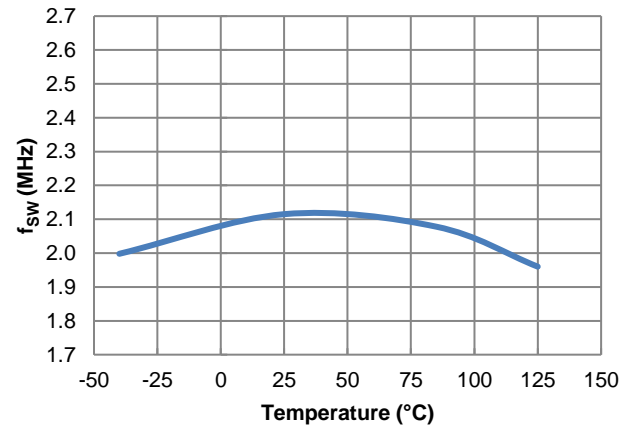

Figure 26. f_{sw} vs. Temperature, $I_{OUT} = 0\text{A}$

Typical Performance Characteristics (AP61300/AP61302 @ $T_A = +25^\circ\text{C}$, $V_{IN} = 5\text{V}$, $V_{OUT} = 1.8\text{V}$, BOM = Table 1, PWM, unless otherwise specified.) (continued)

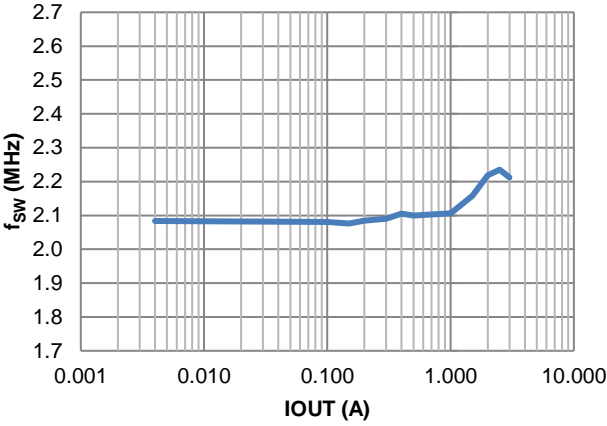

Figure 27. f_{sw} vs. Load

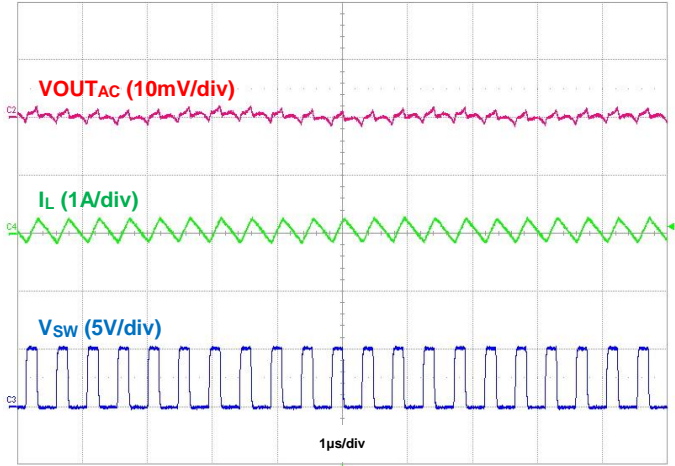

Figure 28. Output Voltage Ripple, IOUt = 50mA

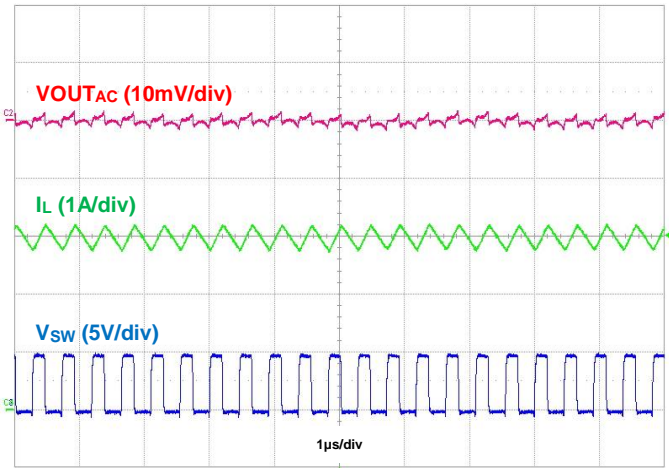

Figure 29. Output Voltage Ripple, IOUt = 3A

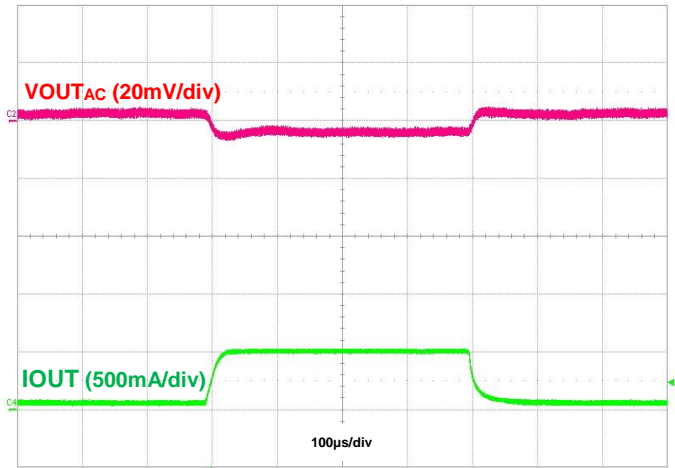

Figure 30. Load Transient, IOUt = 50mA to 500mA to 50mA

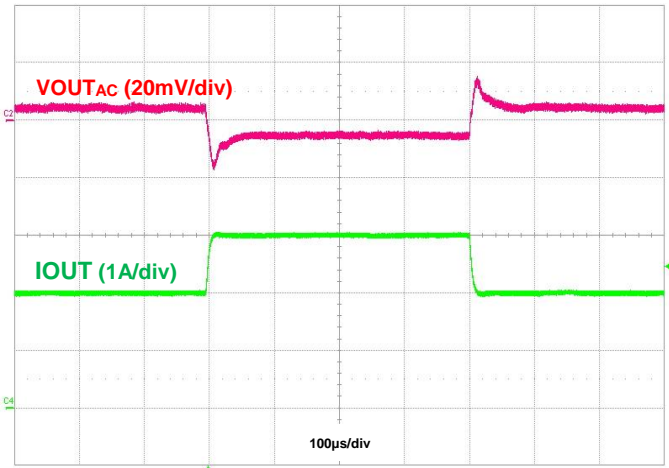

Figure 31. Load Transient, IOUt = 2A to 3A to 2A

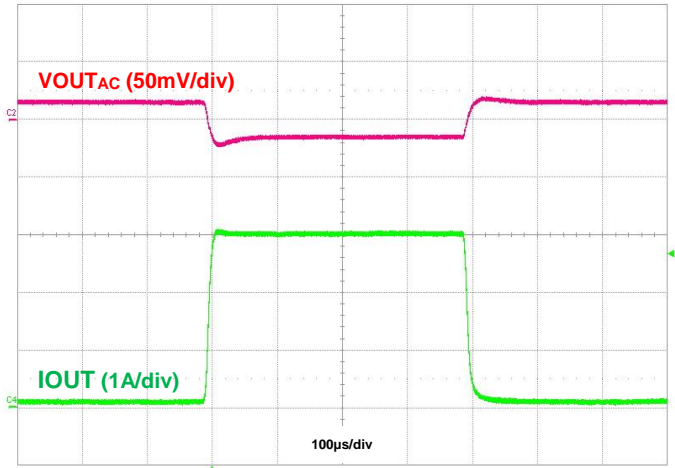

Figure 32. Load Transient, IOUt = 50mA to 3A to 50mA

Typical Performance Characteristics (AP61300 @ $T_A = +25^\circ\text{C}$, $V_{IN} = 5\text{V}$, $V_{OUT} = 1.8\text{V}$, BOM = Table 1, unless otherwise specified.)

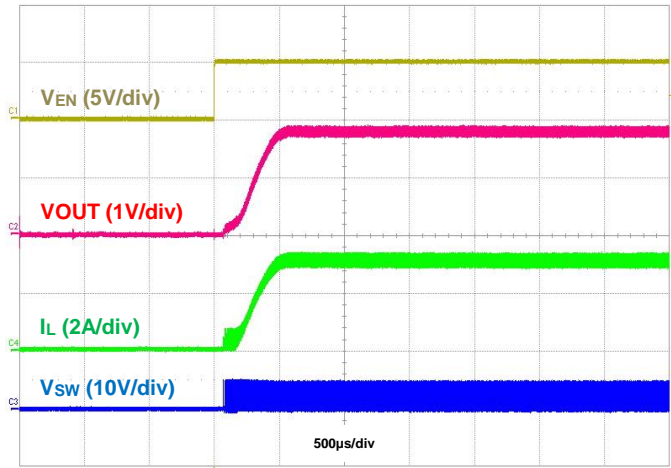

Figure 33. Startup Using EN, IOU = 3A

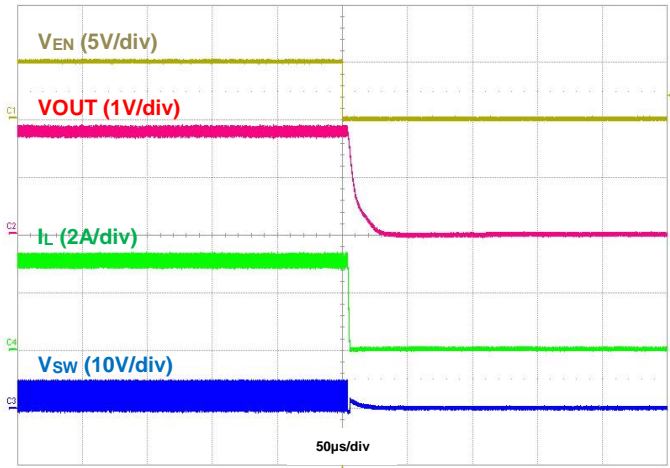

Figure 34. Shutdown Using EN, IOU = 3A

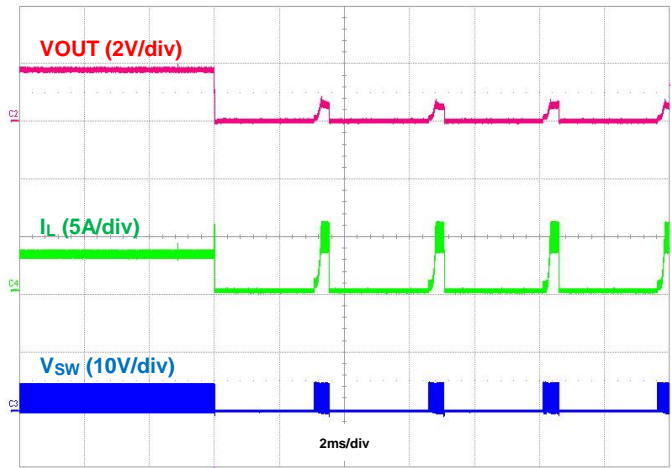

Figure 35. Output Short Protection, IOU = 3A

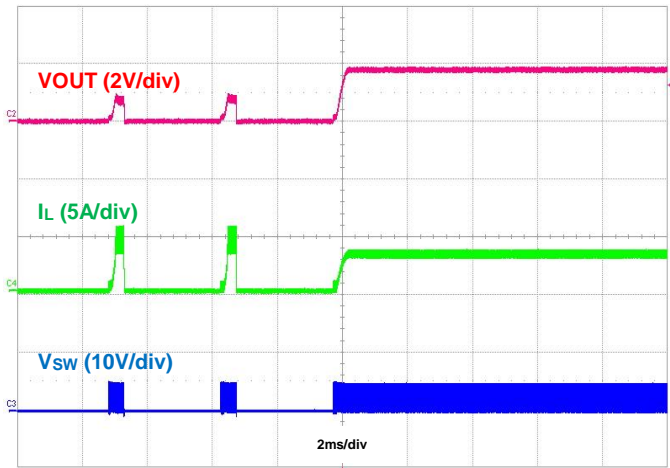

Figure 36. Output Short Recovery, IOU = 3A

Typical Performance Characteristics (AP61302 @ $T_A = +25^\circ\text{C}$, $V_{IN} = 5\text{V}$, $V_{OUT} = 1.8\text{V}$, BOM = Table 1, unless otherwise specified.)

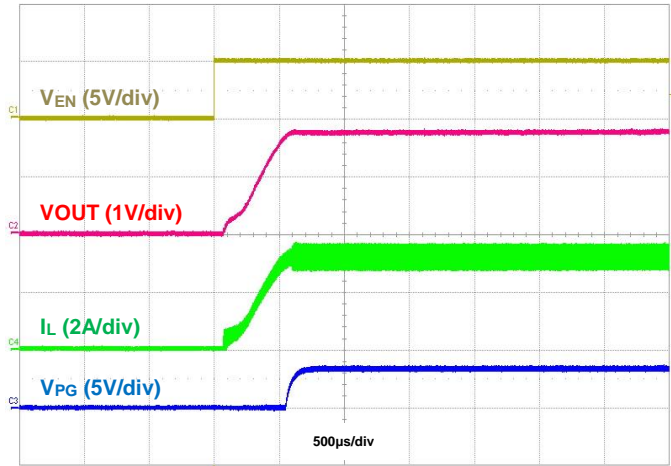

Figure 37. Startup Using EN, IOUT = 3A

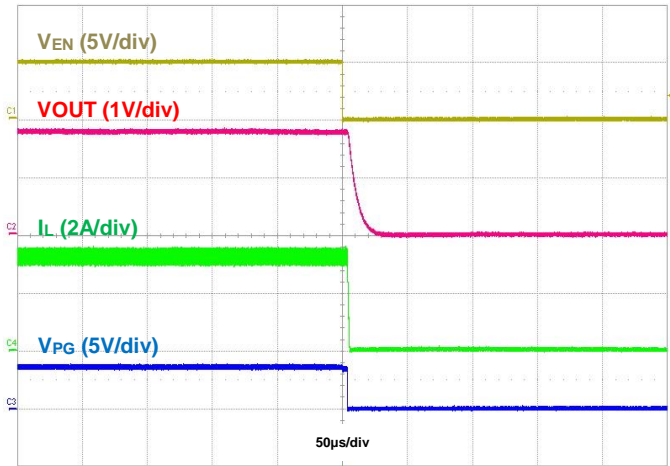

Figure 38. Shutdown Using EN, IOUT = 3A

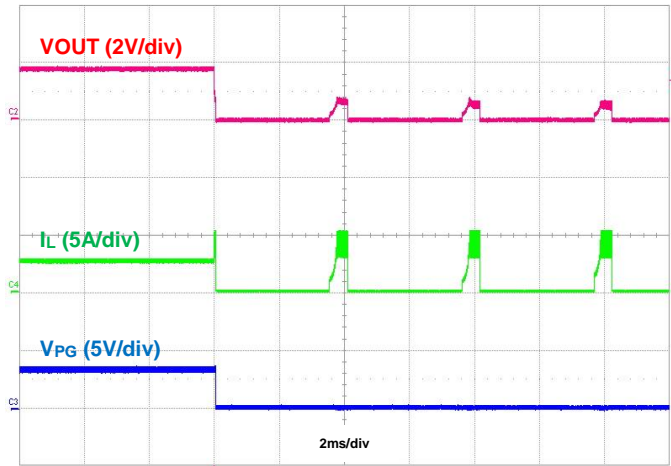

Figure 39. Output Short Protection, IOUT = 3A

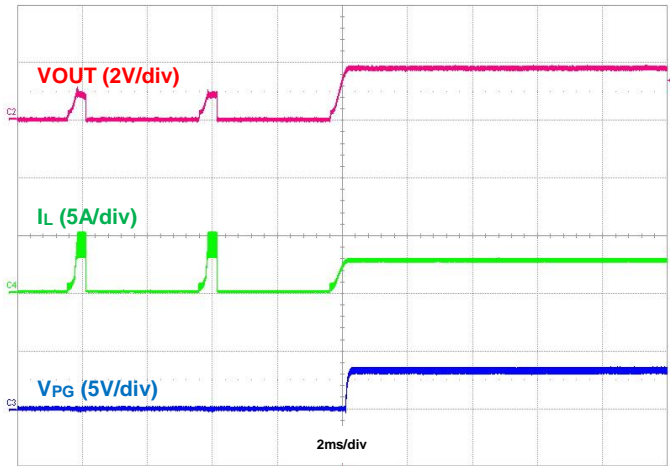

Figure 40. Output Short Recovery, IOUT = 3A

Application Information

1 Pulse Width Modulation (PWM) Operation

The AP61300/AP61302 device is a 2.4V-to-5.5V input, 3A output, fully integrated synchronous buck converter. Refer to the block diagram in Figure 5. The device employs constant on-time control to provide fast transient response and easy loop stabilization. At the beginning of each cycle, the one-shot pulse turns on the high-side power MOSFET, Q1, for a fixed on-time, t_{ON} . This one-shot on-pulse timing is calculated by the converter's input voltage and output voltage to maintain a pseudo-fixed frequency over the input voltage range. When Q1 is on, the inductor current rises linearly and the device charges the output capacitor. Q1 turns off after the fixed on-time expires, and the low-side power MOSFET, Q2, turns on. Once the output voltage drops below the output regulation, Q2 turns off. The one-shot timer is then reset and Q1 turns on again. The on-time is inversely proportional to the input voltage and directly proportional to the output voltage. It is calculated by the following equation:

$$t_{ON} = \frac{V_{OUT}}{V_{IN} \cdot f_{sw}} \quad \text{Eq. 1}$$

Where:

- V_{IN} is the input voltage
- V_{OUT} is the output voltage
- f_{sw} is the switching frequency

The off-time duration is t_{OFF} and starts after the on-time expires. The off-time expires when the feedback voltage decreases below the reference voltage, which then triggers the on-time duration to start again. The minimum off-time is 70ns typical.

2 Pulse Frequency Modulation (PFM) Operation

The AP61300/AP61302 can be programmed to enter PFM operation at light load conditions for high efficiency. During light load conditions, the regulator automatically reduces the switching frequency. As the output current decreases, so too does the inductor current. The inductor current, I_L , eventually reaches 0A, marking the boundary between Continuous Conduction Mode (CCM) and Discontinuous Condition Mode (DCM). During this time, both Q1 and Q2 are off, and the load current is provided only by the output capacitor. When V_{FB} becomes lower than 0.6V, the next cycle begins, and Q1 turns on. Because the AP61300/AP61302 can work in PFM during light load conditions, it can achieve power efficiency of up to 84% at a 5mA load condition.

Likewise, as the output load increases from light load to heavy load, the switching frequency increases to maintain the regulation of the output voltage. The transition point between light and heavy load conditions can be calculated using the following equation:

$$I_{LOAD} = \left(\frac{V_{IN} - V_{OUT}}{2L} \right) \cdot t_{ON} \quad \text{Eq. 2}$$

Where:

- L is the inductor value

The quiescent current of AP61300/AP61302 is 19µA typical under a no-load, non-switching condition.

Application Information (continued)

3 Enable

When disabled, the device shutdown supply current is only 0.1µA. When applying a voltage greater than the EN logic high threshold (typical 0.91V, rising), the AP61300/AP61302 enables all functions and the device initiates the soft-start phase. The AP61300/AP61302 has a built-in 0.5ms soft-start time to prevent output voltage overshoot and inrush current. When the EN voltage falls below its logic low threshold (typical 0.83V, falling), the internal SS voltage discharges to ground and device operation disables.

The device operates in PFM when a logic high voltage is applied to the EN pin greater than $V_{IN} - 200mV$. Tying the EN pin to the VIN pin is sufficient to achieve this threshold condition.

The device operates in PWM regardless of output load when a logic high voltage is applied to the EN pin less than $V_{IN} - 200mV$. Using an external resistive divider to create a difference in voltage between the VIN and EN pins is sufficient to achieve this threshold condition.

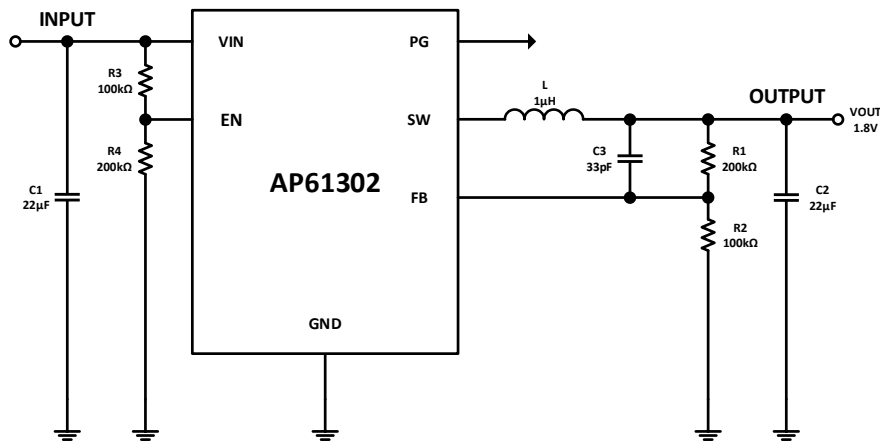

Figure 41. Example Application Circuit for Forced PWM Operation

4 Power-Good (PG) Indicator (AP61302)

The PG pin of AP61302 is an open-drain output that is actively held low during the soft-start period until the output voltage reaches 95% of its target value. When the output voltage is outside of its regulation by $\pm 10\%$, PG pulls low until the output returns within 5% of its set value. The PG rising edge transition is delayed by 40µs. The PG pin is connected to VIN through an internal 5MΩ pull-up resistor.

5 Undervoltage Lockout (UVLO) and Input Overvoltage Protection (OVP)

Undervoltage lockout is implemented to protect the IC from insufficient input voltages. The AP61300/AP61302 disables if the input voltage falls below 2.2V. In this UVLO event, both the high-side and low-side power MOSFETs turn off and the 125Ω active discharge enables to discharge the output voltage to ground.

Similarly, input overvoltage protection is implemented to protect the IC from excess input voltages. The AP61300/AP61302 disables if the input voltage rises above 6.3V. In this OVP event, both the high-side and low-side power MOSFETs turn off and the 125Ω active discharge enables to discharge the output voltage to ground.

Application Information (continued)

6 Overcurrent Protection (OCP)

The AP6130Q/AP61302 has cycle-by-cycle valley current limit protection by sensing the current through the internal low-side power MOSFET, Q2. While Q2 is on, the internal sensing circuitry monitors its conduction current. The overcurrent limit has a corresponding voltage limit, V_{LIMIT} . When the voltage between GND and SW is lower than V_{LIMIT} due to excessive current through Q2, the OCP triggers, and the controller turns off Q2. During this time, both Q1 and Q2 remain off. A new switching cycle begins only when the voltage between GND and SW rises above V_{LIMIT} . If Q2 consistently hits the valley current limit for 0.6ms, the buck converter enters hiccup mode and shuts down. After 3.4ms of down time, the buck converter restarts powering up. Hiccup mode reduces the power dissipation in the overcurrent condition.

The AP61300/AP61302 also has cycle-by-cycle peak current limit protection by sensing the current through the internal high-side power MOSFET, Q1, through a similar mechanism as the cycle-by-cycle valley current limit protection.

Because the $R_{DS(ON)}$ values of the power MOSFETs increase with temperature, V_{LIMIT} has a temperature coefficient of 0.4%/°C to compensate for the temperature dependency of $R_{DS(ON)}$.

7 Thermal Shutdown (TSD)

If the junction temperature of the device reaches the thermal shutdown limit of +160°C, the AP61300/AP61302 shuts down both its high-side and low-side power MOSFETs. When the junction temperature reduces to the required level (+130°C typical), the device initiates a normal power-up cycle with soft-start.

8 Power Derating Characteristics

To prevent the regulator from exceeding the maximum recommended operating junction temperature, some thermal analysis is required. The regulator's temperature rise is given by:

$$T_{RISE} = PD \cdot (\theta_{JA}) \tag{Eq. 3}$$

Where:

- PD is the power dissipated by the regulator
- θ_{JA} is the thermal resistance from the junction of the die to the ambient temperature

The junction temperature, T_J , is given by:

$$T_J = T_A + T_{RISE} \tag{Eq. 4}$$

Where:

- T_A is the ambient temperature of the environment

For the SOT563 package, the θ_{JA} is 141°C/W. The actual junction temperature should not exceed the maximum recommended operating junction temperature of +125°C when considering the thermal design.

Application Information (continued)

9 Setting the Output Voltage

The AP61300/AP61302 has adjustable output voltages, starting from 0.6V, using an external resistive divider. The resistor values of the feedback network are selected based on a design trade-off between efficiency and output voltage accuracy. There is less current consumption in the feedback network for high resistor values, which improves efficiency at light loads. However, values too high cause the device to be more susceptible to noise affecting its output voltage accuracy. R2 can be determined by the following equation:

$$R2 = \frac{0.6 \cdot R1}{VOUT - 0.6V} \quad \text{Eq. 5}$$

Table 1 shows a list of recommended component selections for common AP61300/AP61302 output voltages referencing Figure 1 and Figure 2.

Table 1. Recommended Component Selections

AP61300/AP61302							
Output Voltage (V)	R1 (kΩ)	R2 (kΩ)	L (μH)	C1 (μF)	C2 (μF)	C3 (pF)	
						AP61300	AP61302
1.0	200.0	301.0	1.0	22	22	OPEN	33
1.2	200.0	200.0	1.0	22	22	OPEN	33
1.5	200.0	133.0	1.0	22	22	OPEN	33
1.8	200.0	100.0	1.0	22	22	OPEN	33
2.5	200.0	63.2	1.0	22	22	OPEN	33
3.3	200.0	44.2	1.0	22	22	OPEN	33

10 Inductor

Calculating the inductor value is a critical factor in designing a buck converter. For most designs, the following equation can be used to calculate the inductor value:

$$L = \frac{VOUT \cdot (VIN - VOUT)}{VIN \cdot \Delta I_L \cdot f_{sw}} \quad \text{Eq. 6}$$

Where:

- ΔI_L is the inductor current ripple
- f_{sw} is the buck converter switching frequency

For AP61300/AP61302, choose ΔI_L to be 30% to 50% of the maximum load current of 3A.

The inductor peak current is calculated by:

$$I_{LPEAK} = I_{LOAD} + \frac{\Delta I_L}{2} \quad \text{Eq. 7}$$

Peak current determines the required saturation current rating, which influences the size of the inductor. Saturating the inductor decreases the converter efficiency while increasing the temperatures of the inductor and the internal power MOSFETs. Therefore, choosing an inductor with the appropriate saturation current rating is important. For most applications, it is recommended to select an inductor of approximately 0.47μH to 2.2μH with a DC current rating of at least 35% higher than the maximum load current. For highest efficiency, the inductor's DC resistance should be less than 30mΩ. Use a larger inductance for improved efficiency under light load conditions.

Application Information (continued)

11 Input Capacitor

The input capacitor reduces both the surge current drawn from the input supply as well as the switching noise from the device. The input capacitor must sustain the ripple current produced during the on-time of Q1. It must have a low ESR to minimize power dissipation due to the RMS input current.

The RMS current rating of the input capacitor is a critical parameter and must be higher than the RMS input current. As a rule of thumb, select an input capacitor with a RMS current rating greater than half of the maximum load current.

Due to large di/dt through the input capacitor, electrolytic or ceramic capacitors with low ESR should be used. If using a tantalum capacitor, it must be surge protected or else capacitor failure could occur. Using a ceramic capacitor of 10 μ F or greater is sufficient for most applications.

12 Output Capacitor

The output capacitor keeps the output voltage ripple small, ensures feedback loop stability, and reduces both the overshoots and undershoots of the output voltage during load transients. During the first few microseconds of an increasing load transient, the converter recognizes the change from steady-state and sets the off-time to minimum to supply more current to the load. However, the inductor limits the change to increasing current depending on its inductance. Therefore, the output capacitor supplies the difference in current to the load during this time. Likewise, during the first few microseconds of a decreasing load transient, the converter recognizes the change from steady-state and increases the off-time to reduce the current supplied to the load. However, the inductor limits the change in decreasing current as well. Therefore, the output capacitor absorbs the excess current from the inductor during this time.

The effective output capacitance, C_{OUT} , requirements can be calculated from the equations below.

The ESR of the output capacitor dominates the output voltage ripple. The amount of ripple can be calculated by:

$$V_{OUT_{Ripple}} = \Delta I_L \cdot \left(ESR + \frac{1}{8 \cdot f_{sw} \cdot C_{OUT}} \right) \quad \text{Eq. 8}$$

Output capacitors with large capacitance and low ESR are the best option. For most applications, a total capacitance of 22 μ F using ceramic capacitors is sufficient. To meet the load transient requirements, the calculated C_{OUT} should satisfy the following inequality:

$$C_{OUT} > \max \left(\frac{L \cdot I_{Trans}^2}{\Delta V_{Overshoot} \cdot V_{OUT}}, \frac{L \cdot I_{Trans}^2}{\Delta V_{Undershoot} \cdot (V_{IN} - V_{OUT})} \right) \quad \text{Eq. 9}$$

Where:

- I_{Trans} is the load transient
- $\Delta V_{Overshoot}$ is the maximum output overshoot voltage
- $\Delta V_{Undershoot}$ is the maximum output undershoot voltage

Layout

PCB Layout

1. The AP61300/AP61302 works at 3A load current so heat dissipation is a major concern in the layout of the PCB. 2oz copper for both the top and bottom layers is recommended.
2. Place the input capacitors as closely across VIN and GND as possible.
3. Place the inductor as close to SW as possible.
4. Place the output capacitors as close to GND as possible.
5. Place the feedback components as close to FB as possible.
6. If using four or more layers, use at least the 2nd and 3rd layers as GND to maximize thermal performance.
7. Add as many vias as possible around both the GND pin and under the GND plane for heat dissipation to all the GND layers.
8. Add as many vias as possible around both the VIN pin and under the VIN plane for heat dissipation to all the VIN layers.
9. See Figure 42 and Figure 43 for more details.

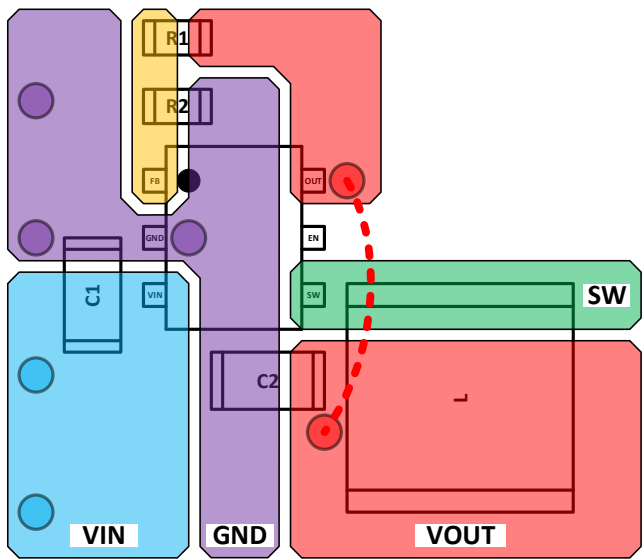

Figure 42. Recommended AP61300 PCB Layout

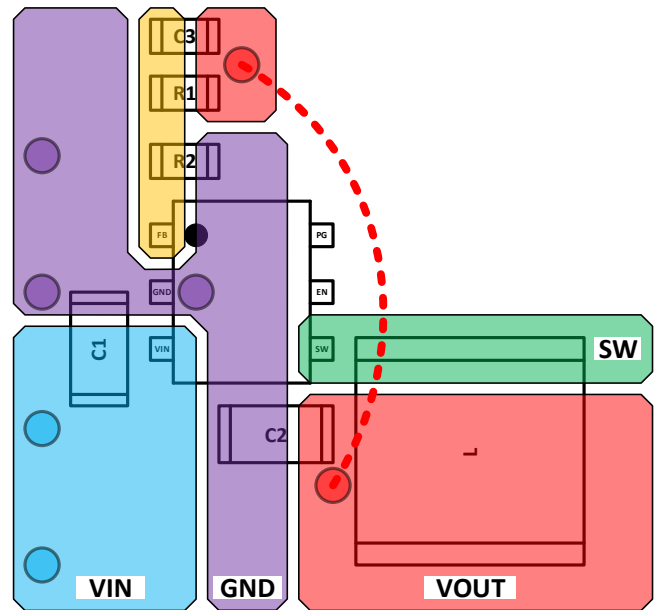
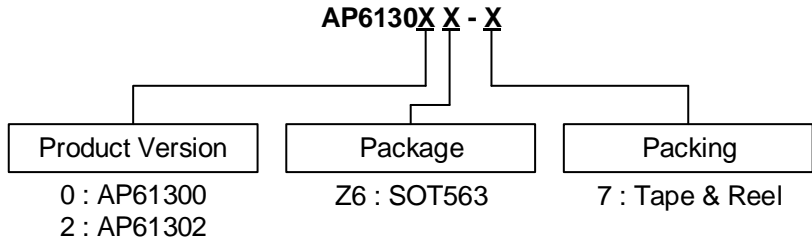

Figure 43. Recommended AP61302 PCB Layout

Ordering Information



Part Number	Function	Package	Package Code	Tape and Reel	
				Quantity	Part Number Suffix
AP61300Z6-7	-	SOT563	Z6	3000	-7
AP61302Z6-7	PG	SOT563	Z6	3000	-7

Marking Information

SOT563

(Top View)

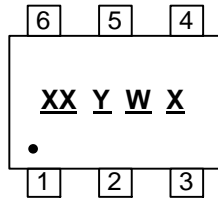

- XX : Identification Code
- Y : Year 0~9
- W : Week : A~Z : 1~26 week;
a~z : 27~52 week; z represents 52 and 53 week
- X : Internal Code

Part Number	Package	Identification Code
AP61300Z6-7	SOT563	HP
AP61302Z6-7	SOT563	HR

Package Outline Dimensions

Please see <http://www.diodes.com/package-outlines.html> for the latest version.

SOT563

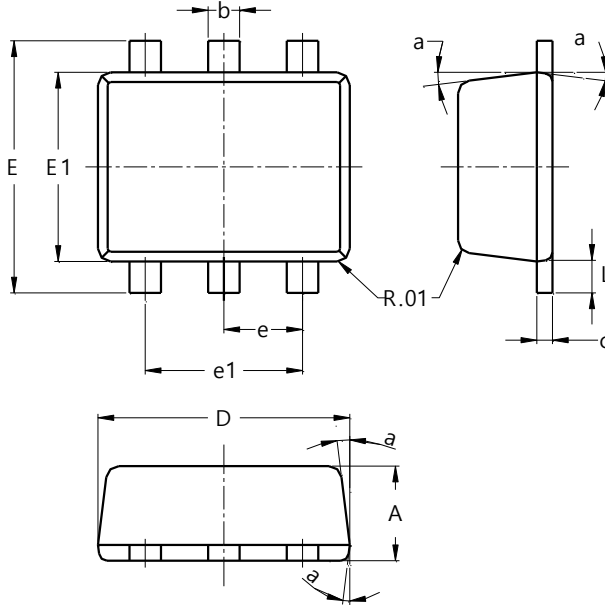

SOT563			
Dim	Min	Max	Typ
A	0.55	0.60	--
b	0.15	0.30	0.20
c	0.10	0.18	0.11
D	1.50	1.70	1.60
E	1.55	1.70	1.60
E1	1.10	1.25	1.20
e	--	--	0.50
e1	0.90	1.10	1.00
L	0.10	0.30	0.20
a	8°	9°	7°
All Dimensions in mm			

Suggested Pad Layout

Please see <http://www.diodes.com/package-outlines.html> for the latest version.

SOT563

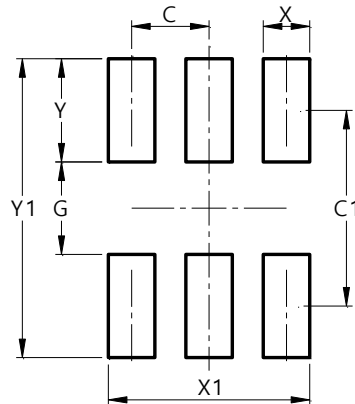

Dimensions	Value (in mm)
C	0.500
C1	1.270
G	0.600
X	0.300
X1	1.300
Y	0.670
Y1	1.940

Mechanical Data

- Moisture Sensitivity: Level 1 per J-STD-020
- Terminals: Finish – Matte Tin Plated Leads, Solderable per MIL-STD-202, Method 208 ③
- Weight: 0.003 grams (Approximate)

IMPORTANT NOTICE

1. DIODES INCORPORATED (Diodes) AND ITS SUBSIDIARIES MAKE NO WARRANTY OF ANY KIND, EXPRESS OR IMPLIED, WITH REGARDS TO ANY INFORMATION CONTAINED IN THIS DOCUMENT, INCLUDING, BUT NOT LIMITED TO, THE IMPLIED WARRANTIES OF MERCHANTABILITY, FITNESS FOR A PARTICULAR PURPOSE OR NON-INFRINGEMENT OF THIRD PARTY INTELLECTUAL PROPERTY RIGHTS (AND THEIR EQUIVALENTS UNDER THE LAWS OF ANY JURISDICTION).
2. The Information contained herein is for informational purpose only and is provided only to illustrate the operation of Diodes' products described herein and application examples. Diodes does not assume any liability arising out of the application or use of this document or any product described herein. This document is intended for skilled and technically trained engineering customers and users who design with Diodes' products. Diodes' products may be used to facilitate safety-related applications; however, in all instances customers and users are responsible for (a) selecting the appropriate Diodes products for their applications, (b) evaluating the suitability of Diodes' products for their intended applications, (c) ensuring their applications, which incorporate Diodes' products, comply the applicable legal and regulatory requirements as well as safety and functional-safety related standards, and (d) ensuring they design with appropriate safeguards (including testing, validation, quality control techniques, redundancy, malfunction prevention, and appropriate treatment for aging degradation) to minimize the risks associated with their applications.
3. Diodes assumes no liability for any application-related information, support, assistance or feedback that may be provided by Diodes from time to time. Any customer or user of this document or products described herein will assume all risks and liabilities associated with such use, and will hold Diodes and all companies whose products are represented herein or on Diodes' websites, harmless against all damages and liabilities.
4. Products described herein may be covered by one or more United States, international or foreign patents and pending patent applications. Product names and markings noted herein may also be covered by one or more United States, international or foreign trademarks and trademark applications. Diodes does not convey any license under any of its intellectual property rights or the rights of any third parties (including third parties whose products and services may be described in this document or on Diodes' website) under this document.
5. Diodes' products are provided subject to Diodes' Standard Terms and Conditions of Sale (<https://www.diodes.com/about/company/terms-and-conditions/terms-and-conditions-of-sales/>) or other applicable terms. This document does not alter or expand the applicable warranties provided by Diodes. Diodes does not warrant or accept any liability whatsoever in respect of any products purchased through unauthorized sales channel.
6. Diodes' products and technology may not be used for or incorporated into any products or systems whose manufacture, use or sale is prohibited under any applicable laws and regulations. Should customers or users use Diodes' products in contravention of any applicable laws or regulations, or for any unintended or unauthorized application, customers and users will (a) be solely responsible for any damages, losses or penalties arising in connection therewith or as a result thereof, and (b) indemnify and hold Diodes and its representatives and agents harmless against any and all claims, damages, expenses, and attorney fees arising out of, directly or indirectly, any claim relating to any noncompliance with the applicable laws and regulations, as well as any unintended or unauthorized application.
7. While efforts have been made to ensure the information contained in this document is accurate, complete and current, it may contain technical inaccuracies, omissions and typographical errors. Diodes does not warrant that information contained in this document is error-free and Diodes is under no obligation to update or otherwise correct this information. Notwithstanding the foregoing, Diodes reserves the right to make modifications, enhancements, improvements, corrections or other changes without further notice to this document and any product described herein. This document is written in English but may be translated into multiple languages for reference. Only the English version of this document is the final and determinative format released by Diodes.
8. Any unauthorized copying, modification, distribution, transmission, display or other use of this document (or any portion hereof) is prohibited. Diodes assumes no responsibility for any losses incurred by the customers or users or any third parties arising from any such unauthorized use.
9. This Notice may be periodically updated with the most recent version available at <https://www.diodes.com/about/company/terms-and-conditions/important-notice>

DIODES is a trademark of Diodes Incorporated in the United States and other countries.
The Diodes logo is a registered trademark of Diodes Incorporated in the United States and other countries.
© 2022 Diodes Incorporated. All Rights Reserved.

www.diodes.com