

# AN7470

## FM Stereo Multiplex Demodulator

### ■ Outline

The AN7470 is an integrated circuit developed for FM stereo multiplex demodulation used for high class stereo FM tuner.

### ■ Features

- Provided with forced and automatic mono/stereo switching
- Low shock noise during mono/stereo switching
- Low distortion with post amplifier

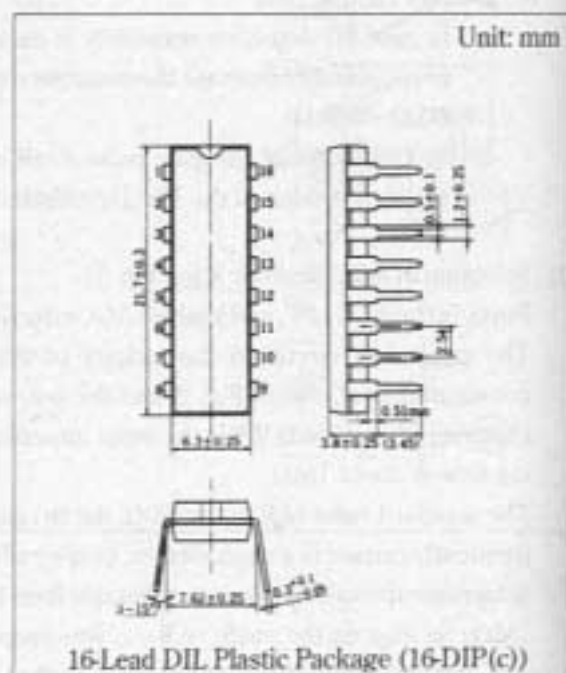

### ■ Pin Descriptions

Pin No.	Pin Name	Pin No.	Pin Name
1	V <sub>CC</sub>	9	Stereo Indicator and VCO Freq. Monitor
2	Composite Signal Input	10, 11	Pilot Detection Low-pass Filter
3	Buffer Amp. Output	12	Pilot Signal Input
4	L Ch. Amp. Feedback	13	PLL Low-pass Filter
5	R Ch. Amp. Feedback	14	PLL Low-pass Filter
6	R Ch. Amp. Output	15	VCO RC Time Constant
7	L Ch. Amp. Output	16	Forced Mono. VCO Killer
8	GND		

### ■ Block Diagram

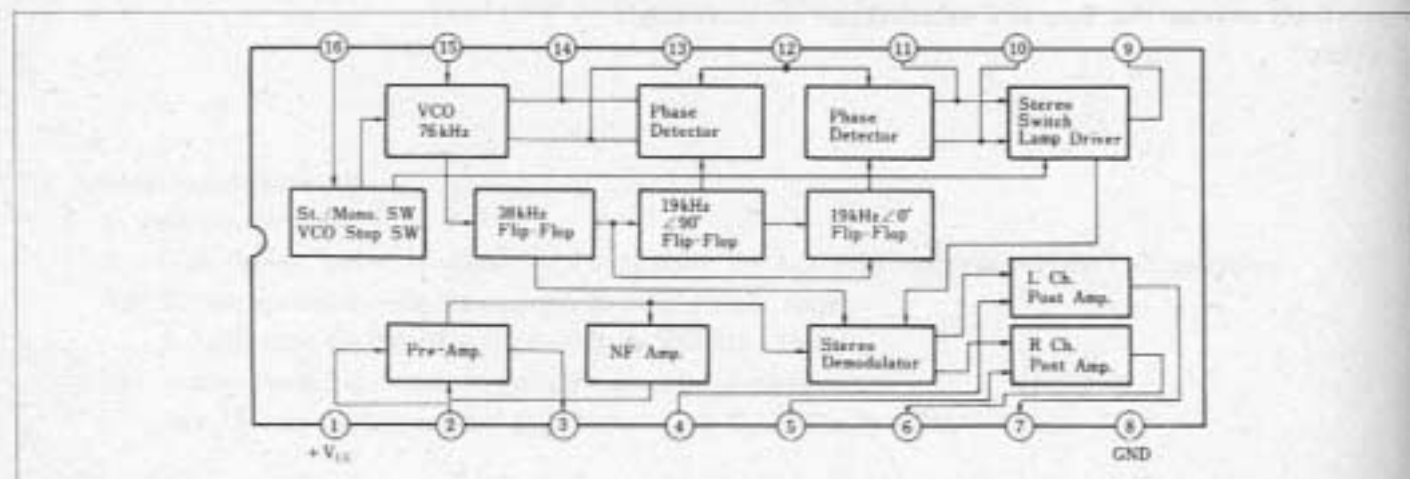

### ■ Absolute Maximum Ratings (Ta = 25°C)

Item	Symbol	Rating	Unit
Supply Voltage	V <sub>CC</sub>	14.4	V
Power Dissipation (Ta = 75°C)	P <sub>D</sub>	430	mW
Operating Ambient Temperature	T <sub>opr</sub>	-20 ~ +75	°C
Storage Temperature	T <sub>stg</sub>	-55 ~ +150	°C

### ■ Electrical Characteristics (V<sub>CC</sub> = 12V, Ta = 25°C)

Item	Symbol	Test Circuit	Condition	min.	typ.	max.	Unit
Circuit Current	Lamp OFF	I <sub>1</sub>	Without input signal (Lamp OFF)	10	18	28	mA
	Lamp ON	I <sub>1</sub>	Pilot signal, V <sub>P</sub> = 30mV (Lamp ON)		20		mA
Separation	Sep	1	f <sub>in</sub> = 1kHz, V <sub>i(L-R)</sub> = 270mV <sub>rms</sub> L or R = 90%, V <sub>P</sub> = 30mV <sub>rms</sub> Pilot = 10%	45	55		dB
Voltage Gain (Mono.)	G <sub>V</sub>	1		10	12	14	dB
Channel Balance	CB	1		-1	0	1	dB
Total Harmonic Distortion	Stereo	THD	f <sub>m</sub> = 1kHz, V <sub>i</sub> = 300mV <sub>rms</sub>		0.04	0.1	%
	Mono.	THD			0.02	0.1	%
Carrier Leakage	CL		V <sub>i(L-R)</sub> = 270mV <sub>rms</sub> , f <sub>m</sub> = 1kHz L + R = 90%, Pilot = 10%	20	26		dB
Pilot Signal ON Voltage	V <sub>P(ON)</sub>	1	Pilot signal 19kHz	6	12	20	mV <sub>rms</sub>
Capture Range	CR	1	Pilot signal 19kHz, V <sub>P</sub> = 30mV <sub>rms</sub>	±1.5	±3		%
Signal to Noise Ratio	S/N	1	f <sub>m</sub> = 1kHz, V <sub>i</sub> = 300mV <sub>rms</sub> , R <sub>e</sub> = 0	76	85		dB

Note) typ. is a referenced value.

### Test Circuit 1

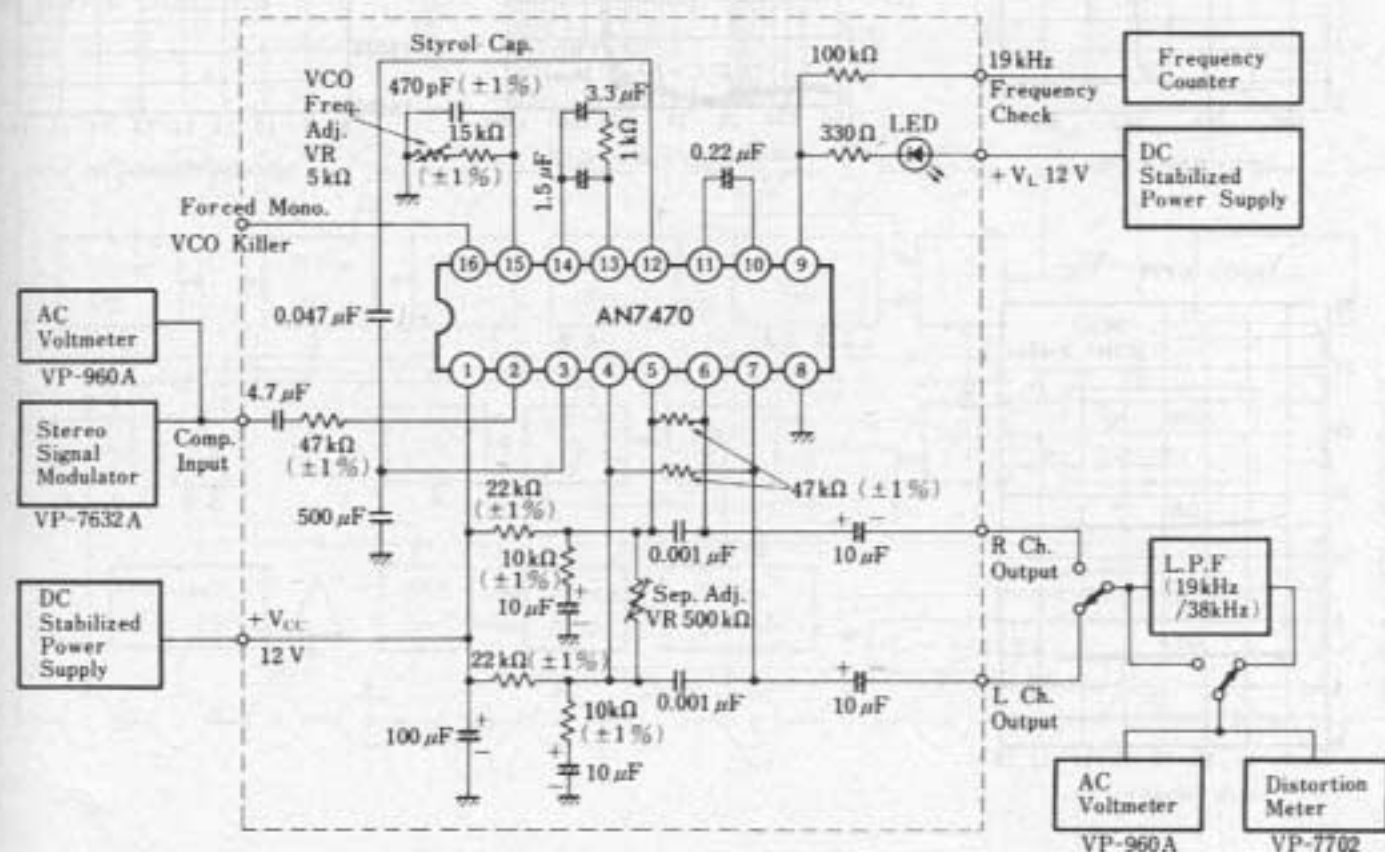

Sep -  $V_i$

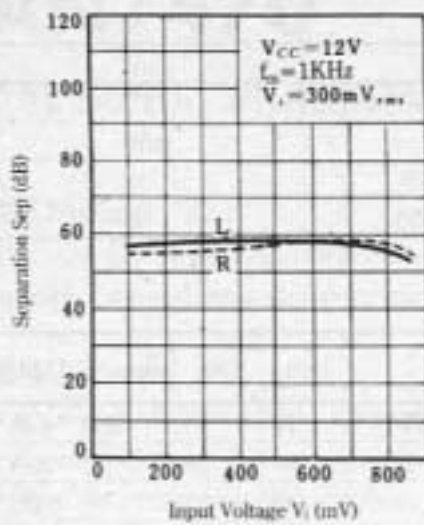

Sep -  $f_m$

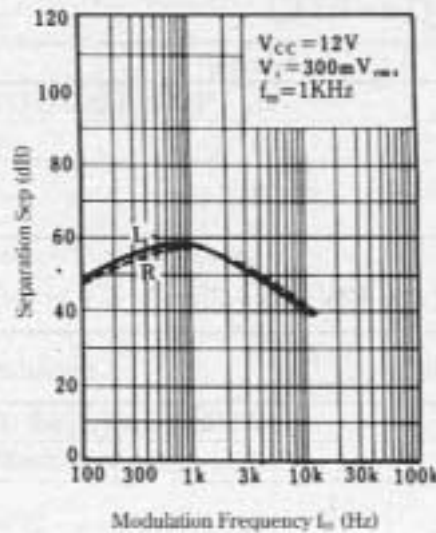

THD (Mono) -  $V_i$

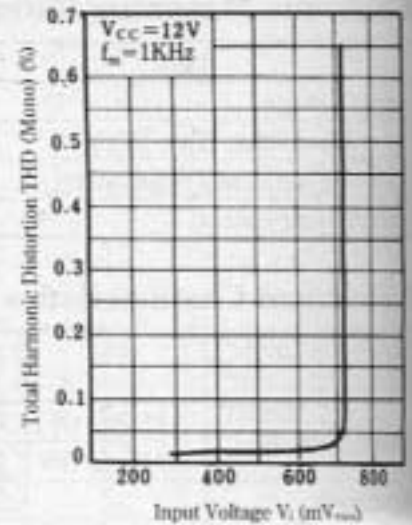

THD -  $V_i$

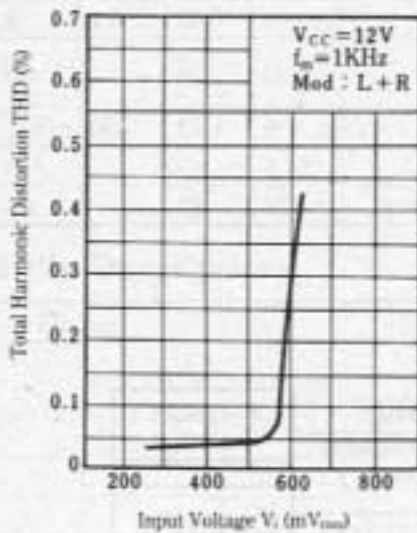

THD -  $f_m$

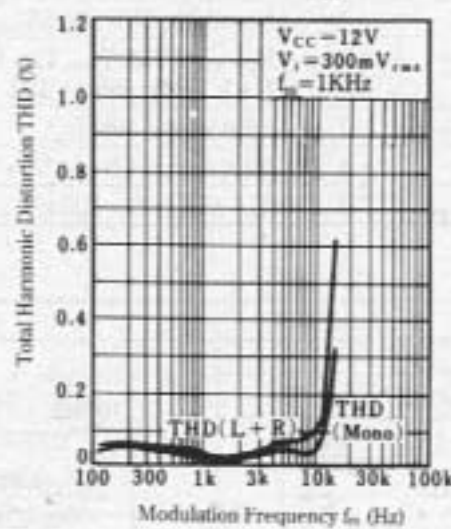

$f_{VCO}$  -  $V_{CC}$

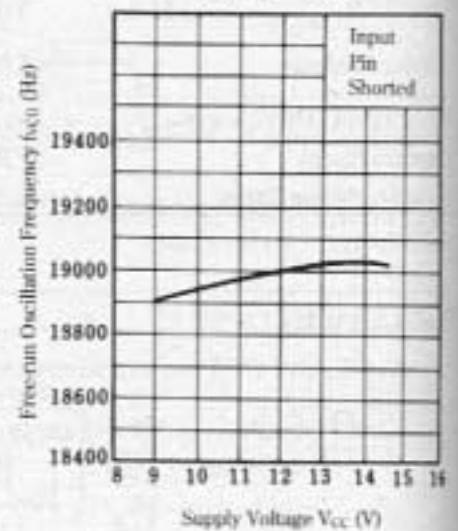

$V_{P(ON/OFF)}$  -  $V_{CC}$

