

1-Bit, 10MHz, 2nd-Order, Isolated Delta-Sigma Modulator

Check for Samples: [AMC1203](#)

FEATURES

- 16-Bit Resolution
- SNR: 80.5dB min
- THD: –88dB max (AMC1203B)
- ±280mV Input Range with +5V Supply
- Internal 2.5V Reference Voltage: 1% Accuracy
- Gain Error: ±1% (AMC1203B)
- UL1577, IEC60747-5-2 (VDE0884, Rev. 2), and IEC61010-1 Approved
 - Isolation: 4000V_{PEAK}, Working Voltage: 560V
 - Transient Immunity: 15kV/μs
- Typical 25-Year Life at Rated Working Voltage (see Application Report [SLLA197](#))
- Specified Temperature Range: –40°C to +105°C

APPLICATIONS

- Shunt Based Current Sensing in:
 - Motor Control
 - Uninterruptible Power Supplies
 - Power Inverters
 - Industrial Process Control

DESCRIPTION

The AMC1203 is a 1-bit, 10MHz, isolated delta-sigma ($\Delta\Sigma$) modulator with an output buffer separated from the input interface circuitry by a silicon dioxide (SiO₂) isolation barrier. This barrier provides galvanic isolation of up to 4000V_{PEAK}. Used in conjunction with isolated power supplies, these devices prevent noise currents on a data bus or other circuits from entering the local ground and interfering with or damaging sensitive circuitry.

The AMC1203 modulator operates from a +5V supply with a dynamic range of 95dB. The differential inputs are ideal for direct connection to shunt resistors or other low-level signal sources. With the appropriate digital filter and modulator rate, the device can be used to achieve 16-bit analog-to-digital (A/D) conversion with no missing codes. An effective resolution of 14 bits and an SNR of 85dB (typical) can be maintained with a sinc³ filter with a decimation ratio of 256.

The modulator output is translated to a balanced signal and then transferred by the capacitive isolation barrier. Across the isolation barrier, a differential comparator receives the logic transition information, and then sets or resets a flip-flop and the output circuit accordingly.

The AMC1203 is available in SOP-8 gull-wing, SOP-8, and SOIC-16 packages. The AMC1203 is characterized for operation over the ambient temperature range of –40°C to +105°C.

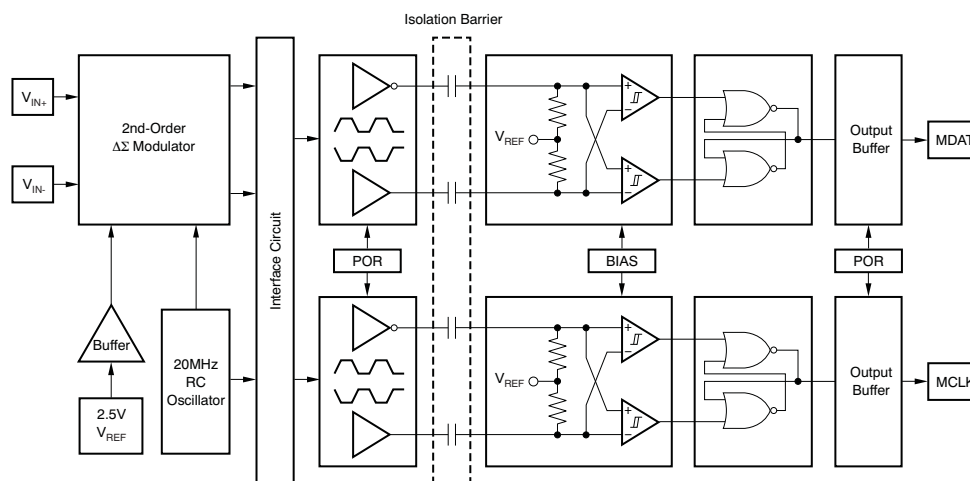

Please be aware that an important notice concerning availability, standard warranty, and use in critical applications of Texas Instruments semiconductor products and disclaimers thereto appears at the end of this data sheet.

All trademarks are the property of their respective owners.



This integrated circuit can be damaged by ESD. Texas Instruments recommends that all integrated circuits be handled with appropriate precautions. Failure to observe proper handling and installation procedures can cause damage.

ESD damage can range from subtle performance degradation to complete device failure. Precision integrated circuits may be more susceptible to damage because very small parametric changes could cause the device not to meet its published specifications.

PACKAGE/ORDERING INFORMATION⁽¹⁾

| PRODUCT | PACKAGE-LEAD | PACKAGE DESIGNATOR | SPECIFIED TEMPERATURE RANGE | PACKAGE MARKING | ORDERING NUMBER | TRANSPORT MEDIA, QUANTITY |
|----------|-----------------|--------------------|-----------------------------|-----------------|-----------------|---------------------------|
| AMC1203 | SOP-8 Gull-Wing | DUB | -40°C to +105°C | AMC1203 | AMC1203DUB | Tube, 50 |
| | | | | | AMC1203DUBR | Tape and Reel, 350 |
| | SOP-8 | PSA | -40°C to +105°C | 1203 | AMC1203PSA | Tube, 95 |
| | | | | | AMC1203PSAR | Tape and Reel, 2000 |
| | SOIC-16 | DW | -40°C to +105°C | AMC1203 | AMC1203DW | Tube, 40 |
| | | | | | AMC1203DWR | Tape and Reel, 2000 |
| AMC1203B | SOP-8 Gull-Wing | DUB | -40°C to +105°C | AMC1203 | AMC1203BDUB | Tube, 50 |
| | | | | | AMC1203BDUBR | Tape and Reel, 350 |
| | SOP-8 | PSA | -40°C to +105°C | 1203 | AMC1203BPSA | Tube, 95 |
| | | | | | AMC1203BPSAR | Tape and Reel, 2000 |
| | SOIC-16 | DW | -40°C to +105°C | AMC1203 | AMC1203BDW | Tube, 40 |
| | | | | | AMC1203BDWR | Tape and Reel, 2000 |

(1) For the most current package and ordering information see the Package Option Addendum at the end of this document, or visit the device product folder on www.ti.com.

ABSOLUTE MAXIMUM RATINGS⁽¹⁾

Over operating free-air temperature range, unless otherwise noted.

| PARAMETER | AMC1203 | UNIT |
|--|--|------------|
| Supply voltage, V_{DD1} to GND1 or V_{DD2} to GND2 | -0.3 to +6 | V |
| Analog input voltage at V_{IN+} , V_{IN-} | GND1 - 0.3 to $V_{DD1} + 0.3$ | V |
| Input current to any pin except supply pins | ±10 | mA |
| Continuous total power dissipation | See Dissipation Ratings Table | |
| Maximum junction temperature, T_J | +150 | °C |
| Electrostatic discharge (ESD), all pins | Human body model (HBM) JEDEC standard 22, test method A114-C.01 | ±3000 V |
| | Charged device Model (CDM) JEDEC standard 22, test method C101 | ±1500 V |
| | Machine Model (MM) JEDEC standard 22, test method A115A | ±200 V |

(1) Stresses beyond those listed under absolute maximum ratings may cause permanent damage to the device. These are stress ratings only, and functional operation of the device at these or any other conditions beyond those indicated under the [Recommended Operating Conditions](#) is not implied. Exposure to absolute maximum rated conditions for extended periods may affect device reliability.

THERMAL CHARACTERISTICS⁽¹⁾

Over recommended operating conditions, unless otherwise noted.

| PARAMETER | | SOP-8 GULL-WING | SOP-8 | SOIC-16 | UNIT | |
|---------------|-------------------------------------|-----------------|-------|---------|------|------|
| θ_{JA} | Junction-to-air thermal resistance | Low-K | 127 | 246 | 104 | °C/W |
| | | High-K | 78 | 164 | 58 | °C/W |
| θ_{JC} | Junction-to-case thermal resistance | 61 | 32 | 25 | °C/W | |
| P_D | Device power dissipation (max) | 110 | 110 | 110 | mW | |

(1) Tested in accordance with the Low-K or High-K thermal metric definitions of EIA/JESD51-3 for leaded surface mount packages.

RECOMMENDED OPERATING CONDITIONS

Over operating free-air temperature range, unless otherwise noted.

| PARAMETER | MIN | NOM | MAX | UNIT |
|---|------|-----|-----------|------|
| Supply voltage, V_{DD1} to GND1 or V_{DD2} to GND2 | 4.5 | 5.0 | 5.5 | V |
| Common-mode operating range, V_{CM} | 0 | | V_{DD1} | V |
| Differential input voltage, $(V_{IN+}) - (V_{IN-})$ | -280 | | 280 | mV |
| Operating junction temperature range, T_J (see the Thermal Characteristics table) | -40 | | +125 | °C |

DISSIPATION RATINGS⁽¹⁾

| PACKAGE | DERATING FACTOR ABOVE $T_A = +25^\circ\text{C}$ | $T_A \leq +25^\circ\text{C}$ POWER RATING | $T_A = +70^\circ\text{C}$ POWER RATING | $T_A = +85^\circ\text{C}$ POWER RATING | $T_A = +125^\circ\text{C}$ POWER RATING |
|-----------------|---|---|--|--|---|
| SOP-8 Gull-Wing | 7.9mW/°C | 984mW | 629mW | 511mW | 354mW |
| SOP-8 | 4.1mW/°C | 508mW | 325mW | 264mW | 182mW |
| SOIC-16 | 9.6mW/°C | 1201mW | 769mW | 625mW | 432mW |

(1) Based on Low-K thermal resistance.

REGULATORY INFORMATION

| VDE | UL |
|--------------------------------------|---|
| Certified according to IEC 60747-5-2 | Recognized under 1577 Component Recognition Program |
| File Number: 40014131 | File Number: E181974 |

IEC 60747-5-2 ISOLATION CHARACTERISTICS

Over recommended operating conditions, unless otherwise noted.

| PARAMETER | TEST CONDITIONS | VALUE | UNIT | |
|------------|------------------------------------|---|----------|----------|
| V_{IORM} | Maximum working insulation voltage | 560 | V | |
| V_{PD} | Input to output test voltage | Method A, after input or safety test (subgroup 2 or 3), $V_{PD} = V_{IORM} \times 1.2$, $t = 10\text{s}$, partial discharge < 5pC | 672 | V |
| | | Method A, after environmental test (subgroup 1), $V_{PD} = V_{IORM} \times 1.6$, $t = 10\text{s}$, partial discharge < 5pC | 896 | V |
| | | Method B1, routine and initial test, $V_{PD} = V_{IORM} \times 1.875$, 100% production test with $t = 1\text{s}$, partial discharge < 5pC | 1050 | V |
| V_{IOTM} | Transient overvoltage | $t = 60\text{s}$ | 4000 | V |
| R_S | Isolation resistance | $V_{IO} = 500\text{V}$ at T_S | $> 10^9$ | Ω |
| PD | Pollution degree | | 2 | |

PACKAGE CHARACTERISTICS⁽¹⁾

Over recommended operating conditions, unless otherwise noted.

| PARAMETER | | TEST CONDITIONS | MIN | TYP | MAX | UNIT |
|-----------------|--|--|--------------------|-----|-----|------|
| L(I01) | Minimum air gap (clearance) | Shortest terminal to terminal distance through air | DUB | 7 | | mm |
| | | | DW | 8 | | mm |
| | | | PSA | 6.3 | | mm |
| L(I02) | Minimum external tracking (creepage) | Shortest terminal to terminal distance across the package surface | DUB | 7 | | mm |
| | | | DW | 8 | | mm |
| | | | PSA | 6.3 | | mm |
| CTI | Tracking resistance (comparative tracking index) | DIN IEC 60112 / VDE 0303 Part 1 | ≥ 175 | | | V |
| | Minimum internal gap (internal clearance) | Distance through the insulation | 0.008 | | | mm |
| R _{IO} | Isolation resistance | Input to output, V _{IO} = 500V, all pins on each side of the barrier tied together creating a two-terminal device, T _A < +85°C | > 10 ¹² | | | Ω |
| | | Input to output, V _{IO} = 500V, +100°C ≤ T _A < T _A max | > 10 ¹¹ | | | Ω |
| C _{IO} | Barrier capacitance input to output | V _I = 0.8V _{PP} at 1MHz | | 1.2 | | pF |
| C _I | Input capacitance to ground | V _I = 0.8V _{PP} at 1MHz | | 3 | | pF |

- (1) Creepage and clearance requirements should be applied according to the specific equipment isolation standards of an application. Care should be taken to maintain the creepage and clearance distance of the board design to ensure that the mounting pads of the isolator on the printed circuit board do not reduce this distance. Creepage and clearance on a printed circuit board become equal according to the measurement techniques shown in the [Isolation Glossary](#). Techniques such as inserting grooves and/or ribs on a printed circuit board are used to help increase these specifications.

IEC SAFETY LIMITING VALUES

Safety limiting intends to prevent potential damage to the isolation barrier upon failure of input or output (I/O) circuitry. A failure of the I/O circuitry can allow low resistance to ground or the supply and, without current limiting, dissipate sufficient power to overheat the die and damage the isolation barrier, potentially leading to secondary system failures.

The safety-limiting constraint is the operating virtual junction temperature range specified in the [Absolute Maximum Ratings](#) table. The power dissipation and junction-to-air thermal impedance of the device installed in the application hardware determines the junction temperature. The assumed junction-to-air thermal resistance in the [Thermal Characteristics](#) table is that of a device installed in the JESD51-3, *Low Effective Thermal Conductivity Test Board for Leaded Surface Mount Packages* and is conservative. The power is the recommended maximum input voltage times the current. The junction temperature is then the ambient temperature plus the power times the junction-to-air thermal resistance.

| PARAMETER | | TEST CONDITIONS | MIN | TYP | MAX | UNIT |
|----------------|---|---|-----|-----|------|------|
| I _S | Safety input, output, or supply current | θ _{JA} = 246°C/W, V _I = 5.5V, T _J = +150°C, T _A = +25°C | | | 90 | mA |
| T _C | Maximum case temperature | | | | +150 | °C |

IEC 61000-4-5 RATINGS

| PARAMETER | | TEST CONDITIONS | VALUE | UNIT |
|-------------------|----------------|---|-------|------|
| V _{IOSM} | Surge immunity | 1.2/50μs voltage surge and 8/20μs current surge | ±6000 | V |

IEC 60664-1 RATINGS

| PARAMETER | TEST CONDITIONS | SPECIFICATION |
|-----------------------------|--|---------------|
| Basic isolation group | Material group | IIIa |
| Installation classification | Rated mains voltage ≤ 150 V _{RMS} | I-IV |
| | Rated mains voltage < 300 V _{RMS} | I-III |

ELECTRICAL CHARACTERISTICS

At $T_A = -40^\circ\text{C}$ to $+105^\circ\text{C}$, $V_{DD1} = 4.5\text{V}$ to 5.5V , $V_{DD2} = 4.5\text{V}$ to 5.5V , $V_{IN+} = -280\text{mV}$ to $+280\text{mV}$, $V_{IN-} = 0\text{V}$, and sinc³ filter with OSR = 256, unless otherwise noted.

| PARAMETER | | TEST CONDITIONS | AMC1203 | | | UNIT |
|-----------------------|---|----------------------------------|-------------------|--------------------|-------------------|--------|
| | | | MIN | TYP ⁽¹⁾ | MAX | |
| RESOLUTION | | | 16 | | | Bits |
| DC ACCURACY | | | | | | |
| INL | Integral linearity error ⁽²⁾ | AMC1203 | | ±3 | ±9 | LSB |
| | | AMC1203B | | ±2 | ±6 | LSB |
| DNL | Differential nonlinearity ⁽³⁾ | | -1 | | +1 | LSB |
| V_{OS} | Offset error ⁽⁴⁾ | | -1 | ±0.1 | 1 | mV |
| TCV_{OS} | Offset error thermal drift | | | ±1.5 | ±5 | µV/°C |
| G_{ERR} | Gain error | AMC1203 | -2 | ±0.2 | 2 | % |
| | | AMC1203B | -1 | ±0.2 | 1 | % |
| TCG_{ERR} | Gain error thermal drift | | | ±20 | | ppm/°C |
| PSRR | Power-supply rejection ratio | | | 80 | | dB |
| ANALOG INPUTS | | | | | | |
| FSR | Full-scale differential voltage input range | $(V_{IN+}) - (V_{IN-})$ | -320 | | 320 | mV |
| V_{CM} | Operating common-mode signal ⁽³⁾ | | -0.1 | | 5 | V |
| C_I | Input capacitance to GND1 | V_{IN+} or V_{IN-} | | 3 | | pF |
| C_{ID} | Differential input capacitance | | | 6 | | pF |
| R_{ID} | Differential input resistance | | | 28 | | kΩ |
| I_{IL} | Input leakage current | | -5 | | 5 | nA |
| CMTI | Common-mode transient immunity | $V_{CM} = 1\text{kV}$ | 15 | | | kV/µs |
| CMRR | Common-mode rejection ratio | V_{IN} from 0V to 5V at 0Hz | | 92 | | dB |
| | | V_{IN} from 0V to 5V at 50kHz | | 105 | | dB |
| INTERNAL CLOCK | | | | | | |
| t_{CLK} | Clock period | See Figure 2 | 83.33 | 100 | 125 | ns |
| f_{CLK} | Clock frequency | See Figure 2 | 8 | 10 | 12 | MHz |
| t_H | Clock high-time | See Figure 2 | $(t_{CLK}/2) - 8$ | 50 | $(t_{CLK}/2) + 8$ | ns |
| t_{D1} | Data valid time after falling edge of clock | See Figure 2 | -2 | 0 | 2 | ns |
| AC ACCURACY | | | | | | |
| SINAD | Signal-to-noise + distortion | $f_{IN} = 1\text{kHz}$ | 80 | 85 | | dB |
| SNR | Signal-to-noise ratio | $f_{IN} = 1\text{kHz}$ | 80.5 | 85 | | dB |
| THD | Total harmonic distortion | AMC1203, $f_{IN} = 1\text{kHz}$ | | -92 | -84.5 | dB |
| | | AMC1203B, $f_{IN} = 1\text{kHz}$ | | -95 | -88 | |
| SFDR | Spurious-free dynamic range | AMC1203, $f_{IN} = 1\text{kHz}$ | 86 | 92 | | dB |
| | | AMC1203B, $f_{IN} = 1\text{kHz}$ | 89 | 95 | | |

(1) All typical values are at $T_A = +25^\circ\text{C}$

(2) Integral nonlinearity is defined as the maximum deviation of the line through the inputs of the specified input range of the transfer curve of the specified V_{IN} expressed either as number of LSBs, or as a percent of the specified 560mV input range.

(3) Ensured by design.

(4) Maximum values, including temperature drift, are ensured over the full specified temperature range.

ELECTRICAL CHARACTERISTICS (continued)

At $T_A = -40^\circ\text{C}$ to $+105^\circ\text{C}$, $V_{DD1} = 4.5\text{V}$ to 5.5V , $V_{DD2} = 4.5\text{V}$ to 5.5V , $V_{IN+} = -280\text{mV}$ to $+280\text{mV}$, $V_{IN-} = 0\text{V}$, and sinc³ filter with OSR = 256, unless otherwise noted.

| PARAMETER | TEST CONDITIONS | AMC1203 | | | UNIT | |
|------------------------|---------------------------|-------------------------|--------------------|-----|------|----|
| | | MIN | TYP ⁽¹⁾ | MAX | | |
| DIGITAL OUTPUTS | | | | | | |
| V_{OH} | High-level output voltage | $I_{OH} = -8\text{mA}$ | $V_{DD2} - 0.8$ | 4.6 | V | |
| | | $I_{OH} = -4\text{mA}$ | $V_{DD2} - 0.4$ | 4.8 | V | |
| V_{OL} | Low-level output voltage | $I_{OL} = 8\text{mA}$ | | 0.3 | 0.8 | V |
| | | $I_{OL} = 4\text{mA}$ | | 0.2 | 0.4 | V |
| POWER SUPPLY | | | | | | |
| V_{DD} | Supply voltage | V_{DD1} and V_{DD2} | 4.5 | 5.0 | 5.5 | V |
| I_{DD1} | Analog supply current | | | 6 | 8 | mA |
| I_{DD2} | Digital supply current | | | 10 | 12 | mA |
| P_D | Power dissipation | | | 80 | 110 | mW |

EQUIVALENT INPUT CIRCUIT

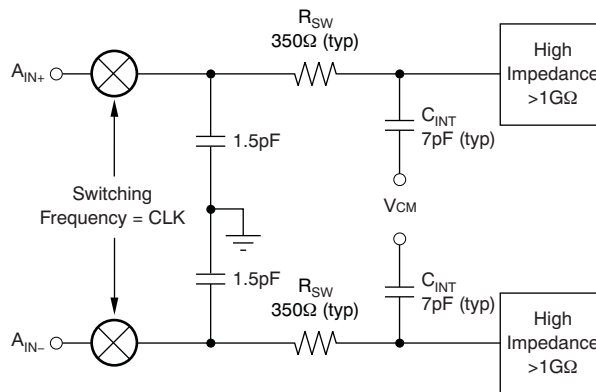

Figure 1. Equivalent Analog Input Circuit

PIN CONFIGURATION

**DUB or PSA PACKAGE
SOP-8 Gull-Wing or SOP-8
(TOP VIEW)**

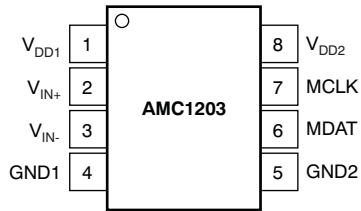

Table 1. SOP-8 PIN DESCRIPTIONS

| PIN | | DESCRIPTION |
|-----|------------------|---------------------------|
| NO. | NAME | |
| 1 | V _{DD1} | Analog power supply |
| 2 | V _{IN+} | Noninverting analog input |
| 3 | V _{IN-} | Inverting analog input |
| 4 | GND1 | Analog ground |
| 5 | GND2 | Digital ground |
| 6 | MDAT | Modulator data output |
| 7 | MCLK | Modulator clock output |
| 8 | V _{DD2} | Digital power supply |

**DW PACKAGE
SOIC-16
(TOP VIEW)**

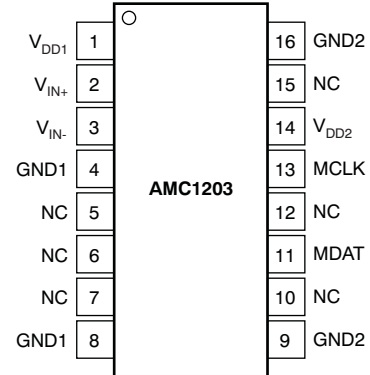

Table 2. SOIC-16 PIN DESCRIPTIONS

| PIN | | DESCRIPTION |
|----------------------|------------------|---|
| NO. | NAME | |
| 1 | V _{DD1} | Analog power supply |
| 2 | V _{IN+} | Noninverting analog input |
| 3 | V _{IN-} | Inverting analog input |
| 4, 8 ⁽¹⁾ | GND1 | Analog ground |
| 5, 6, 7, 10, 12, 15 | NC | No internal connection—can be tied to any potential or left unconnected |
| 9, 16 ⁽¹⁾ | GND2 | Digital ground |
| 11 | MDAT | Modulator data output |
| 13 | MCLK | Modulator clock output |
| 14 | V _{DD2} | Digital power supply |

- (1) Both pins are connected internally via a low-impedance path; thus only one of the pins must be tied to the ground plane.

TIMING INFORMATION

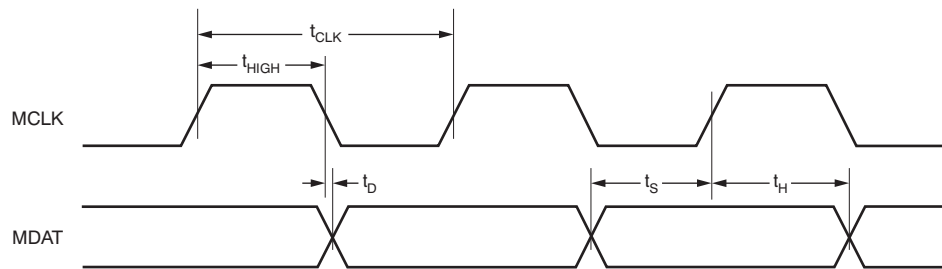

Figure 2. Modulator Output Mode Timing

TIMING CHARACTERISTICS FOR MODULATOR OUTPUT MODE

Over recommended operating free-air temperature range at -40°C to $+105^{\circ}\text{C}$, $V_{\text{DD1}} = +5\text{V}$, and $V_{\text{DD2}} = +5\text{V}$, unless otherwise noted.

| PARAMETER | | MIN | TYP | MAX | UNIT |
|-------------------|--|--------------------------|---------|--------------------------|------|
| t_{CLK} | MCLK clock period | 83.33 | 100 | 125 | ns |
| t_{HIGH} | MCLK clock high time | $(t_{\text{CLK}}/2) - 8$ | $t_p/2$ | $(t_{\text{CLK}}/2) + 8$ | ns |
| t_{D} | Data delay after falling edge of MCLK | -2 | 0 | 2 | ns |
| t_{S} | Data setup time prior to rising edge of MCLK | 31.5 | | | ns |
| t_{H} | Data hold time after rising edge of MCLK | 31.5 | | | ns |

TYPICAL CHARACTERISTICS

At $V_{DD1} = V_{DD2} = 5V$, $V_{IN+} = -280mV$ to $+280mV$, $V_{IN-} = 0V$, and sinc³ filter with OSR = 256, unless otherwise noted.

**INTEGRAL NONLINEARITY
vs INPUT SIGNAL AMPLITUDE**

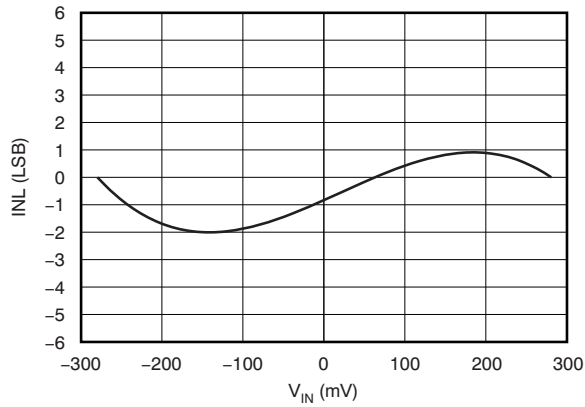

Figure 3.

**INTEGRAL NONLINEARITY
vs TEMPERATURE**

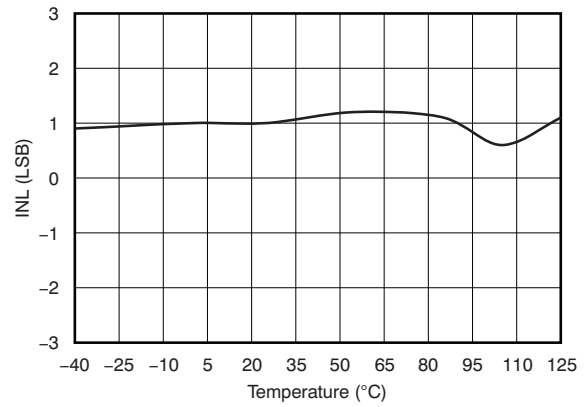

Figure 4.

**OFFSET ERROR
vs SUPPLY VOLTAGE**

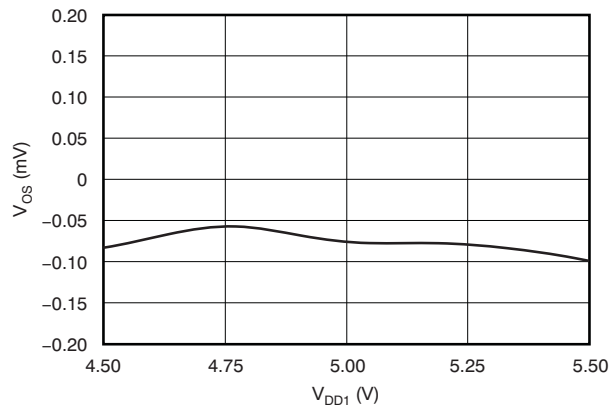

Figure 5.

**OFFSET ERROR
vs TEMPERATURE**

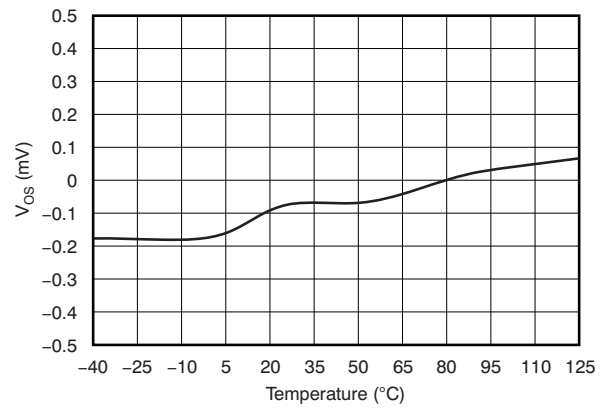

Figure 6.

**GAIN ERROR
vs TEMPERATURE**

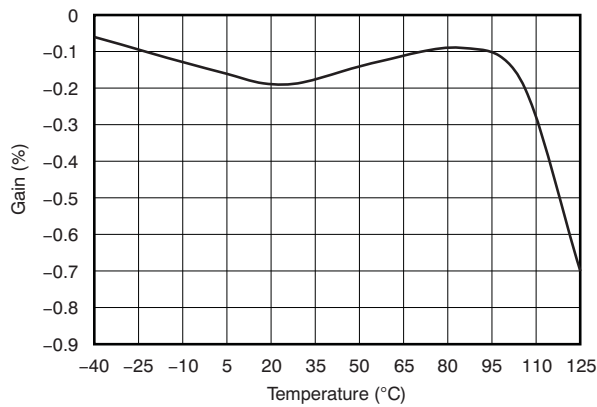

Figure 7.

**EFFECTIVE NUMBER OF BITS
vs OVERSAMPLING RATIO**

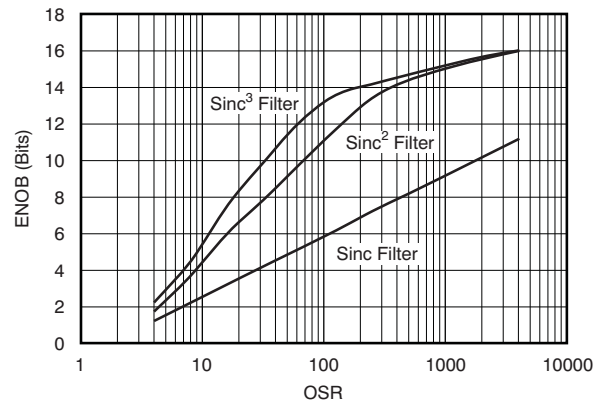

Figure 8.

TYPICAL CHARACTERISTICS (continued)

At $V_{DD1} = V_{DD2} = 5V$, $V_{IN+} = -280mV$ to $+280mV$, $V_{IN-} = 0V$, and sinc³ filter with OSR = 256, unless otherwise noted.

**SIGNAL-TO-NOISE RATIO
vs INPUT SIGNAL AMPLITUDE**

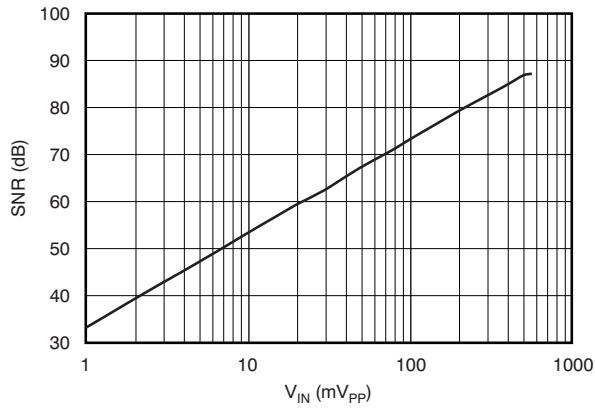

Figure 9.

**SIGNAL-TO-NOISE RATIO
vs TEMPERATURE**

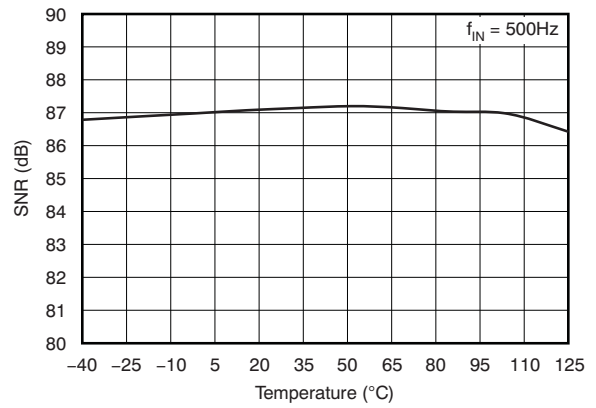

Figure 10.

**SIGNAL-TO-NOISE RATIO
vs INPUT SIGNAL FREQUENCY**

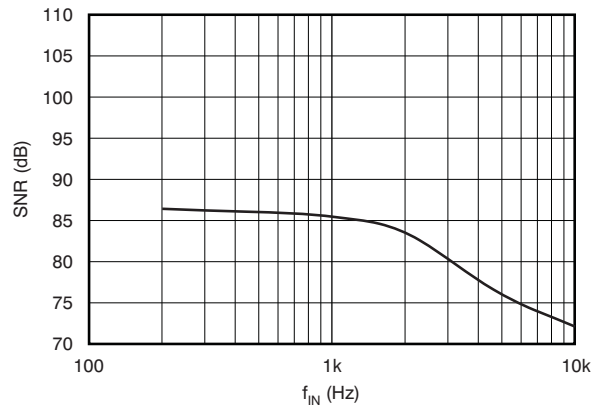

Figure 11.

**SIGNAL-TO-NOISE RATIO
vs TEMPERATURE**

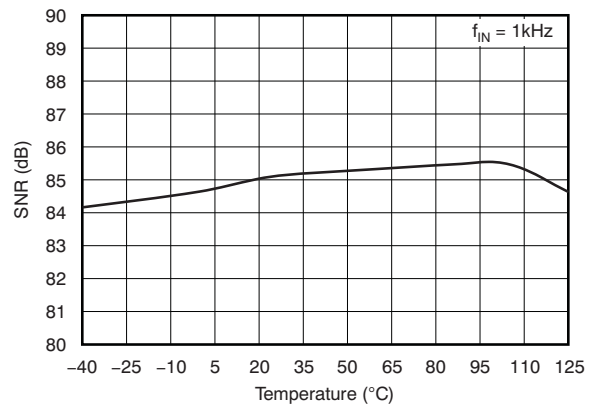

Figure 12.

**TOTAL HARMONIC DISTORTION
vs INPUT SIGNAL FREQUENCY**

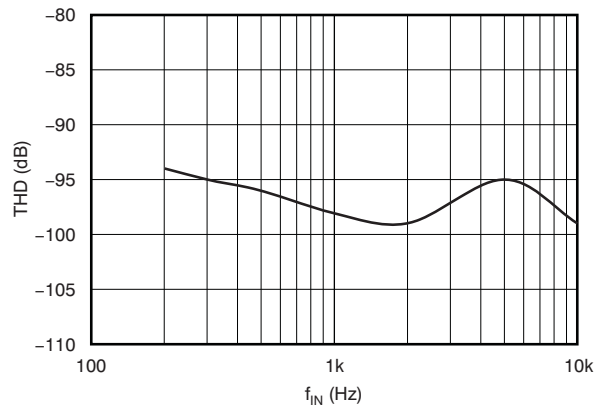

Figure 13.

**TOTAL HARMONIC DISTORTION
vs TEMPERATURE**

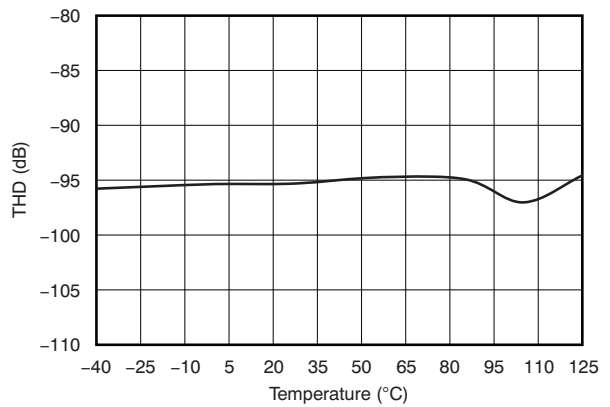

Figure 14.

TYPICAL CHARACTERISTICS (continued)

At $V_{DD1} = V_{DD2} = 5V$, $V_{IN+} = -280mV$ to $+280mV$, $V_{IN-} = 0V$, and sinc³ filter with OSR = 256, unless otherwise noted.

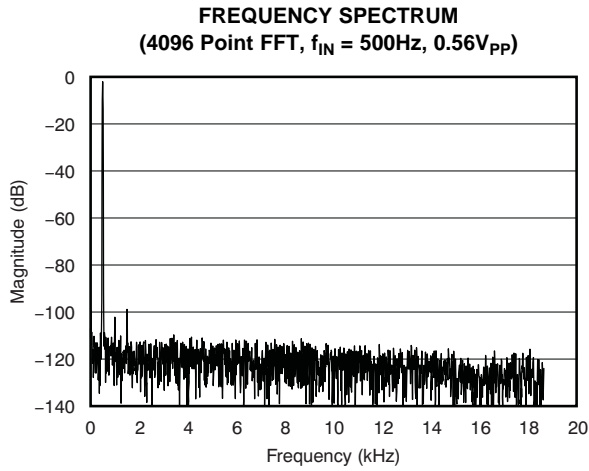

Figure 15.

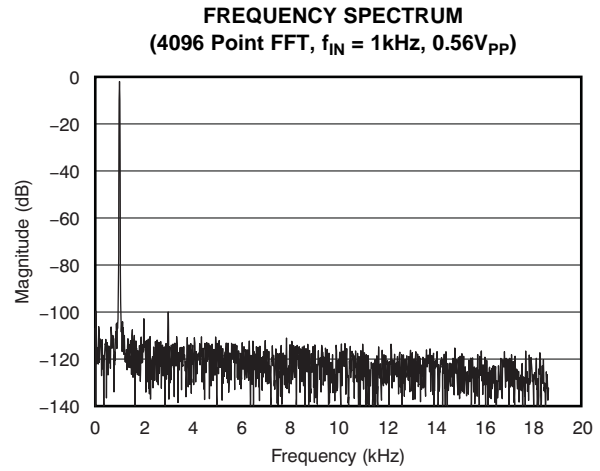

Figure 16.

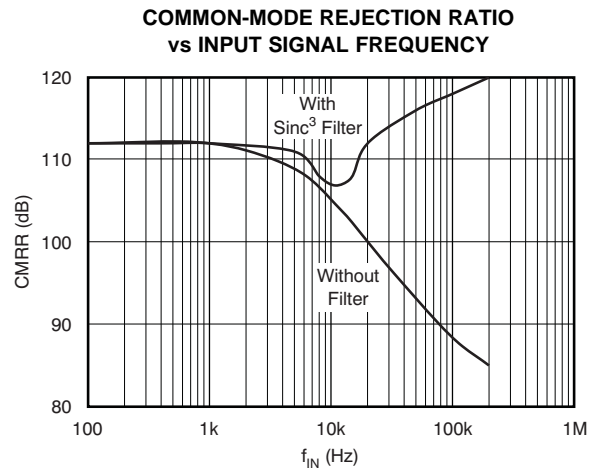

Figure 17.

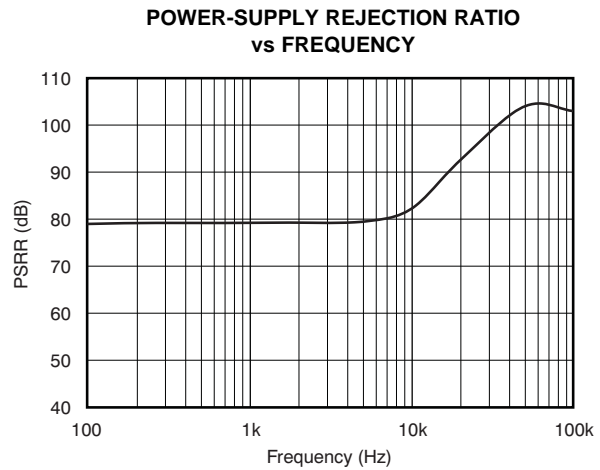

Figure 18.

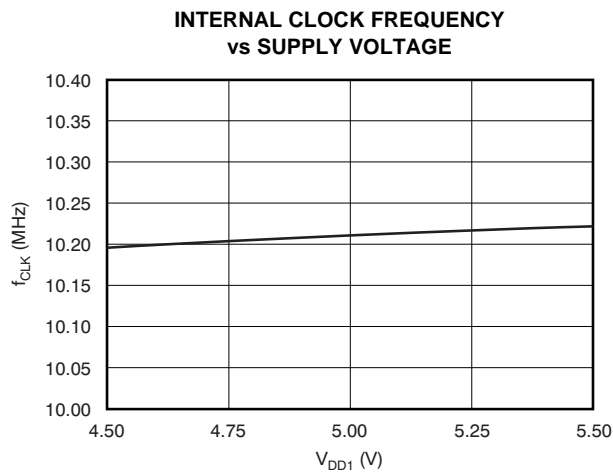

Figure 19.

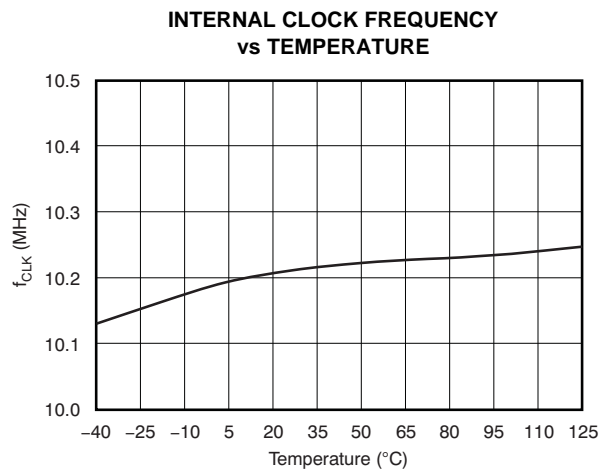

Figure 20.

TYPICAL CHARACTERISTICS (continued)

At $V_{DD1} = V_{DD2} = 5V$, $V_{IN+} = -280mV$ to $+280mV$, $V_{IN-} = 0V$, and sinc³ filter with OSR = 256, unless otherwise noted.

**ANALOG SUPPLY CURRENT
vs TEMPERATURE**

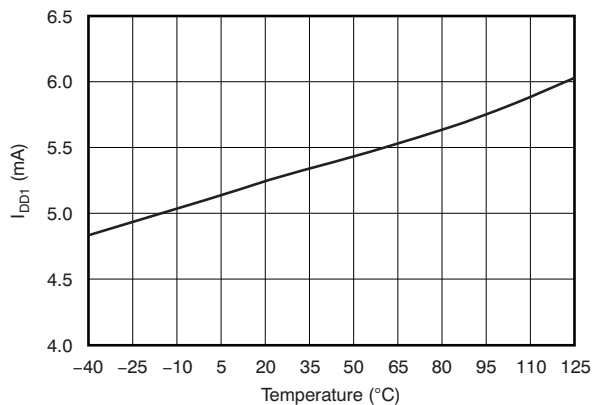

Figure 21.

**DIGITAL SUPPLY CURRENT
vs TEMPERATURE**

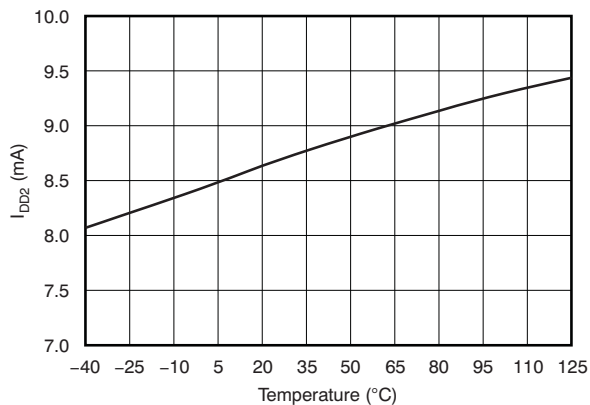

Figure 22.

GENERAL DESCRIPTION

The AMC1203 is a single-channel, 2nd-order, CMOS, delta-sigma modulator, designed for medium- to high-resolution A/D conversions from dc to 39kHz with an oversampling ratio (OSR) of 256. The isolated output of the converter (MDAT) provides a stream of digital ones and zeros. The time average of this serial output is proportional to the analog input voltage.

The modulator shifts the quantization noise to high frequencies; therefore, a low-pass digital filter should be used at the output of the device to increase the overall performance. This filter is also used to convert from the 1-bit data stream at a high sampling rate into a higher-bit data word at a lower rate (decimation). A digital signal processor (DSP), microcontroller (μC) or field programmable gate array (FPGA) can be used to implement the filter. Another option is using a

suitable application-specific device, such as the AMC1210, a four-channel digital sinc-filter. Figure 23 shows two AMC1203s and one ADS1205 (dual-channel, non-isolated modulator) connected to an AMC1210, building the entire analog front-end of a resolver-based motor-control application. For detailed information on the ADS1205 and AMC1210, please visit our home page at www.ti.com.

The overall performance (speed and accuracy) depends on the selection of an appropriate OSR and filter type. A higher OSR results in higher accuracy while operating at lower refresh rate. Alternatively, a lower OSR results in lower accuracy, but provides data at a higher refresh rate. This system allows flexibility with the digital filter design and is capable of A/D conversion results that have a dynamic range exceeding 95dB with OSR = 256.

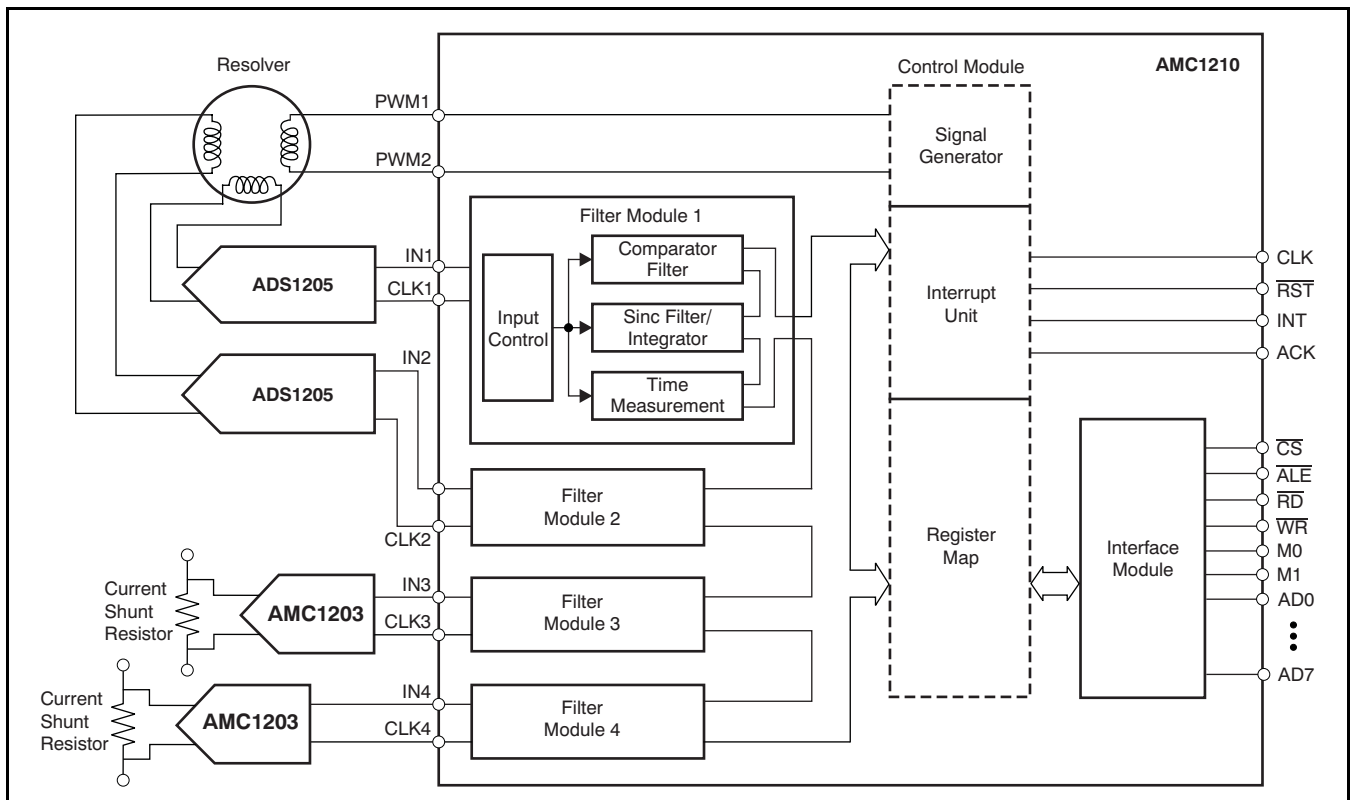

Figure 23. Example of a Resolver-Based Motor-Control Application

THEORY OF OPERATION

The differential analog input of the AMC1203 is implemented with a switched-capacitor circuit. This switched-capacitor circuit implements a 2nd-order modulator stage that digitizes the input signal into a 1-bit output stream. The internally-generated clock signal (sourcing the capacitor circuit and the modulator) is available as an output signal on the MCLK pin. The analog input signal is continuously sampled by the modulator and compared to an internal voltage reference. A digital stream, accurately representing the analog input voltage over time, appears at the output of the converter.

ANALOG INPUT

The input design topology of the AMC1203 is based on a fully-differential, switched-capacitor architecture with a dynamic input impedance of 28k Ω at 10MHz, as [Figure 1](#) shows. This input stage provides the mechanism to achieve low system noise, high common-mode rejection (92dB), and excellent power-supply rejection.

The input impedance becomes a consideration in designs with high input-signal source impedance. This high-impedance may cause degradation in gain, linearity, and THD. The importance of this effect, however, depends on the desired system performance.

There are two restrictions on the analog input signals, V_{IN+} and V_{IN-} . If the input voltage exceeds the range $GND - 0.3V$ to $V_{DD} + 0.3V$, the input current must be limited to 10mA, because the input protection diodes on the front end of the converter begin to turn on. In addition, the linearity and the noise performance of the device is ensured only when the differential analog voltage resides within $\pm 280mV$.

MODULATOR

The modulator topology of the AMC1203 is fundamentally a 2nd-order, switched-capacitor, delta-sigma modulator, such as the one conceptualized in [Figure 24](#). The analog input voltage ($X_{(t)}$) and the output of the 1-bit digital-to-analog converter (DAC) are differentiated, providing an analog voltage (X_2) at the input of the first integrator or modulator stage. The output of the first integrator is further differentiated with the DAC output, and the resulting voltage (X_3) feeds the input of the second integrator stage. When the value of the integrated signal (X_4) at the output of the second stage equals the comparator reference voltage, the output of the comparator switches from high to low, or vice versa, depending on its previous state. In this case, the 1-bit DAC responds on the next clock pulse by changing its analog output voltage (X_6), causing the integrators to progress in the opposite direction, while forcing the value of the integrator output to track the average of the input.

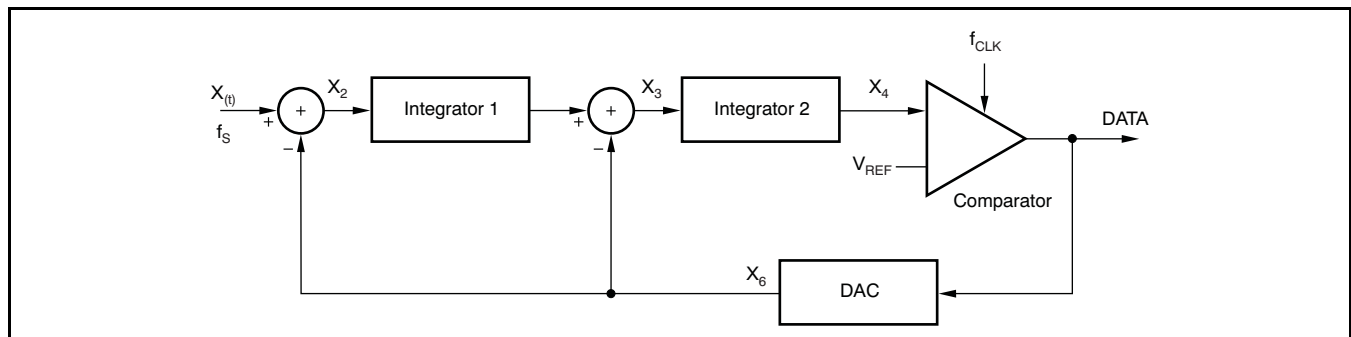

Figure 24. Block Diagram of the 2nd-Order Modulator

DIGITAL OUTPUT

A differential input signal of 0V ideally produces a stream of ones and zeros that are high 50% of the time and low 50% of the time. A differential input of +280mV produces a stream of ones and zeros that are high 87.5% of the time. A differential input of –280mV produces a stream of ones and zeros that are high 12.5% of the time. The input voltage versus the output modulator signal is shown in Figure 27.

The system clock of the AMC1203 is 20 MHz by default, and is generated internally using an RC circuit. The system clock is divided by two for the modulator clock; thus, the default clock frequency of the modulator is 10MHz. This clock is also available on the output terminal MCLK, whereas the data are provided at the MDAT output pin. The data are changing at the falling edge of MCLK, so data can safely be latched with the rising edge; see the Timing Characteristics.

FILTER USAGE

The modulator generates a bit stream that is processed by a digital filter to get a digital word similar to the conversion result of a conventional analog-to-digital converter (ADC). A very simple filter, built with minimal effort and hardware, is a sinc³ filter:

$$H(z) = \left(\frac{1 - z^{-OSR}}{1 - z^{-1}} \right)^3 \quad (1)$$

This filter provides the best output performance at the lowest hardware size (count of digital gates). For an OSR in the range of 16 to 256, this filter is a good choice. All the characterizations in this document are also done with a sinc³ filter with OSR=256 and an output word width of 16 bits.

In a sinc³ filter response (shown in Figure 25 and Figure 26), the location of the first notch occurs at the frequency of output data rate $f_{DATA} = f_{CLK}/OSR$. The –3dB point is located at half the Nyquist frequency or $f_{DATA}/4$.

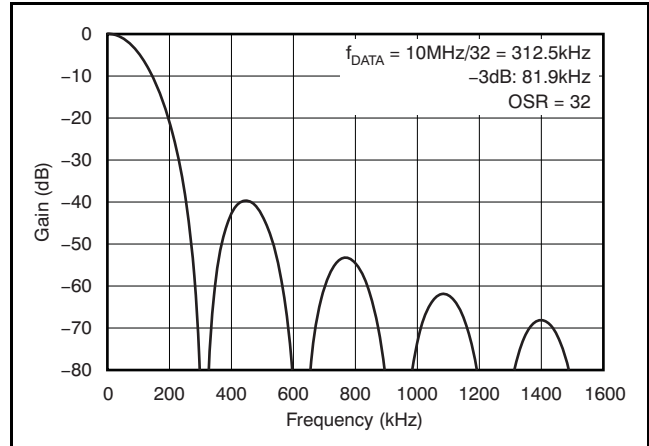

Figure 25. Frequency Response of the Sinc³ Filter

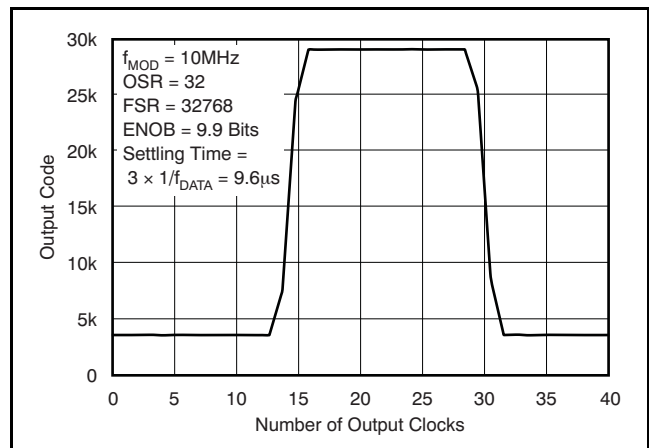

Figure 26. Pole Response of the Sinc³ Filter

Performance can be improved, for example, by using a cascaded filter structure. The first decimation stage could be built using a sinc³ filter with a low OSR and the second stage using a high-order filter.

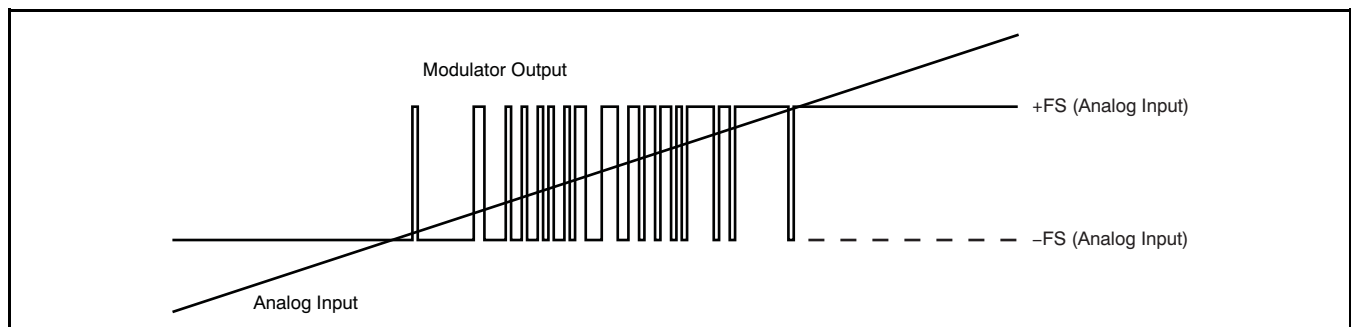

Figure 27. Analog Input vs Modulator Output

The effective number of bits (ENOB) is often used to compare the performance of ADCs and delta-sigma modulators. Figure 28 shows the ENOB of the AMC1203 with different oversampling ratios. In this data sheet, this number is calculated from the SNR using following formula:

$$\text{SNR} = 1.76\text{dB} + 6.02\text{dB} \times \text{ENOB} \tag{2}$$

In motor-control applications, a very fast response time for the over-current detection is required. The time for full settling of the filter depends on its order (that is, a sinc³ filter requires three data clocks for full settling (with $f_{\text{DATA}} = f_{\text{MOD}}/\text{OSR}$). Therefore, for over-current protection, filter types other than sinc³ might be a better choice; an alternative is the sinc² filter. Figure 29 compares the settling times of different filter orders (sincfast is a modified sinc² filter):

$$H(z) = \left(\frac{1 - z^{-\text{OSR}}}{1 - z^{-1}} \right)^2 (1 + z^{-2\text{OSR}}) \tag{3}$$

For more information, see application note SBAA094, *Combining the ADS1202 with an FPGA Digital Filter for Current Measurement in Motor Control Applications*, available for download at www.ti.com.

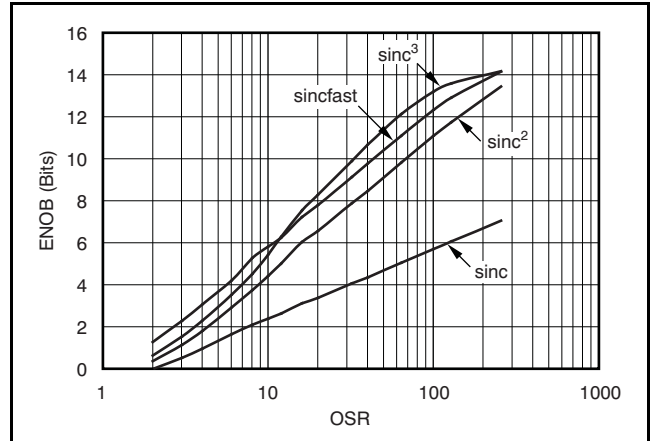

Figure 28. Measured Effective Number of Bits vs Oversampling Ratio

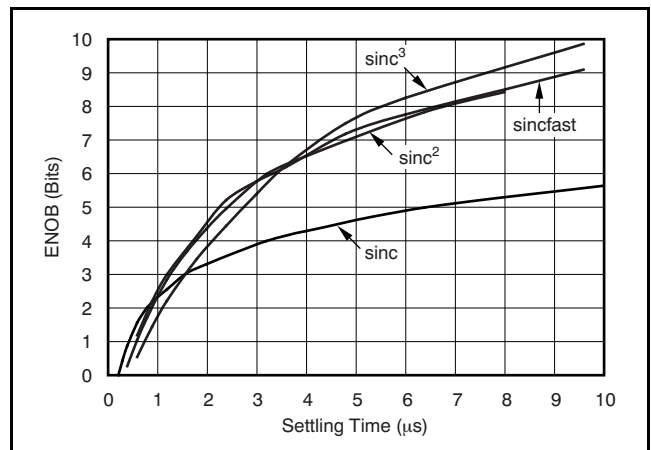

Figure 29. Measured Effective Number of Bits vs Settling Time

APPLICATION INFORMATION

A typical operation of the AMC1203 in a motor-control application is shown in Figure 30. Measurement of the motor phase current is done via the shunt resistor R_{SHUNT} ; in this case, a 2-terminal shunt). For better performance, the differential signal is filtered using RC filters (components R_2 , R_3 and C_2). Optionally, C_3 and C_4 can be used to reduce charge dumping from the inputs. In this case, care should be taken when choosing the quality of these capacitors—mismatch in values of these capacitors will lead to a common-mode error at the input of the modulator.

The high-side power supply for the AMC1203 (V_{DD1}) is derived from the power supply of the upper gate driver. For lowest cost, a Zener diode can be used to limit the voltage to $5V \pm 10\%$. A decoupling capacitor

of $0.1\mu F$ is recommended for filtering this power-supply path. This capacitor C_1 in Figure 30) should be placed as close as possible to the V_{DD1} pin for best performance. If better filtering is required, an additional $1\mu F$ to $10\mu F$ capacitor can be used. The floating ground reference (GND1) is derived from the end of the shunt resistor, which is connected to the negative input of the AMC1203 (V_{IN-}). If a 4-terminal shunt is used, the inputs of the AMC1203 are connected to the inner leads, while GND1 is connected to one of the outer leads of the shunt. Both digital outputs, MCLK and MDAT, can be directly connected to a digital filter (that is, the AMC1210); see Figure 23.

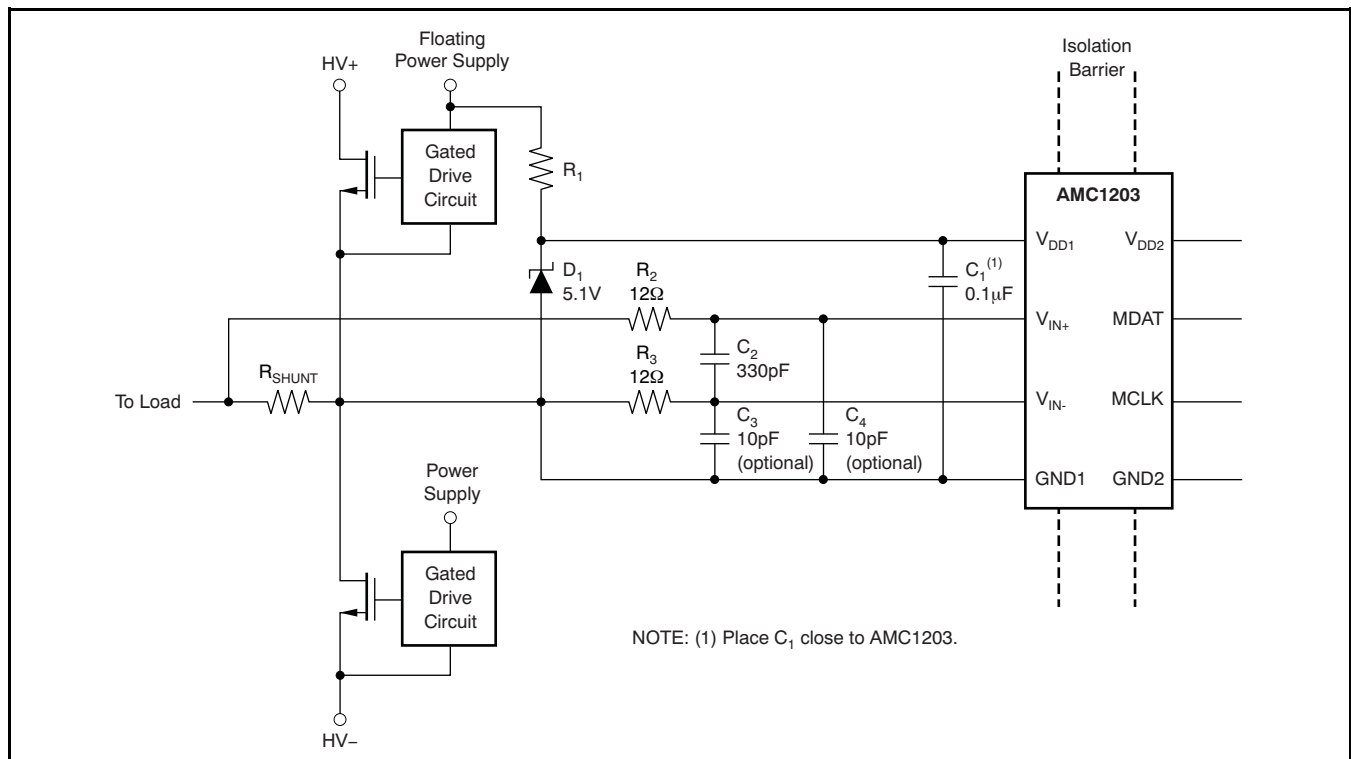
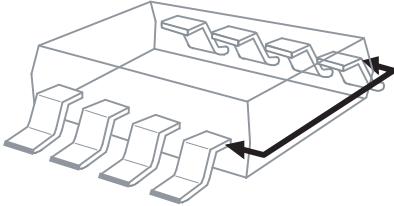

Figure 30. Typical Application Diagram

ISOLATION GLOSSARY

Creepage Distance: The shortest path between two conductive input to output leads measured along the surface of the insulation. The shortest distance path is found around the end of the package body.



Clearance: The shortest distance between two conductive input to output leads measured through air (line of sight).

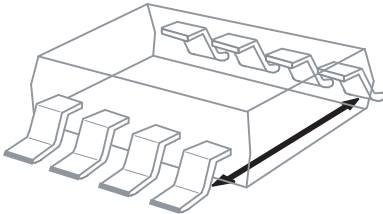

Input-to Output Barrier Capacitance: The total capacitance between all input terminals connected together, and all output terminals connected together.

Input-to Output Barrier Resistance: The total resistance between all input terminals connected together, and all output terminals connected together.

Primary Circuit: An internal circuit directly connected to an external supply mains or other equivalent source that supplies the primary circuit electric power.

Secondary Circuit: A circuit with no direct connection to primary power that derives its power from a separate isolated source.

Comparative Tracking Index (CTI): CTI is an index used for electrical insulating materials. It is defined as the numerical value of the voltage that causes failure by tracking during standard testing. Tracking is the process that produces a partially conducting path of localized deterioration on or through the surface of an insulating material as a result of the action of electric discharges on or close to an insulation surface. The higher CTI value of the insulating material, the smaller the minimum creepage distance.

Generally, insulation breakdown occurs either through the material, over its surface, or both. Surface failure may arise from flashover or from the progressive degradation of the insulation surface by small localized sparks. Such sparks are the result of the breaking of a surface film of conducting contaminant on the insulation. The resulting break in

the leakage current produces an overvoltage at the site of the discontinuity, and an electric spark is generated. These sparks often cause carbonization on insulation material and lead to a carbon track between points of different potential. This process is known as *tracking*.

Insulation:

Operational insulation—Insulation needed for the correct operation of the equipment.

Basic insulation—Insulation to provide basic protection against electric shock.

Supplementary insulation—Independent insulation applied in addition to basic insulation in order to ensure protection against electric shock in the event of a failure of the basic insulation.

Double insulation—Insulation comprising both basic and supplementary insulation.

Reinforced insulation—A single insulation system that provides a degree of protection against electric shock equivalent to double insulation.

Pollution Degree:

Pollution Degree 1—No pollution, or only dry, nonconductive pollution occurs. The pollution has no influence on device performance.

Pollution Degree 2—Normally, only nonconductive pollution occurs. However, a temporary conductivity caused by condensation is to be expected.

Pollution Degree 3—Conductive pollution, or dry nonconductive pollution that becomes conductive because of condensation, occurs. Condensation is to be expected.

Pollution Degree 4—Continuous conductivity occurs as a result of conductive dust, rain, or other wet conditions.

Installation Category:

Overvoltage Category—This section is directed at insulation coordination by identifying the transient overvoltages that may occur, and by assigning four different levels as indicated in IEC 60664.

I: Signal Level: Special equipment or parts of equipment.

II: Local Level: Portable equipment, etc.

III: Distribution Level: Fixed installation.

IV: Primary Supply Level: Overhead lines, cable systems.

Each category should be subject to smaller transients than the previous category.

REVISION HISTORY

NOTE: Page numbers for previous revisions may differ from page numbers in the current version.

| Changes from Revision B (May 2010) to Revision C | Page |
|--|-------------|
| • Changed text in Features bullet from "Operating" to "Specified" for temperature range | 1 |
| • Changed Minimum Air Gap parameter in Package Characteristics table to show values for all packages | 4 |
| • Added V_{IOSM} symbol to Surge Immunity parameter in IEC 61000-4-5 Ratings table | 4 |

| Changes from Revision A (March 2009) to Revision B | Page |
|--|-------------|
| • Deleted references to upcoming availability of SO-8 and SO-16 packages throughout document | 1 |
| • Renamed SO-8 to SOP-8 and SO-16 to SOIC-16 throughout document | 1 |

PACKAGING INFORMATION

| Orderable Device | Status (1) | Package Type | Package Drawing | Pins | Package Qty | Eco Plan (2) | Lead/Ball Finish (6) | MSL Peak Temp (3) | Op Temp (°C) | Device Marking (4/5) | Samples |
|------------------|---------------|--------------|-----------------|------|-------------|-------------------------|-------------------------|----------------------|--------------|-------------------------|-------------------------|
| AMC1203BDUB | ACTIVE | SOP | DUB | 8 | 50 | Green (RoHS & no Sb/Br) | CU NIPDAU | Level-3-260C-168 HR | -40 to 105 | AMC1203 B | Samples |
| AMC1203BDUBR | ACTIVE | SOP | DUB | 8 | 350 | Green (RoHS & no Sb/Br) | CU NIPDAU | Level-3-260C-168 HR | -40 to 105 | AMC1203 B | Samples |
| AMC1203BDW | ACTIVE | SOIC | DW | 16 | 40 | Green (RoHS & no Sb/Br) | CU NIPDAU | Level-3-260C-168 HR | -40 to 105 | AMC1203 B | Samples |
| AMC1203BDWR | ACTIVE | SOIC | DW | 16 | 2000 | Green (RoHS & no Sb/Br) | CU NIPDAU | Level-3-260C-168 HR | -40 to 105 | AMC1203 B | Samples |
| AMC1203BPSA | ACTIVE | SOP | PSA | 8 | 95 | Green (RoHS & no Sb/Br) | CU NIPDAU | Level-3-260C-168 HR | -40 to 105 | 1203 B | Samples |
| AMC1203BPSAR | ACTIVE | SOP | PSA | 8 | 2000 | Green (RoHS & no Sb/Br) | CU NIPDAU | Level-3-260C-168 HR | -40 to 105 | 1203 B | Samples |
| AMC1203DUB | ACTIVE | SOP | DUB | 8 | 50 | Green (RoHS & no Sb/Br) | CU NIPDAU | Level-3-260C-168 HR | -40 to 105 | AMC1203 | Samples |
| AMC1203DUBG4 | ACTIVE | SOP | DUB | 8 | 50 | Green (RoHS & no Sb/Br) | CU NIPDAU | Level-3-260C-168 HR | -40 to 105 | AMC1203 | Samples |
| AMC1203DUBR | ACTIVE | SOP | DUB | 8 | 350 | Green (RoHS & no Sb/Br) | CU NIPDAU | Level-3-260C-168 HR | -40 to 105 | AMC1203 | Samples |
| AMC1203DW | ACTIVE | SOIC | DW | 16 | 40 | Green (RoHS & no Sb/Br) | CU NIPDAU | Level-3-260C-168 HR | -40 to 105 | AMC1203 | Samples |
| AMC1203DWR | ACTIVE | SOIC | DW | 16 | 2000 | Green (RoHS & no Sb/Br) | CU NIPDAU | Level-3-260C-168 HR | -40 to 105 | AMC1203 | Samples |
| AMC1203PSA | ACTIVE | SOP | PSA | 8 | 95 | Green (RoHS & no Sb/Br) | CU NIPDAU | Level-3-260C-168 HR | -40 to 105 | 1203 | Samples |
| AMC1203PSAR | ACTIVE | SOP | PSA | 8 | 2000 | Green (RoHS & no Sb/Br) | CU NIPDAU | Level-3-260C-168 HR | -40 to 105 | 1203 | Samples |

(1) The marketing status values are defined as follows:

ACTIVE: Product device recommended for new designs.

LIFEBUY: TI has announced that the device will be discontinued, and a lifetime-buy period is in effect.

NRND: Not recommended for new designs. Device is in production to support existing customers, but TI does not recommend using this part in a new design.

PREVIEW: Device has been announced but is not in production. Samples may or may not be available.

OBSELETE: TI has discontinued the production of the device.

⁽²⁾ Eco Plan - The planned eco-friendly classification: Pb-Free (RoHS), Pb-Free (RoHS Exempt), or Green (RoHS & no Sb/Br) - please check <http://www.ti.com/productcontent> for the latest availability information and additional product content details.

TBD: The Pb-Free/Green conversion plan has not been defined.

Pb-Free (RoHS): TI's terms "Lead-Free" or "Pb-Free" mean semiconductor products that are compatible with the current RoHS requirements for all 6 substances, including the requirement that lead not exceed 0.1% by weight in homogeneous materials. Where designed to be soldered at high temperatures, TI Pb-Free products are suitable for use in specified lead-free processes.

Pb-Free (RoHS Exempt): This component has a RoHS exemption for either 1) lead-based flip-chip solder bumps used between the die and package, or 2) lead-based die adhesive used between the die and leadframe. The component is otherwise considered Pb-Free (RoHS compatible) as defined above.

Green (RoHS & no Sb/Br): TI defines "Green" to mean Pb-Free (RoHS compatible), and free of Bromine (Br) and Antimony (Sb) based flame retardants (Br or Sb do not exceed 0.1% by weight in homogeneous material)

⁽³⁾ MSL, Peak Temp. - The Moisture Sensitivity Level rating according to the JEDEC industry standard classifications, and peak solder temperature.

⁽⁴⁾ There may be additional marking, which relates to the logo, the lot trace code information, or the environmental category on the device.

⁽⁵⁾ Multiple Device Markings will be inside parentheses. Only one Device Marking contained in parentheses and separated by a "~" will appear on a device. If a line is indented then it is a continuation of the previous line and the two combined represent the entire Device Marking for that device.

⁽⁶⁾ Lead/Ball Finish - Orderable Devices may have multiple material finish options. Finish options are separated by a vertical ruled line. Lead/Ball Finish values may wrap to two lines if the finish value exceeds the maximum column width.

Important Information and Disclaimer: The information provided on this page represents TI's knowledge and belief as of the date that it is provided. TI bases its knowledge and belief on information provided by third parties, and makes no representation or warranty as to the accuracy of such information. Efforts are underway to better integrate information from third parties. TI has taken and continues to take reasonable steps to provide representative and accurate information but may not have conducted destructive testing or chemical analysis on incoming materials and chemicals. TI and TI suppliers consider certain information to be proprietary, and thus CAS numbers and other limited information may not be available for release.

In no event shall TI's liability arising out of such information exceed the total purchase price of the TI part(s) at issue in this document sold by TI to Customer on an annual basis.

TAPE AND REEL INFORMATION

QUADRANT ASSIGNMENTS FOR PIN 1 ORIENTATION IN TAPE

*All dimensions are nominal

| Device | Package Type | Package Drawing | Pins | SPQ | Reel Diameter (mm) | Reel Width W1 (mm) | A0 (mm) | B0 (mm) | K0 (mm) | P1 (mm) | W (mm) | Pin1 Quadrant |
|--------------|--------------|-----------------|------|------|--------------------|--------------------|---------|---------|---------|---------|--------|---------------|
| AMC1203BDUBR | SOP | DUB | 8 | 350 | 330.0 | 24.4 | 10.9 | 10.01 | 5.85 | 16.0 | 24.0 | Q1 |
| AMC1203BDWR | SOIC | DW | 16 | 2000 | 330.0 | 16.4 | 10.75 | 10.7 | 2.7 | 12.0 | 16.0 | Q1 |
| AMC1203BPSAR | SOP | PSA | 8 | 2000 | 330.0 | 16.4 | 8.3 | 5.7 | 2.3 | 12.0 | 16.0 | Q1 |
| AMC1203DUBR | SOP | DUB | 8 | 350 | 330.0 | 24.4 | 10.9 | 10.01 | 5.85 | 16.0 | 24.0 | Q1 |
| AMC1203DWR | SOIC | DW | 16 | 2000 | 330.0 | 16.4 | 10.75 | 10.7 | 2.7 | 12.0 | 16.0 | Q1 |
| AMC1203PSAR | SOP | PSA | 8 | 2000 | 330.0 | 16.4 | 8.3 | 5.7 | 2.3 | 12.0 | 16.0 | Q1 |

TAPE AND REEL BOX DIMENSIONS



*All dimensions are nominal

| Device | Package Type | Package Drawing | Pins | SPQ | Length (mm) | Width (mm) | Height (mm) |
|--------------|--------------|-----------------|------|------|-------------|------------|-------------|
| AMC1203BDUBR | SOP | DUB | 8 | 350 | 358.0 | 335.0 | 35.0 |
| AMC1203BDWR | SOIC | DW | 16 | 2000 | 367.0 | 367.0 | 38.0 |
| AMC1203BPSAR | SOP | PSA | 8 | 2000 | 358.0 | 335.0 | 35.0 |
| AMC1203DUBR | SOP | DUB | 8 | 350 | 406.0 | 348.0 | 63.0 |
| AMC1203DWR | SOIC | DW | 16 | 2000 | 367.0 | 367.0 | 38.0 |
| AMC1203PSAR | SOP | PSA | 8 | 2000 | 358.0 | 335.0 | 35.0 |

DUB (R-PDSO-G8)

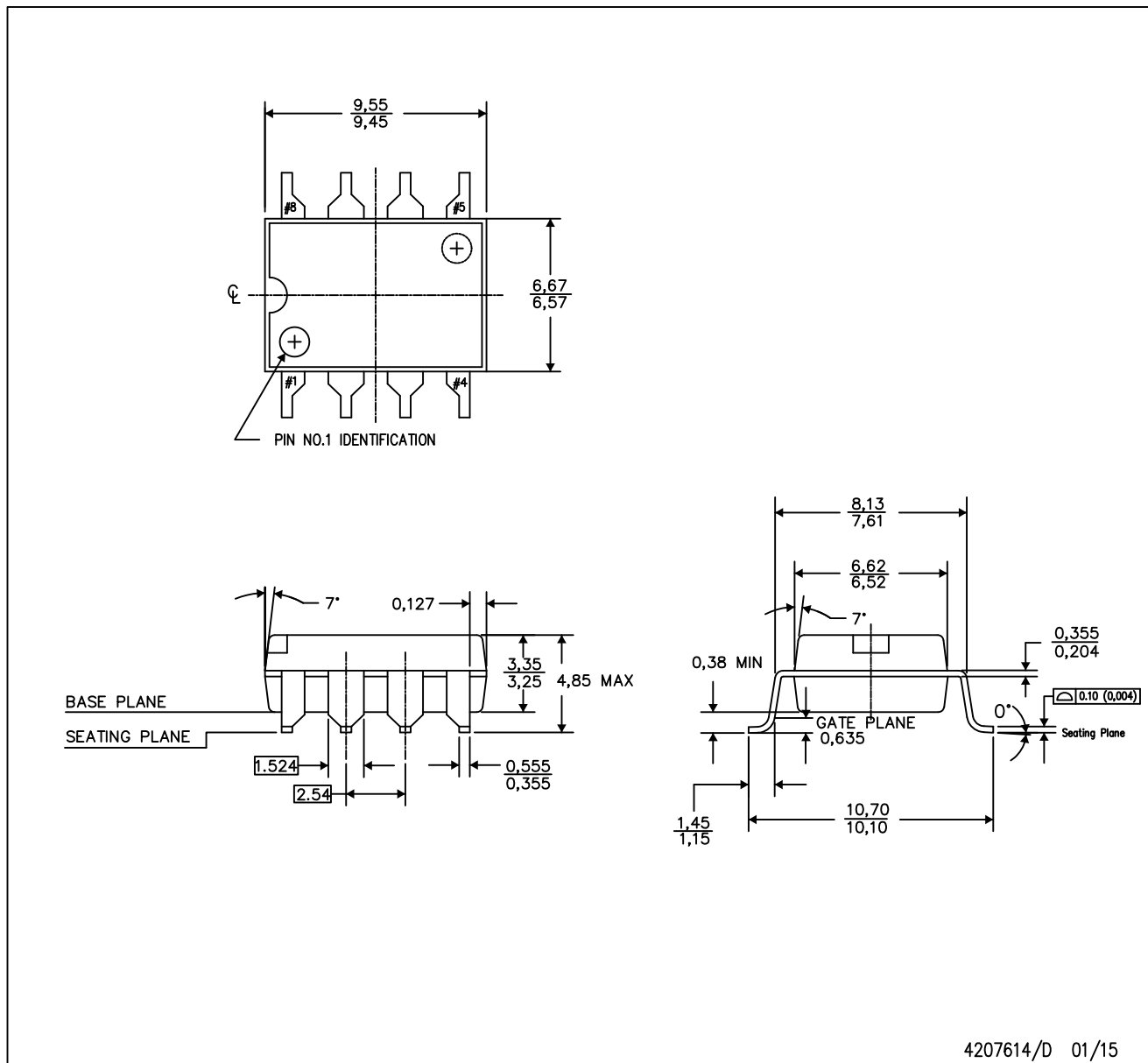
PLASTIC SMALL-OUTLINE



- NOTES:
- A. All linear dimensions are in millimeters. Dimensioning and tolerancing per ANSI Y14.5 M-1982.
 - B. This drawing is subject to change without notice.
 -  Dimensions do not include mold flash or protrusions. Mold flash or protrusions shall not exceed 0.254mm.

DUB (R-PDSO-G8)

PLASTIC SMALL OUTLINE

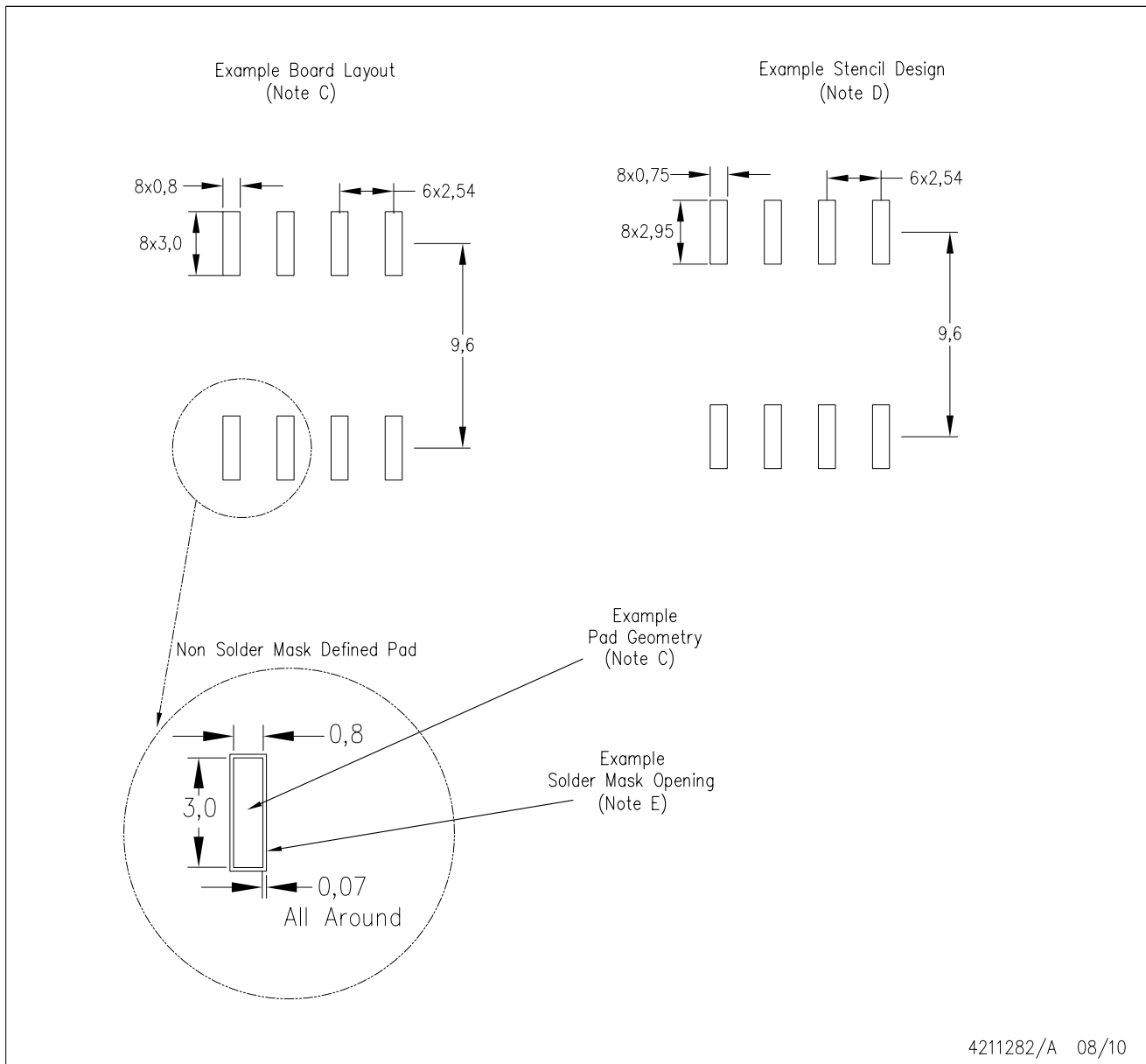

- NOTES:
- A. All linear dimensions are in millimeters.
 - B. This drawing is subject to change without notice.
 - C. Publication IPC-7351 is recommended for alternate designs.
 - D. Laser cutting apertures with trapezoidal walls and also rounding corners will offer better paste release. Customers should contact their board assembly site for stencil design recommendations. Refer to IPC-7525.
 - E. Customers should contact their board fabrication site for solder mask tolerances between and around signal pads.

PSA (R-PDSO-G8)

PLASTIC SMALL-OUTLINE PACKAGE

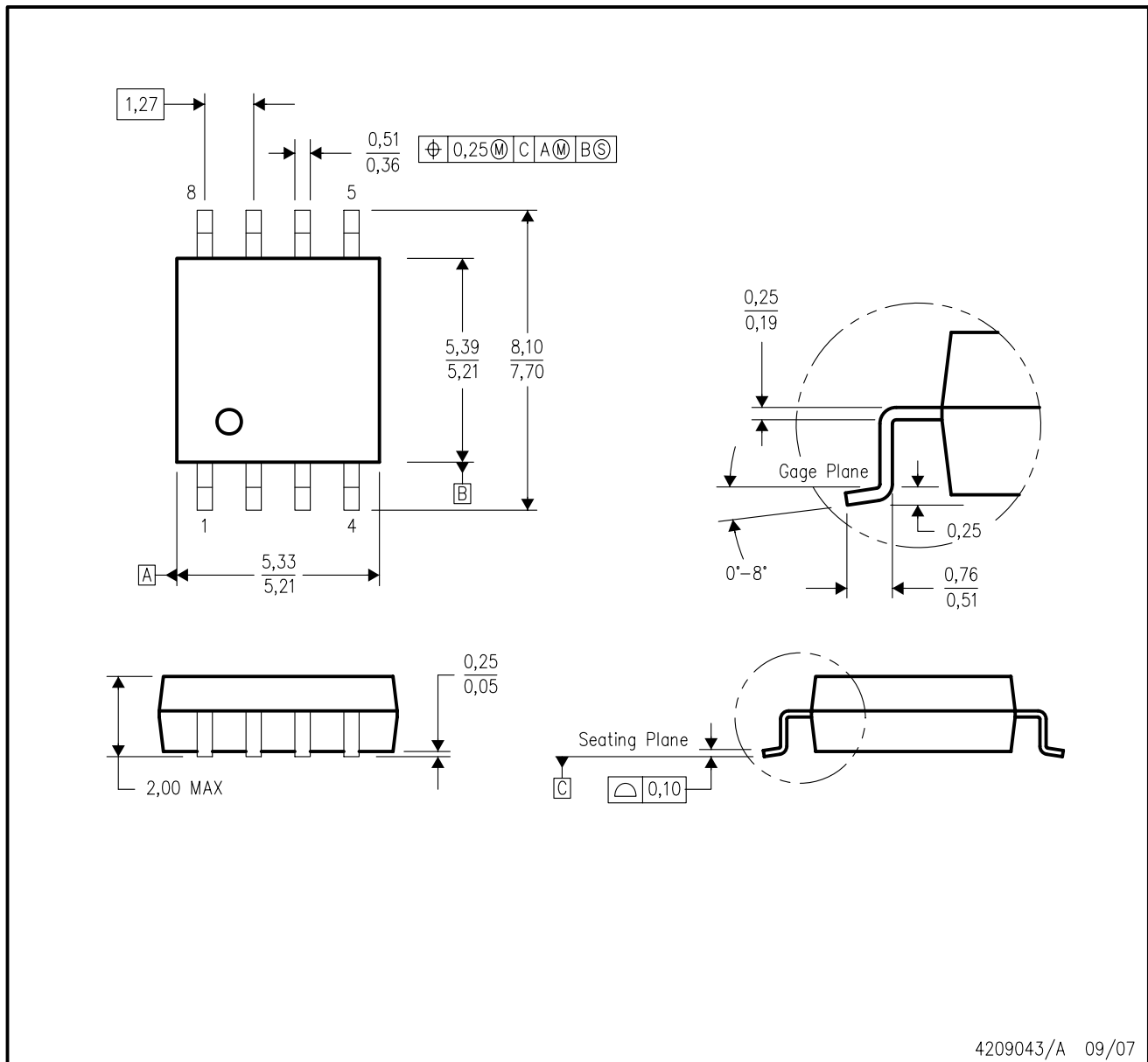

4209043/A 09/07

- NOTES:
- A. All linear dimensions are in millimeters.
 - B. This drawing is subject to change without notice.
 - C. Body dimensions do not include mold flash or protrusion, not to exceed 0,15.

DW (R-PDSO-G16)

PLASTIC SMALL OUTLINE

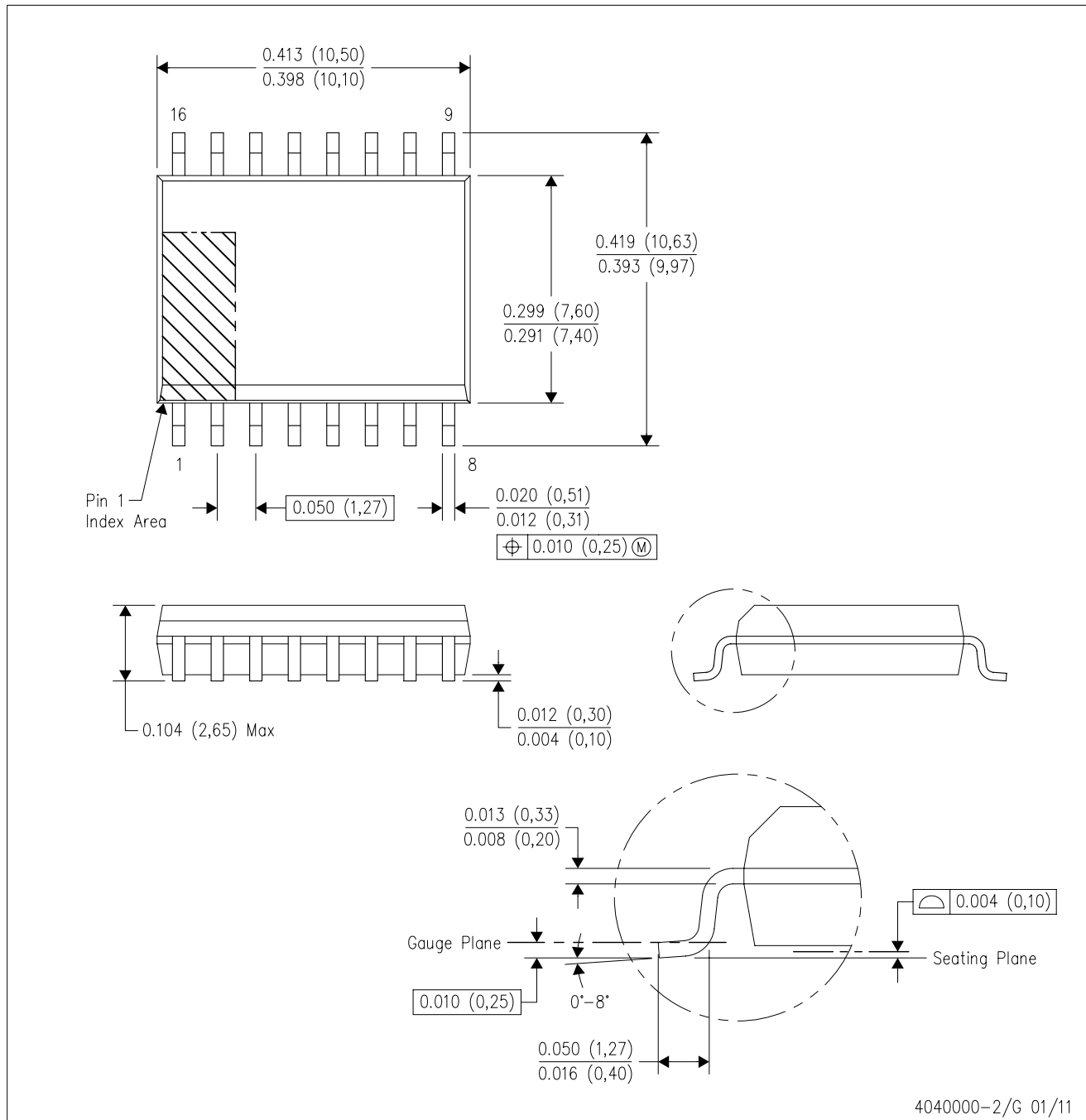

- NOTES:
- A. All linear dimensions are in inches (millimeters). Dimensioning and tolerancing per ASME Y14.5M-1994.
 - B. This drawing is subject to change without notice.
 - C. Body dimensions do not include mold flash or protrusion not to exceed 0.006 (0,15).
 - D. Falls within JEDEC MS-013 variation AA.

DW (R-PDSO-G16)

PLASTIC SMALL OUTLINE

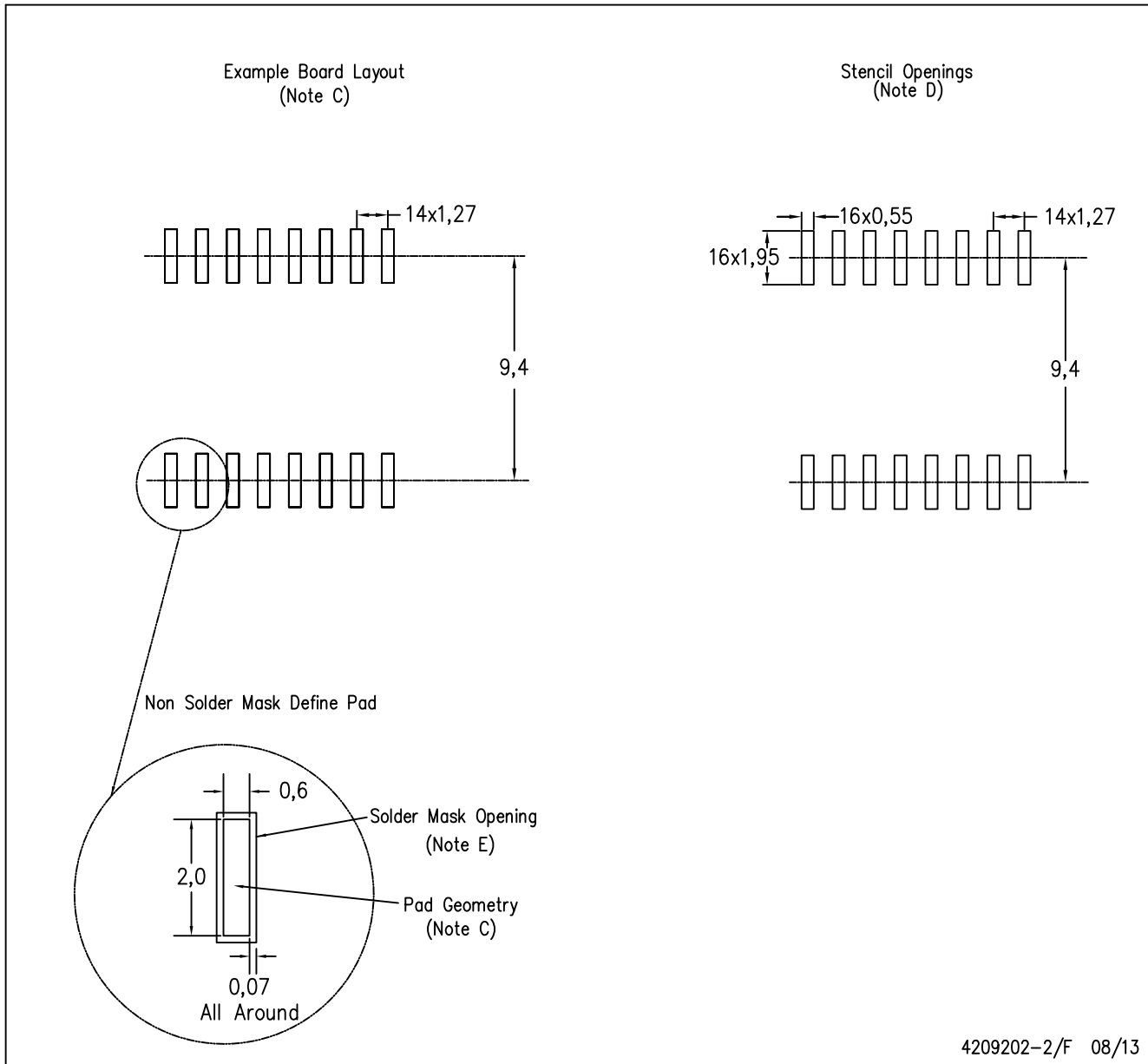

4209202-2/F 08/13

- NOTES:
- A. All linear dimensions are in millimeters.
 - B. This drawing is subject to change without notice.
 - C. Refer to IPC7351 for alternate board design.
 - D. Laser cutting apertures with trapezoidal walls and also rounding corners will offer better paste release. Customers should contact their board assembly site for stencil design recommendations. Refer to IPC-7525
 - E. Customers should contact their board fabrication site for solder mask tolerances between and around signal pads.

IMPORTANT NOTICE

Texas Instruments Incorporated and its subsidiaries (TI) reserve the right to make corrections, enhancements, improvements and other changes to its semiconductor products and services per JESD46, latest issue, and to discontinue any product or service per JESD48, latest issue. Buyers should obtain the latest relevant information before placing orders and should verify that such information is current and complete. All semiconductor products (also referred to herein as "components") are sold subject to TI's terms and conditions of sale supplied at the time of order acknowledgment.

TI warrants performance of its components to the specifications applicable at the time of sale, in accordance with the warranty in TI's terms and conditions of sale of semiconductor products. Testing and other quality control techniques are used to the extent TI deems necessary to support this warranty. Except where mandated by applicable law, testing of all parameters of each component is not necessarily performed.

TI assumes no liability for applications assistance or the design of Buyers' products. Buyers are responsible for their products and applications using TI components. To minimize the risks associated with Buyers' products and applications, Buyers should provide adequate design and operating safeguards.

TI does not warrant or represent that any license, either express or implied, is granted under any patent right, copyright, mask work right, or other intellectual property right relating to any combination, machine, or process in which TI components or services are used. Information published by TI regarding third-party products or services does not constitute a license to use such products or services or a warranty or endorsement thereof. Use of such information may require a license from a third party under the patents or other intellectual property of the third party, or a license from TI under the patents or other intellectual property of TI.

Reproduction of significant portions of TI information in TI data books or data sheets is permissible only if reproduction is without alteration and is accompanied by all associated warranties, conditions, limitations, and notices. TI is not responsible or liable for such altered documentation. Information of third parties may be subject to additional restrictions.

Resale of TI components or services with statements different from or beyond the parameters stated by TI for that component or service voids all express and any implied warranties for the associated TI component or service and is an unfair and deceptive business practice. TI is not responsible or liable for any such statements.

Buyer acknowledges and agrees that it is solely responsible for compliance with all legal, regulatory and safety-related requirements concerning its products, and any use of TI components in its applications, notwithstanding any applications-related information or support that may be provided by TI. Buyer represents and agrees that it has all the necessary expertise to create and implement safeguards which anticipate dangerous consequences of failures, monitor failures and their consequences, lessen the likelihood of failures that might cause harm and take appropriate remedial actions. Buyer will fully indemnify TI and its representatives against any damages arising out of the use of any TI components in safety-critical applications.

In some cases, TI components may be promoted specifically to facilitate safety-related applications. With such components, TI's goal is to help enable customers to design and create their own end-product solutions that meet applicable functional safety standards and requirements. Nonetheless, such components are subject to these terms.

No TI components are authorized for use in FDA Class III (or similar life-critical medical equipment) unless authorized officers of the parties have executed a special agreement specifically governing such use.

Only those TI components which TI has specifically designated as military grade or "enhanced plastic" are designed and intended for use in military/aerospace applications or environments. Buyer acknowledges and agrees that any military or aerospace use of TI components which have **not** been so designated is solely at the Buyer's risk, and that Buyer is solely responsible for compliance with all legal and regulatory requirements in connection with such use.

TI has specifically designated certain components as meeting ISO/TS16949 requirements, mainly for automotive use. In any case of use of non-designated products, TI will not be responsible for any failure to meet ISO/TS16949.

Products

| | |
|------------------------------|--|
| Audio | www.ti.com/audio |
| Amplifiers | amplifier.ti.com |
| Data Converters | dataconverter.ti.com |
| DLP® Products | www.dlp.com |
| DSP | dsp.ti.com |
| Clocks and Timers | www.ti.com/clocks |
| Interface | interface.ti.com |
| Logic | logic.ti.com |
| Power Mgmt | power.ti.com |
| Microcontrollers | microcontroller.ti.com |
| RFID | www.ti-rfid.com |
| OMAP Applications Processors | www.ti.com/omap |
| Wireless Connectivity | www.ti.com/wirelessconnectivity |

Applications

| | |
|-------------------------------|--|
| Automotive and Transportation | www.ti.com/automotive |
| Communications and Telecom | www.ti.com/communications |
| Computers and Peripherals | www.ti.com/computers |
| Consumer Electronics | www.ti.com/consumer-apps |
| Energy and Lighting | www.ti.com/energy |
| Industrial | www.ti.com/industrial |
| Medical | www.ti.com/medical |
| Security | www.ti.com/security |
| Space, Avionics and Defense | www.ti.com/space-avionics-defense |
| Video and Imaging | www.ti.com/video |

TI E2E Community

e2e.ti.com