

Am29LV640D/Am29LV64ID

Data Sheet



July 2003

The following document specifies Spansion memory products that are now offered by both Advanced Micro Devices and Fujitsu. Although the document is marked with the name of the company that originally developed the specification, these products will be offered to customers of both AMD and Fujitsu.

Continuity of Specifications

There is no change to this datasheet as a result of offering the device as a Spansion product. Any changes that have been made are the result of normal datasheet improvement and are noted in the document revision summary, where supported. Future routine revisions will occur when appropriate, and changes will be noted in a revision summary.

Continuity of Ordering Part Numbers

AMD and Fujitsu continue to support existing part numbers beginning with "Am" and "MBM". To order these products, please use only the Ordering Part Numbers listed in this document.

For More Information

Please contact your local AMD or Fujitsu sales office for additional information about Spansion memory solutions.

Publication Number **22366** Revision **C** Amendment **5** Issue Date **December 23, 2005**



THIS PAGE LEFT INTENTIONALLY BLANK.



Am29LV640D/Am29LV641D

64 Megabit (4 M x 16-Bit) CMOS 3.0 Volt-only Uniform Sector Flash Memory with VersatileIO™ Control

DISTINCTIVE CHARACTERISTICS

- **Single power supply operation**
 - 3.0 to 3.6 volt read, erase, and program operations
- **VersatileIO™ control**
 - Device generates output voltages and tolerates data input voltages on the DQ input/outputs as determined by the voltage on V_{IO}
- **High performance**
 - Access times as fast as 90 ns
- **Manufactured on 0.23 μ m process technology**
- **CFI (Common Flash Interface) compliant**
 - Provides device-specific information to the system, allowing host software to easily reconfigure for different Flash devices
- **SecSi (Secured Silicon) Sector region**
 - 128-word sector for permanent, secure identification through an 8-word random Electronic Serial Number
 - May be programmed and locked at the factory or by the customer
 - Accessible through a command sequence
- **Ultra low power consumption (typical values at 3.0 V, 5 MHz)**
 - 9 mA typical active read current
 - 26 mA typical erase/program current
 - 200 nA typical standby mode current
- **Flexible sector architecture**
 - One hundred twenty-eight 32 Kword sectors
- **Sector Protection**
 - A hardware method to lock a sector to prevent program or erase operations within that sector
 - Sectors can be locked in-system or via programming equipment
 - Temporary Sector Unprotect feature allows code changes in previously locked sectors
- **Embedded Algorithms**
 - Embedded Erase algorithm automatically preprograms and erases the entire chip or any combination of designated sectors
 - Embedded Program algorithm automatically writes and verifies data at specified addresses
- **Compatibility with JEDEC standards**
 - Pinout and software compatible with single-power supply Flash
 - Superior inadvertent write protection
- **Minimum 1 million erase cycle guarantee per sector**
- **Package options**
 - 48-pin TSOP (Am29LV641DH/DL only)
 - 56-pin SSOP (Am29LV640DH/DL only)
 - 63-ball Fine-Pitch BGA (Am29LV640DU only)
 - 64-ball Fortified BGA (Am29LV640DU only)
- **Erase Suspend/Erase Resume**
 - Suspends an erase operation to read data from, or program data to, a sect27
 - or that is not being erased, then resumes the erase operation
- **Data# Polling and toggle bits**
 - Provides a software method of detecting program or erase operation completion
- **Unlock Bypass Program command**
 - Reduces overall programming time when issuing multiple program command sequences
- **Ready/Busy# pin (RY/BY#) (Am29LV640DU in FBGA package only)**
 - Provides a hardware method of detecting program or erase cycle completion
- **Hardware reset pin (RESET#)**
 - Hardware method to reset the device for reading array data
- **WP# pin (Am29LV641DH/DL in TSOP, Am29LV640DH/DL in SSOP only)**
 - At V_{IL} , protects the first or last 32 Kword sector, regardless of sector protect/unprotect status
 - At V_{IH} , allows removal of sector protection
 - An internal pull up to V_{CC} is provided
- **ACC pin**
 - Accelerates programming time for higher throughput during system production
- **Program and Erase Performance (V_{HH} not applied to the ACC input pin)**
 - Word program time: 11 μ s typical
 - Sector erase time: 0.9 s typical for each 32 Kword sector

GENERAL DESCRIPTION

The Am29LV640DU/Am29LV641DU is a 64 Mbit, 3.0 Volt (3.0 V to 3.6 V) single power supply flash memory device organized as 4,194,304 words. Data appears on DQ0-DQ15. The device is designed to be programmed in-system with the standard system 3.0 volt V_{CC} supply. A 12.0 volt V_{PP} is not required for program or erase operations. You can also program this device in standard EPROM programmers.

Access times of 90 and 120 ns are available for applications where $V_{IO} \geq V_{CC}$. An access time 120 ns are available for applications where $V_{IO} < V_{CC}$. The device is offered in 48-pin TSOP, 56-pin SSOP, 63-ball Fine-Pitch BGA and 64-ball Fortified BGA packages. To eliminate bus contention, each device has separate chip enable (CE#), write enable (WE#), and output enable (OE#) controls.

Each device requires only a **single 3.0 Volt power supply** (3.0 V to 3.6 V) for both read and write functions. Internally generated and regulated voltages are provided for the program and erase operations.

The device is entirely command set compatible with the **JEDEC single-power-supply Flash standard**. Commands are written to the command register using standard microprocessor write timing. Register contents serve as inputs to an internal state-machine that controls the erase and programming circuitry. Write cycles also internally latch addresses and data needed for the programming and erase operations. Reading data out of the device is similar to reading from other Flash or EPROM devices.

Device programming occurs by executing the program command sequence. This initiates the **Embedded Program** algorithm — an internal algorithm that automatically times the program pulse widths and verifies proper cell margin. The Unlock Bypass mode facilitates faster programming times by requiring only two write cycles to program data instead of four.

Device erasure occurs by executing the erase command sequence. This initiates the **Embedded Erase** algorithm — an internal algorithm that automatically preprograms the array (if it is not already programmed) before executing the erase operation. During erase, the device automatically times the erase pulse widths and verifies proper cell margin.

The **VersatileIO™** (V_{IO}) control allows the host system to set the voltage levels that the device generates and tolerates on CE# and DQ I/Os to the same voltage level that is asserted on V_{IO} . V_{IO} is available in two configurations (1.8–2.9 V and 3.0–5.0 V) for operation in various system environments.

The host system can detect whether a program or erase operation is complete by observing the RY/BY# pin, by reading the DQ7 (Data# Polling), or DQ6 (tog-

gle) **status bits**. After a program or erase cycle completes, the device is ready to read array data or accept another command.

The **sector erase architecture** allows memory sectors to be erased and reprogrammed without affecting the data contents of other sectors. The device is fully erased when shipped from the factory.

Hardware data protection measures include a low V_{CC} detector that automatically inhibits write operations during power transitions. The hardware sector protection feature disables both program and erase operations in any combination of sectors of memory. This is achieved in-system or via programming equipment.

The **Erase Suspend/Erase Resume** feature enables the user to put erase on hold for any period of time to read data from, or program data to, any sector that is not selected for erasure. True background erase can thus be achieved.

The **hardware RESET# pin** terminates any operation in progress and resets the internal state machine to reading array data. The RESET# pin can be tied to the system reset circuitry. A system reset would thus also reset the device, enabling the system microprocessor to read boot-up firmware from the Flash memory device.

The device offers a **standby mode** as a power-saving feature. Once the system places the device into the standby mode, power consumption is greatly reduced.

The **SecSi (Secured Silicon) Sector** provides a minimum 128-word area for code or data that can be permanently protected. Once this sector is protected, no further programming or erasing within the sector can occur.

The **Write Protect (WP#)** feature protects the first or last sector by asserting a logic low on the WP# pin. The protected sector is still protected even during accelerated programming.

The **accelerated program (ACC)** feature allows the system to program the device at a much faster rate. When ACC is pulled high to V_{HH} , the device enters the Unlock Bypass mode, enabling the user to reduce the time needed to do the program operation. This feature is intended to increase factory throughput during system production, but may also be used in the field if desired.

AMD's Flash technology combines years of Flash memory manufacturing experience to produce the highest levels of quality, reliability and cost effectiveness. The device electrically erases all bits within a sector simultaneously via Fowler-Nordheim tunnelling. The data is programmed using hot electron injection.

TABLE OF CONTENTS

Product Selector Guide	4	RY/BY#: Ready/Busy#	30
Block Diagram	4	DQ6: Toggle Bit I	30
Connection Diagrams	5	Figure 6. Toggle Bit Algorithm.....	30
Special Handling Instructions for FBGA/BGA Packages	7	DQ2: Toggle Bit II	31
Pin Description	8	Reading Toggle Bits DQ6/DQ2	31
Logic Symbol	8	DQ5: Exceeded Timing Limits	31
Ordering Information	9	DQ3: Sector Erase Timer	31
Device Bus Operations	10	Table 11. Write Operation Status	32
Table 1. Device Bus Operations	10	Absolute Maximum Ratings	33
VersatileIO™ (V _{IO}) Control	10	Figure 7. Maximum Negative Overshoot Waveform	33
Requirements for Reading Array Data	10	Figure 8. Maximum Positive Overshoot Waveform.....	33
Writing Commands/Command Sequences	11	Operating Ranges	33
Accelerated Program Operation	11	DC Characteristics	34
Autoselect Functions	11	Figure 9. I _{CC1} Current vs. Time (Showing	
Standby Mode	11	Active and Automatic Sleep Currents)	35
Automatic Sleep Mode	11	Figure 10. Typical I _{CC1} vs. Frequency	35
RESET#: Hardware Reset Pin	11	Test Conditions	36
Output Disable Mode	12	Figure 11. Test Setup.....	36
Table 2. Sector Address Table	12	Table 12. Test Specifications	36
Autoselect Mode	16	Key to Switching Waveforms.	36
Table 3. Autoselect Codes, (High Voltage Method)	16	Figure 12. Input Waveforms and	
Sector Group Protection and Unprotection	17	Measurement Levels.....	36
Table 4. Sector Group Protection/Unprotection Address Table	17	AC Characteristics	37
Write Protect (WP#)	18	Read-Only Operations	37
Temporary Sector Group Unprotect	18	Figure 13. Read Operation Timings.....	37
Figure 1. Temporary Sector Group Unprotect Operation.....	18	Hardware Reset (RESET#)	38
Figure 2. In-System Sector Group Protect/Unprotect Algorithms ...	19	Figure 14. Reset Timings	38
SecSi (Secured Silicon) Sector Flash Memory Region	20	Erase and Program Operations	39
Table 5. SecSi Sector Contents	20	Figure 15. Program Operation Timings.....	40
Hardware Data Protection	20	Figure 16. Accelerated Program Timing Diagram.....	40
Low VCC Write Inhibit	20	Figure 17. Chip/Sector Erase Operation Timings	41
Write Pulse “Glitch” Protection	21	Figure 18. Data# Polling Timings	
Logical Inhibit	21	(During Embedded Algorithms).....	42
Power-Up Write Inhibit	21	Figure 19. Toggle Bit Timings	
Common Flash Memory Interface (CFI)	21	(During Embedded Algorithms).....	43
Table 6. CFI Query Identification String.....	21	Figure 20. DQ2 vs. DQ6.....	43
System Interface String.....	22	Temporary Sector Unprotect	44
Table 8. Device Geometry Definition	22	Figure 21. Temporary Sector Group Unprotect Timing Diagram ...	44
Table 9. Primary Vendor-Specific Extended Query	23	Figure 22. Sector Group Protect and Unprotect Timing Diagram ..	45
Command Definitions	23	Alternate CE# Controlled Erase and Program Operations	46
Reading Array Data	23	Figure 23. Alternate CE# Controlled Write	
Reset Command	24	(Erase/Program) Operation Timings	47
Autoselect Command Sequence	24	Erase And Programming Performance	48
Enter SecSi Sector/Exit SecSi Sector Command Sequence	24	Latchup Characteristics	48
Word Program Command Sequence	24	TSOP Pin Capacitance	48
Unlock Bypass Command Sequence	25	Data Retention.	48
Figure 3. Program Operation	25	Physical Dimensions	49
Chip Erase Command Sequence	25	SSO056—56-Pin Shrink Small Outline Package (SSOP)	49
Sector Erase Command Sequence	26	FBE063—63-Ball Fine-Pitch Ball Grid Array	
Erase Suspend/Erase Resume Commands	26	(FBGA) 12 x 11 mm package	50
Figure 4. Erase Operation.....	27	LAA064—64-Ball Fortified Ball Grid Array	
Command Definitions	28	(FBGA) 13 x 11 mm package	51
Command Definitions.....	28	TS 048—48-Pin Standard TSOP	52
Write Operation Status	29	Revision Summary	53
DQ7: Data# Polling	29		
Figure 5. Data# Polling Algorithm	29		

PRODUCT SELECTOR GUIDE

Part Number		Am29LV640D/Am29LV641D	
Speed Option	$V_{CC} = 3.0\text{--}3.6\text{ V}$, $V_{IO} = 3.0\text{--}5.0\text{ V}$	90R	120R
	$V_{CC} = 3.0\text{--}3.6\text{ V}$, $V_{IO} = 1.8\text{--}2.9\text{ V}$		121R
Max Access Time (ns)		90	120
CE# Access Time (ns)		90	120
OE# Access Time (ns)		35	50

Note: See “AC Characteristics” for full specifications.

BLOCK DIAGRAM

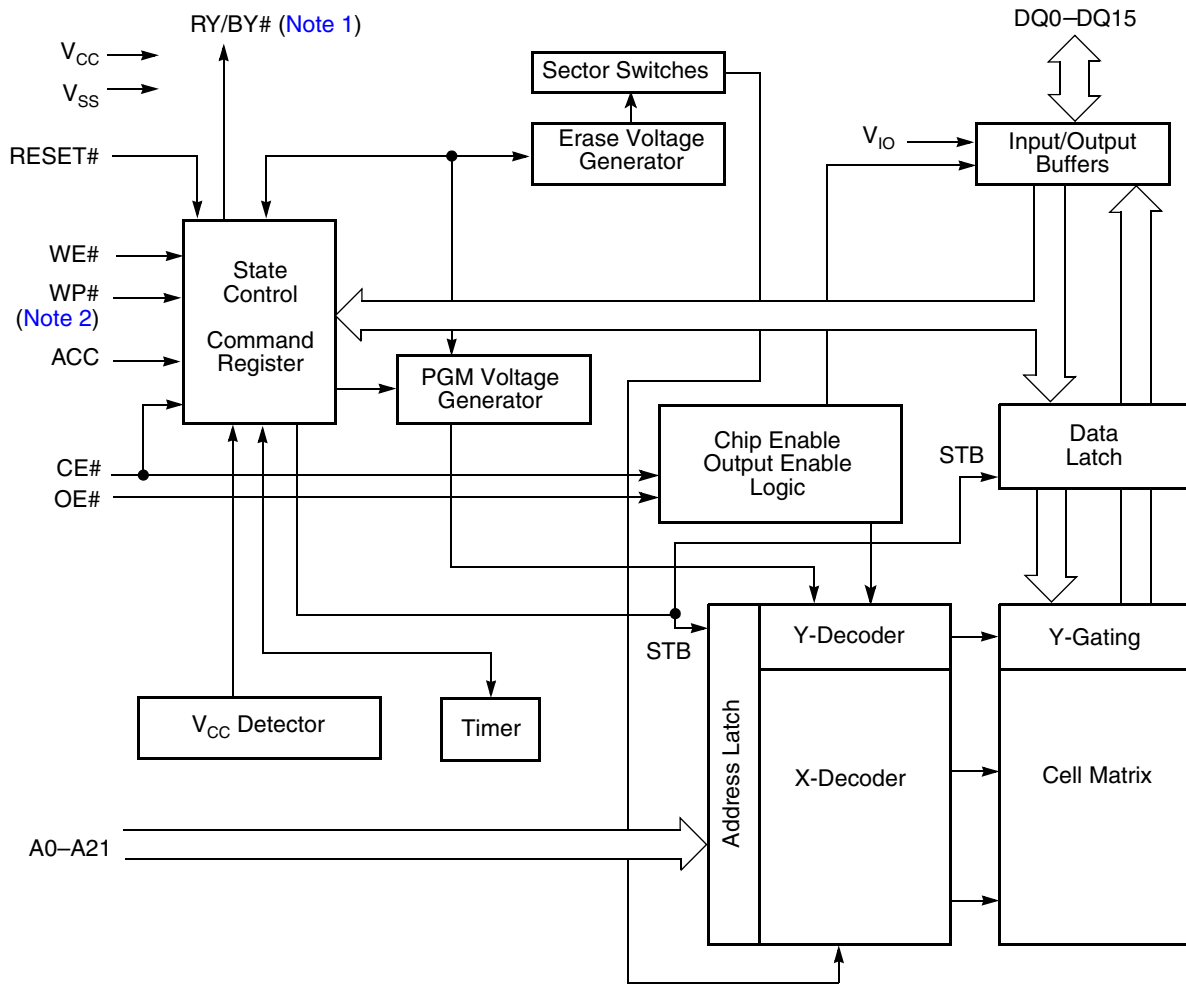

Notes:

1. RY/BY# is only available in the FBGA package.
2. WP# is only available in the TSOP and SSOP packages.

CONNECTION DIAGRAMS

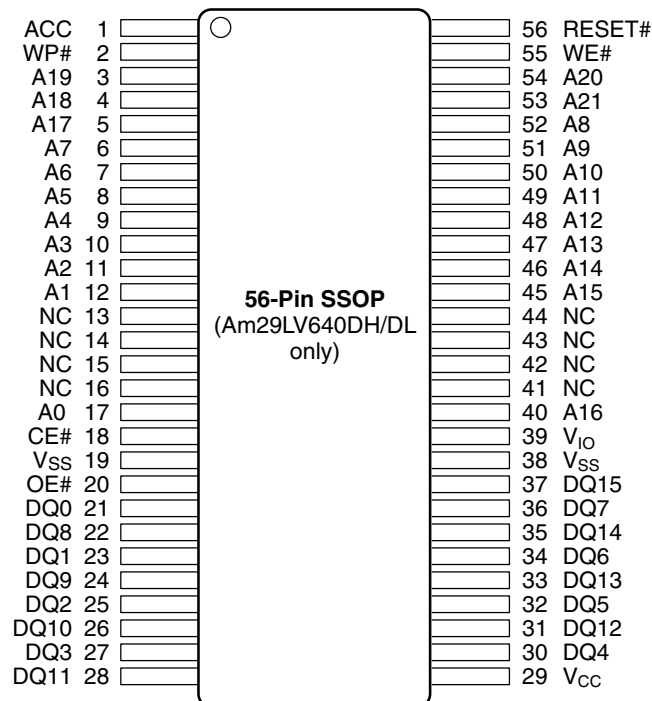
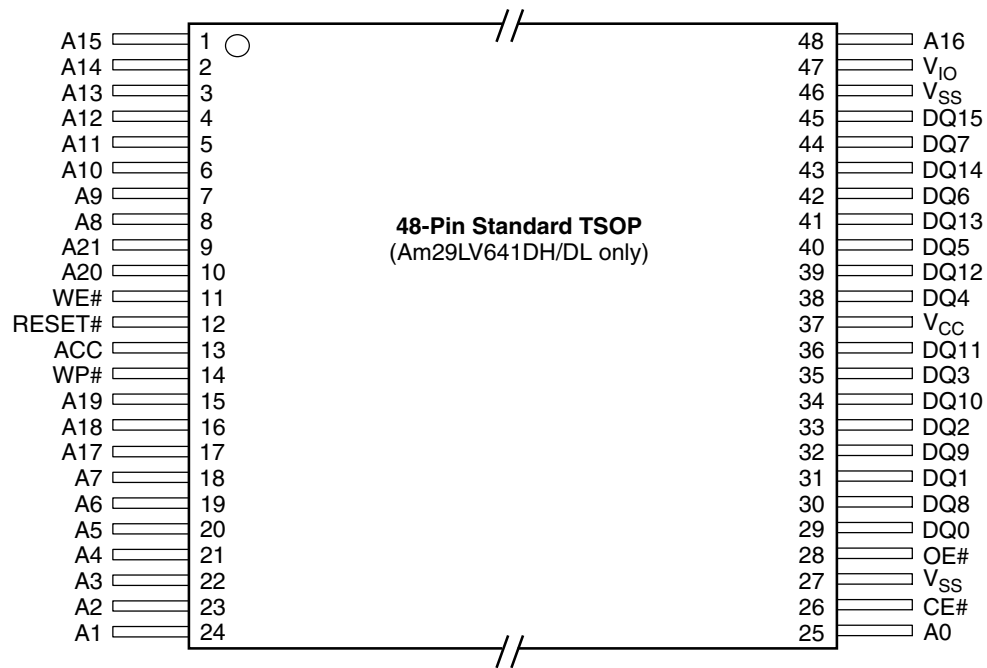

CONNECTION DIAGRAM

63-Ball Fine-Pitch BGA (FBGA)
 Top View, Balls Facing Down
 (Am29LV640DU only)

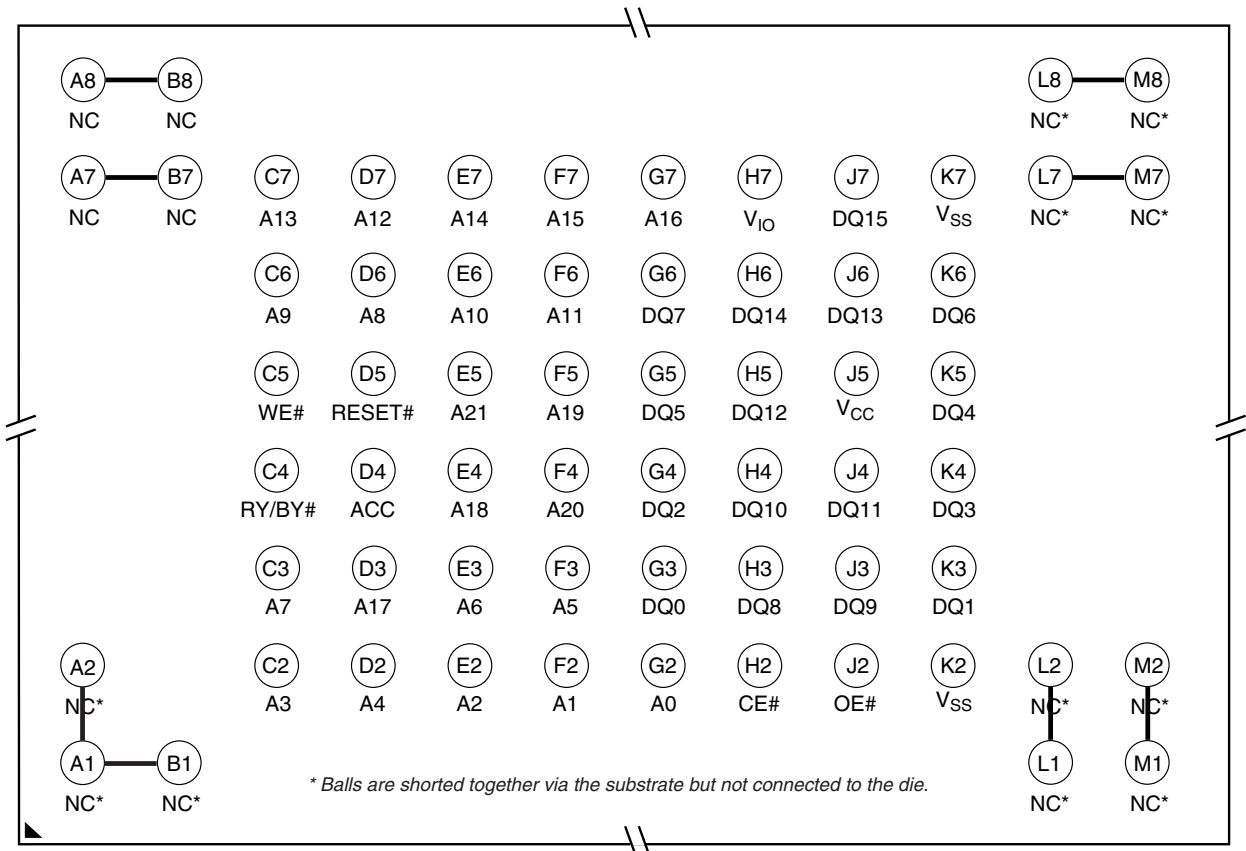

CONNECTION DIAGRAMS

64-Ball Fortified BGA (FBGA)
 Top View, Balls Facing Down
 (Am29LV640DU only)

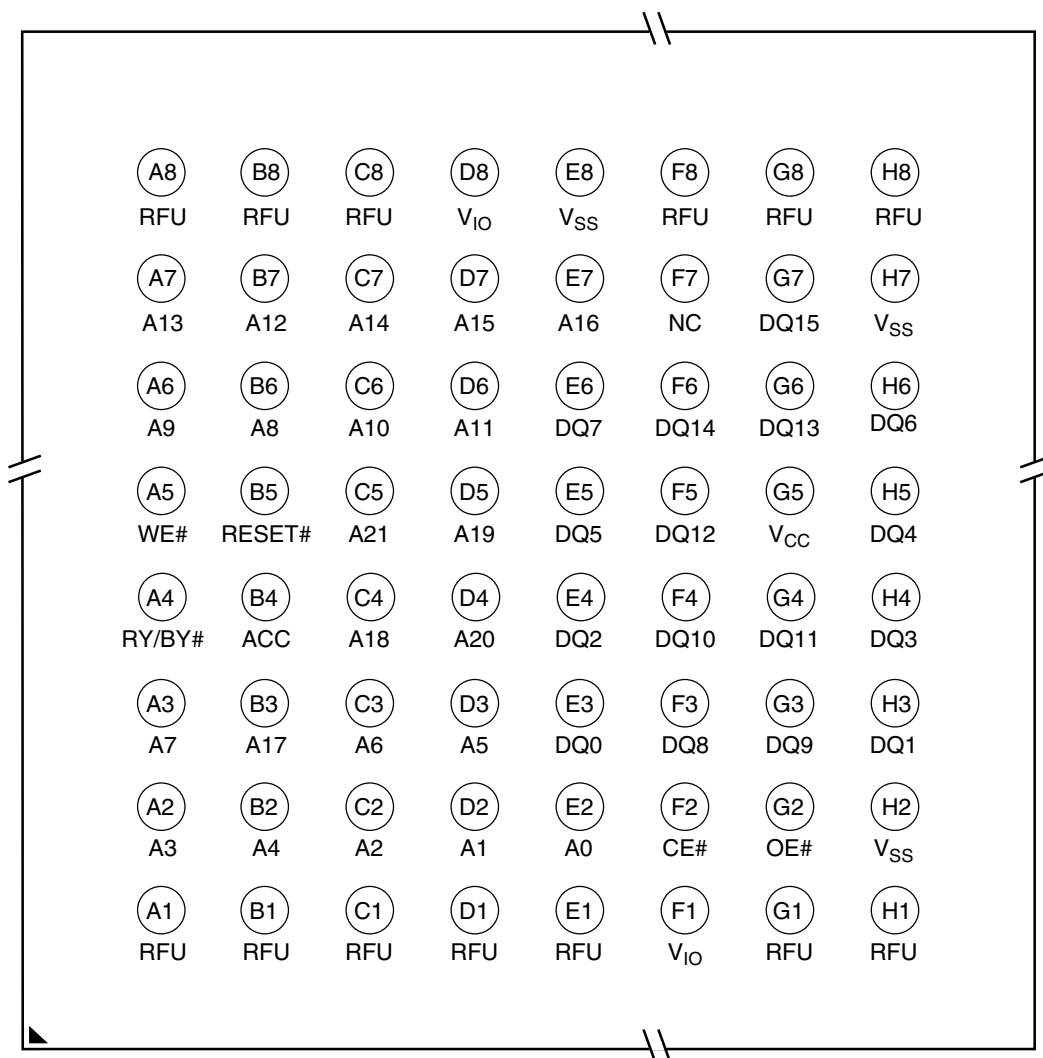

Special Handling Instructions for FBGA/FGA Packages

Special handling is required for Flash Memory products in BGA packages.

Flash memory devices in BGA packages may be damaged if exposed to ultrasonic cleaning methods. The package and/or data integrity may be compromised if the package body is exposed to temperatures above 150°C for prolonged periods of time.

PIN DESCRIPTION

A0–A21	= 22 Addresses inputs
DQ0–DQ15	= 16 Data inputs/outputs
CE#	= Chip Enable input
OE#	= Output Enable input
WE#	= Write Enable input
WP#	= Hardware Write Protect input (N/A on FBGA)
ACC	= Acceleration Input
RESET#	= Hardware Reset Pin input
RY/BY#	= Ready/Busy output (FBGA only)
V _{CC}	= 3.0 volt-only single power supply (see Product Selector Guide for speed options and voltage supply tolerances)
V _{IO}	= Output Buffer power
V _{SS}	= Device Ground
NC	= Pin Not Connected Internally
RFU	= Reserved for Future Use

LOGIC SYMBOL

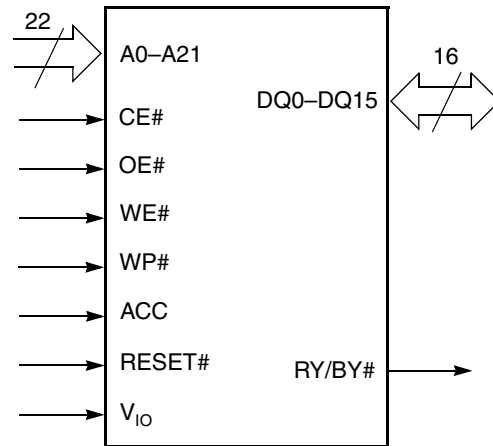

Note: WP# is not available on the FBGA package. RY/BY# is not available on the TSOP and SSOP packages.

ORDERING INFORMATION

Standard Products

AMD standard products are available in several packages and operating ranges. The order number (Valid Combination) is formed by a combination of the following:

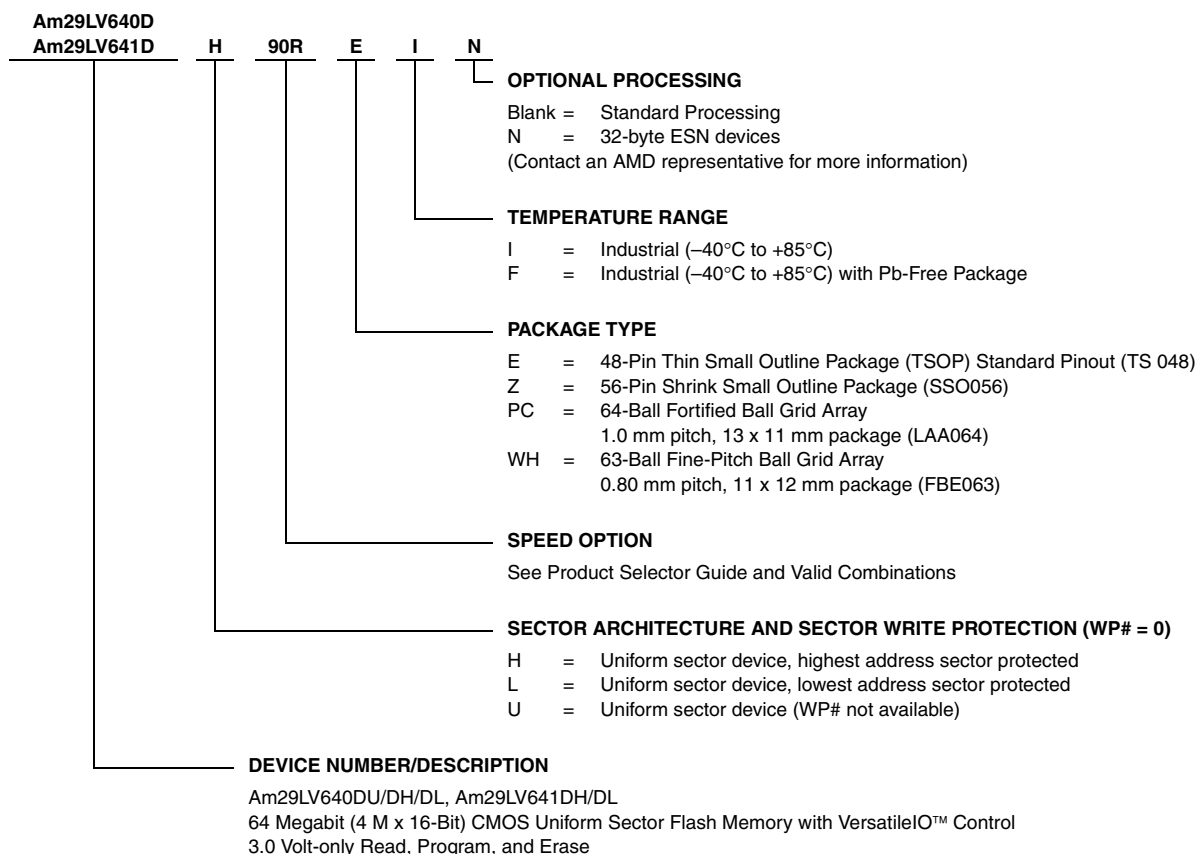

Valid Combinations for TSOP and SSOP Packages		Speed/V _{IO} Range
AM29LV640DH90R, AM29LV640DL90R	ZI, ZF	90 ns, V _{IO} = 3.0 V – 5.0 V
AM29LV641DH90R, AM29LV641DL90R	EI, FI, EF	
AM29LV640DH120R, AM29LV640DL120R	ZI, ZF	120 ns, V _{IO} = 3.0 V – 5.0 V
AM29LV641DH120R, AM29LV641DL120R	EI, FI, EF	
AM29LV640DH121R, AM29LV640DL121R	ZI, ZF	120 ns, V _{IO} = 1.8 V – 2.9 V
AM29LV641DH121R, AM29LV641DL121R	EI, FI, EF	

Note: LV640/641DH & DL have WP#, but no RY/BY#. U designator in base part number replaced by H or L.

Valid Combinations

Valid Combinations list configurations planned to be supported in volume for this device. Consult the local AMD sales office to confirm availability of specific valid combinations and to check on newly released combinations.

Valid Combinations for BGA Packages			Speed/ V _{IO} Range
Order Number	Package Marking		
AM29LV640DU90R	PCI, PCF	L640DU90N	I, F 90 ns, V _{IO} = 3.0 V – 5.0 V
	WHI, WHF	L640DU90R	
AM29LV640DU120R	PCI, PCF	L640DU12N	I, F 120 ns, V _{IO} = 3.0 V – 5.0 V
	WHI, WHF	L640DU12R	
AM29LV640DU121R	PCI, PCF	L640DU21N	I, F 120 ns, V _{IO} = 1.8 V – 2.9 V
	WHI, WHF	L640DU21R	

Note: LV640DU has RY/BY#, but no WP#.

Note: Reverse pinout TSOP (TSR048) packages are not offered for new designs. For 128 Mb requirements, the S29GL128N product is recommended as a single-device substitute for the 64 Mb + 64 Mb clamshell design; please refer to the S29GL128N data sheet for specifications and ordering information.

DEVICE BUS OPERATIONS

This section describes the requirements and use of the device bus operations, which are initiated through the internal command register. The command register itself does not occupy any addressable memory location. The register is a latch used to store the commands, along with the address and data information needed to execute the command. The contents of the

register serve as inputs to the internal state machine. The state machine outputs dictate the function of the device. [Table 1](#) lists the device bus operations, the inputs and control levels they require, and the resulting output. The following subsections describe each operation in further detail.

Table 1. Device Bus Operations

Operation	CE#	OE#	WE#	RESET#	WP#	ACC	Addresses (Note 2)	DQ0– DQ15
Read	L	L	H	H	X	X	A _{IN}	D _{OUT}
Write (Program/Erase)	L	H	L	H	(Note 3)	X	A _{IN}	(Note 4)
Accelerated Program	L	H	L	H	(Note 3)	V _{HH}	A _{IN}	(Note 4)
Standby	V _{CC} ± 0.3 V	X	X	V _{CC} ± 0.3 V	X	H	X	High-Z
Output Disable	L	H	H	H	X	X	X	High-Z
Reset	X	X	X	L	X	X	X	High-Z
Sector Group Protect (Note 2)	L	H	L	V _{ID}	H	X	SA, A6 = L, A1 = H, A0 = L	(Note 4)
Sector Group Unprotect (Note 2)	L	H	L	V _{ID}	H	X	SA, A6 = H, A1 = H, A0 = L	(Note 4)
Temporary Sector Group Unprotect	X	X	X	V _{ID}	H	X	A _{IN}	(Note 4)

Legend: L = Logic Low = V_{IL}, H = Logic High = V_{IH}, V_{ID} = 8.5–12.5 V, V_{HH} = 11.5–12.5 V, X = Don't Care, SA = Sector Address, A_{IN} = Address In, D_{IN} = Data In, D_{OUT} = Data Out

Notes:

- Addresses are A21:A0. Sector addresses are A21:A15.
- The sector protect and sector unprotect functions may also be implemented via programming equipment. See the “Sector Group Protection and Unprotection” section.
- If WP# = V_{IL}, the first or last sector remains protected. If WP# = V_{IH}, the first or last sector is protected or unprotected as determined by the method described in “Sector Group Protection and Unprotection”. All sectors are unprotected when shipped from the factory (The SecSi Sector may be factory protected depending on version ordered.)
- D_{IN} or D_{OUT} as required by command sequence, data polling, or sector protect algorithm (see [Figure 2, on page 19](#)).

VersatileIO™ (V_{IO}) Control

The VersatileIO™ (V_{IO}) control allows the host system to set the voltage levels that the device generates and tolerates on CE# and DQ I/Os to the same voltage level that is asserted on V_{IO}. V_{IO} is available in two configurations (1.8–2.9 V and 3.0–5.0 V) for operation in various system environments.

For example, a V_{IO} of 4.5–5.0 volts allows for I/O at the 5 volt level, driving and receiving signals to and from other 5 V devices on the same data bus.

Requirements for Reading Array Data

To read array data from the outputs, the system must drive the CE# and OE# pins to V_{IL}. CE# is the power control and selects the device. OE# is the output control and gates array data to the output pins. WE# should remain at V_{IH}.

The internal state machine is set for reading array data upon device power-up, or after a hardware reset. This ensures that no spurious alteration of the memory content occurs during the power transition. No command is necessary in this mode to obtain array data. Standard microprocessor read cycles that assert valid addresses on the device address inputs produce valid

data on the device data outputs. The device remains enabled for read access until the command register contents are altered.

See “Requirements for Reading Array Data” on page 10 for more information. Refer to the AC “Read-Only Operations” on page 37 table for timing specifications and to Figure 13, on page 37 for the timing diagram. I_{CC1} in the “DC Characteristics” on page 34 table represents the active current specification for reading array data.

Writing Commands/Command Sequences

To write a command or command sequence (which includes programming data to the device and erasing sectors of memory), the system must drive WE# and CE# to V_{IL} , and OE# to V_{IH} .

The device features an **Unlock Bypass** mode to facilitate faster programming. Once the device enters the Unlock Bypass mode, only two write cycles are required to program a word instead of four. The “Word Program Command Sequence” on page 24 has details on programming data to the device using both standard and Unlock Bypass command sequences.

An erase operation can erase one sector, multiple sectors, or the entire device. Table 2 on page 12 indicates the address space that each sector occupies.

I_{CC2} in the DC Characteristics table represents the active current specification for the write mode. The AC Characteristics section contains timing specification tables and timing diagrams for write operations.

Accelerated Program Operation

The device offers accelerated program operations through the ACC function. This function is primarily intended to allow faster manufacturing throughput during system production.

If the system asserts V_{HH} on this pin, the device automatically enters the aforementioned Unlock Bypass mode, temporarily unprotects any protected sectors, and uses the higher voltage on the pin to reduce the time required for program operations. The system would use a two-cycle program command sequence as required by the Unlock Bypass mode. Removing V_{HH} from the ACC pin returns the device to normal operation. *Note that the ACC pin must not be at V_{HH} for operations other than accelerated programming, or device damage may result.*

Autoselect Functions

If the system writes the autoselect command sequence, the device enters the autoselect mode. The system can then read autoselect codes from the internal register (which is separate from the memory array) on DQ7–DQ0. Standard read cycle timings apply in this mode. Refer to the “Autoselect Mode” on page 16

and “Autoselect Command Sequence” on page 24 for more information.

Standby Mode

When the system is not reading or writing to the device, it can place the device in the standby mode. In this mode, current consumption is greatly reduced, and the outputs are placed in the high impedance state, independent of the OE# input.

The device enters the CMOS standby mode when the CE# and RESET# pins are both held at $V_{CC} \pm 0.3$ V. (Note that this is a more restricted voltage range than V_{IH} .) If CE# and RESET# are held at V_{IH} , but not within $V_{CC} \pm 0.3$ V, the device is in the standby mode, but the standby current is greater. The device requires standard access time (t_{CE}) for read access when the device is in either of these standby modes before it is ready to read data.

If the device is deselected during erasure or programming, the device draws active current until the operation is completed.

I_{CC3} in the table “DC Characteristics” on page 34 represents the standby current specification.

Automatic Sleep Mode

The automatic sleep mode minimizes Flash device energy consumption. The device automatically enables this mode when addresses remain stable for $t_{ACC} + 30$ ns. The automatic sleep mode is independent of the CE#, WE#, and OE# control signals. Standard address access timings provide new data when addresses are changed. While in sleep mode, output data is latched and always available to the system. I_{CC4} in the table “DC Characteristics” on page 34 represents the automatic sleep mode current specification.

RESET#: Hardware Reset Pin

The RESET# pin provides a hardware method of resetting the device to reading array data. When the RESET# pin is driven low for at least a period of t_{RP} the device immediately terminates any operation in progress, tristates all output pins, and ignores all read/write commands for the duration of the RESET# pulse. The device also resets the internal state machine to reading array data. To ensure data integrity, the operation that was interrupted should be reinitiated once the device is ready to accept another command sequence.

Current is reduced for the duration of the RESET# pulse. When RESET# is held at $V_{SS} \pm 0.3$ V, the device draws CMOS standby current (I_{CC4}). If RESET# is held at V_{IL} but not within $V_{SS} \pm 0.3$ V, the standby current is greater.

The RESET# pin can be tied to the system reset circuitry. A system reset would thus also reset the Flash memory, enabling the system to read the boot-up firmware from the Flash memory.

If RESET# is asserted during a program or erase operation, the RY/BY# pin remains a “0” (busy) until the internal reset operation is complete, which requires a time of t_{READY} (during Embedded Algorithms). The system can thus monitor RY/BY# to determine whether the reset operation is complete. If RESET# is asserted when a program or erase operation is not executing (RY/BY# pin is “1”), the reset operation is completed

within a time of t_{READY} (not during Embedded Algorithms). The system can read data t_{RH} after the RESET# pin returns to V_{IH} .

Refer to the table “AC Characteristics” on page 37 for RESET# parameters and to Figure 14, on page 38 for the timing diagram.

Output Disable Mode

When the OE# input is at V_{IH} , output from the device is disabled. The output pins are placed in the high impedance state.

Table 2. Sector Address Table (Sheet 1 of 4)

Sector	A21	A20	A19	A18	A17	A16	A15	16-bit Address Range (in hexadecimal)
SA0	0	0	0	0	0	0	0	000000–007FFF
SA1	0	0	0	0	0	0	1	008000–00FFFF
SA2	0	0	0	0	0	1	0	010000–017FFF
SA3	0	0	0	0	0	1	1	018000–01FFFF
SA4	0	0	0	0	1	0	0	020000–027FFF
SA5	0	0	0	0	1	0	1	028000–02FFFF
SA6	0	0	0	0	1	1	0	030000–037FFF
SA7	0	0	0	0	1	1	1	038000–03FFFF
SA8	0	0	0	1	0	0	0	040000–047FFF
SA9	0	0	0	1	0	0	1	048000–04FFFF
SA10	0	0	0	1	0	1	0	050000–057FFF
SA11	0	0	0	1	0	1	1	058000–05FFFF
SA12	0	0	0	1	1	0	0	060000–067FFF
SA13	0	0	0	1	1	0	1	068000–06FFFF
SA14	0	0	0	1	1	1	0	070000–077FFF
SA15	0	0	0	1	1	1	1	078000–07FFFF
SA16	0	0	1	0	0	0	0	080000–087FFF
SA17	0	0	1	0	0	0	1	088000–08FFFF
SA18	0	0	1	0	0	1	0	090000–097FFF
SA19	0	0	1	0	0	1	1	098000–09FFFF
SA20	0	0	1	0	1	0	0	0A0000–0A7FFF
SA21	0	0	1	0	1	0	1	0A8000–0AFFFF
SA22	0	0	1	0	1	1	0	0B0000–0B7FFF
SA23	0	0	1	0	1	1	1	0B8000–0BFFFF
SA24	0	0	1	1	0	0	0	0C0000–0C7FFF
SA25	0	0	1	1	0	0	1	0C8000–0CFFFF

Table 2. Sector Address Table (Sheet 2 of 4)

Sector	A21	A20	A19	A18	A17	A16	A15	16-bit Address Range (in hexadecimal)
SA26	0	0	1	1	0	1	0	0D0000–0D7FFF
SA27	0	0	1	1	0	1	1	0D8000–0DFFFF
SA28	0	0	1	1	1	0	0	0E0000–0E7FFF
SA29	0	0	1	1	1	0	1	0E8000–0EFFFF
SA30	0	0	1	1	1	1	0	0F0000–0F7FFF
SA31	0	0	1	1	1	1	1	0F8000–0FFFFF
SA32	0	1	0	0	0	0	0	100000–107FFF
SA33	0	1	0	0	0	0	1	108000–10FFFF
SA34	0	1	0	0	0	1	0	110000–117FFF
SA35	0	1	0	0	0	1	1	118000–11FFFF
SA36	0	1	0	0	1	0	0	120000–127FFF
SA37	0	1	0	0	1	0	1	128000–12FFFF
SA38	0	1	0	0	1	1	0	130000–137FFF
SA39	0	1	0	0	1	1	1	138000–13FFFF
SA40	0	1	0	1	0	0	0	140000–147FFF
SA41	0	1	0	1	0	0	1	148000–14FFFF
SA42	0	1	0	1	0	1	0	150000–157FFF
SA43	0	1	0	1	0	1	1	158000–15FFFF
SA44	0	1	0	1	1	0	0	160000–167FFF
SA45	0	1	0	1	1	0	1	168000–16FFFF
SA46	0	1	0	1	1	1	0	170000–177FFF
SA47	0	1	0	1	1	1	1	178000–17FFFF
SA48	0	1	1	0	0	0	0	180000–187FFF
SA49	0	1	1	0	0	0	1	188000–18FFFF
SA50	0	1	1	0	0	1	0	190000–197FFF
SA51	0	1	1	0	0	1	1	198000–19FFFF
SA52	0	1	1	0	1	0	0	1A0000–1A7FFF
SA53	0	1	1	0	1	0	1	1A8000–1AFFFF
SA54	0	1	1	0	1	1	0	1B0000–1B7FFF
SA55	0	1	1	0	1	1	1	1B8000–1BFFFF
SA56	0	1	1	1	0	0	0	1C0000–1C7FFF
SA57	0	1	1	1	0	0	1	1C8000–1CFFFF
SA58	0	1	1	1	0	1	0	1D0000–1D7FFF
SA59	0	1	1	1	0	1	1	1D8000–1DFFFF
SA60	0	1	1	1	1	0	0	1E0000–1E7FFF

Table 2. Sector Address Table (Sheet 3 of 4)

Sector	A21	A20	A19	A18	A17	A16	A15	16-bit Address Range (in hexadecimal)
SA61	0	1	1	1	1	0	1	1E8000–1EFFFF
SA62	0	1	1	1	1	1	0	1F0000–1F7FFF
SA63	0	1	1	1	1	1	1	1F8000–1FFFFFF
SA64	1	0	0	0	0	0	0	200000–207FFF
SA65	1	0	0	0	0	0	1	208000–20FFFF
SA66	1	0	0	0	0	1	0	210000–217FFF
SA67	1	0	0	0	0	1	1	218000–21FFFF
SA68	1	0	0	0	1	0	0	220000–227FFF
SA69	1	0	0	0	1	0	1	228000–22FFFF
SA70	1	0	0	0	1	1	0	230000–237FFF
SA71	1	0	0	0	1	1	1	238000–23FFFF
SA72	1	0	0	1	0	0	0	240000–247FFF
SA73	1	0	0	1	0	0	1	248000–24FFFF
SA74	1	0	0	1	0	1	0	250000–257FFF
SA75	1	0	0	1	0	1	1	258000–25FFFF
SA76	1	0	0	1	1	0	0	260000–267FFF
SA77	1	0	0	1	1	0	1	268000–26FFFF
SA78	1	0	0	1	1	1	0	270000–277FFF
SA79	1	0	0	1	1	1	1	278000–27FFFF
SA80	1	0	1	0	0	0	0	280000–287FFF
SA81	1	0	1	0	0	0	1	288000–28FFFF
SA82	1	0	1	0	0	1	0	290000–297FFF
SA83	1	0	1	0	0	1	1	298000–29FFFF
SA84	1	0	1	0	1	0	0	2A0000–2A7FFF
SA85	1	0	1	0	1	0	1	2A8000–2AFFFF
SA86	1	0	1	0	1	1	0	2B0000–2B7FFF
SA87	1	0	1	0	1	1	1	2B8000–2BFFFF
SA88	1	0	1	1	0	0	0	2C0000–2C7FFF
SA89	1	0	1	1	0	0	1	2C8000–2CFFFF
SA90	1	0	1	1	0	1	0	2D0000–2D7FFF
SA91	1	0	1	1	0	1	1	2D8000–2DFFFF
SA92	1	0	1	1	1	0	0	2E0000–2E7FFF
SA93	1	0	1	1	1	0	1	2E8000–2EFFFF
SA94	1	0	1	1	1	1	0	2F0000–2F7FFF
SA95	1	0	1	1	1	1	1	2F8000–2FFFFFF

Table 2. Sector Address Table (Sheet 4 of 4)

Sector	A21	A20	A19	A18	A17	A16	A15	16-bit Address Range (in hexadecimal)
SA96	1	1	0	0	0	0	0	300000–307FFF
SA97	1	1	0	0	0	0	1	308000–30FFFF
SA98	1	1	0	0	0	1	0	310000–317FFF
SA99	1	1	0	0	0	1	1	318000–31FFFF
SA100	1	1	0	0	1	0	0	320000–327FFF
SA101	1	1	0	0	1	0	1	328000–32FFFF
SA102	1	1	0	0	1	1	0	330000–337FFF
SA103	1	1	0	0	1	1	1	338000–33FFFF
SA104	1	1	0	1	0	0	0	340000–347FFF
SA105	1	1	0	1	0	0	1	348000–34FFFF
SA106	1	1	0	1	0	1	0	350000–357FFF
SA107	1	1	0	1	0	1	1	358000–35FFFF
SA108	1	1	0	1	1	0	0	360000–367FFF
SA109	1	1	0	1	1	0	1	368000–36FFFF
SA110	1	1	0	1	1	1	0	370000–377FFF
SA111	1	1	0	1	1	1	1	378000–37FFFF
SA112	1	1	1	0	0	0	0	380000–387FFF
SA113	1	1	1	0	0	0	1	388000–38FFFF
SA114	1	1	1	0	0	1	0	390000–397FFF
SA115	1	1	1	0	0	1	1	398000–39FFFF
SA116	1	1	1	0	1	0	0	3A0000–3A7FFF
SA117	1	1	1	0	1	0	1	3A8000–3AFFFF
SA118	1	1	1	0	1	1	0	3B0000–3B7FFF
SA119	1	1	1	0	1	1	1	3B8000–3BFFFF
SA120	1	1	1	1	0	0	0	3C0000–3C7FFF
SA121	1	1	1	1	0	0	1	3C8000–3CFFFF
SA122	1	1	1	1	0	1	0	3D0000–3D7FFF
SA123	1	1	1	1	0	1	1	3D8000–3DFFFF
SA124	1	1	1	1	1	0	0	3E0000–3E7FFF
SA125	1	1	1	1	1	0	1	3E8000–3EFFFF
SA126	1	1	1	1	1	1	0	3F0000–3F7FFF
SA127	1	1	1	1	1	1	1	3F8000–3FFFFF

Note: All sectors are 32 Kwords in size.

Autoselect Mode

The autoselect mode provides manufacturer and device identification, and sector protection verification, through identifier codes output on DQ7–DQ0. This mode is primarily intended for programming equipment to automatically match a device to be programmed with its corresponding programming algorithm. However, the autoselect codes can also be accessed in-system through the command register.

When using programming equipment, the autoselect mode requires V_{ID} (8.5 V to 12.5 V) on address pin A9. Address pins A6, A1, and A0 must be as shown in [Table 3](#). In addition, when verifying sector protection,

the sector address must appear on the appropriate highest order address bits (see [Table 2 on page 12](#)). [Table 3](#) shows the remaining address bits that are don't care. When all necessary bits are set as required, the programming equipment may then read the corresponding identifier code on DQ7–DQ0.

To access the autoselect codes in-system, the host system can issue the autoselect command via the command register, as shown in [Table 10 on page 28](#). This method does not require V_{ID} . Refer to “[Autoselect Command Sequence](#)” on [page 24](#) for more information.

Table 3. Autoselect Codes, (High Voltage Method)

Description	CE#	OE#	WE#	A21 to A15	A14 to A10	A9	A8 to A7	A6	A5 to A2	A1	A0	DQ15 to DQ0
Manufacturer ID: AMD	L	L	H	X	X	V_{ID}	X	L	X	L	L	0001h
Device ID: LV640DU/H/L, LV641DH/L	L	L	H	X	X	V_{ID}	X	L	X	L	H	22D7h
Sector Protection Verification	L	L	H	SA	X	V_{ID}	X	L	X	H	L	XX01h (protected), XX00h (unprotected)
SecSi Sector Indicator Bit (DQ7), WP# protects highest address sector (LV640DH/641DH), or no WP# (LV640DU)	L	L	H	X	X	V_{ID}	X	L	X	H	H	XX98h (factory locked), XX18h (not factory locked)
SecSi Sector Indicator Bit (DQ7), WP# protects lowest address sector (LV640DL/641DL)	L	L	H	X	X	V_{ID}	X	L	X	H	H	XX88h (factory locked), XX08h (not factory locked)

Legend: L = Logic Low = V_{IL} , H = Logic High = V_{IH} , SA = Sector Address, X = Don't care.

Sector Group Protection and Unprotection

The hardware sector group protection feature disables both program and erase operations in any sector group. In this device, a sector group consists of four adjacent sectors that are protected or unprotected at the same time (see [Table 4](#)). The hardware sector group unprotection feature re-enables both program and erase operations in previously protected sector groups. Sector group protection/unprotection is implemented via two methods.

Sector protection/unprotection requires V_{ID} on the RE-SET# pin only, and can be implemented either in-system or via programming equipment. [Figure 2, on page 19](#) shows the algorithms and [Figure 22, on page 45](#) shows the timing diagram. This method uses standard microprocessor bus cycle timing. For sector group unprotect, all unprotected sector groups must first be protected prior to the first sector group unprotect write cycle.

The device is shipped with all sector groups unprotected. AMD offers the option of programming and protecting sector groups at its factory prior to shipping the device through AMD's ExpressFlash™ Service. Contact an AMD representative for details.

It is possible to determine whether a sector group is protected or unprotected. See [“Autoselect Mode” on page 16](#) for details.

Table 4. Sector Group Protection/Unprotection Address Table

Sector Group	A21–A17
SA0–SA3	00000
SA4–SA7	00001
SA8–SA11	00010
SA12–SA15	00011
SA16–SA19	00100
SA20–SA23	00101
SA24–SA27	00110
SA28–SA31	00111
SA32–SA35	01000
SA36–SA39	01001
SA40–SA43	01010
SA44–SA47	01011
SA48–SA51	01100
SA52–SA55	01101
SA56–SA59	01110
SA60–SA63	01111
SA64–SA67	10000
SA68–SA71	10001
SA72–SA75	10010
SA76–SA79	10011
SA80–SA83	10100
SA84–SA87	10101
SA88–SA91	10110
SA92–SA95	10111
SA96–SA99	11000
SA100–SA103	11001
SA104–SA107	11010
SA108–SA111	11011
SA112–SA115	11100
SA116–SA119	11101
SA120–SA123	11110
SA124–SA127	11111

Note: All sector groups are 128 Kwords in size.

Write Protect (WP#)

The Write Protect function provides a hardware method of protecting the first or last sector without using V_{ID} .

If the system asserts V_{IL} on the WP# pin, the device disables program and erase functions in the first or last sector independently of whether those sectors were protected or unprotected using the method described in “Sector Group Protection and Unprotection”. Note that if WP# is at V_{IL} when the device is in the standby mode, the maximum input load current is increased. See the table in “DC Characteristics” on page 34.

If the system asserts V_{IH} on the WP# pin, the device reverts to whether the first or last sector was previously set to be protected or unprotected using the method described in “Sector Group Protection and Unprotection” on page 17.

Temporary Sector Group Unprotect

(Note: In this device, a sector group consists of four adjacent sectors that are protected or unprotected at the same time (see Table 4 on page 17)).

This feature allows temporary unprotection of previously protected sector groups to change data in-system. The Sector Group Unprotect mode is activated by setting the RESET# pin to V_{ID} (8.5 V – 12.5 V). During this mode, formerly protected sector groups can be programmed or erased by selecting the sector group addresses. Once V_{ID} is removed from the RESET# pin, all the previously protected sector groups are protected again. Figure 1, on page 18 shows the algorithm, and Figure 21, on page 44 shows the timing diagrams, for this feature.

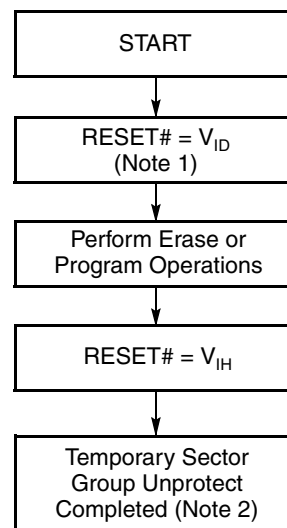

Notes:

1. All protected sector groups unprotected (If WP# = V_{IL} , the first or last sector remains protected).
2. All previously protected sector groups are protected once again.

Figure 1. Temporary Sector Group Unprotect Operation

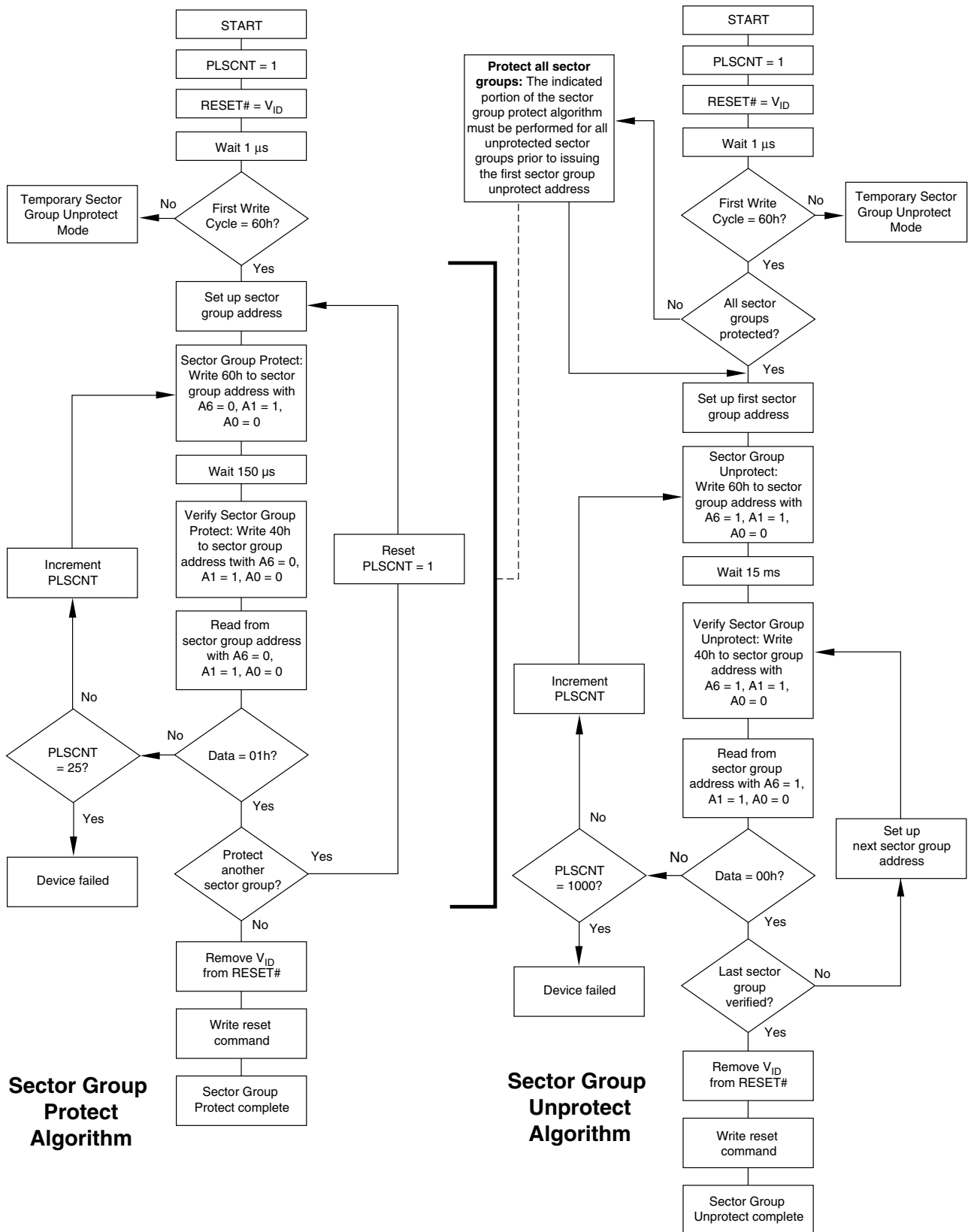

Figure 2. In-System Sector Group Protect/Unprotect Algorithms

SecSi (Secured Silicon) Sector Flash Memory Region

The SecSi (Secured Silicon) Sector feature provides a Flash memory region that enables permanent part identification through an Electronic Serial Number (ESN). The SecSi Sector is 128 words in length, and uses a SecSi Sector Indicator Bit (DQ7) to indicate whether or not the SecSi Sector is locked when shipped from the factory. This bit is permanently set at the factory and cannot be changed, which prevents cloning of a factory locked part. This ensures the security of the ESN once the product is shipped to the field.

AMD offers the device with the SecSi Sector either factory locked or customer lockable. The factory-locked version is always protected when shipped from the factory, and has the SecSi (Secured Silicon) Sector Indicator Bit permanently set to a “1.” The customer-lockable version is shipped with the SecSi Sector unprotected, allowing customers to utilize that sector in any manner they choose. The customer-lockable version also has the SecSi Sector Indicator Bit permanently set to a “0.” Thus, the SecSi Sector Indicator Bit prevents customer-lockable devices from being used to replace devices that are factory locked.

The SecSi sector address space in this device is allocated as shown in [Table 5](#):

Table 5. SecSi Sector Contents

SecSi Sector Address Range	Standard Factory Locked	ExpressFlash Factory Locked	Customer Lockable
000000h–000007h	ESN	ESN or determined by customer	Determined by customer
000008h–00007Fh	Unavailable	Determined by customer	

The system accesses the SecSi Sector through a command sequence (see [“Enter SecSi Sector/Exit SecSi Sector Command Sequence”](#) on page 24). After the system writes the Enter SecSi Sector command sequence, it may read the SecSi Sector by using the addresses normally occupied by the first sector (SA0). This mode of operation continues until the system issues the Exit SecSi Sector command sequence, or until power is removed from the device. On power-up, or following a hardware reset, the device reverts to sending commands to sector SA0.

Factory Locked: SecSi Sector Programmed and Protected At the Factory

In devices with an ESN, the SecSi Sector is protected when the device is shipped from the factory. The SecSi Sector cannot be modified in any way. A factory locked device has an 8-word random ESN at addresses 000000h–000007h.

Customers may opt to have their code programmed by AMD through the AMD ExpressFlash service. The devices are then shipped from AMD’s factory with the

SecSi Sector permanently locked. Contact an AMD representative for details on using AMD’s Express-Flash service.

Customer Lockable: SecSi Sector NOT Programmed or Protected At the Factory

As an alternative to the factory-locked version, the device can be ordered such that the customer may program and protect the 128-word SecSi sector. Programming and protecting the SecSi Sector must be used with caution since, once protected, there is no procedure available for unprotecting the SecSi Sector area and none of the bits in the SecSi Sector memory space can be modified in any way.

You can protect the SecSi Sector area using one of the following procedures:

- Write the three-cycle Enter SecSi Sector Region command sequence, and then follow the in-system sector protect algorithm as shown in [Figure 2](#), on page 19, except that *RESET#* may be at either V_{IH} or V_{ID} . This allows in-system protection of the SecSi Sector without raising any device pin to a high voltage. Note that this method is only applicable to the SecSi Sector.
- Write the three-cycle Enter SecSi Sector Region command sequence, then use the alternate method of sector protection described in the [“Sector Group Protection and Unprotection”](#) on page 17.

Once the SecSi Sector is programmed, locked, and verified, the system must write the Exit SecSi Sector Region command sequence to return to reading and writing within the remainder of the array.

Hardware Data Protection

The command sequence requirement of unlock cycles for programming or erasing provides data protection against inadvertent writes (refer to [Table 10](#) on page 28 for command definitions). In addition, the following hardware data protection measures prevent accidental erasure or programming, which might otherwise be caused by spurious system level signals during V_{CC} power-up and power-down transitions, or from system noise.

Low V_{CC} Write Inhibit

When V_{CC} is less than V_{LKO} , the device does not accept any write cycles. This protects data during V_{CC} power-up and power-down. The command register and all internal program/erase circuits are disabled, and the device resets to the read mode. Subsequent writes are ignored until V_{CC} is greater than V_{LKO} . The system must provide the proper signals to the control pins to prevent unintentional writes when V_{CC} is greater than V_{LKO} .

Write Pulse “Glitch” Protection

Noise pulses of less than 5 ns (typical) on OE#, CE# or WE#, do not initiate a write cycle.

Logical Inhibit

Write cycles are inhibited by holding any one of OE# = V_{IL} , CE# = V_{IH} or WE# = V_{IH} . To initiate a write cycle,

CE# and WE# must be a logical zero while OE# is a logical one.

Power-Up Write Inhibit

If WE# = CE# = V_{IL} and OE# = V_{IH} during power up, the device does not accept commands on the rising edge of WE#. The internal state machine is automatically reset to the read mode on power-up.

COMMON FLASH MEMORY INTERFACE (CFI)

The Common Flash Interface (CFI) specification outlines device and host system software interrogation handshake, which allows specific vendor-specified software algorithms to be used for entire families of devices. Software support can then be device-independent, JEDEC ID-independent, and forward-and backward-compatible for the specified flash device families. Flash vendors can standardize their existing interfaces for long-term compatibility.

This device enters the CFI Query mode when the system writes the CFI Query command, 98h, to address 55h, any time the device is ready to read array data. The system reads CFI information at the addresses given in [Table 6 on page 21](#) to [Table 9 on page 23](#). To

terminate reading CFI data, the system must write the reset command.

The system can also write the CFI query command when the device is in the autoselect mode. The device enters the CFI query mode, and the system can read CFI data at the addresses given in [Table 6 on page 21](#) to [Table 9 on page 23](#). The system must write the reset command to return the device to the autoselect mode.

For further information, please refer to the CFI Specification and CFI Publication 100, available via the World Wide Web at <http://www.amd.com/products/nvd/overview/cfi.html>. Alternatively, contact an AMD representative for copies of these documents.

Table 6. CFI Query Identification String

Addresses (x16)	Data	Description
10h 11h 12h	0051h 0052h 0059h	Query Unique ASCII string “QRY”
13h 14h	0002h 0000h	Primary OEM Command Set
15h 16h	0040h 0000h	Address for Primary Extended Table
17h 18h	0000h 0000h	Alternate OEM Command Set (00h = none exists)
19h 1Ah	0000h 0000h	Address for Alternate OEM Extended Table (00h = none exists)

Table 7. System Interface String

Addresses (x16)	Data	Description
1Bh	0027h	V _{CC} Min. (write/erase) D7–D4: volt, D3–D0: 100 millivolt
1Ch	0036h	V _{CC} Max. (write/erase) D7–D4: volt, D3–D0: 100 millivolt
1Dh	0000h	V _{PP} Min. voltage (00h = no V _{PP} pin present)
1Eh	0000h	V _{PP} Max. voltage (00h = no V _{PP} pin present)
1Fh	0004h	Typical timeout per single word write 2 ^N μs
20h	0000h	Typical timeout for Min. size buffer write 2 ^N μs (00h = not supported)
21h	000Ah	Typical timeout per individual block erase 2 ^N ms
22h	0000h	Typical timeout for full chip erase 2 ^N ms (00h = not supported)
23h	0005h	Max. timeout for word write 2 ^N times typical
24h	0000h	Max. timeout for buffer write 2 ^N times typical
25h	0004h	Max. timeout per individual block erase 2 ^N times typical
26h	0000h	Max. timeout for full chip erase 2 ^N times typical (00h = not supported)

Table 8. Device Geometry Definition

Addresses (x16)	Data	Description
27h	0017h	Device Size = 2 ^N byte
28h 29h	0001h 0000h	Flash Device Interface description (refer to CFI publication 100)
2Ah 2Bh	0000h 0000h	Max. number of byte in multi-byte write = 2 ^N (00h = not supported)
2Ch	0001h	Number of Erase Block Regions within device
2Dh 2Eh 2Fh 30h	007Fh 0000h 0000h 0001h	Erase Block Region 1 Information (refer to the CFI specification or CFI publication 100)
31h 32h 33h 34h	0000h 0000h 0000h 0000h	Erase Block Region 2 Information (refer to CFI publication 100)
35h 36h 37h 38h	0000h 0000h 0000h 0000h	Erase Block Region 3 Information (refer to CFI publication 100)
39h 3Ah 3Bh 3Ch	0000h 0000h 0000h 0000h	Erase Block Region 4 Information (refer to CFI publication 100)

Table 9. Primary Vendor-Specific Extended Query

Addresses (x16)	Data	Description
40h 41h 42h	0050h 0052h 0049h	Query-unique ASCII string "PRI"
43h	0031h	Major version number, ASCII
44h	0033h	Minor version number, ASCII
45h	0000h	Address Sensitive Unlock (Bits 1-0) 00b = Required, 01b = Not Required Silicon Revision Number (Bits 7-2) 000000b = 0.23 μ m Process Technology
46h	0002h	Erase Suspend 00 = Not Supported, 01 = To Read Only, 02 = To Read & Write
47h	0004h	Sector Protect 00 = Not Supported, X = Number of sectors per group
48h	0001h	Sector Temporary Unprotect 00 = Not Supported, 01 = Supported
49h	0004h	Sector Protect/Unprotect scheme 04 = 29LV800A mode
4Ah	0000h	Simultaneous Operation 00 = Not Supported, XX = Number of Sectors in Bank
4Bh	0000h	Burst Mode Type 00 = Not Supported, 01 = Supported
4Ch	0000h	Page Mode Type 00 = Not Supported, 01 = 4 Word Page, 02 = 8 Word Page
4Dh	00B5h	ACC (Acceleration) Supply Minimum Bits 7–4 = Hex Value in Volts, Bits 0–3 = BCD Value in 100 mV
4Eh	00C5h	ACC (Acceleration) Supply Maximum Bits 7–4 = Hex Value in Volts, Bits 0–3 = BCD Value in 100 mV
4Fh	000Xh	Top/Bottom Boot Sector Flag 00h = Uniform Sector, No WP# Control 04h = Uniform Sector, WP# Protects Bottom Sector 05h = Uniform Sector, WP# Protects Top Sector

COMMAND DEFINITIONS

Writing specific address and data commands or sequences into the command register initiates device operations. [Table 10 on page 28](#) defines the valid register command sequences. Writing **incorrect address and data values** or writing them in the **improper sequence**, resets the device to reading array data.

All addresses are latched on the falling edge of WE# or CE#, whichever happens later. All data is latched on the rising edge of WE# or CE#, whichever happens first. Refer to ["AC Characteristics" on page 37](#) for timing diagrams.

Reading Array Data

The device is automatically set to reading array data after device power-up. No commands are required to retrieve data. The device is ready to read array data after completing an Embedded Program or Embedded Erase algorithm.

After the device accepts an Erase Suspend command, the device enters the erase-suspend-read mode, after which the system can read data from any non-erase-suspended sector. After completing a programming operation in the Erase Suspend mode, the system may once again read array data with the same exception. See ["Erase Suspend/Erase Resume Commands" on page 26](#), for more information.

The system *must* issue the reset command to return the device to the read (or erase-suspend-read) mode if DQ5 goes high during an active program or erase operation, or if the device is in the autoselect mode. See the next section, [Reset Command](#), for more information.

See also [“Requirements for Reading Array Data” on page 10](#) in the [Device Bus Operations](#) section for more information. The [“Read-Only Operations” on page 37](#) table provides the read parameters, and [Figure 13, on page 37](#) shows the timing diagram.

Reset Command

Writing the reset command resets the device to the read or erase-suspend-read mode. Address bits are don't cares for this command.

The reset command may be written between the sequence cycles in an erase command sequence before erasing begins. This resets the device to the read mode. Once erasure begins, however, the device ignores reset commands until the operation is complete.

The reset command may be written between the sequence cycles in a program command sequence before programming begins. This resets the device to the read mode. If the program command sequence is written while the device is in the Erase Suspend mode, writing the reset command returns the device to the erase-suspend-read mode. Once programming begins, however, the device ignores reset commands until the operation is complete.

The reset command may be written between the sequence cycles in an autoselect command sequence. Once in the autoselect mode, the reset command must be written to return to the read mode. If the device entered the autoselect mode while in the Erase Suspend mode, writing the reset command returns the device to the erase-suspend-read mode.

If DQ5 goes high during a program or erase operation, writing the reset command returns the device to the read mode (or erase-suspend-read mode if the device was in Erase Suspend).

Autoselect Command Sequence

The autoselect command sequence allows the host system to access the manufacturer and device codes, and determine whether or not a sector is protected. [Table 10 on page 28](#) shows the address and data requirements. This method is an alternative to that shown in [Table 3 on page 16](#), which is intended for PROM programmers and requires V_{ID} on address pin A9. The autoselect command sequence may be written to an address that is either in the read or erase-suspend-read mode. The autoselect command cannot be written while the device is actively programming or erasing.

The autoselect command sequence is initiated by first writing two unlock cycles. This is followed by a third write cycle that contains the autoselect command. The device then enters the autoselect mode. The system may read at any address any number of times without initiating another autoselect command sequence:

- A read cycle at address XX00h returns the manufacturer code.
- A read cycle at address XX01h returns the device code.
- A read cycle to an address containing a sector group address (SA), and the address 02h on A7–A0 returns 01h if the sector group is protected, or 00h if it is unprotected. (Refer to [Table 4 on page 17](#) for valid sector addresses).

The system must write the reset command to return to the read mode (or erase-suspend-read mode if the device was previously in Erase Suspend).

Enter SecSi Sector/Exit SecSi Sector Command Sequence

The SecSi Sector region provides a secured data area containing an 8-word random Electronic Serial Number (ESN). The system can access the SecSi Sector region by issuing the three-cycle Enter SecSi Sector command sequence. The device continues to access the SecSi Sector region until the system issues the four-cycle Exit SecSi Sector command sequence. The Exit SecSi Sector command sequence returns the device to normal operation. [Table 10 on page 28](#) shows the address and data requirements for both command sequences. See also [“SecSi \(Secured Silicon\) Sector Flash Memory Region” on page 20](#) for further information.

Word Program Command Sequence

Programming is a four-bus-cycle operation. The program command sequence is initiated by writing two unlock write cycles, followed by the program set-up command. The program address and data are written next, which in turn initiate the Embedded Program algorithm. The system is *not* required to provide further controls or timings. The device automatically provides internally generated program pulses and verifies the programmed cell margin. The [“Command Definitions” on page 28](#) shows the address and data requirements for the word program command sequence.

When the Embedded Program algorithm is complete, the device returns to the read mode and addresses are no longer latched. The system determines the status of the program operation by using DQ7, DQ6, or RY/BY#. Refer to [“Write Operation Status” on page 29](#) for information on these status bits.

Any commands written to the device during the Embedded Program Algorithm are ignored. Note that a **hardware reset** immediately terminates the program operation. The program command sequence should be reinitiated once the device returns to the read mode, to ensure data integrity.

Programming is allowed in any sequence and across sector boundaries. **A bit cannot be programmed from “0” back to a “1.”** Attempting to do so may cause the device to set DQ5 = 1, or cause the DQ7 and DQ6 status bits to indicate the operation was successful. However, a succeeding read shows that the data is still “0.” Only erase operations can convert a “0” to a “1.”

Unlock Bypass Command Sequence

The unlock bypass feature allows the system to program words to the device faster than using the standard program command sequence. The unlock bypass command sequence is initiated by first writing two unlock cycles. This is followed by a third write cycle containing the unlock bypass command, 20h. The device then enters the unlock bypass mode. A two-cycle unlock bypass program command sequence is all that is required to program in this mode. The first cycle in this sequence contains the unlock bypass program command, A0h; the second cycle contains the program address and data. Additional data is programmed in the same manner. This mode dispenses with the initial two unlock cycles required in the standard program command sequence, resulting in faster total programming time. [Table 10 on page 28](#) shows the requirements for the command sequence.

During the unlock bypass mode, only the Unlock Bypass Program and Unlock Bypass Reset commands are valid. To exit the unlock bypass mode, the system must issue the two-cycle unlock bypass reset command sequence. The first cycle must contain the data 90h. The second cycle must contain the data 00h. The device then returns to the read mode.

The device offers accelerated program operations through the ACC pin. When the system asserts V_{HH} on the ACC pin, the device automatically enters the Unlock Bypass mode. The system may then write the two-cycle Unlock Bypass program command sequence. The device uses the higher voltage on the ACC pin to accelerate the operation. *Note that the ACC pin must not be at V_{HH} for operations other than accelerated programming, or device damage may result.*

[Figure 3](#) illustrates the algorithm for the program operation. Refer to the [“Erase and Program Operations”](#) on

[page 39](#) table in the AC Characteristics section for parameters, and [Figure 15, on page 40](#) for timing diagrams.

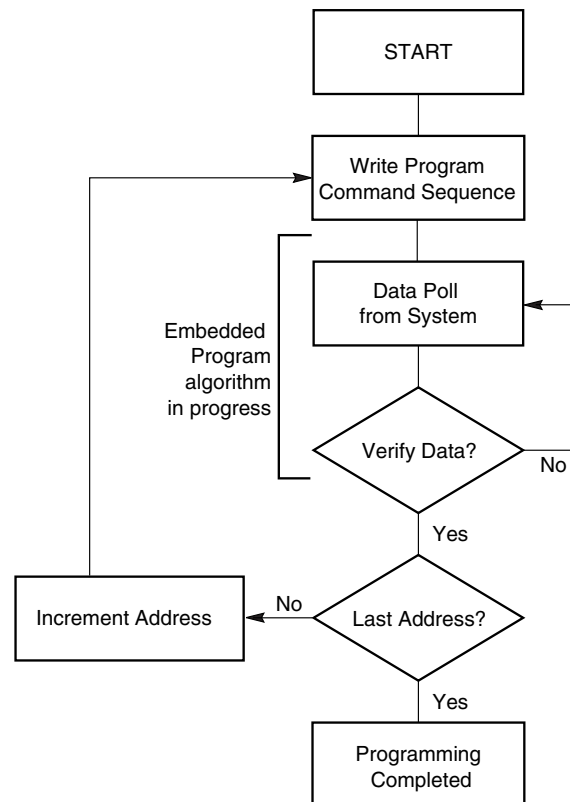

Note: See [Table 10 on page 28](#), for program command sequence.

Figure 3. Program Operation

Chip Erase Command Sequence

Chip erase is a six bus cycle operation. The chip erase command sequence is initiated by writing two unlock cycles, followed by a set-up command. Two additional unlock write cycles are then followed by the chip erase command, which in turn invokes the Embedded Erase algorithm. The device does *not* require the system to preprogram prior to erase. The Embedded Erase algorithm automatically preprograms and verifies the entire memory for an all zero data pattern prior to electrical erase. The system is not required to provide any controls or timings during these operations. [Table 10 on page 28](#) shows the address and data requirements for the chip erase command sequence.

When the Embedded Erase algorithm is complete, the device returns to the read mode and addresses are no longer latched. The system can determine the status of the erase operation by using DQ7, DQ6, DQ2, or RY/BY#. Refer to [“Write Operation Status” on page 29](#) for information on these status bits.

Any commands written during the chip erase operation are ignored. However, note that a **hardware reset** immediately terminates the erase operation. If that occurs, the chip erase command sequence should be reinitiated once the device has returned to reading array data, to ensure data integrity.

[Figure 4, on page 27](#) illustrates the algorithm for the erase operation. Refer to the table [“Erase and Program Operations” on page 39](#) in the AC Characteristics section for parameters, and [Figure 17, on page 41](#) for timing diagrams.

Sector Erase Command Sequence

Sector erase is a six bus cycle operation. The sector erase command sequence is initiated by writing two unlock cycles, followed by a set-up command. Two additional unlock cycles are written, and are then followed by the address of the sector to be erased, and the sector erase command. [Table 10 on page 28](#) shows the address and data requirements for the sector erase command sequence.

The device does *not* require the system to preprogram prior to erase. The Embedded Erase algorithm automatically programs and verifies the entire memory for an all zero data pattern prior to electrical erase. The system is not required to provide any controls or timings during these operations.

After the command sequence is written, a sector erase time-out of 50 μ s occurs. During the time-out period, additional sector addresses and sector erase commands may be written. Loading the sector erase buffer may be done in any sequence, and the number of sectors may be from one sector to all sectors. The time between these additional cycles must be less than 50 μ s, otherwise erasure may begin. Any sector erase address and command following the exceeded time-out may or may not be accepted. It is recommended that processor interrupts be disabled during this time to ensure all commands are accepted. The interrupts can be re-enabled after the last Sector Erase command is written. **Any command other than Sector Erase or Erase Suspend during the time-out period resets the device to the read mode.** The system must re-write the command sequence and any additional addresses and commands.

The system can monitor DQ3 to determine if the sector erase timer has timed out (See the section [“DQ3: Sector Erase Timer” on page 31](#)). The time-out be-

gins from the rising edge of the final WE# pulse in the command sequence.

When the Embedded Erase algorithm is complete, the device returns to reading array data and addresses are no longer latched. The system can determine the status of the erase operation by reading DQ7, DQ6, DQ2, or RY/BY#. Refer to [“Write Operation Status” on page 29](#) for information on these status bits.

Once the sector erase operation has begun, only the Erase Suspend command is valid. All other commands are ignored. However, note that a **hardware reset** immediately terminates the erase operation. If that occurs, the sector erase command sequence should be reinitiated once the device returns to reading array data, to ensure data integrity.

[Figure 4, on page 27](#) illustrates the algorithm for the erase operation. Refer to the table [“Erase and Program Operations” on page 39](#) in the AC Characteristics section for parameters, and [Figure 17, on page 41](#) for timing diagrams.

Erase Suspend/Erase Resume Commands

The Erase Suspend command, B0h, allows the system to interrupt a sector erase operation and then read data from, or program data to, any sector not selected for erasure. This command is valid only during the sector erase operation, including the 50 μ s time-out period during the sector erase command sequence. The Erase Suspend command is ignored if written during the chip erase operation or Embedded Program algorithm.

When the Erase Suspend command is written during the sector erase operation, the device requires a maximum of 20 μ s to suspend the erase operation. However, when the Erase Suspend command is written during the sector erase time-out, the device immediately terminates the time-out period and suspends the erase operation.

After the erase operation is suspended, the device enters the erase-suspend-read mode. The system can read data from or program data to any sector not selected for erasure. (The device “erase suspends” all sectors selected for erasure.) Reading at any address within erase-suspended sectors produces status information on DQ7–DQ0. The system can use DQ7, or DQ6 and DQ2 together, to determine if a sector is actively erasing or is erase-suspended. Refer to [“Write Operation Status” on page 29](#) for information on these status bits.

After an erase-suspended program operation is complete, the device returns to the erase-suspend-read mode. The system determines the status of the program operation using the DQ7 or DQ6 status bits, just

as in the standard word program operation. Refer to “Write Operation Status” on page 29 for more information.

In the erase-suspend-read mode, the system can also issue the autoselect command sequence. Refer to “Autoselect Mode” on page 16 and “Autoselect Command Sequence” on page 24 for details.

To resume the sector erase operation, the system must write the Erase Resume command. Further writes of the Resume command are ignored. Another Erase Suspend command can be written after the chip resumes erasing.

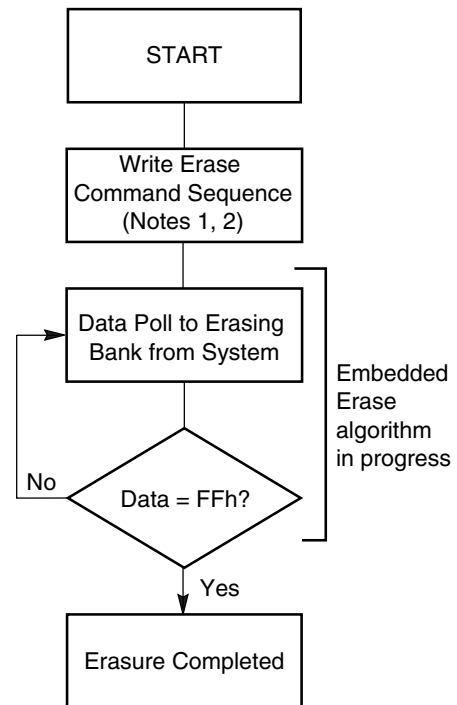

Notes:

1. See [Table 10](#) for erase command sequence.
2. See the section on DQ3 for information on the sector erase timer.

Figure 4. Erase Operation

Command Definitions

Table 10. Command Definitions

Command Sequence	Cycles	Bus Cycles (Notes 1–4)												
		First		Second		Third		Fourth		Fifth		Sixth		
		Addr	Data	Addr	Data	Addr	Data	Addr	Data	Addr	Data	Addr	Data	
Read (Note 5)	1	RA	RD											
Reset (Note 6)	1	XXX	F0											
Autoselect (Note 7)	Manufacturer ID	4	555	AA	2AA	55	555	90	X00	0001				
	Device ID	4	555	AA	2AA	55	555	90	X01	22D7				
	SecSi™ Sector Factory Protect (Note 8)	6	555	AA	2AA	55	555	88	X02	60	X02	40	X02	see (Note 9)
	Sector Group Protect Verify (Note 9)	4	555	AA	2AA	55	555	90	(SA)X02	XX00/ XX01				
Enter SecSi Sector Region	3	555	AA	2AA	55	555	88							
Exit SecSi Sector Region	4	555	AA	2AA	55	555	90	XXX	00					
Program	4	555	AA	2AA	55	555	A0	PA	PD					
Unlock Bypass	3	555	AA	2AA	55	555	20							
Unlock Bypass Program (Note 10)	2	XXX	A0	PA	PD									
Unlock Bypass Reset (Note 11)	2	XXX	90	XXX	00									
Chip Erase	6	555	AA	2AA	55	555	80	555	AA	2AA	55	555	10	
Sector Erase	6	555	AA	2AA	55	555	80	555	AA	2AA	55	SA	30	
Erase Suspend (Note 12)	1	XXX	B0											
Erase Resume (Note 13)	1	XXX	30											
CFI Query (Note 14)	1	55	98											

Legend:

X = Don't care

RA = Address of the memory location to be read.

RD = Data read from location RA during read operation.

PA = Address of the memory location to be programmed. Addresses latch on the falling edge of the WE# or CE# pulse, whichever happens later.

PD = Data to be programmed at location PA. Data latches on the rising edge of WE# or CE# pulse, whichever happens first.

SA = Address of the sector to be verified (in autoselect mode) or erased. Address bits A21–A15 uniquely select any sector.

Notes:

- See Table 1 on page 10 for a description of bus operations.
- All values are in hexadecimal.
- Except for the read cycle and the fourth cycle of the autoselect command sequence, all bus cycles are write cycles.
- During unlock cycles, (when lower address bits are 555 or 2AAh as shown in table) address bits higher than A11 (except where BA is required) and data bits higher than DQ7 are don't cares.
- No unlock or command cycles required when device is in read mode.
- The Reset command is required to return to the read mode (or to the erase-suspend-read mode if previously in Erase Suspend) when the device is in the autoselect mode, or if DQ5 goes high (while the device is providing status information).
- The fourth cycle of the autoselect command sequence is a read cycle. Data bits DQ15–DQ8 are don't care. See the "Autoselect Command Sequence" on page 24 section for more information.
- If WP# protects the highest address sector (or if WP# is not available), the data is 98h for factory locked and 18h for not factory locked. If WP# protects the lowest address sector, the data is 88h for factory locked and 08h for not factor locked.
- The data is 00h for an unprotected sector group and 01h for a protected sector group.
- The Unlock Bypass command is required prior to the Unlock Bypass Program command.
- The Unlock Bypass Reset command is required to return to the read mode when the device is in the unlock bypass mode.
- The system may read and program in non-erasing sectors, or enter the autoselect mode, when in the Erase Suspend mode. The Erase Suspend command is valid only during a sector erase operation.
- The Erase Resume command is valid only during the Erase Suspend mode.
- Command is valid when device is ready to read array data or when device is in autoselect mode.

WRITE OPERATION STATUS

The device provides several bits to determine the status of a program or erase operation: DQ2, DQ3, DQ5, DQ6, and DQ7. Table 11 on page 32 and the following subsections describe the function of these bits. DQ7 and DQ6 each offer a method for determining whether a program or erase operation is complete or in progress. The device also provides a hardware-based output signal, RY/BY#, to determine whether an Embedded Program or Erase operation is in progress or was completed.

DQ7: Data# Polling

The Data# Polling bit, DQ7, indicates to the host system whether an Embedded Program or Erase algorithm is in progress or completed, or whether the device is in Erase Suspend. Data# Polling is valid after the rising edge of the final WE# pulse in the command sequence.

During the Embedded Program algorithm, the device outputs on DQ7 the complement of the datum programmed to DQ7. This DQ7 status also applies to programming during Erase Suspend. When the Embedded Program algorithm is complete, the device outputs the datum programmed to DQ7. The system must provide the program address to read valid status information on DQ7. If a program address falls within a protected sector, Data# Polling on DQ7 is active for approximately 1 μ s, at that time the device returns to the read mode.

During the Embedded Erase algorithm, Data# Polling produces a “0” on DQ7. When the Embedded Erase algorithm is complete, or if the device enters the Erase Suspend mode, Data# Polling produces a “1” on DQ7. The system must provide an address within any of the sectors selected for erasure to read valid status information on DQ7.

After an erase command sequence is written, if all sectors selected for erasing are protected, Data# Polling on DQ7 is active for approximately 100 μ s, then the device returns to the read mode. If not all selected sectors are protected, the Embedded Erase algorithm erases the unprotected sectors, and ignores the selected sectors that are protected. However, if the system reads DQ7 at an address within a protected sector, the status may not be valid.

Just prior to the completion of an Embedded Program or Erase operation, DQ7 may change asynchronously with DQ0–DQ6 while Output Enable (OE#) is asserted low. That is, the device may change from providing status information to valid data on DQ7. Depending on when the system samples the DQ7 output, it may read the status or valid data. Even if the device has completed the program or erase operation and DQ7 has valid data, the data outputs on DQ0–DQ6 may be still

invalid. Valid data on DQ0–DQ7 appears on successive read cycles.

Table 11 on page 32 shows the outputs for Data# Polling on DQ7. Figure 5, on page 29 shows the Data# Polling algorithm. Figure 18, on page 42 in the AC Characteristics section shows the Data# Polling timing diagram.

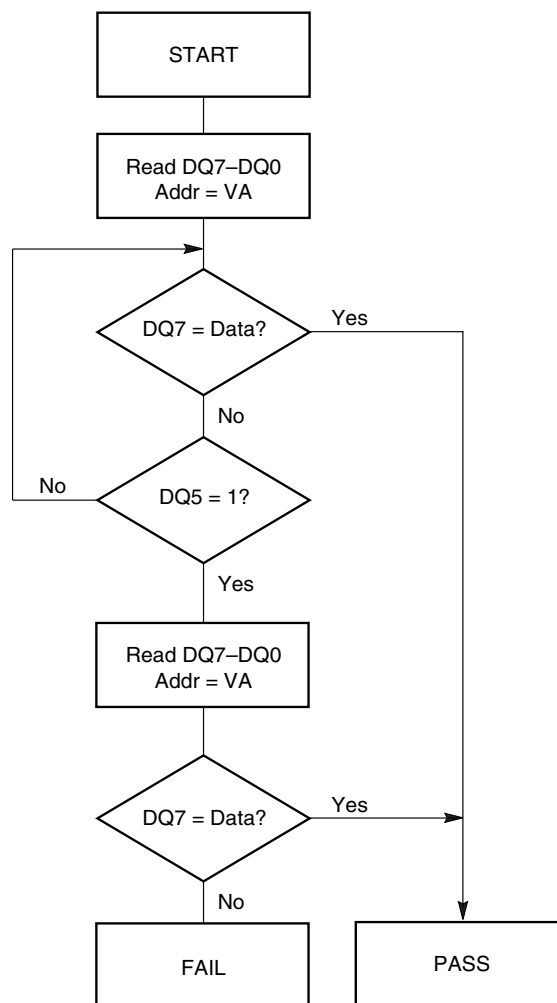

Notes:

1. VA = Valid address for programming. During a sector erase operation, a valid address is any sector address within the sector being erased. During chip erase, a valid address is any non-protected sector address.
2. DQ7 should be rechecked even if DQ5 = “1” because DQ7 may change simultaneously with DQ5.

Figure 5. Data# Polling Algorithm

R_Y/B_Y#: Ready/Busy#

The R_Y/B_Y# is a dedicated, open-drain output pin which indicates whether an Embedded Algorithm is in progress or complete. The R_Y/B_Y# status is valid after the rising edge of the final WE# pulse in the command sequence. Since R_Y/B_Y# is an open-drain output, several R_Y/B_Y# pins can be tied together in parallel with a pull-up resistor to V_{CC}.

If the output is low (Busy), the device is actively erasing or programming. (This includes programming in the Erase Suspend mode.) If the output is high (Ready), the device is in the read mode, the standby mode, or the device is in the erase-suspend-read mode.

Table 11 on page 32 shows the outputs for R_Y/B_Y#.

DQ6: Toggle Bit I

Toggle Bit I on DQ6 indicates whether an Embedded Program or Erase algorithm is in progress or complete, or whether the device has entered the Erase Suspend mode. Toggle Bit I may be read at any address, and is valid after the rising edge of the final WE# pulse in the command sequence (prior to the program or erase operation), and during the sector erase time-out.

During an Embedded Program or Erase algorithm operation, successive read cycles to any address cause DQ6 to toggle. The system may use either OE# or CE# to control the read cycles. When the operation is complete, DQ6 stops toggling.

After an erase command sequence is written, if all sectors selected for erasing are protected, DQ6 toggles for approximately 100 μs, then returns to reading array data. If not all selected sectors are protected, the Embedded Erase algorithm erases the unprotected sectors, and ignores the selected sectors that are protected.

The system can use DQ6 and DQ2 together to determine whether a sector is actively erasing or is erase-suspended. When the device is actively erasing (that is, the Embedded Erase algorithm is in progress), DQ6 toggles. When the device enters the Erase Suspend mode, DQ6 stops toggling. However, the system must also use DQ2 to determine which sectors are erasing or erase-suspended. Alternatively, the system can use DQ7 (see the subsection “DQ7: Data# Polling” on page 29).

If a program address falls within a protected sector, DQ6 toggles for approximately 1 μs after the program command sequence is written, then returns to reading array data.

DQ6 also toggles during the erase-suspend-program mode, and stops toggling once the Embedded Program algorithm is complete.

Table 11 on page 32 shows the outputs for Toggle Bit I on DQ6. Figure 6, on page 30 shows the toggle bit algorithm. Figure 19, on page 43 in the “AC Characteristics” section shows the toggle bit timing diagrams. Figure 20, on page 43 shows the differences between DQ2 and DQ6 in graphical form. See also the subsection “DQ2: Toggle Bit II” on page 31.

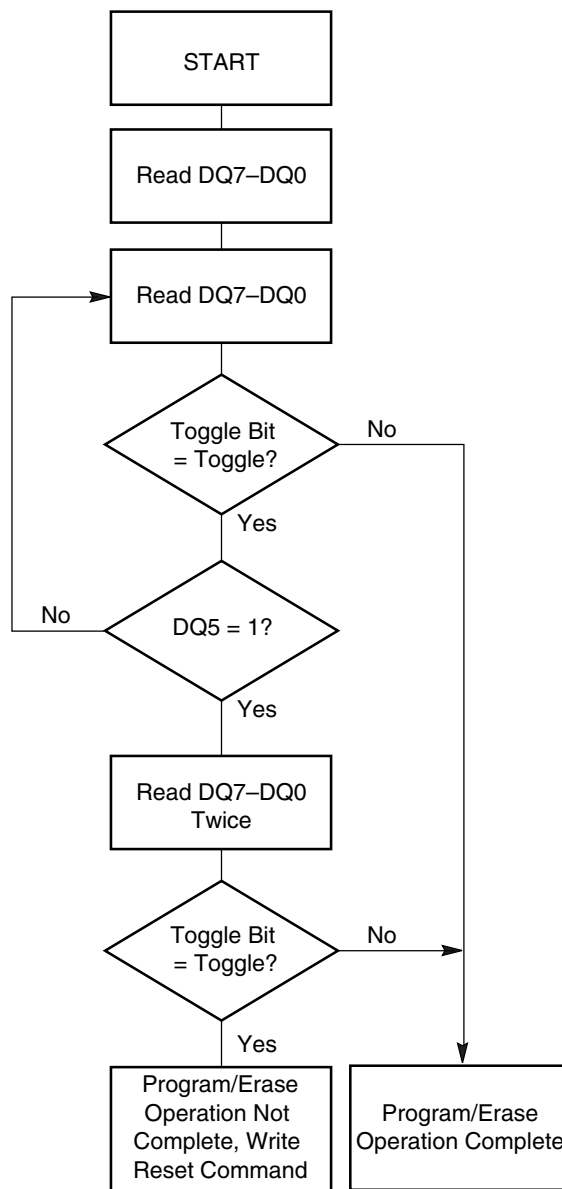

Note: The system should recheck the toggle bit even if DQ5 = “1” because the toggle bit may stop toggling as DQ5 changes to “1.” See the subsections on DQ6 and DQ2 for more information.

Figure 6. Toggle Bit Algorithm

DQ2: Toggle Bit II

The “Toggle Bit II” on DQ2, when used with DQ6, indicates whether a particular sector is actively erasing (that is, the Embedded Erase algorithm is in progress), or whether that sector is erase-suspended. Toggle Bit II is valid after the rising edge of the final WE# pulse in the command sequence.

DQ2 toggles when the system reads at addresses within those sectors that were selected for erasure. (The system may use either OE# or CE# to control the read cycles.) But DQ2 cannot distinguish whether the sector is actively erasing or is erase-suspended. DQ6, by comparison, indicates whether the device is actively erasing, or is in Erase Suspend, but cannot distinguish which sectors are selected for erasure. Thus, both status bits are required for sector and mode information. Refer to [Table 11 on page 32](#) to compare outputs for DQ2 and DQ6.

[Figure 6, on page 30](#) shows the toggle bit algorithm in flowchart form, and the section “DQ2: Toggle Bit II” explains the algorithm. See also the “[DQ6: Toggle Bit I](#)” on [page 30](#) subsection. [Figure 19, on page 43](#) shows the toggle bit timing diagram. [Figure 20, on page 43](#) shows the differences between DQ2 and DQ6 in graphical form.

Reading Toggle Bits DQ6/DQ2

Refer to [Figure 6, on page 30](#) for the following discussion. Whenever the system initially begins reading toggle bit status, it must read DQ7–DQ0 at least twice in a row to determine whether a toggle bit is toggling. Typically, the system would note and store the value of the toggle bit after the first read. After the second read, the system would compare the new value of the toggle bit with the first. If the toggle bit is not toggling, the device has completed the program or erase operation. The system can read array data on DQ7–DQ0 on the following read cycle.

However, if after the initial two read cycles, the system determines that the toggle bit is still toggling, the system also should note whether the value of DQ5 is high (see the sub-section on DQ5). If it is, the system should then determine again whether the toggle bit is toggling, since the toggle bit may have stopped toggling just as DQ5 went high. If the toggle bit is no longer toggling, the device has successfully completed the program or erase operation. If it is still toggling, the device did not complete the operation successfully, and the system must write the reset command to return to reading array data.

The remaining scenario is that the system initially determines that the toggle bit is toggling and DQ5 has not gone high. The system may continue to monitor

the toggle bit and DQ5 through successive read cycles, determining the status as described in the previous paragraph. Alternatively, it may choose to perform other system tasks. In this case, the system must start at the beginning of the algorithm when it returns to determine the status of the operation (top of [Figure 6, on page 30](#)).

DQ5: Exceeded Timing Limits

DQ5 indicates whether the program or erase time has exceeded a specified internal pulse count limit. Under these conditions DQ5 produces a “1,” indicating that the program or erase cycle was not successfully completed.

The device may output a “1” on DQ5 if the system tries to program a “1” to a location that was previously programmed to “0.” **Only an erase operation can change a “0” back to a “1.”** Under this condition, the device halts the operation, and when the timing limit is exceeded, DQ5 produces a “1.”

Under both these conditions, the system must write the reset command to return to the read mode (or to the erase-suspend-read mode if the device was previously in the erase-suspend-program mode).

DQ3: Sector Erase Timer

After writing a sector erase command sequence, the system may read DQ3 to determine whether or not erasure has begun. (The sector erase timer does not apply to the chip erase command.) If additional sectors are selected for erasure, the entire time-out also applies after each additional sector erase command. When the time-out period is complete, DQ3 switches from a “0” to a “1.” If the time between additional sector erase commands from the system can be assumed to be less than 50 μ s, the system need not monitor DQ3. See also “[Sector Erase Command Sequence](#)” on [page 26](#).

After the sector erase command is written, the system should read the status of DQ7 (Data# Polling) or DQ6 (Toggle Bit I) to ensure that the device has accepted the command sequence, and then read DQ3. If DQ3 is “1,” the Embedded Erase algorithm has begun; all further commands (except Erase Suspend) are ignored until the erase operation is complete. If DQ3 is “0,” the device accepts additional sector erase commands. To ensure the command was accepted, the system software should check the status of DQ3 prior to and following each subsequent sector erase command. If DQ3 is high on the second status check, the last command might not have been accepted.

[Table 11 on page 32](#) shows the status of DQ3 relative to the other status bits.

Table 11. Write Operation Status

Status		DQ7 (Note 2)	DQ6	DQ5 (Note 1)	DQ3	DQ2 (Note 2)	RY/BY# (Note 3)	
Standard Mode	Embedded Program Algorithm	DQ7#	Toggle	0	N/A	No toggle	0	
	Embedded Erase Algorithm	0	Toggle	0	1	Toggle	0	
Erase Suspend Mode	Erase-Suspend-Read	Erase Suspended Sector	1	No toggle	0	N/A	Toggle	1
		Non-Erase Suspended Sector	Data	Data	Data	Data	Data	1
	Erase-Suspend-Program	DQ7#	Toggle	0	N/A	N/A	0	

Notes:

1. DQ5 switches to '1' when an Embedded Program or Embedded Erase operation has exceeded the maximum timing limits. Refer to the section on DQ5 for more information.
2. DQ7 and DQ2 require a valid address when reading status information. Refer to the appropriate subsection for further details.
3. RY/BY# is only available on the FBGA package.

ABSOLUTE MAXIMUM RATINGS

Storage Temperature

Plastic Packages -65°C to $+150^{\circ}\text{C}$

Ambient Temperature

with Power Applied -65°C to $+125^{\circ}\text{C}$

Voltage with Respect to Ground

V_{CC} (Note 1) -0.5 V to $+4.0\text{ V}$

V_{IO} -0.5 V to $+5.5\text{ V}$

A9, OE#, ACC, and RESET#

(Note 2) -0.5 V to $+12.5\text{ V}$

All other pins (Note 1) -0.5 V to $V_{\text{CC}}+0.5\text{ V}$

Output Short Circuit Current (Note 3) 200 mA

Notes:

1. Minimum DC voltage on input or I/O pins is -0.5 V . During voltage transitions, input or I/O pins may overshoot V_{SS} to -2.0 V for periods of up to 20 ns. Maximum DC voltage on input or I/O pins is $V_{\text{CC}}+0.5\text{ V}$. See Figure 7. During voltage transitions, input or I/O pins may overshoot to $V_{\text{CC}}+2.0\text{ V}$ for periods up to 20 ns. See Figure 8.
2. Minimum DC input voltage on pins A9, OE#, ACC, and RESET# is -0.5 V . During voltage transitions, A9, OE#, ACC, and RESET# may overshoot V_{SS} to -2.0 V for periods of up to 20 ns. See Figure 7. Maximum DC input voltage on pin A9, OE#, ACC, and RESET# is $+12.5\text{ V}$ which may overshoot to $+14.0\text{ V}$ for periods up to 20 ns.
3. No more than one output may be shorted to ground at a time. Duration of the short circuit should not be greater than one second.

Stresses above those listed under “Absolute Maximum Ratings” may cause permanent damage to the device. This is a stress rating only; functional operation of the device at these or any other conditions above those indicated in the operational sections of this data sheet is not implied. Exposure of the device to absolute maximum rating conditions for extended periods may affect device reliability.

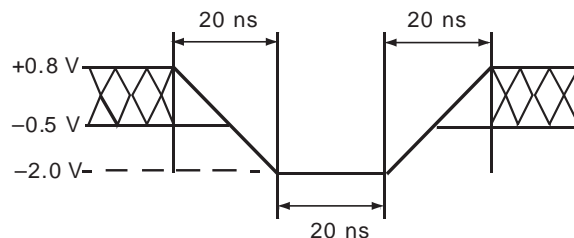

Figure 7. Maximum Negative Overshoot Waveform

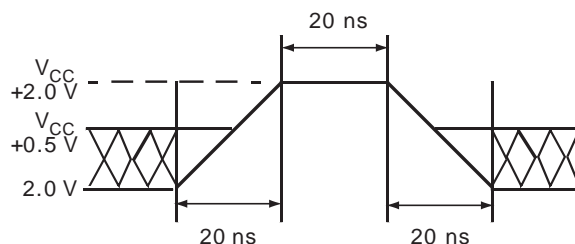

Figure 8. Maximum Positive Overshoot Waveform

OPERATING RANGES

Industrial (I) Devices

Ambient Temperature (T_A) -40°C to $+85^{\circ}\text{C}$

Supply Voltages

V_{CC} 3.0–3.6 V

V_{IO} either 1.8–2.9 V or 3.0–5.0 V

(see “Ordering Information” on page 9)

Operating ranges define those limits between which the functionality of the device is guaranteed.

DC CHARACTERISTICS

CMOS Compatible

Parameter Symbol	Parameter Description	Test Conditions	Min	Typ	Max	Unit
I_{LI}	Input Load Current (Note 1)	$V_{IN} = V_{SS}$ to V_{CC} , $V_{CC} = V_{CC\ max}$			± 1.0	μA
I_{LIT}	A9, ACC Input Load Current	$V_{CC} = V_{CC\ max}$; A9 = 12.5 V			35	μA
I_{LO}	Output Leakage Current	$V_{OUT} = V_{SS}$ to V_{CC} , $V_{CC} = V_{CC\ max}$			± 1.0	μA
I_{CC1}	V_{CC} Active Read Current (Notes 2, 3)	CE# = V_{IL} , OE# = V_{IH}	5 MHz	9	16	mA
			1 MHz	2	4	
I_{CC2}	V_{CC} Active Write Current (Notes 3, 4)	CE# = V_{IL} , OE# = V_{IH} , WE# = V_{IL}		26	30	mA
I_{CC3}	V_{CC} Standby Current (Note 3)	CE#, RESET# = $V_{CC} \pm 0.3$ V, WP# = V_{IH}		0.2	5	μA
I_{CC4}	V_{CC} Reset Current (Note 3)	RESET# = $V_{SS} \pm 0.3$ V, WP# = V_{IH}		0.2	5	μA
I_{CC5}	Automatic Sleep Mode (Notes 3, 5)	$V_{IH} = V_{CC} \pm 0.3$ V; $V_{IL} = V_{SS} \pm 0.3$ V, WP# = V_{IH}		0.2	5	μA
I_{ACC}	ACC Accelerated Program Current	CE# = V_{IL} , OE# = V_{IH}	ACC pin	5	10	mA
			V_{CC} pin	15	30	mA
V_{IL}	Input Low Voltage (Note 6)		-0.5		0.8	V
V_{IH}	Input High Voltage (Note 6)		$0.7 \times V_{CC}$		$V_{CC} + 0.3$	V
V_{HH}	Voltage for ACC Program Acceleration	$V_{CC} = 3.0$ V \pm 10%	11.5		12.5	V
V_{ID}	Voltage for Autoselect and Temporary Sector Unprotect	$V_{CC} = 3.0$ V \pm 10%	8.5		12.5	V
V_{OL}	Output Low Voltage	$I_{OL} = 4.0$ mA, $V_{CC} = V_{CC\ min}$			0.45	V
V_{OH1}	Output High Voltage	$I_{OH} = -2.0$ mA, $V_{CC} = V_{CC\ min}$	$0.8 V_{IO}$			V
V_{OH2}		$I_{OH} = -100$ μA , $V_{CC} = V_{CC\ min}$	$V_{IO} - 0.4$			V
V_{LKO}	Low V_{CC} Lock-Out Voltage (Note 7)		2.3		2.5	V

Notes:

1. On the WP# pin only, the maximum input load current when WP# = V_{IL} is ± 5.0 μA .
2. The I_{CC} current listed is typically less than 2 mA/MHz, with OE# at V_{IH} .
3. Maximum I_{CC} specifications are tested with $V_{CC} = V_{CC\ max}$.
4. I_{CC} active while Embedded Erase or Embedded Program is in progress.
5. Automatic sleep mode enables the low power mode when addresses remain stable for $t_{ACC} + 30$ ns. Typical sleep mode current is 200 nA.
6. If $V_{IO} < V_{CC}$, maximum V_{IL} for CE# and DQ I/Os is $0.3 V_{IO}$. If $V_{IO} < V_{CC}$, minimum V_{IH} for CE# and DQ I/Os is $0.7 V_{IO}$. Maximum V_{IH} for these connections is $V_{IO} + 0.3$ V.
7. Not 100% tested.

DC CHARACTERISTICS

Zero-Power Flash

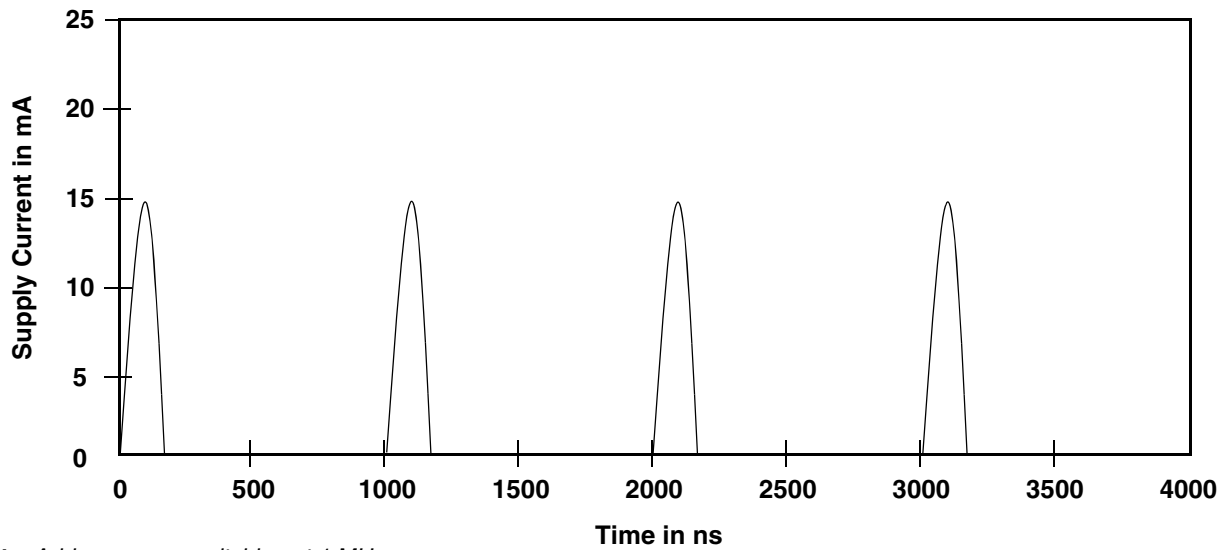

Note: Addresses are switching at 1 MHz

Figure 9. I_{CC1} Current vs. Time (Showing Active and Automatic Sleep Currents)

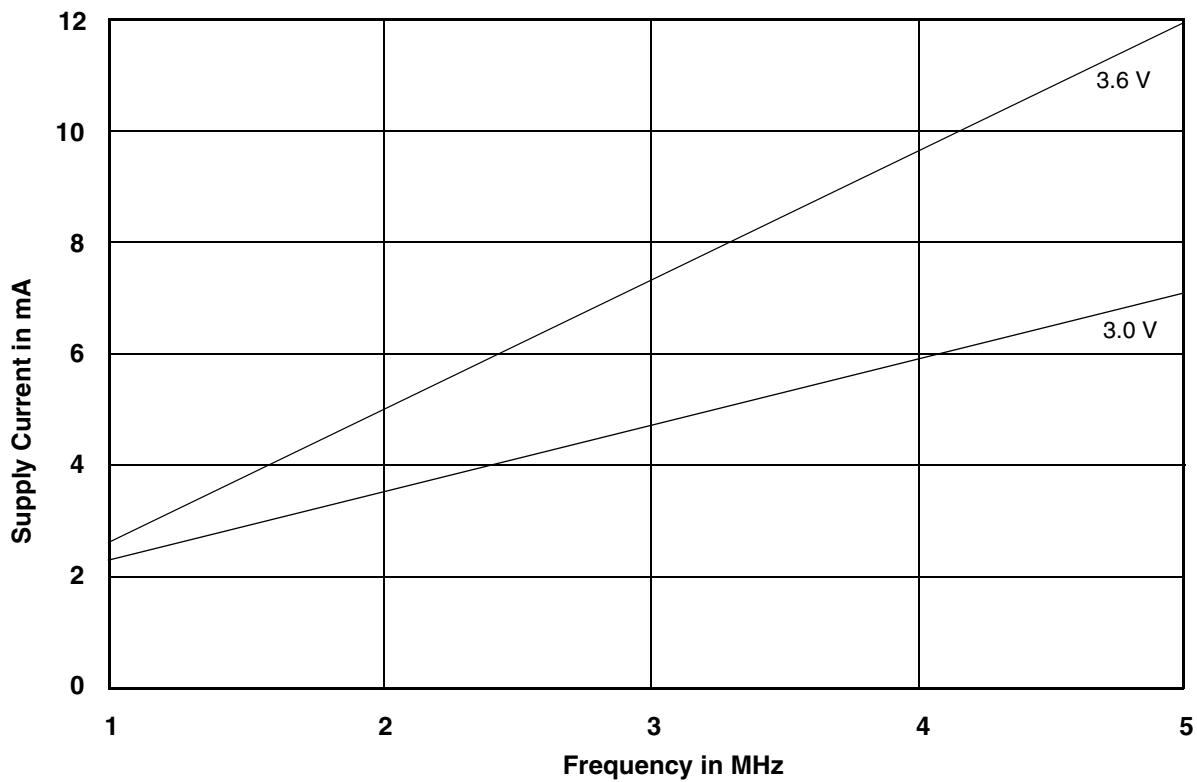

Note: $T = 25^{\circ}C$

Figure 10. Typical I_{CC1} vs. Frequency

TEST CONDITIONS

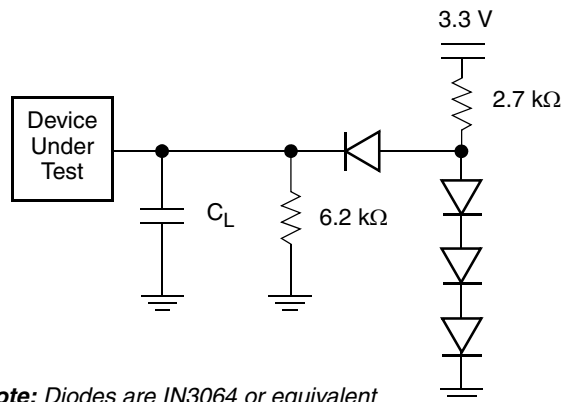

Note: Diodes are IN3064 or equivalent
Figure 11. Test Setup

Table 12. Test Specifications

Test Condition	90R	120R, 121R	Unit
Output Load	1 TTL gate		
Output Load Capacitance, C_L (including jig capacitance)	30	100	pF
Input Rise and Fall Times	5		ns
Input Pulse Levels	0.0–3.0		V
Input timing measurement reference levels (See Note)	1.5		V
Output timing measurement reference levels	0.5 V_{IO}		V

Note: If $V_{IO} < V_{CC}$, the reference level is 0.5 V_{IO} .

KEY TO SWITCHING WAVEFORMS

WAVEFORM	INPUTS	OUTPUTS
		Steady
		Changing from H to L
		Changing from L to H
	Don't Care, Any Change Permitted	Changing, State Unknown
	Does Not Apply	Center Line is High Impedance State (High Z)

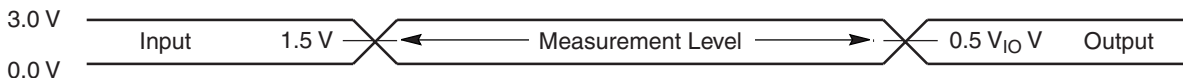

Note: If $V_{IO} < V_{CC}$, the input measurement reference level is 0.5 V_{IO} .

Figure 12. Input Waveforms and Measurement Levels

AC CHARACTERISTICS

Read-Only Operations

Parameter		Description	Test Setup		Speed Options		Unit
JEDEC	Std.				90R	120R, 121R	
t_{AVAV}	t_{RC}	Read Cycle Time (Note 1)		Min	90	120	ns
t_{AVQV}	t_{ACC}	Address to Output Delay	CE#, OE# = V_{IL}	Max	90	120	ns
t_{ELQV}	t_{CE}	Chip Enable to Output Delay	OE# = V_{IL}	Max	90	120	ns
t_{GLQV}	t_{OE}	Output Enable to Output Delay		Max	35	50	ns
t_{EHQZ}	t_{DF}	Chip Enable to Output High Z (Note 1)		Max	30	30	ns
t_{GHQZ}	t_{DF}	Output Enable to Output High Z (Note 1)		Max	30	30	ns
t_{AXQX}	t_{OH}	Output Hold Time From Addresses, CE# or OE#, Whichever Occurs First		Min	0		ns
	t_{OEh}	Output Enable Hold Time (Note 1)	Read	Min	0		ns
			Toggle and Data# Polling	Min	10		ns

Notes:

1. Not 100% tested.
2. See Figure 11 and Table 12 for test specifications.

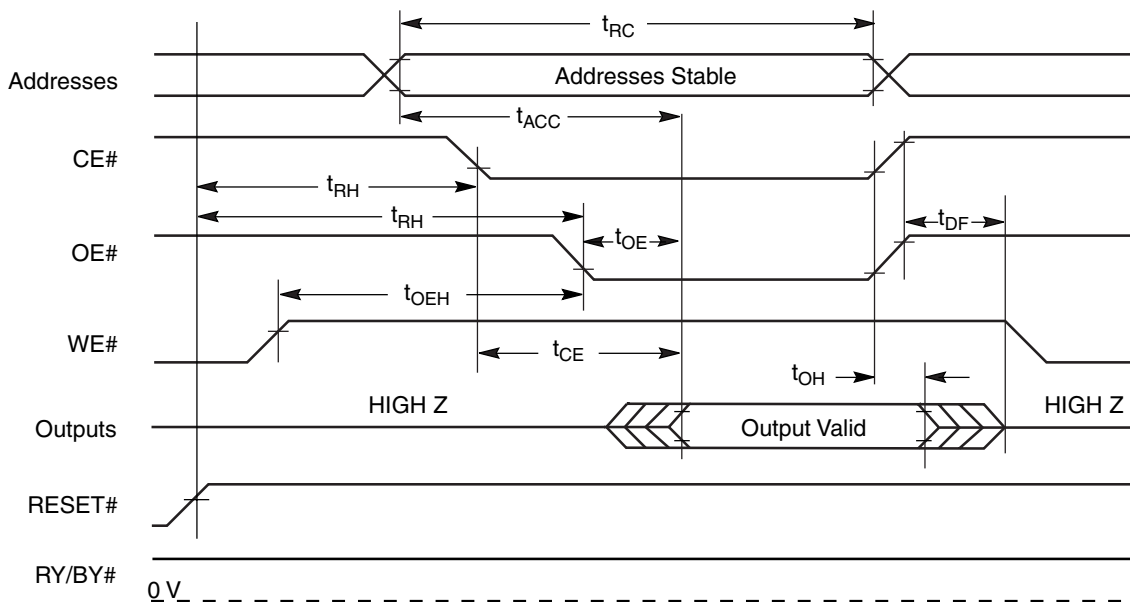

Figure 13. Read Operation Timings

AC CHARACTERISTICS

Hardware Reset (RESET#)

Parameter		Description		All Speed Options	Unit
JEDEC	Std				
	t_{Ready}	RESET# Pin Low (During Embedded Algorithms) to Read Mode (See Note)	Max	20	μ s
	t_{Ready}	RESET# Pin Low (NOT During Embedded Algorithms) to Read Mode (See Note)	Max	500	ns
	t_{RP}	RESET# Pulse Width	Min	500	ns
	t_{RH}	Reset High Time Before Read (See Note)	Min	50	ns
	t_{RPD}	RESET# Low to Standby Mode	Min	20	μ s
	t_{RB}	RY/BY# Recovery Time	Min	0	ns

Note: Not 100% tested.

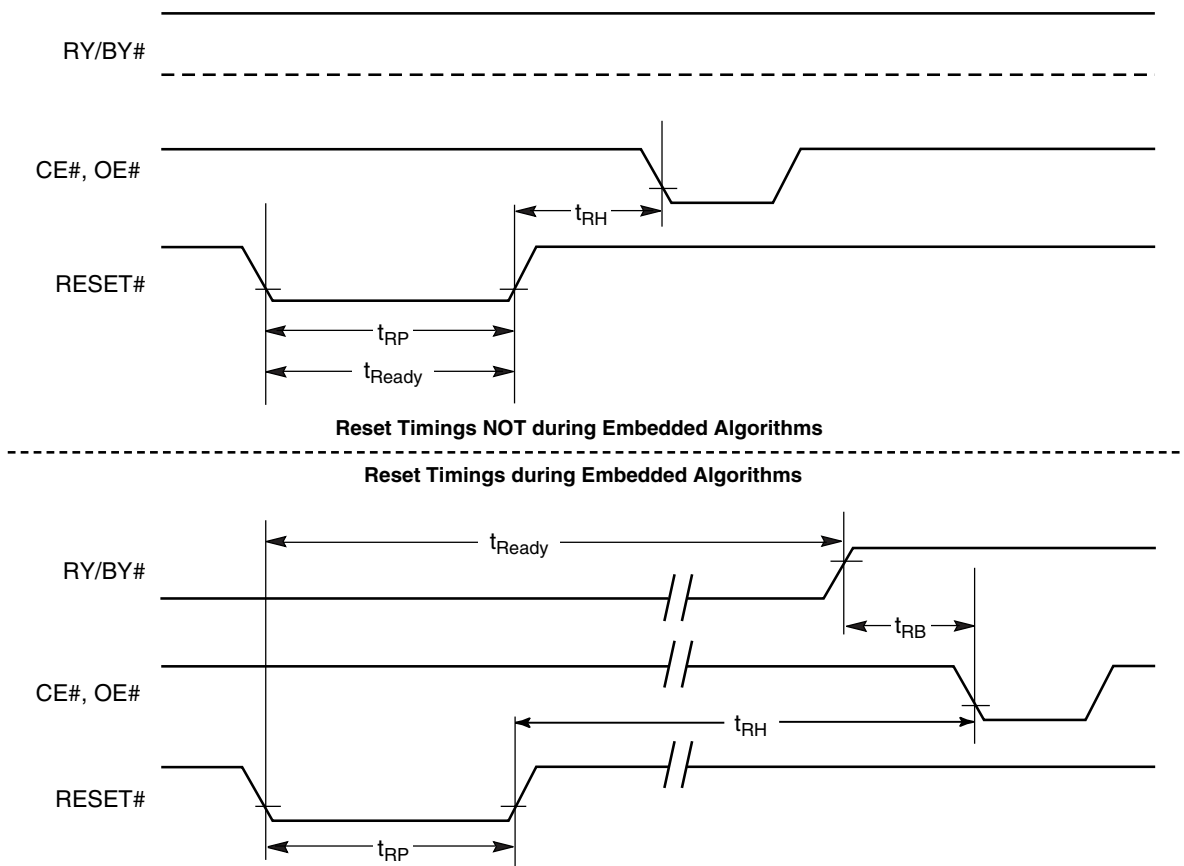

Figure 14. Reset Timings

AC CHARACTERISTICS

Erase and Program Operations

Parameter		Description		Speed Options		Unit
JEDEC	Std.			90R	120R, 121R	
t_{AVAV}	t_{WC}	Write Cycle Time (Note 1)	Min	90	120	ns
t_{AVWL}	t_{AS}	Address Setup Time	Min	0		ns
	t_{ASO}	Address Setup Time to OE# low during toggle bit polling	Min	15		ns
t_{WLAX}	t_{AH}	Address Hold Time	Min	45	50	ns
	t_{AHT}	Address Hold Time From CE# or OE# high during toggle bit polling	Min	0		ns
t_{DVWH}	t_{DS}	Data Setup Time	Min	45	50	ns
t_{WHDX}	t_{DH}	Data Hold Time	Min	0		ns
	t_{OEPH}	Output Enable High during toggle bit polling	Min	20		ns
t_{GHWL}	t_{GHWL}	Read Recovery Time Before Write (OE# High to WE# Low)	Min	0		ns
t_{ELWL}	t_{CS}	CE# Setup Time	Min	0		ns
t_{WHEH}	t_{CH}	CE# Hold Time	Min	0		ns
t_{WLWH}	t_{WP}	Write Pulse Width	Min	35	50	ns
t_{WHDL}	t_{WPH}	Write Pulse Width High	Min	30		ns
t_{WHWH1}	t_{WHWH1}	Word Programming Operation (Note 2)	Typ	11		μ s
t_{WHWH1}	t_{WHWH1}	Accelerated Word Programming Operation (Note 2)	Typ	7		μ s
t_{WHWH2}	t_{WHWH2}	Sector Erase Operation (Note 2)	Typ	0.9		sec
	t_{VHH}	V_{HH} Rise and Fall Time (Note 1)	Min	250		ns
	t_{VCS}	V_{CC} Setup Time (Note 1)	Min	50		μ s
	t_{RB}	Write Recovery Time from RY/BY#	Min	0		ns
	t_{BUSY}	Program/Erase Valid to RY/BY# Delay	Min	90		ns

Notes:

1. Not 100% tested.
2. See the "Erase And Programming Performance" section for more information.

AC CHARACTERISTICS

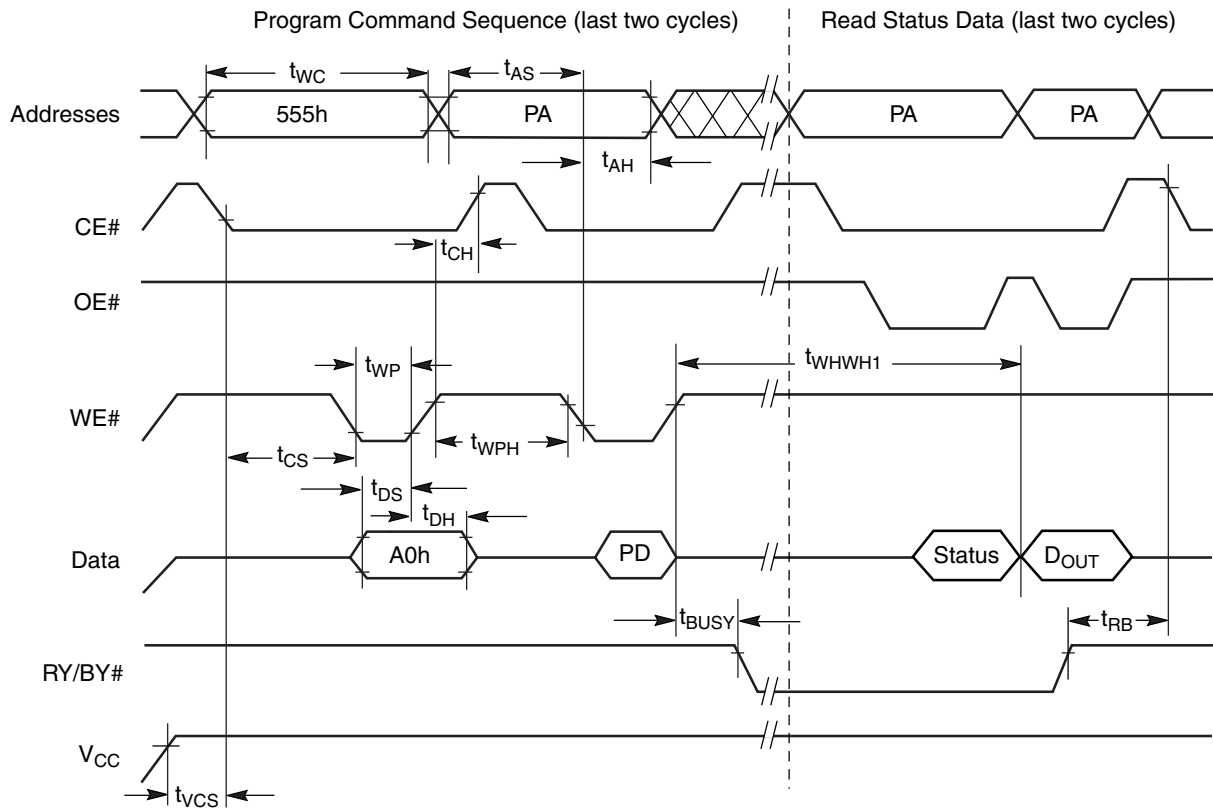

Notes:

1. PA = program address, PD = program data, D_{OUT} is the true data at the program address.
2. Illustration shows device in word mode.

Figure 15. Program Operation Timings

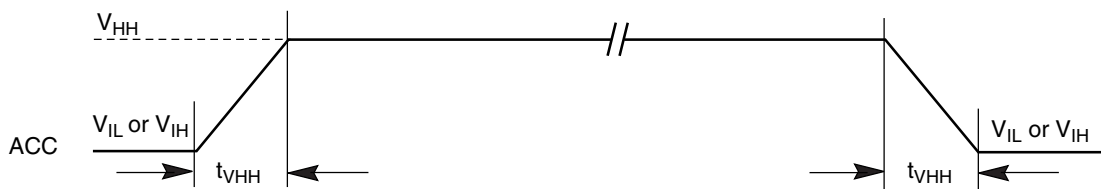
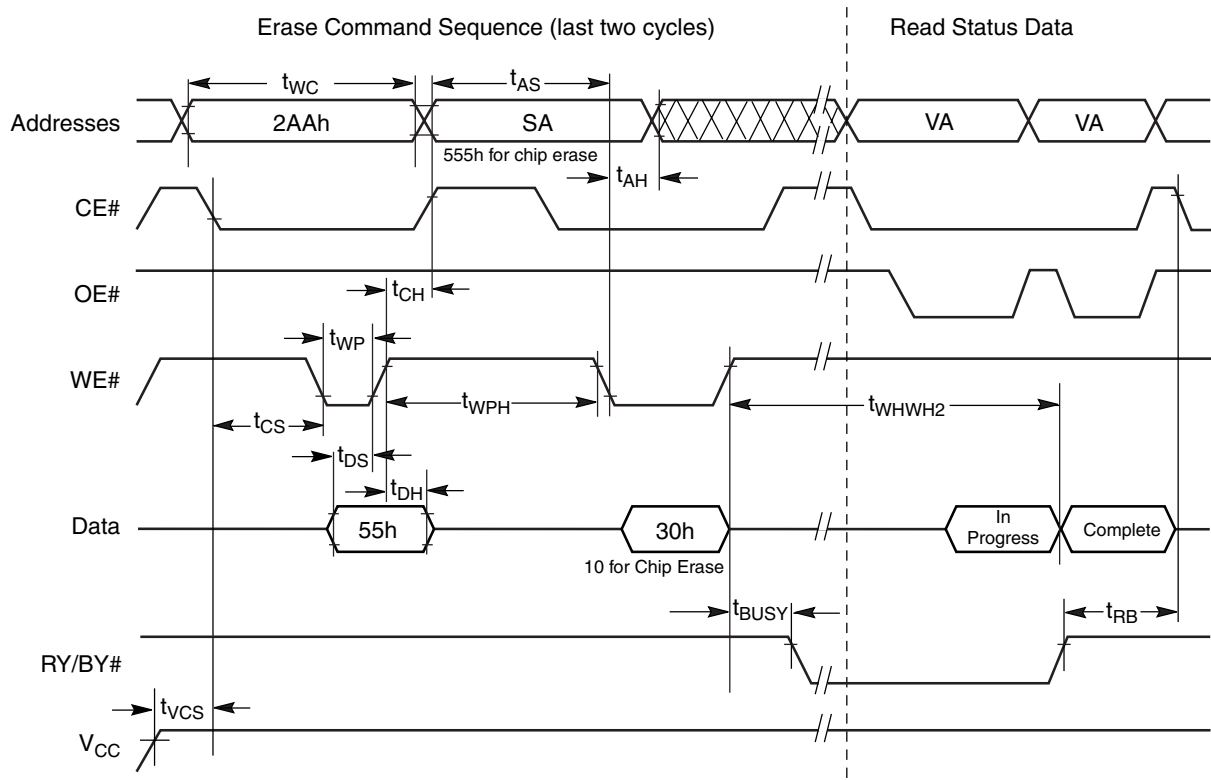

Figure 16. Accelerated Program Timing Diagram

AC CHARACTERISTICS



Notes:

1. SA = sector address (for Sector Erase), VA = Valid Address for reading status data (see "Write Operation Status").
2. These waveforms are for the word mode.

Figure 17. Chip/Sector Erase Operation Timings

AC CHARACTERISTICS

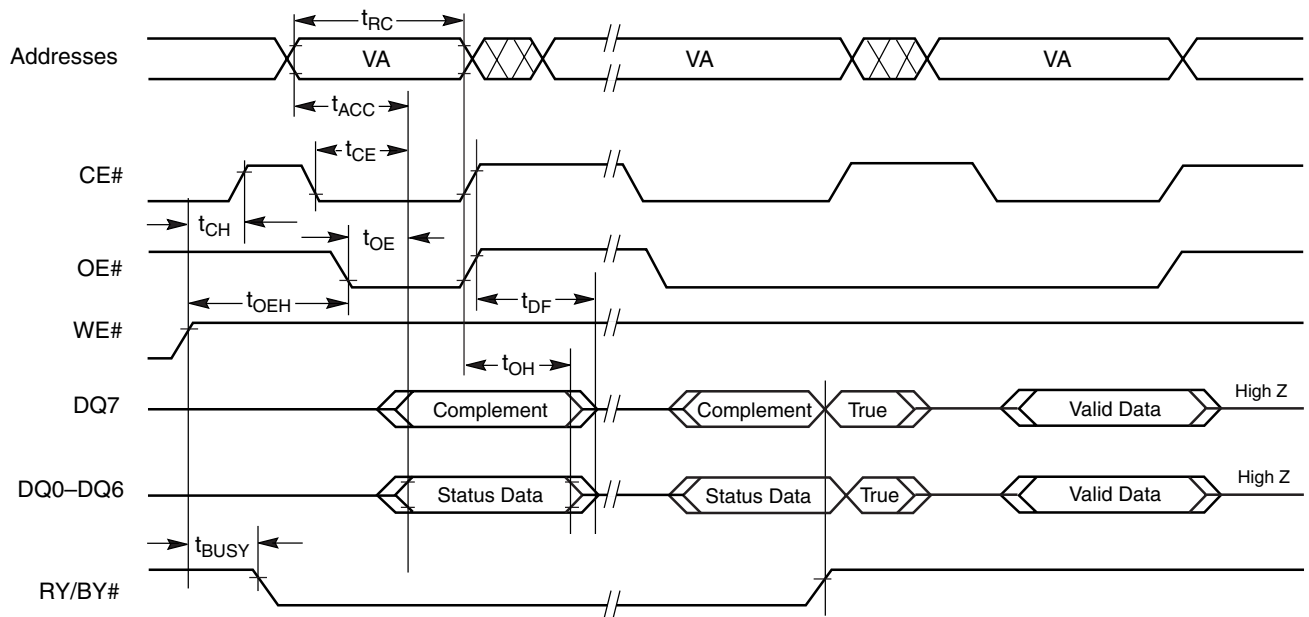

Note: VA = Valid address. Illustration shows first status cycle after command sequence, last status read cycle, and array data read cycle.

Figure 18. Data# Polling Timings (During Embedded Algorithms)

AC CHARACTERISTICS

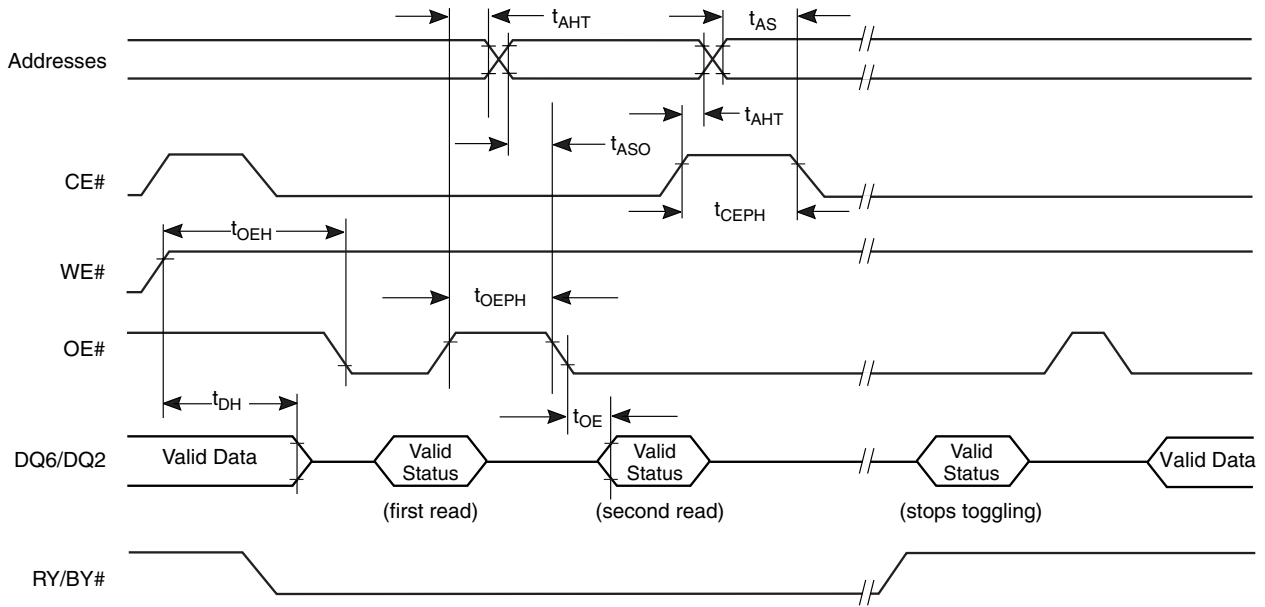

Note: VA = Valid address; not required for DQ6. Illustration shows first two status cycle after command sequence, last status read cycle, and array data read cycle

Figure 19. Toggle Bit Timings (During Embedded Algorithms)

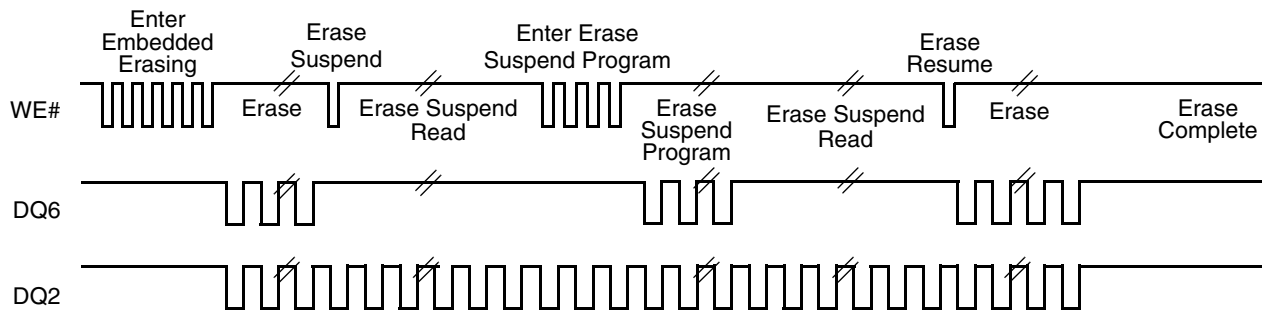

Note: DQ2 toggles only when read at an address within an erase-suspended sector. The system may use OE# or CE# to toggle DQ2 and DQ6.

Figure 20. DQ2 vs. DQ6

AC CHARACTERISTICS

Temporary Sector Unprotect

Parameter		Description		All Speed Options	Unit
JEDEC	Std				
	t_{VIDR}	V_{ID} Rise and Fall Time (See Note)	Min	500	ns
	t_{RSP}	RESET# Setup Time for Temporary Sector Unprotect	Min	4	μ s
	t_{RRB}	RESET# Hold Time from RY/BY# High for Temporary Sector Group Unprotect	Min	4	μ s

Note: Not 100% tested.

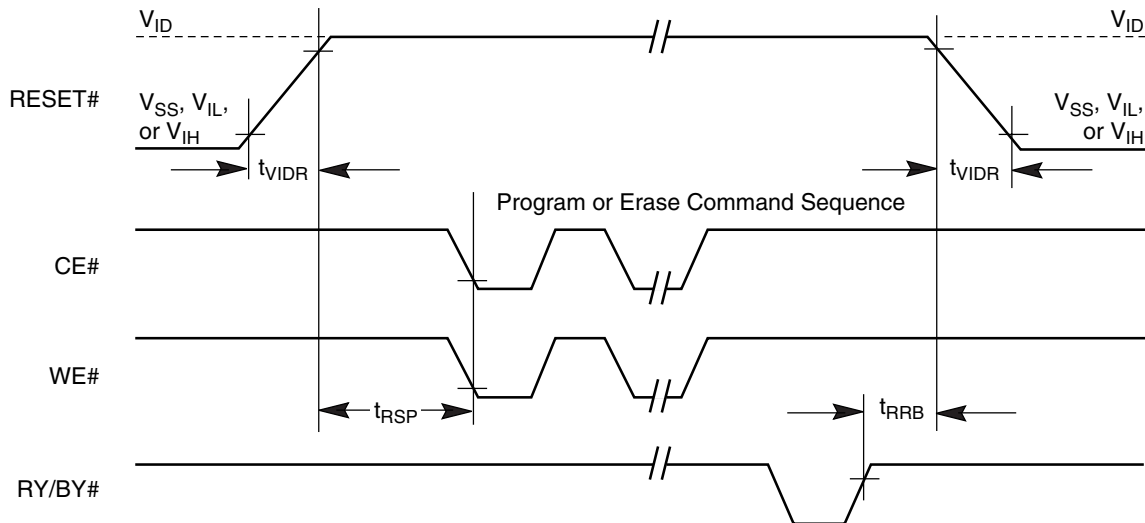
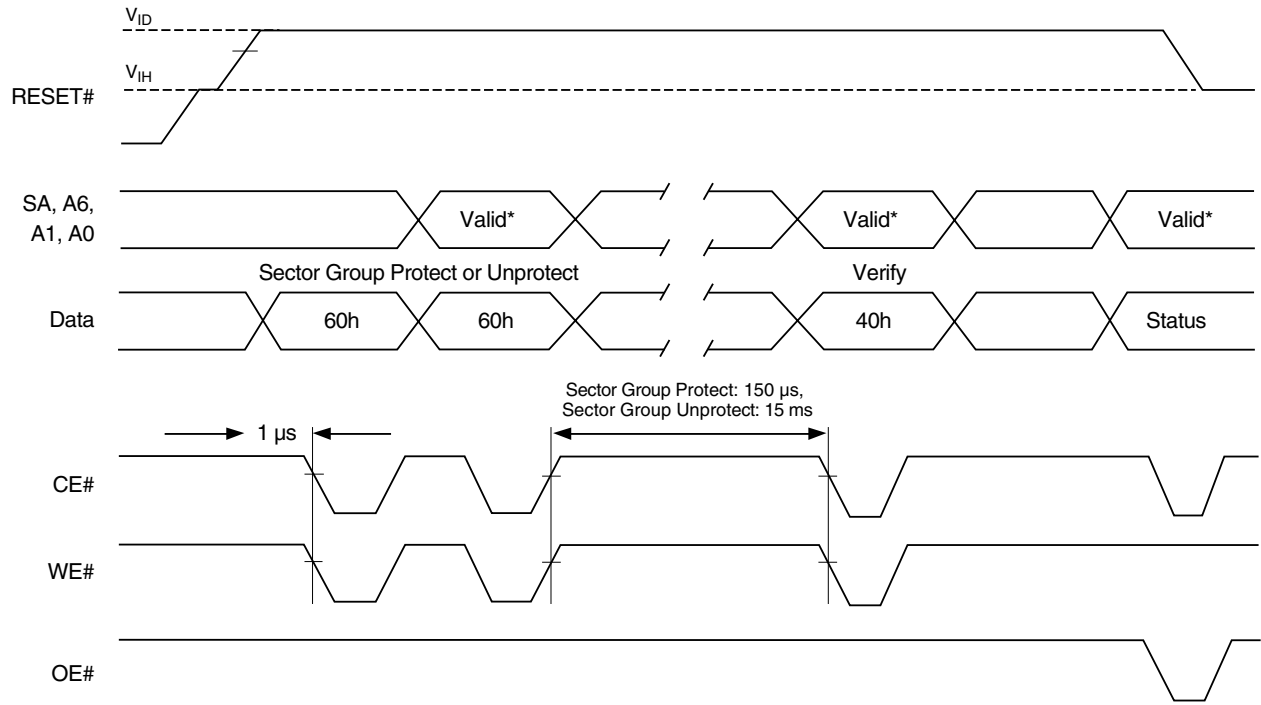

Figure 21. Temporary Sector Group Unprotect Timing Diagram

AC CHARACTERISTICS



* For sector group protect, A6 = 0, A1 = 1, A0 = 0. For sector group unprotect, A6 = 1, A1 = 1, A0 = 0.

Figure 22. Sector Group Protect and Unprotect Timing Diagram

AC CHARACTERISTICS

Alternate CE# Controlled Erase and Program Operations

Parameter		Description		Speed Options		Unit
JEDEC	Std			90R	120R, 121R	
t_{AVAV}	t_{WC}	Write Cycle Time (Note 1)	Min	90	120	ns
t_{AVWL}	t_{AS}	Address Setup Time	Min	0		ns
t_{ELAX}	t_{AH}	Address Hold Time	Min	45	50	ns
t_{DVEH}	t_{DS}	Data Setup Time	Min	45	50	ns
t_{EHDX}	t_{DH}	Data Hold Time	Min	0		ns
t_{GHLEL}	t_{GHLEL}	Read Recovery Time Before Write (OE# High to WE# Low)	Min	0		ns
t_{WLEL}	t_{WS}	WE# Setup Time	Min	0		ns
t_{EHWH}	t_{WH}	WE# Hold Time	Min	0		ns
t_{ELEH}	t_{CP}	CE# Pulse Width	Min	45	50	ns
t_{EHEL}	t_{CPH}	CE# Pulse Width High	Min	30		ns
t_{WHWH1}	t_{WHWH1}	Word Programming Operation (Note 2)	Typ	11		μ s
t_{WHWH1}	t_{WHWH1}	Accelerated Word Programming Operation (Note 2)	Typ	7		μ s
t_{WHWH2}	t_{WHWH2}	Sector Erase Operation (Note 2)	Typ	0.9		sec

Notes:

1. Not 100% tested.
2. See the "Erase And Programming Performance" section for more information.

AC CHARACTERISTICS

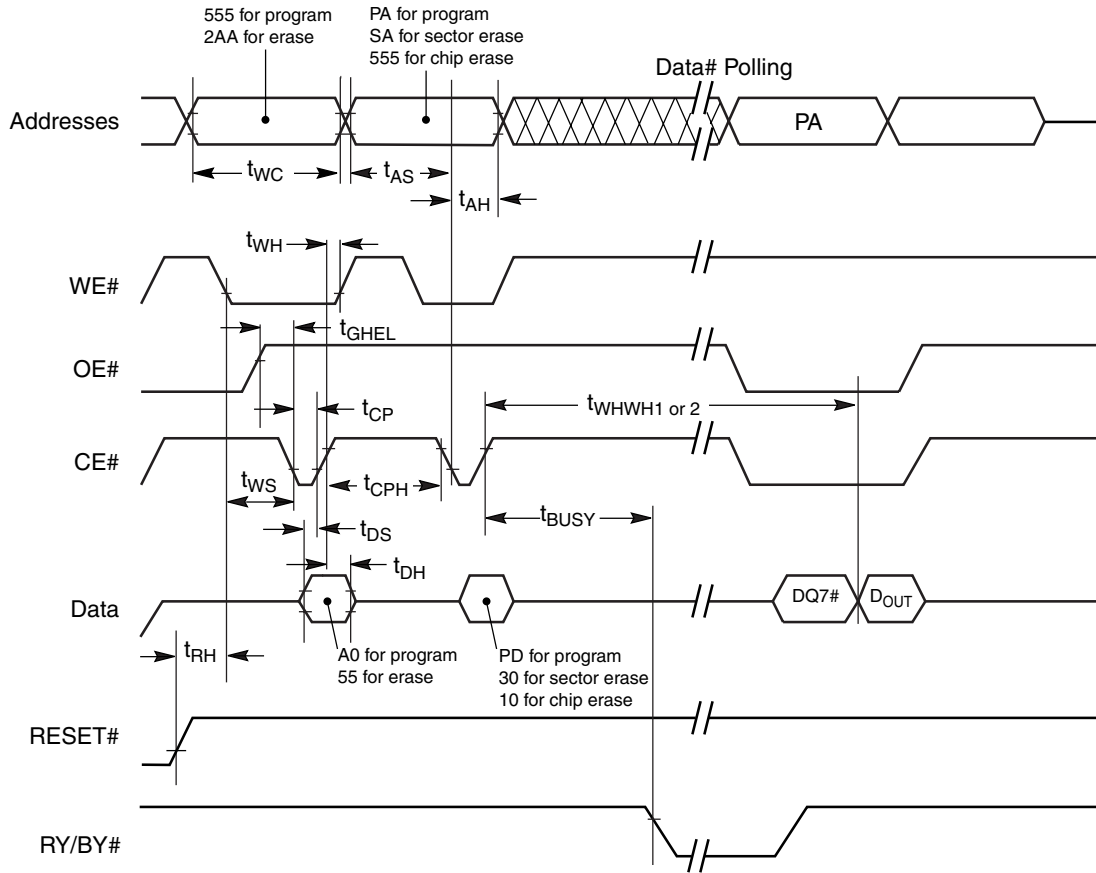

Notes:

1. Figure indicates last two bus cycles of a program or erase operation.
2. PA = program address, SA = sector address, PD = program data.
3. DQ7# is the complement of the data written to the device. D_{OUT} is the data written to the device.
4. Waveforms are for the word mode.

Figure 23. Alternate CE# Controlled Write (Erase/Program) Operation Timings

ERASE AND PROGRAMMING PERFORMANCE

Parameter	Typ (Note 1)	Max (Note 2)	Unit	Comments
Sector Erase Time	0.9	15	sec	Excludes 00h programming prior to erasure (Note 4)
Chip Erase Time	115		sec	
Word Program Time	11	300	μs	Excludes system level overhead (Note 5)
Accelerated Word Program Time	7	210	μs	
Chip Program Time (Note 3)	48	144	sec	

Notes:

1. Typical program and erase times assume the following conditions: 25°C, 3.0 V V_{CC} , 1,000,000 cycles. Additionally, programming typicals assume checkerboard pattern.
2. Under worst case conditions of 90°C, $V_{CC} = 3.0$ V, 1,000,000 cycles.
3. The typical chip programming time is considerably less than the maximum chip programming time listed, since most words program faster than the maximum program times listed.
4. In the pre-programming step of the Embedded Erase algorithm, all bits are programmed to 00h before erasure.
5. System-level overhead is the time required to execute the two- or four-bus-cycle sequence for the program command. See Table 10 for further information on command definitions.
6. The device has a minimum erase and program cycle endurance of 1,000,000 cycles.

LATCHUP CHARACTERISTICS

Description	Min	Max
Input voltage with respect to V_{SS} on all pins except I/O pins (including A9, OE#, and RESET#)	-1.0 V	12.5 V
Input voltage with respect to V_{SS} on all I/O pins	-1.0 V	$V_{CC} + 1.0$ V
V_{CC} Current	-100 mA	+100 mA

Note: Includes all pins except V_{CC} . Test conditions: $V_{CC} = 3.0$ V, one pin at a time.

TSOP PIN CAPACITANCE

Parameter Symbol	Parameter Description	Test Setup	Typ	Max	Unit
C_{IN}	Input Capacitance	$V_{IN} = 0$	6	7.5	pF
C_{OUT}	Output Capacitance	$V_{OUT} = 0$	8.5	12	pF
C_{IN2}	Control Pin Capacitance	$V_{IN} = 0$	7.5	9	pF

Notes:

1. Sampled, not 100% tested.
2. Test conditions $T_A = 25^\circ\text{C}$, $f = 1.0$ MHz.

DATA RETENTION

Parameter Description	Test Conditions	Min	Unit
Minimum Pattern Data Retention Time	150°C	10	Years
	125°C	20	Years

PHYSICAL DIMENSIONS

SSO056—56-Pin Shrink Small Outline Package (SSOP)

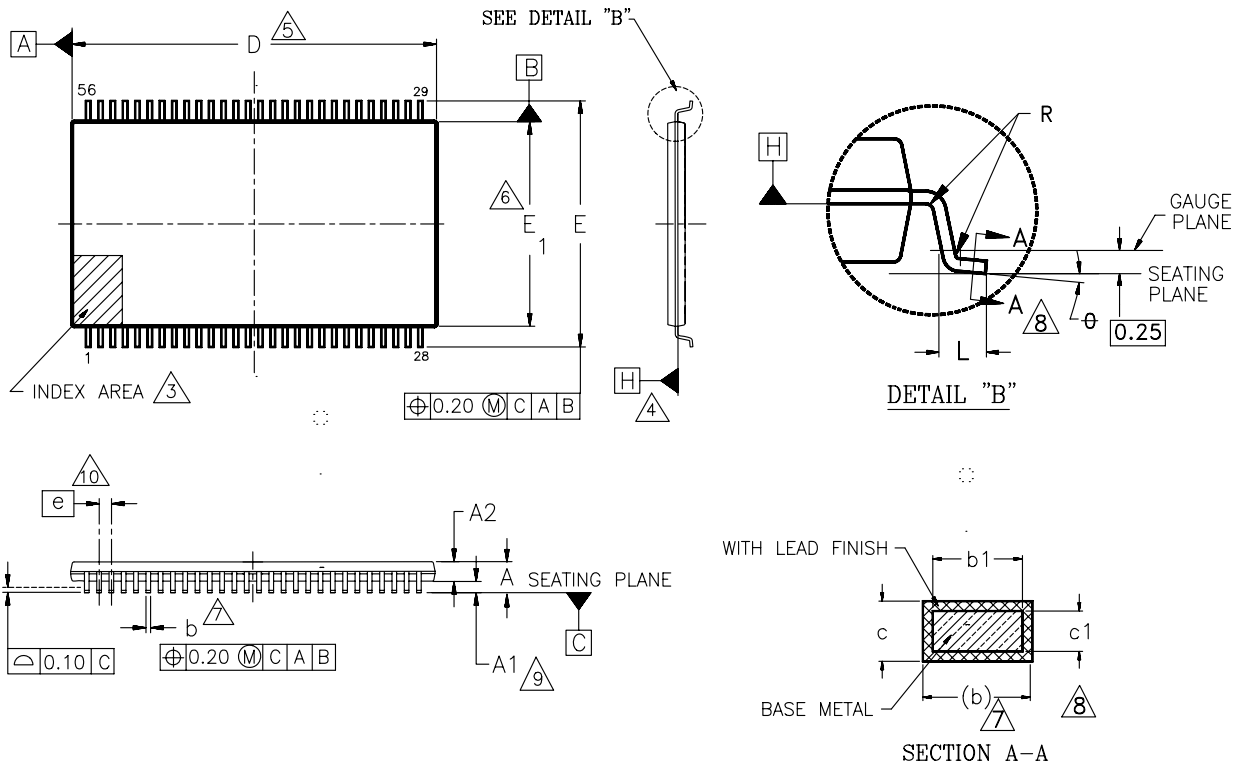

Dwg rev AB; 10/99

PACKAGE	SSO 056		
JEDEC	MO-180 (A) BA		
SYMBOL	MIN	NOM	MAX
A	—	—	2.00
A1	0.45	—	0.65
A2	1.15	1.25	1.35
b	* 0.25	—	0.45
b1	0.30	0.35	0.40
c	0.10	—	0.21
c1	0.10	0.15	0.18
D	23.40	23.70	24.00
E	15.70	16.00	16.30
E1	13.10	13.30	13.50
e	0.80 BSC		
L	0.60	0.80	1.00
R	0.09	—	—
θ	0°	4°	8°

* -DEVIATES FROM JEDEC (0.30)

NOTES:

- CONTROLLING DIMENSIONS ARE IN MILLIMETERS (mm).
- DIMENSIONING AND TOLERANCING CONFORM TO ASME Y14.5M-1994.
- A VISUAL INDEX FEATURE MUST BE LOCATED WITHIN THE CROSSHATCHED AREA.
- DATUMS A AND B AND DIMENSIONS D AND E1 ARE DETERMINED AT DATUM H.
- DIMENSION "D" DOES NOT INCLUDE MOLD FLASH, PROTUSIONS OR GATE BURRS. MOLD FLASH, PROTUSIONS OR GATE BURRS SHALL NOT EXCEED 0.15 mm PER END.
- DIMENSION "E1" DOES NOT INCLUDE INTERLEAD FLASH OR PROTRUSION. INTERLEAD FLASH OR PROTRUSION SHALL NOT EXCEED 0.15 mm PER SIDE.
- DIMENSION b DOES NOT INCLUDE DAMBAR PROTRUSION/INTRUSION. ALLOWABLE DAMBAR PROTRUSION SHALL NOT EXCEED 0.15 mm PER SIDE. DAMBAR INTRUSION SHALL NOT REDUCE DIMENSION b BY MORE THAN 0.07 mm AT LEAST MATERIAL CONDITION.
- THESE DIMENSIONS APPLY TO THE FLAT SECTION OF THE LEAD BETWEEN 0.10 mm AND 0.25 mm FROM THE LEAD TIPS.
- A1 IS DEFINED AS THE DISTANCE FROM THE SEATING PLANE TO THE LOWEST POINT OF THE PACKAGE.
- DIMENSION "e" IS MEASURED AT THE CENTERLINE OF THE LEADS.
- LEAD COPLANARITY SHALL BE WITHIN 0.10 mm AS MEASURED FROM THE SEATING PLANE.

PHYSICAL DIMENSIONS

FBE063—63-Ball Fine-Pitch Ball Grid Array (FBGA) 12 x 11 mm package

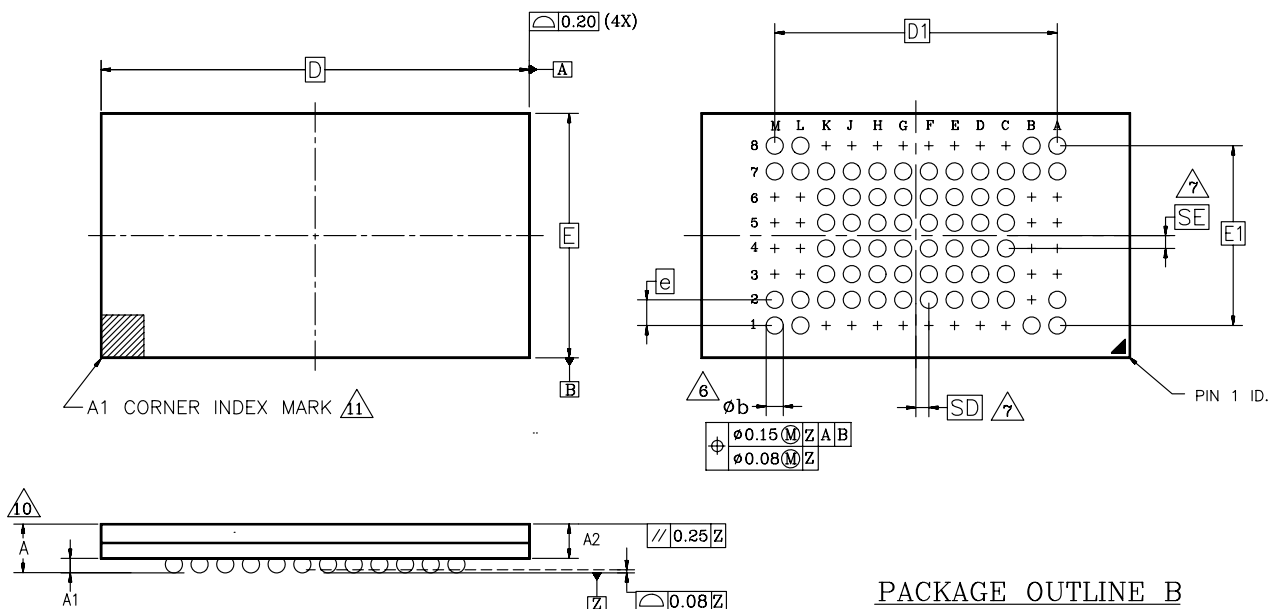

PACKAGE OUTLINE B

Dwg rev AF; 10/99

PACKAGE	x FBE 063			NOTE
JEDEC	N/A			
	12.00mmx11.00mm PACKAGE			
SYMBOL	MIN	NOM	MAX	NOTE
A	—	—	1.20	OVERALL THICKNESS
A1	0.20	—	—	BALL HEIGHT
A2	0.84	—	0.94	BODY THICKNESS
D	12.00 BSC			BODY SIZE
E	11.00 BSC			BODY SIZE
D1	8.80 BSC			BALL FOOTPRINT
E1	5.60 BSC			BALL FOOTPRINT
MD	12			ROW MATRIX SIZE D DIRECTION
ME	8			ROW MATRIX SIZE E DIRECTION
N	63			TOTAL BALL COUNT
b	0.25	0.30	0.35	BALL DIAMETER
e	0.80 BSC			BALL PITCH
SD/SE	0.40 BSC			SOLDER BALL PLACEMENT
	A3–A6, B2–B6 L3–L6, M3–M6 C1–K1, C8–K8			DEPOPULATED SOLDER BALLS

NOTES:

- DIMENSIONING AND TOLERANCING PER ASME Y14.5M–1994.
- ALL DIMENSIONS ARE IN MILLIMETERS.
- BALL POSITION DESIGNATION PER JESD 95–1, SPP–010.
- [e] REPRESENTS THE SOLDER BALL GRID PITCH.
- SYMBOL "MD" IS THE BALL ROW MATRIX SIZE IN THE "D" DIRECTION. SYMBOL "ME" IS THE BALL COLUMN MATRIX SIZE IN THE "E" DIRECTION. N IS THE MAXIMUM NUMBER OF SOLDER BALLS FOR MATRIX SIZE MD x ME.
- DIMENSION "b" IS MEASURED AT THE MAXIMUM BALL DIAMETER IN A PLANE PARALLEL TO DATUM Z.
- SD AND SE ARE MEASURED WITH RESPECT TO DATUMS A AND B AND DEFINE THE POSITION OF THE CENTER SOLDER BALL IN THE OUTER ROW. WHEN THERE IS AN ODD NUMBER OF SOLDER BALLS IN THE OUTER ROW PARALLEL TO THE D OR E DIMENSION, RESPECTIVELY, SD OR SE = 0.000 WHEN THERE IS AN EVEN NUMBER OF SOLDER BALLS IN THE OUTER ROW, SD OR SE = $e/2$
- "X" IN THE PACKAGE VARIATIONS DENOTES PART IS UNDER QUALIFICATION.
- "+" IN THE PACKAGE DRAWING INDICATE THE THEORETICAL CENTER OF DEPOPULATED BALLS.
- FOR PACKAGE THICKNESS A IS THE CONTROLLING DIMENSION.
- A1 CORNER TO BE IDENTIFIED BY CHAMFER, INK MARK, METALLIZED MARKINGS INDENTATION OR OTHER MEANS.

PHYSICAL DIMENSIONS

LAA064—64-Ball Fortified Ball Grid Array (FBGA) 13 x 11 mm package

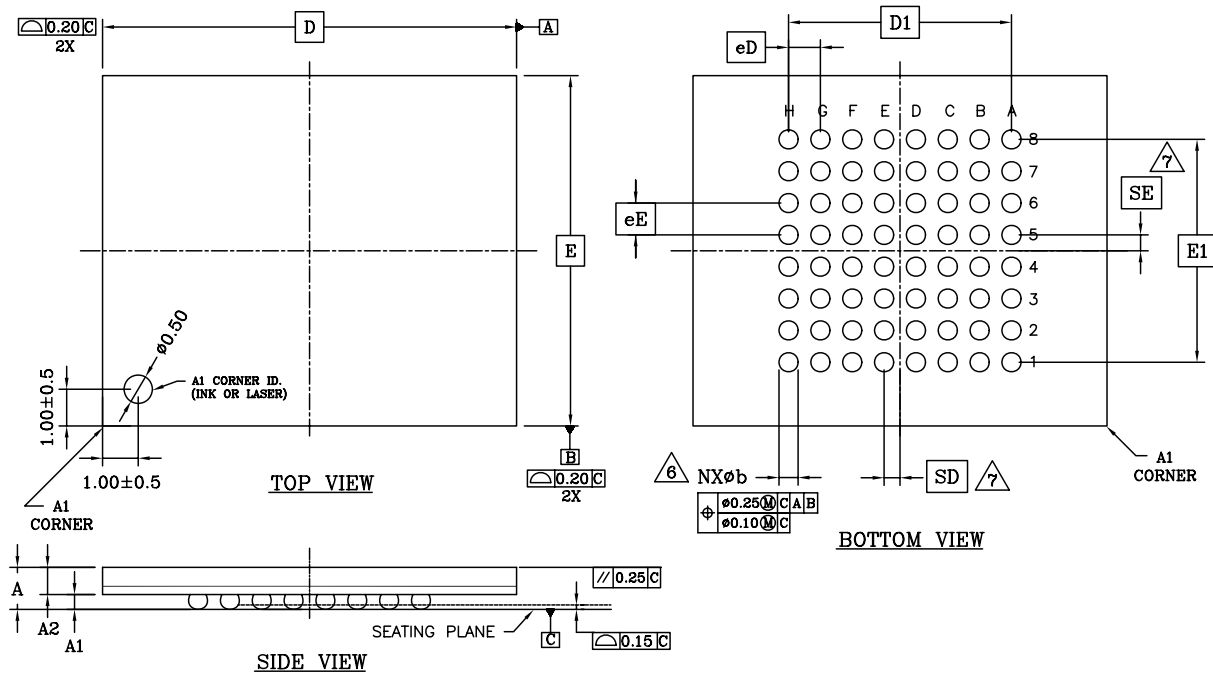

PACKAGE	LAA 064			
JEDEC	N/A			
	13.00x11.00 mm PACKAGE			
SYMBOL	MIN.	NOM.	MAX.	NOTE
A	-	-	1.40	PROFILE HEIGHT
A1	0.40	-	-	STANDOFF
A2	0.60	-	-	BODY THICKNESS
D	13.00 BSC.			BODY SIZE
E	11.00 BSC.			BODY SIZE
D1	7.00 BSC.			MATRIX FOOTPRINT
E1	7.00 BSC.			MATRIX FOOTPRINT
MD	8			MATRIX SIZE D DIRECTION
ME	8			MATRIX SIZE E DIRECTION
N	64			BALL COUNT
øb	0.50	0.60	0.70	BALL DIAMETER
eD	1.00 BSC.			BALL PITCH - D DIRECTION
eE	1.00 BSC.			BALL PITCH - E DIRECTION
SD/SE	0.50 BSC.			SOLDER BALL PLACEMENT
	A1-AB, K1-K8			DEPOPULATED SOLDER BALLS

NOTES:

- DIMENSIONING AND TOLERANCING METHODS PER ASME Y14.5M-1994 .
- ALL DIMENSIONS ARE IN MILLIMETERS .
- BALL POSITION DESIGNATION PER JESD 95-1, SPP-010 (EXCEPT AS NOTED).
- [e] REPRESENTS THE SOLDER BALL GRID PITCH .
- SYMBOL "MD" IS THE BALL MATRIX SIZE IN THE "D" DIRECTION.
SYMBOL "ME" IS THE BALL COLUMN MATRIX SIZE IN THE "E" DIRECTION.
N IS THE NUMBER OF POPULATED SOLDER BALL POSITIONS FOR MATRIX SIZE MD X ME.
- ⚠️ DIMENSION "b" IS MEASURED AT THE MAXIMUM BALL DIAMETER IN A PLANE PARALLEL TO DATUM "C".
- ⚠️ SD AND SE ARE MEASURED WITH RESPECT TO DATUMS A AND B AND DEFINE THE POSITION OF THE CENTER SOLDER BALL IN THE OUTER ROW.
WHEN THERE IS AN ODD NUMBER OF SOLDER BALLS IN THE OUTER ROW, SD OR SE = 0.000.
WHEN THERE IS AN EVEN NUMBER OF SOLDER BALLS IN THE OUTER ROW, SD OR SE = $\frac{e}{2}$
- "X" IN THE PACKAGE VARIATIONS DENOTES PART IS UNDER QUALIFICATION.
- "+" INDICATES THE THEORETICAL CENTER OF DEPOPULATED BALLS.

PHYSICAL DIMENSIONS

TS 048—48-Pin Standard TSOP

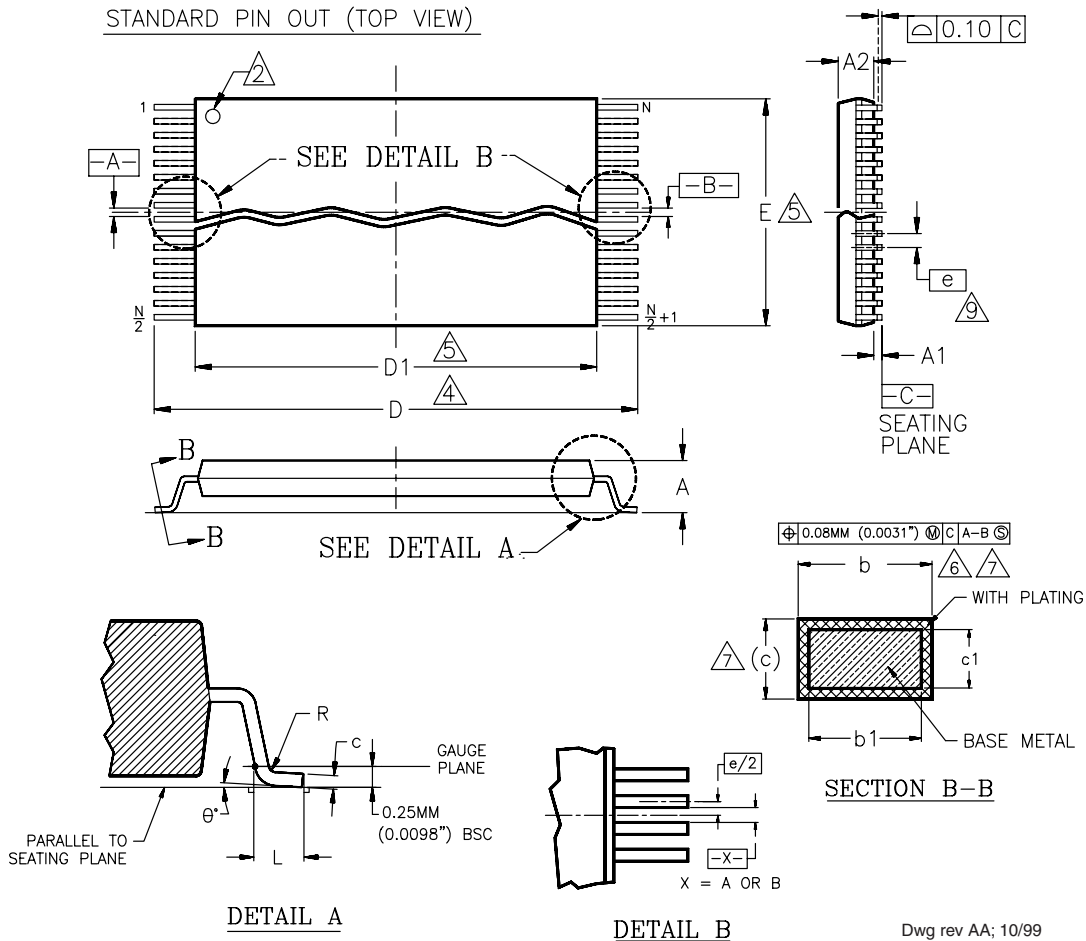

Package	TS 48		
Jedec	MO-142 (B) DD		
Symbol	MIN	NOM	MAX
A	—	—	1.20
A1	0.05	—	0.15
A2	0.95	1.00	1.05
b1	0.17	0.20	0.23
b	0.17	0.22	0.27
c1	0.10	—	0.16
c	0.10	—	0.21
D	19.80	20.00	20.20
D1	18.30	18.40	18.50
E	11.90	12.00	12.10
e	0.50 BASIC		
L	0.50	0.60	0.70
θ	0°	3°	5°
R	0.08	—	0.20
N	48		

NOTES:

1. CONTROLLING DIMENSIONS ARE IN MILLIMETERS (mm). (DIMENSIONING AND TOLERANCING CONFORMS TO ANSI Y14.5M-1982)
2. PIN 1 IDENTIFIER FOR STANDARD PIN OUT (DIE UP).
3. PIN 1 IDENTIFIER FOR REVERSE PIN OUT (DIE DOWN): INK OR LASER MARK.
4. TO BE DETERMINED AT THE SEATING PLANE [-C-]. THE SEATING PLANE IS DEFINED AS THE PLANE OF CONTACT THAT IS MADE WHEN THE PACKAGE LEADS ARE ALLOWED TO REST FREELY ON A FLAT HORIZONTAL SURFACE.
5. DIMENSIONS D1 AND E DO NOT INCLUDE MOLD PROTRUSION. ALLOWABLE MOLD PROTRUSION IS 0.15mm (0.0059") PER SIDE.
6. DIMENSION b DOES NOT INCLUDE DAMBAR PROTRUSION. ALLOWABLE DAMBAR PROTRUSION SHALL BE 0.08mm (0.0031") TOTAL IN EXCESS OF b DIMENSION AT MAX. MATERIAL CONDITION. MINIMUM SPACE BETWEEN PROTRUSION AND AN ADJACENT LEAD TO BE 0.07mm (0.0028").
7. THESE DIMENSIONS APPLY TO THE FLAT SECTION OF THE LEAD BETWEEN 0.10mm (0.0039") AND 0.25mm (0.0098") FROM THE LEAD TIP.
8. LEAD COPLANARITY SHALL BE WITHIN 0.10mm (0.004") AS MEASURED FROM THE SEATING PLANE.
9. DIMENSION "e" IS MEASURED AT THE CENTERLINE OF THE LEADS.

Note: For reference only. BSC is an ANSI standard for Basic Space Centering.

* For reference only. BSC is an ANSI standard for Basic Space Centering.

REVISION SUMMARY

Revision A (April 26, 1999)

Initial release.

Revision A+1 (May 4, 1999)

Global

Deleted references to the 4-word unique ESN. Replaced references to V_{CCQ} with V_{IO} .

Connection Diagrams

63-ball FBGA: Corrected signal for ball H7 to V_{IO} .

Ordering Information

Added "U" designator description.

SecSi (Secured Silicon) Sector Flash Memory Region

In the third paragraph, replaced references to boot sectors with SA0. Added table to show SecSi sector contents.

DC Characteristics table

Added $V_{IO} = V_{CC}$ as a test condition for I_{CC1} and I_{CC2} . Changed V_{HH} minimum specification from 8.5 V to 11.5 V.

Revision A+2 (May 14, 1999)

Ordering Information

Clarified the differences between the H, L, and U designators.

Revision A+3 (June 7, 1999)

Product Selector Guide

Added note under table.

Ordering Information

Deleted the "0" from the 120 and 150 ns part numbers. Corrected the FBGA package marking for the 150 ns speed option.

Revision A+4 (June 25, 1999)

Global

Information on the 56-pin SSOP package has been added: pinout information and physical dimension drawings.

Command Definitions

Corrected the data for SecSi Sector protection in Note 9. Added device ID data to the table.

Revision A+5 (August 2, 1999)

Block Diagram

Separated WP# and ACC.

Ordering Information

Added the valid combinations for the SSOP package.

Revision A+6 (September 28, 1999)

Connection Diagrams

Clarified which packages are available for a particular part number.

Device Bus Operations

VersatileIO Control: Added comment to contact AMD for more information on this feature.

DC Characteristics

CMOS Compatible table: Added notes (1 and 2) for I_{LI} and test conditions column.

Test Conditions

In Test Specifications table and Input Waveforms and Measurement Levels figure, changed the output measurement level to $V_{IO}/2$.

AC Characteristics

Read-only Operations table: Added note for test setup column.

Revision B (June 20, 2000)

Global

Deleted references to 150 ns speed option. Added more information and specifications on V_{IO} feature, including part number distinctions. At $V_{IO} < V_{CC}$, the available speed options are 100 ns and 120 ns. At $V_{IO} \geq V_{CC}$, the available speed options are 90 ns and 120 ns. Changed data sheet status to "Preliminary."

Distinctive Characteristics

Clarified on which devices RY/BY# and WP# are available. Clarified package options for devices.

Ordering Information

Clarified on which devices RY/BY# and WP# are available. Clarified package options for devices. Reinstated "0" into the 120 ns speed part number for $V_{IO} = 3.0$ V to 5.0 V; added part numbers for $V_{IO} = 1.8$ V to 2.9 V.

Device Bus Operations table

In the legend, corrected the V_{HH} voltage range.

SecSi Sector Contents table

Corrected ending address in second row to 7Fh.

DC Characteristics table

Redefined V_{OH1} and V_{OH2} in terms of V_{IO} . Added note relative to V_{IO} for V_{IH} and V_{IL} . Deleted note regarding test condition assumption of $V_{IO} = V_{CC}$.

Test Conditions

Test Conditions table: Redefined output timing measurement reference level as $0.5 V_{IO}$.

Added note to table and figure.

Erase and Program Operations table, Alternate CE# Controlled Erase and Program Operations table, Erase and Programming Performance table

Changed the typical sector erase time to 1.6 s.

AC Characteristics—Figure 15. Program Operations Timing and Figure 17. Chip/Sector Erase Operations

Deleted t_{GHWL} and changed OE# waveform to start at high.

Physical Dimensions

Replaced figures with more detailed illustrations.

Revision B+1 (August 4, 2000)**Global**

Added trademarks for SecSi Sector.

Accelerated Program Operation (page 11), Unlock Bypass Command Sequence (page 25)

Added caution note regarding ACC pin.

Absolute Maximum Ratings

Corrected the maximum voltage on V_{IO} to +5.5V.

DC Characteristics table

Added $WP\# = V_{IH}$ to test conditions for standby currents I_{CC3} , I_{CC4} , I_{CC5} .

Revision B+2 (October 18, 2000)**Distinctive Characteristics**

Corrected package options for 56-pin SSOP as being available on Am29LV640DH/DL only.

Revision B+3 (January 18, 2001)**Global**

Deleted “Preliminary” status from document.

General Description

In the second paragraph, corrected references to V_{IO} voltage ranges. The 90 and 120 speeds are available where $V_{IO} \geq V_{CC}$, and 100 and 120 ns speeds are available where $V_{IO} < V_{CC}$.

Revision B+4 (March 8, 2001)

Table 4, Sector Group Protection/Unprotection Address Table

Corrected the sector group address bits for sectors 64–127.

Revision B+5 (October 11, 2001)

Connection Diagrams, Ordering Information, Physical Dimensions

Added 64-ball Fortified BGA package information.

Revision B+6 (January 10, 2002)**Global**

Clarified description of VersatileIO (V_{IO}) in the following sections: Distinctive Characteristics; General Description; VersatileIO (V_{IO}) Control; Operating Ranges; DC Characteristics; CMOS compatible.

Reduced typical sector erase time from 1.6 s to 0.9 s.

DC Characteristics

Changed minimum V_{OH1} from $0.85V_{IO}$ to $0.8V_{IO}$. Deleted reference to Note 6 for both V_{OH1} and V_{OH2} .

Erase and Program Performance table

Reduced typical sector erase time from 1.6 s to 0.9 s. Changed typical chip program time from 90 s to 115 s.

Revision B+7 (April 15, 2002)**Ordering Information**

Added N designator for Fortified BGA package markings.

Common Flash Interface (CFI)

Revised data value at address 44h. Clarified description of data for addresses 45–47h, 49, 4A, 4D–4Fh.

Table 10, Command Definitions

Clarified and combined Notes 4 and 5 into Note 4.

Revision B+8 (September 20, 2002)**Sector Erase Command Sequence**

Changed sentence arrangement in fourth paragraph.

Revision B+9 (March 3, 2004)**Table 10, Command Definitions**

Revised SecSi Sector Factory Protect (note 8) command definitions.

Revision B+10 (April 5, 2004)**Command Definitions**

Changed first Address data for Erase Suspend/Resume from BA to XXX.

Revision C (June 4, 2004)**Ordering Information**

Added Pb-free OPNs.

Revision C + 1 (October 14, 2004)

Ordering Information

Added t_{RH} reference line to Figure 14.

Corrected description of Sector Erase Command Sequence on page 30.

Added Colophon

Revision C + 2 (January 7, 2005)

Valid Combinations

Updated table to include a note regarding product offerings for new designs.

Revision C + 3 (February 9, 2005)

Pin Description

Added RFU to the list of pins.

Global

Removed references to byte mode.

Revision C + 4 (September 13, 2005)

Valid Combinations

New option FF added on TSOP and SSOP packages.

Revision C5 (December 23, 2005)

Global

Deleted reverse TSOP package option and 100 ns speed option.

Colophon

The products described in this document are designed, developed and manufactured as contemplated for general use, including without limitation, ordinary industrial use, general office use, personal use, and household use, but are not designed, developed and manufactured as contemplated (1) for [any use that includes](#) fatal risks or dangers that, unless extremely high safety is secured, could have a serious effect to the public, and could lead directly to death, personal injury, severe physical damage or other loss (i.e., nuclear reaction control in nuclear facility, aircraft flight control, air traffic control, mass transport control, medical life support system, missile launch control in weapon system), or (2) for [any use where chance of failure is intolerable](#) (i.e., submersible repeater and artificial satellite). Please note that Spansion LLC will not be liable to you and/or any third party for any claims or damages arising in connection with above-mentioned uses of the products. Any semiconductor devices have an inherent chance of failure. You must protect against injury, damage or loss from such failures by incorporating safety design measures into your facility and equipment such as redundancy, fire protection, and prevention of over-current levels and other abnormal operating conditions. If any products described in this document represent goods or technologies subject to certain restrictions on export under the Foreign Exchange and Foreign Trade Law of Japan, [the US Export Administration Regulations](#) or [the applicable laws of any other country](#), the prior authorization by [the respective government entity](#) will be required for export of those products.

Trademarks

Copyright ©1999-2005 Advanced Micro Devices, Inc. All rights reserved.

AMD, the AMD logo, and combinations thereof are registered trademarks of Advanced Micro Devices, Inc.

ExpressFlash is a trademark of Advanced Micro Devices, Inc.

Product names used in this publication are for identification purposes only and may be trademarks of their respective companies.

