

Am2147/Am21L47

4096x1 Static RAM

DISTINCTIVE CHARACTERISTICS

- High speed — access times down to 35 ns maximum
- Automatic power-down when deselected
- Low power dissipation
- High output drive
- TTL compatible interface levels
- No power-on current surge

GENERAL DESCRIPTION

The Am2147/Am21L47 Series are high-performance, 4096 x 1-bit, static, read/write, random-access memories. It is organized as 4096 words by one bit per word. All interface signal levels are identical to TTL specifications, providing good noise immunity and simplified system design. All inputs are purely capacitive MOS loads. The outputs will drive up to seven standard TTL loads or up to six Schottky TTL loads.

Only a single +5-volt power supply is required. When deselected ($\overline{CS} \geq V_{IH}$), the Am2147 automatically enters a

power-down mode which reduces power dissipation by more than 85%. When selected, the chip powers up again with no access time penalty.

Data In and Data Out use separate pins on the standard 18-pin package. Data Out is the same polarity as Data In. Data Out is a three-state signal allowing wired-or operation of several chips. Data In and Data Out may be connected together for operation in a common data bus environment.

BLOCK DIAGRAM

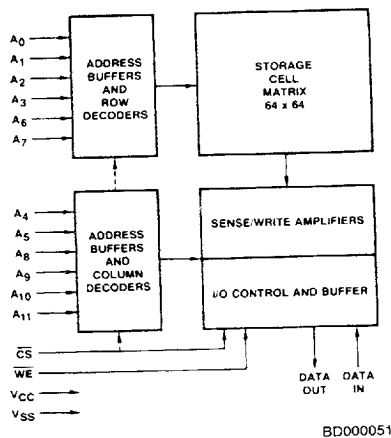

PRODUCT SELECTOR GUIDE

Part Number	Am2147-35	Am2147-45	Am21L47-45	Am2147-55	Am21L47-55	Am2147-70	Am21L47-70
Maximum Access time (ns)	35	45	45	55	55	70	70
Maximum Active Current (mA)	180	180	125	180	125	160 (180 mil)	125
Maximum Standby Current (mA)	30	30	15	30	15	20 (30 mil)	15
Full Military Operating Range Version		Yes		Yes		Yes	

8077984 0000027 334

CONNECTION DIAGRAMS Top View

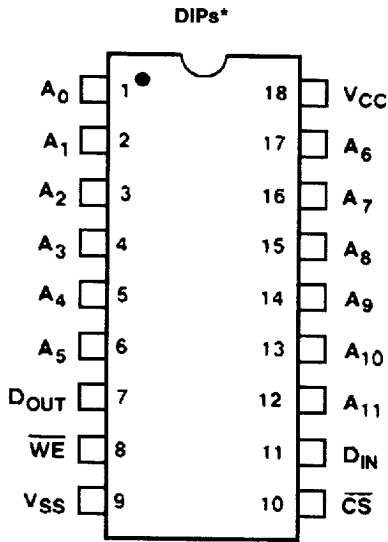

CD000091

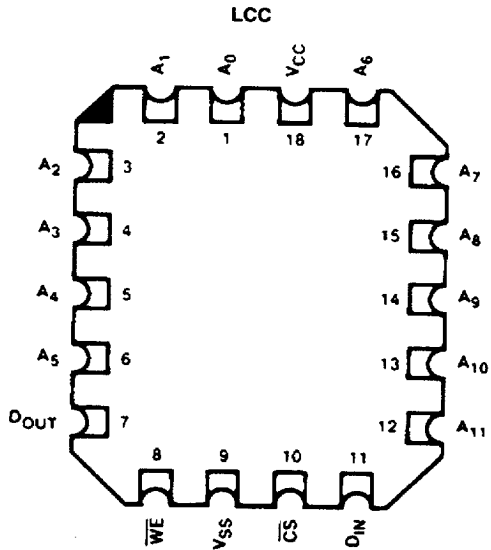

CD000100

*Also available for military customers in an 18-Pin Ceramic Flatpack. Pinout is identical to DIPs.

Note: Pin 1 is marked for orientation.

BIT MAP

Address Designators	
External	Internal
A ₀	A ₂
A ₁	A ₅
A ₂	A ₄
A ₃	A ₃
A ₄	A ₈
A ₅	A ₇
A ₆	A ₁
A ₇	A ₀
A ₈	A ₁₁
A ₉	A ₉
A ₁₀	A ₁₀
A ₁₁	A ₆

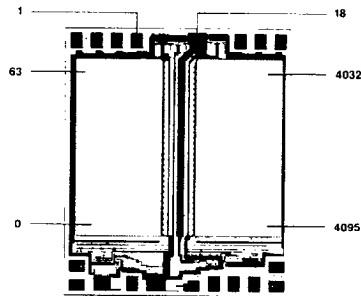

Die Size: 0.130 x 0.106

■ 8077984 0000028 270 ■

ORDERING INFORMATION

Standard Products

AMD standard products are available in several packages and operating ranges. The order number (Valid Combination) is formed by a combination of:

- a. **Device Number**
- b. **Speed Option** (if applicable)
- c. **Package Type**
- d. **Temperature Range**
- e. **Optional Processing**

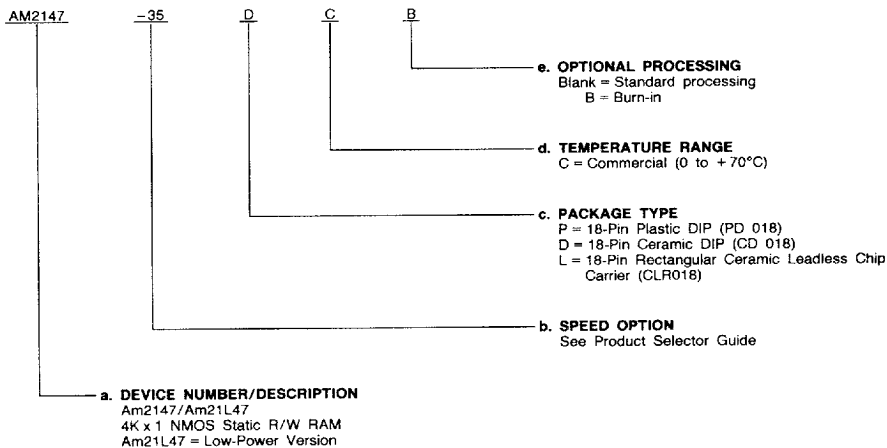

Valid Combinations	
AM2147-35	PC, PCB, DC, DCB, LC, LCB
AM2147-45	
AM2147-55	
AM2147-70	
AM21L47-45	
AM21L47-55	
AM21L47-70	

Valid Combinations

Valid Combinations list configurations planned to be supported in volume for this device. Consult MSIS sales department to confirm availability of specific valid combinations, and to obtain additional data on MSIS's standard military grade products.

8077984 0000029 107

MILITARY ORDERING INFORMATION

APL Products

AMD products for Aerospace and Defense applications are available in several packages and operating ranges. APL (Approved Products List) products are fully compliant with MIL-STD-883C requirements. The order number (Valid Combination) is formed by a combination of:

- a. Device Number
- b. Speed Option (if applicable)
- c. Device Class
- d. Package Type
- e. Lead Finish

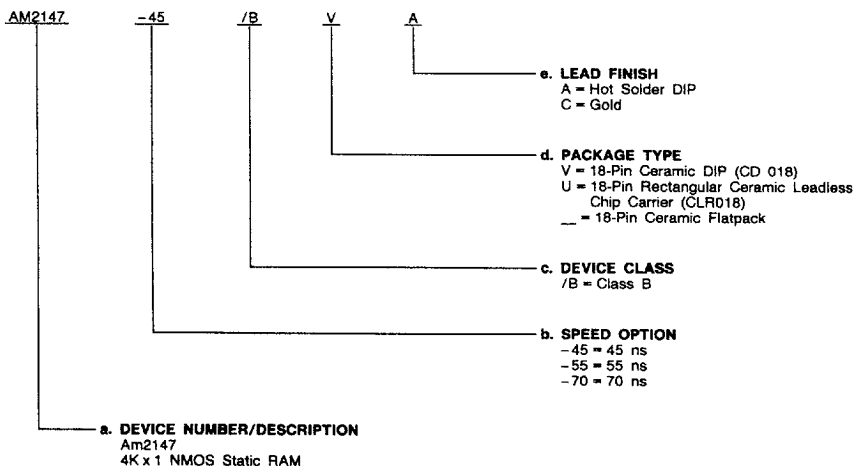

Valid Combinations	
AM2147-45	/BVA
AM2147-55	
AM2147-70	
AM2147-45	/BUC
AM2147-55	
AM2147-70	

Valid Combinations

Valid Combinations list configurations planned to be supported in volume for this device. Consult MSIS sales department to confirm availability of specific valid combinations, and to obtain additional data on MSIS's standard military grade products.

Group A Tests

Group A tests consist of Subgroups
1, 2, 3, 7, 8, 9, 10, 11.

PIN DESCRIPTION

A₀ - A₁₁ Address Inputs

The address input lines select the RAM location to be read or written.

CS Chip Select (Input, Active LOW)

The Chip Select selects the memory device.

WE Write Enable (Input, Active LOW)

When WE is LOW and CS is also LOW, data is written into the location specified on the address pins.

D_{IN} Data In (Input)

This pin is used for entering data during write operations.

D_{OUT} Data Out (Output, Three-State)

This pin is three state during write operations. It becomes active when CS is LOW and WE is HIGH.

V_{CC} Power Supply

V_{SS} Ground

■ 8077984 0000030 929 ■

ABSOLUTE MAXIMUM RATINGS

Storage Temperature	-65 to +150°C
Ambient Temperature with Power Applied	-55 to +125°C
Supply Voltage	-0.5 V to +7.0 V
Signal Voltages with respect to ground	-3.5 V to +7.0 V
Power Dissipation	1.2 W
DC Output Current	20. mA

Stresses above those listed under ABSOLUTE MAXIMUM RATINGS may cause permanent device failure. Functionality at or above these limits is not implied. Exposure to absolute maximum ratings for extended periods may affect device reliability.

Absolute Maximum Ratings are for system-design reference; parameters given are not 100% tested.

DC CHARACTERISTICS over operating ranges unless otherwise specified (for APL Products, Group A, Subgroups 1, 2, 3 are tested unless otherwise noted)

OPERATING RANGES

Commercial (C) Devices	
Ambient Temperature (T _A)	0 to +70°C
Supply Voltage (V _{CC})	+4.5 V to +5.5 V
Military (M) Devices	
Ambient Temperature (T _A)*	-55 to +125°C
Supply Voltage V _{CC}	+4.5 V to +5.5 V

Operating ranges define those limits between which the functionality of the device is guaranteed.

*T_A is defined as the "instant on" case temperature.

Parameter Symbol	Parameter Description	Test Conditions		Am2147-35 Am2147-45 Am2147-55		Am21L47-45 Am21L47-55 Am21L47-70		Am2147-70		Unit
				Min.	Max.	Min.	Max.	Min.	Max.	
I _{OH}	Output High Current	V _{OH} = 2.4 V	V _{CC} = 4.5 V	-4		-4		-4		mA
I _{OL}	Output Low Current	V _{OL} = 0.4 V	T _A = 70°C T _A = 125°C	12		12		12		mA
V _{IH}	Input High Voltage			2.0	6.0	2.0	6.0	2.0	6.0	V
V _{IL}	Input Low Voltage			-2.5	0.8	-2.5	0.8	-2.5	0.8	V
I _{Ix}	Input Load Current	V _{SS} ≤ V _I ≤ V _{CC}		-10	10	-10	10	-10	10	μA
I _{OZ}	Output Leakage Current	GND ≤ V _O ≤ V _{CC} Output Disables	T _A = -55 to +125°C	-50	50	-50	50	-50	50	μA
C _I	Input Capacitance	Test Frequency = 1.0 MHz (Note 4)			5		5		5	pF
C _O	Output Capacitance	T _A = 25°C, All pins at 0 V, V _{CC} = 5 V			6		6		6	pF
I _{CC}	V _{CC} Operating Supply Current	Max. V _{CC} CS ≤ V _{IL} Output Open	T _A = 0 to 70°C T _A = -55 to 125°C		180		125		180	mA
I _{SB}	Automatic CS Power Down Current	Max. V _{CC} , (CS ≥ V _{IH}) (Note 3)	T _A = 0 to 70°C T _A = -55 to +125°C		30		15		20	mA

- Notes: 1. Test conditions assume signal transition times of 10 ns or less, timing reference levels of 1.5 V, input pulse levels of 0 to 3.0 V and output loading of the specified I_{OL}/I_{OH} and 30 pF load capacitance. Output timing reference is 1.5 V.
 2. The internal write time of the memory is defined by the overlap of CS LOW and WE LOW. Both signals must be low to initiate a write and either signal can terminate a write by going HIGH. The data input setup and hold timing should be referenced to the rising edge of the signal that terminates the write.
 3. A pull-up resistor to V_{CC} on the CS input is required to keep the device deselected during V_{CC} power up. Otherwise I_{SB} will exceed values given.
 4. These parameters are not 100% tested, but guaranteed by characterization.
 5. Chip deselected greater than 55 ns prior to selection.
 6. Chip deselected less than 55 ns prior to selection.
 7. Transition is measured at 1.5 V on the input to V_{OH} = 500 mV and V_{OL} = 500 mV on the outputs using the load shown in Figure B under Switching Test Circuit.
 8. WE is HIGH for read cycle.
 9. Device is continuously selected, CS = V_{IL}.
 10. Address valid prior to or coincident with CS transition LOW.

8077984 0000031 865

SWITCHING CHARACTERISTICS

over operating ranges unless otherwise specified (Note 1) (for APL Products, Group A, Subgroups 9, 10, 11 are tested unless otherwise noted)

No.	Parameter Symbol	Parameter Description	Am2147-35		Am2147-45 Am21L47-45		Am2147-55 Am21L47-55		Am2147-70 Am21L47-70		Unit
			Min.	Max.	Min.	Max.	Min.	Max.	Min.	Max.	
READ CYCLE											
1	t_{RC}	Address Valid to Address Do Not Care Time (Read Cycle Time)	35		45		55		70		ns
2	t_{AA}	Address Valid to Data Out Valid Delay (Address Access Time)		35		45		55		70	ns
3	t_{ACS1}	Chip Select LOW to Data Out Valid		35		45		55		70	ns
4	t_{ACS2}			35		45		65		80	
5	t_{LZ}	Chip Select LOW to Data Out On (Notes 4 & 7)	5		5		5		5		ns
6	t_{HZ}	Chip Select HIGH to Data Out Off (Notes 4 & 7)	0	30	0	30	0	30	0	40	ns
7	t_{OH}	Output hold after address change	5		5		5		5		ns
8	t_{PD}	Chip Select HIGH Power Down Delay (Note 4)		20		20		20		30	ns
9	t_{PU}	Chip Select LOW to Power Up Delay (Note 4)	0		0		0		0		ns
WRITE CYCLE											
10	t_{WC}	Address Valid to Address Do Not Care (Write Cycle Time)	35		45		55		70		ns
11	t_{WP}	Write Enable LOW to Write Enable High (Note 2)	20		25		25		40		ns
12	t_{WR}	Write Enable HIGH to Address	0		0		10		15		ns
13	t_{WZ}	Write Enable LOW to Output in Hi Z (Notes 4 & 7)	0	20	0	25	0	25	0	35	ns
14	t_{DW}	Data In Valid to Write Enable HIGH	20		25		25		30		ns
15	t_{DH}	Data Hold Time	10		10		10		10		ns
16	t_{AS}	Address Valid to Write Enable LOW	0		0		0		0		ns
17	t_{CW}	Chip Select LOW to Write Enable HIGH (Note 2)	35		45		45		55		ns
18	t_{OW}	Write Enable HIGH to Output in Low Z (Notes 4 & 7)	0		0		0		0		ns
19	t_{AW}	Address Valid to End of Write	35		45		45		55		ns

Notes: See notes following DC Characteristics table.

SWITCHING TEST CIRCUITS

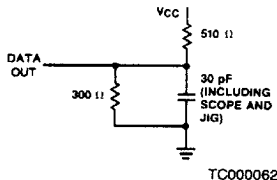

A. Output Load

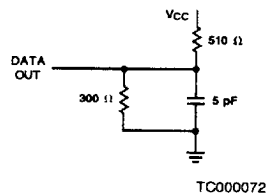

B. Output Load
for t_{HZ} , t_{LZ} , t_{OW} , t_{wZ}

8077984 0000032 7T1

SWITCHING WAVEFORMS

KEY TO SWITCHING WAVEFORMS

WAVEFORM	INPUTS	OUTPUTS
	MUST BE STEADY	WILL BE STEADY
	MAY CHANGE FROM H TO L	WILL BE CHANGING FROM H TO L
	MAY CHANGE FROM L TO H	WILL BE CHANGING FROM L TO H
	DON'T CARE; ANY CHANGE PERMITTED	CHANGING; STATE UNKNOWN
	DOES NOT APPLY	CENTER LINE IS HIGH IMPEDANCE "OFF" STATE

KS000010

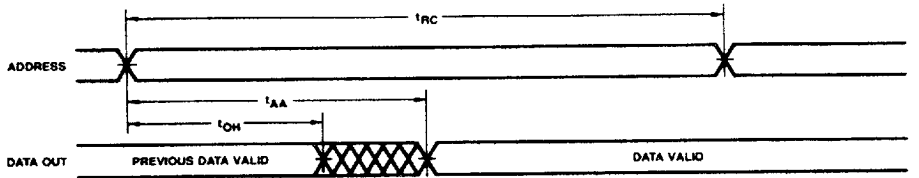

WF000461

Read Cycle No. 1 (Notes 8, 9)

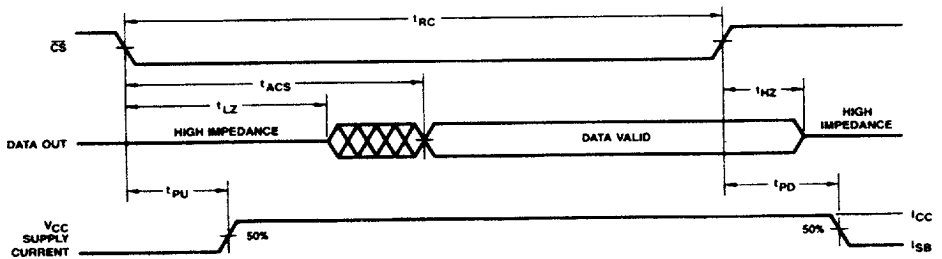

WF000471

Read Cycle No. 2 (Notes 8, 10)

Notes: See notes following DC Characteristics table.

8077984 0000033 638

SWITCHING WAVEFORMS (Cont'd.)

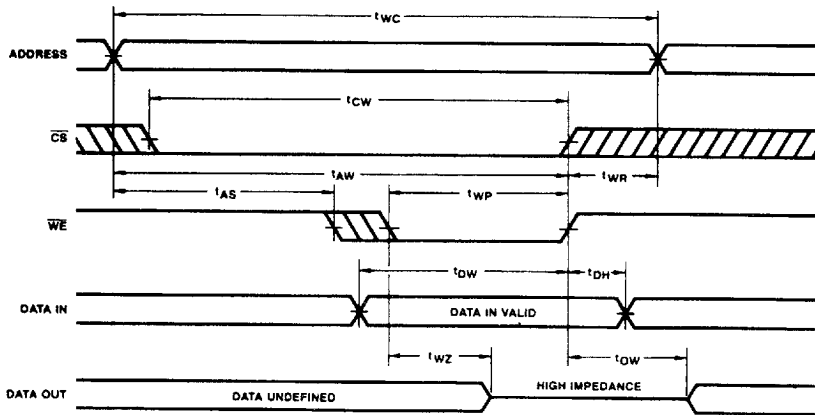

WF00021

Write Cycle No. 1 (\overline{WE} Controlled)

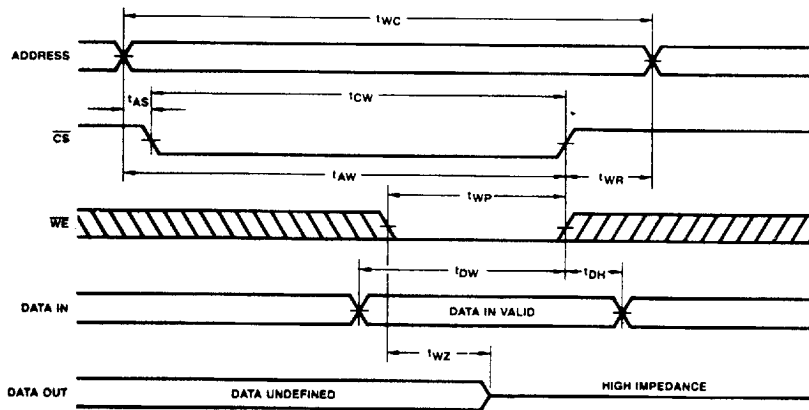

WF00021

Write Cycle No. 2 (\overline{CS} Controlled)

Note: If \overline{CS} goes HIGH simultaneously with \overline{WE} high, the output remains in a high impedance state.

8077984 0000034 574

TYPICAL PERFORMANCE CURVES

**Supply Current
Versus Supply Voltage**

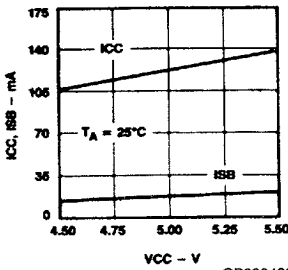

OP000430

**Supply Current
Versus Ambient Temperature**

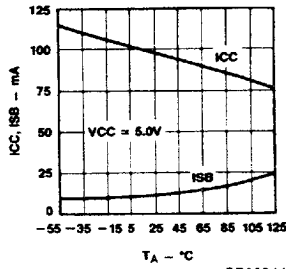

OP000440

**Output Source Current
Versus Output Voltage**

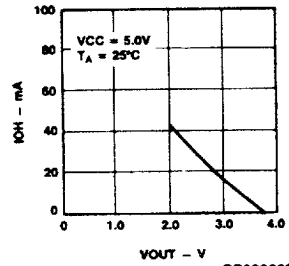

OP000220

**Normalized Access Time
Versus Supply Voltage**

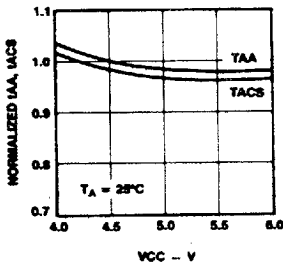

OP000760

**Normalized Access Time
Versus Ambient Temperature**

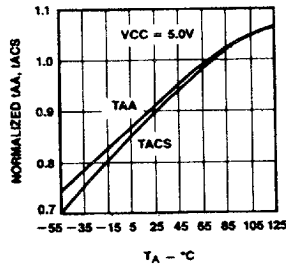

OP000230

**Output Sink Current
Versus Output Voltage**

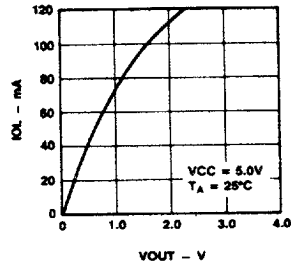

OP000240

**Typical Power-On Current
Versus Power Supply**

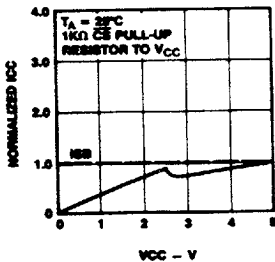

OP000870

**Access Time Change
Versus Input Voltage**

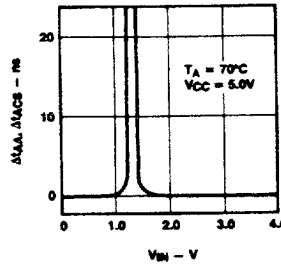

OP000800

**Access Time Change
Versus Output Loading**

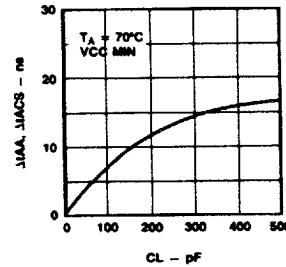

OP000270

8077984 0000035 400

Am2148/Am2149/Am2148L/Am2149L

