

**Surface Mount Load Dump
Transient Voltage Suppressors**

**REVERSE VOLTAGE – 10~43 Volts
PEAK PULSE POWER – 6600 Watt**

FEATURES



- High current capability
- Low Forward Voltage Drop
- Low reverse current
- Low thermal resistance
- Excellent high temperature stability
- Low power loss and high efficiency
- High forward surge capability
- Meet ISO7637-2 and ISO16750-2 surge specification (varied by test condition)
- Meet MSL level 1, per J-STD-020, LF maximum peak of 260 °C
- AEC-Q101 qualified
- PPAP capable
- Automotive grade

APPLICATION

- High peak power
- High-temperature
- Clamping diode
- Load switching and lighting
- Use in sensitive electronics protection against voltage transients induced by inductive automotive ECU module, especially for automotive load dump protection application

MECHANICAL DATA

- **Case:** DO-218 outline plastic package
- **Terminals:** Matte tin plated, solderable per MIL-STD-750, Method 2026, J-STD-002 and JESD 22-B102
- Molding Compound Flammability Rating:UL94-0
- High temperature soldering guaranteed: 260°C/10second
- **Polarity:** Heatsink is anode
- Corresponds to taping packages. (700PCS/Reel)

DO-218

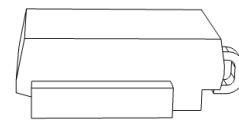
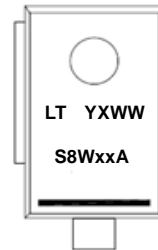
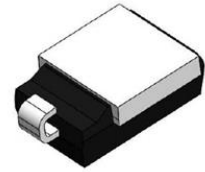
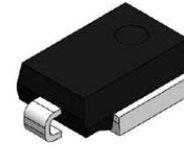

Primary Characteristics

VWM	10 V to 43 V
VBR	11.1 V to 52.8 V
PPPM (10 x 1000 uS)	6600 W
PPPM (10 x 10 000 uS)	5200 W
IFSM	700 A
Polarity	Uni-directional
Diode variation	Single

REV. 4, Oct-2017, KSIB06

Please be aware that an **Important Notice and Disclaimer** concerning availability, disclaimers, and use in critical applications of LSC products thereto appears at the end of this Data Sheet.

Maximum Ratings (TA = 25 °C unless otherwise noted)

Parameter	Symbol	Value	Units
Peak pulse power dissipation	PPPM	6600	W
		5200	
Peak forward surge current 8.3 ms single half sine-wave	IFSM	700	A
Operating junction and storage temperature range	TJ, TSTG	-55 to +175	°C

Electrical Characteristics (TA = 25 °C unless otherwise noted)

Part Number	Breakdown Voltage V _{BR} (V)		Test Current I _T (mA)	Stand-OFF Voltage V _{WM} (V)	Maximum Reverse Leakage at V _{WM} I _D (uA)	Maximum Leakage at V _{WM} T _J = 175 °C I _D (uA)	Max. Peak Pulse Current at 10/1000 us Waveform (A)	Maximum Clamping Voltage at I _{PPM} V _C (V)
	Min.	Max.						
ALS8W10A	11.1	12.3	5.0	10.0	15	250	388	17.0
ALS8W11A	12.2	13.5	5.0	11.0	10	150	363	18.2
ALS8W12A	13.3	14.7	5.0	12.0	10	150	332	19.9
ALS8W13A	14.4	15.9	5.0	13.0	10	150	307	21.5
ALS8W14A	15.6	17.2	5.0	14.0	10	150	284	23.2
ALS8W15A	16.7	18.5	5.0	15.0	10	150	270	24.4
ALS8W16A	17.8	19.7	5.0	16.0	10	150	254	26.0
ALS8W17A	18.9	20.9	5.0	17.0	10	150	239	27.6
ALS8W18A	20.0	22.1	5.0	18.0	10	150	226	29.2
ALS8W20A	22.2	24.5	5.0	20.0	10	150	204	32.4
ALS8W22A	24.4	26.9	5.0	22.0	10	150	186	35.5
ALS8W24A	26.7	29.5	5.0	24.0	10	150	170	38.9
ALS8W26A	28.9	31.9	5.0	26.0	10	150	157	42.1
ALS8W28A	31.1	34.4	5.0	28.0	10	150	145	45.4
ALS8W30A	33.3	36.8	5.0	30.0	10	150	136	48.4
ALS8W33A	36.7	40.6	5.0	33.0	10	150	124	53.3
ALS8W36A	40.0	44.2	5.0	36.0	10	150	114	58.1
ALS8W40A	44.4	49.1	5.0	40.0	10	150	102	64.5
ALS8W43A	47.8	52.8	5.0	43.0	10	150	95.1	69.4

Note: 1. For all types maximum VF = 1.8 V at IF = 100 A measured on 8.3 ms single half sine-wave.

RATING AND CHARACTERISTIC CURVES ALS8WxxA Series

FIG.1- Power Derating Curve

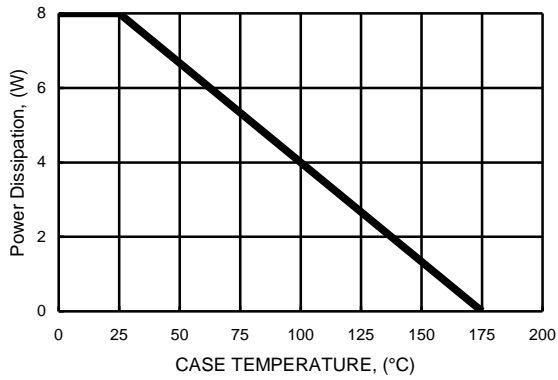

FIG.2- Load Dump Power Characteristics
(10ms Exponential Waveform)

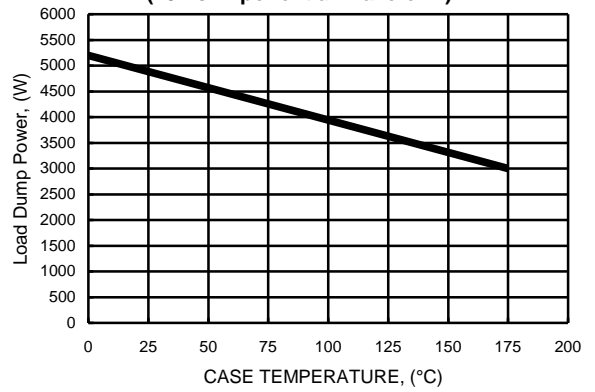

Fig.3 - Pulse Waveform

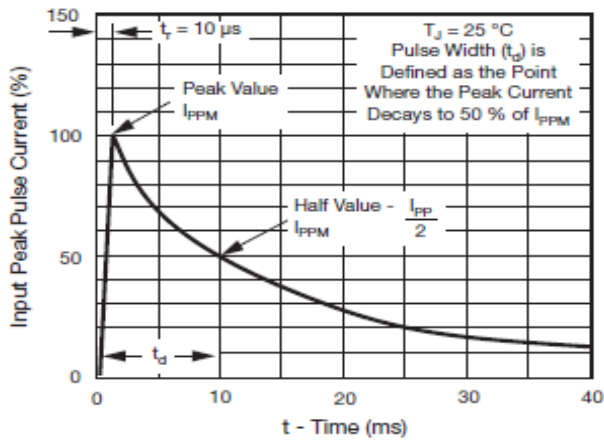

FIG.4- Reverse Power Capability



FIG.5- Typical Transient Thermal Impedance

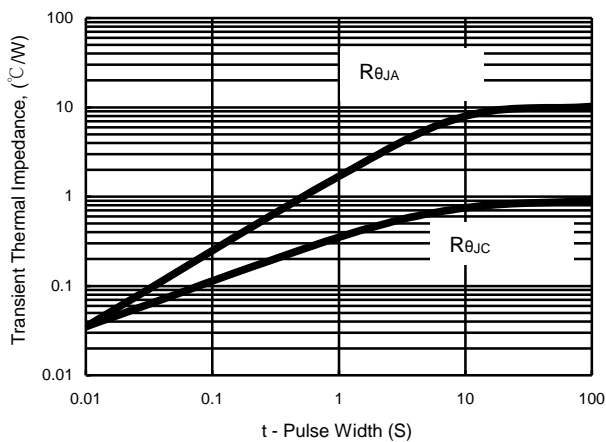
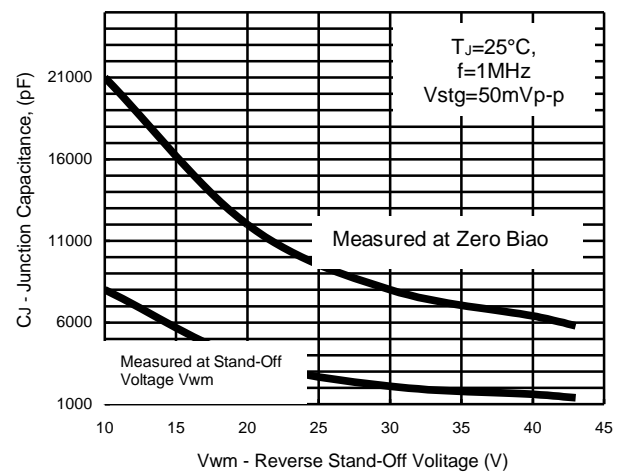
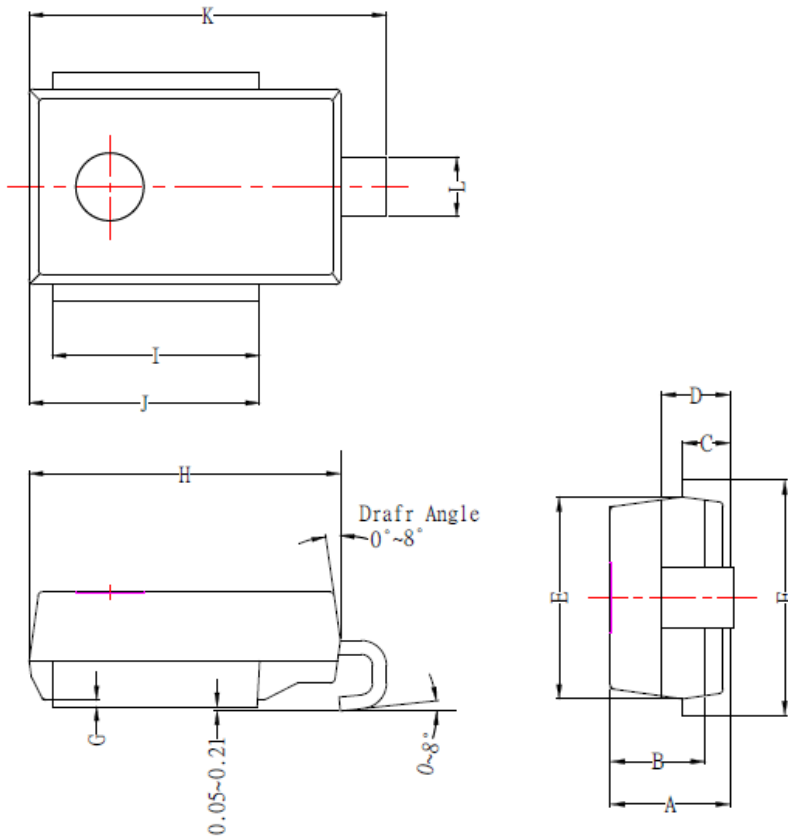

FIG.6- Typical Junction Capacitance



Package Dimension :



D0-218			
DIM.	MIN.	TYP.	MAX.
A	4.75	5.00	5.25
B	3.66	3.96	4.26
C	1.80	2.00	2.20
D	2.58	2.88	3.18
E	8.20	8.50	8.80
F	9.50	—	10.50
G	—	0.30	—
H	13.20	13.50	13.80
I	8.70	9.00	9.30
J	9.70	10.00	10.25
K	15.00	15.50	16.00
L	2.30	—	3.00
All Dimension in millimeter			

Soldering Pad Layout :

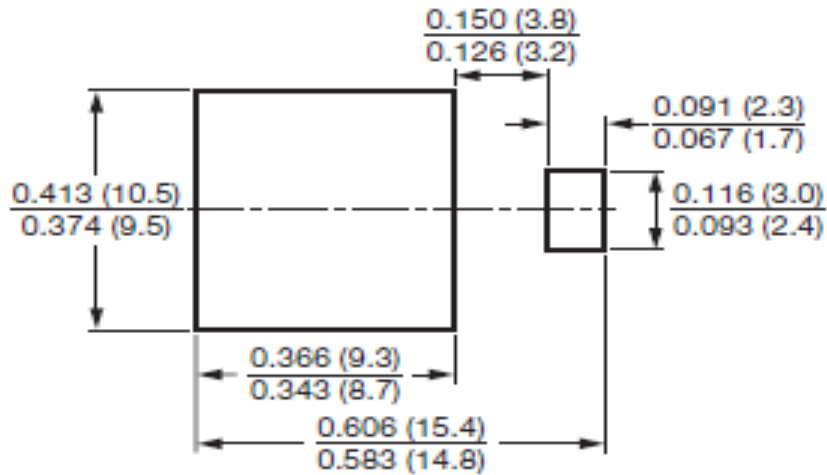

MARKING AND PACKAGING INFORMATION
ALSW8WxxA Series



Marking Information :

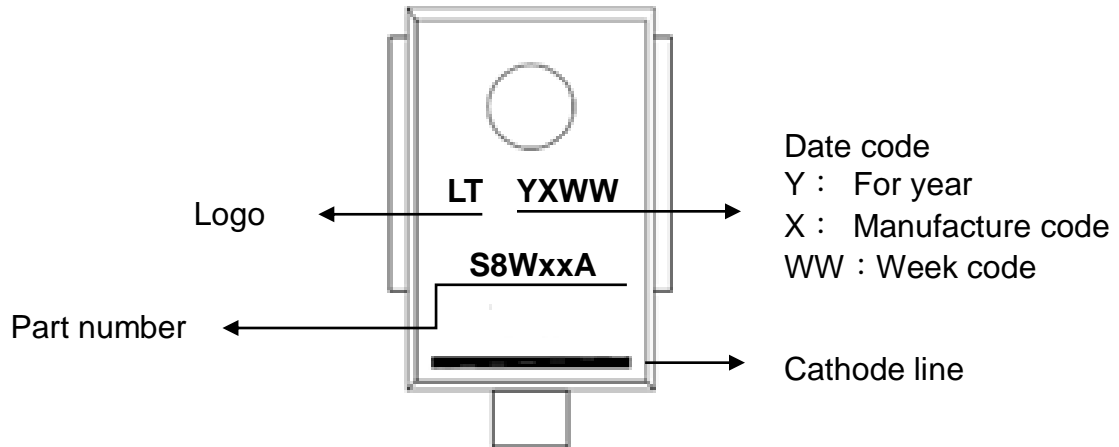

Packaging Information :

DEVICE	REEL DIA.	Q'TY/REEL	REEL/BOX	Q'TY/BOX	BOX/CORTON	Q'TY/CORTON	BOX SIZE	CARTON SIZE
	(INCH)	(PCS)	(REEL)	(PCS)	(BOX)	(PCS)	(mm)	(mm)
ALS8WxxA	13	700	1	700	7	4900	345*355*43	355*346*376

IMPORTANT NOTICE AND DISCLAIMER

LSC reserves the right to make changes to this document and its products and specifications at any time without notice. Customers should obtain and confirm the latest product information and specifications before final design purchase or use.

ALL INFORMATION ARE PROVIDED AS-IS, EVEN IT HAS QUALIFIED BY THE AEC-Q101 WHICH SATISFY INDUSTRIAL APPLICATION REQUIREMENT, EXCEPT AS EXPRESSLY STATED IN THIS DATA SHEET IS APPLIED FOR AUTOMOTIVE GRADE, LSC MAKE NO WARRANTIES, REPRESENTATION OR GUARANTEE, WHETHER EXPRESS, IMPLIED OR STATUTORY, INCLUDING, WITHOUT LIMITATION, REGARDING ANY MERCHANTABILITY, SATISFACTORY QUALITY, OR FITNESS FOR A PARTICULAR PURPOSE WITH RESPECT TO THE LSC TECHNOLOGY.

LSC DOES NOT ASSUME ANY LIABILITY OR COMPENSATION FOR ANY APPLICATION ASSISTANCE OR CUSTOMER PRODUCT DESIGN, AND MAKE NO WARRANTY OR ACCEPT ANY LIABILITY WITH PRODUCTS, WHICH ARE PURCHASED OR USED FOR ANY UNINTENDED OR UNAUTHORIZED APPLICATION.

No license is granted by implication or otherwise under any intellectual property rights of LSC.

LSC products are not authorized for use as critical components in life support devices or systems without express written approval of LSC.