

ALS30A473DF025

ALS30, Aluminum, Aluminum Electrolytic, 47000 uF, 20%, 25 VDC, -40/+85°C

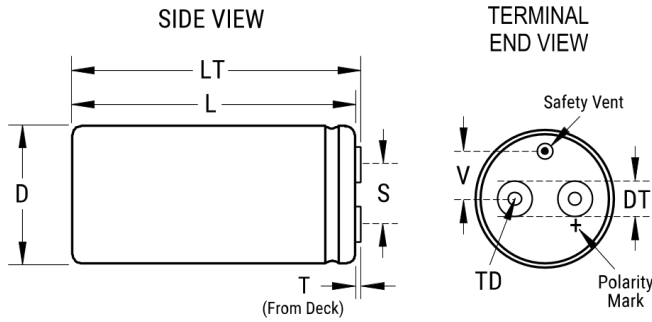

General Information	
Series	ALS30
Dielectric	Aluminum Electrolytic
Style	Screw Terminal
Description	Screw Terminal, Aluminum Electrolytic
RoHS	Yes
Lead	Screw Terminals M5
Mounting	Through-Hole
AEC-Q200	No
Typical Component Weight	140 g
Notes	Dimensions D And L Include Sleevings. MS (MxH) = M8x12. Mounting Clamp (Sold Separately): V3/H2/2736
Shelf Life	156 Weeks

Click [here](#) for the 3D model.

Dimensions	
D	36mm +/-1mm
L	105mm +/-2mm
T	7.1mm +/-0.5mm
S	12.8mm +/-0.5mm
DT	8mm +/-0.5mm
LT	111.5mm +/-1mm
TD	10mm MIN
V	8mm NOM

Packaging Specifications	
Sleevings	true
Packaging	Bulk, Box

Specifications	
Capacitance	47000 uF
Capacitance Tolerance	20%
Voltage DC	25 VDC, 28.75 VDC (Surge)
Temperature Range	-40/+85°C
Rated Temperature	85°C
Life	11000 Hrs (Rated Voltage And Ripple Current At 85C), 22000 Hrs (Rated Voltage At 85C)
ESR	9 mOhms (100Hz 20C), 7 mOhms (10kHz 20C)
Ripple Current	16.6 Amps (100Hz 85C), 17.4 Amps (10kHz 85C)
Leakage Current	6000 uA (5min 20°C)

Statements of suitability for certain applications are based on our knowledge of typical operating conditions for such applications, but are not intended to constitute - and we specifically disclaim - any warranty concerning suitability for a specific customer application or use. This information is intended for use only by customers who have the requisite experience and capability to determine the correct products for their application. Any technical advice inferred from this information or otherwise provided by us with reference to the use of our products is given gratis, and we assume no obligation or liability for the advice given or results obtained.