

REVISIONS					
REV	ECO	DESCRIPTION	DATE	BY	APPR
A1	--	RELEASE NEW DRAWING	26DEC17	RIMON	TOMMY
A2	C0870S	Change the appearance of the retaining ring	27JUN18	KASOON	TOMMY

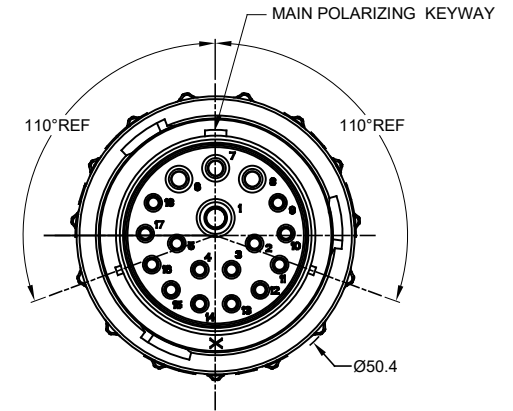
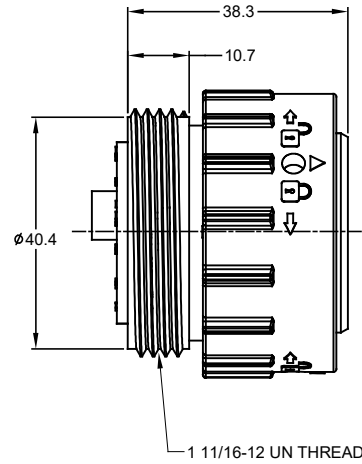
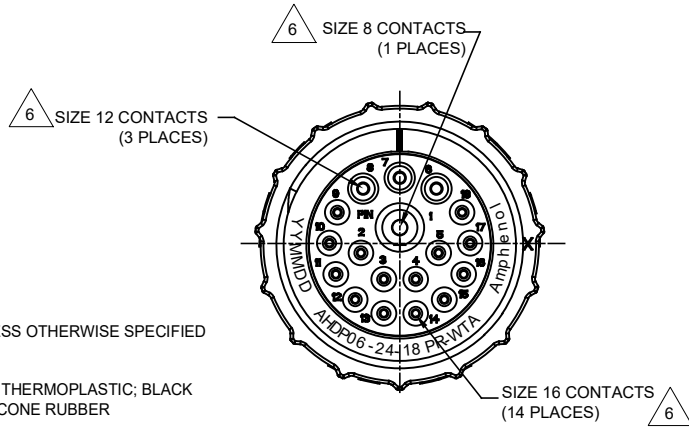

NOTES: UNLESS OTHERWISE SPECIFIED

- MATERIAL:  
HOUSING: THERMOPLASTIC; BLACK  
SEAL: SILICONE RUBBER
- MODIFICATIONS: THREADED ADAPTER;  
REDUCED DIA. WIRE SEAL
- SPECIFICATIONS:
  - OPERATING TEMPERATURE: -55°C ~ +125°C.
  - DIELECTRIC WITHSTANDING VOLTAGE: LESS THAN 2 MILLIAMPS CURRENT LEAKAGE @ 1500 VOLTS AC.
  - INSULATION RESISTANCE: 1000 MEGOHM MIN 25°C.
  - MOISTURE RESISTANCE: IP67&IP69K ( MATED CONDITION ).
  - MATING CYCLE DURABILITY: 100 CYCLES
  - RoHS COMPLIANT
- MATING PART: AHP04-24-18S\* (\* = SEAL TYPE )
- ALL DIMENSIONS ARE FOR REFERENCE USE ONLY.

6 CONTACT SIZE AND WIRE RANGE:

CONTACT SIZE	MIN. INSUL O.D.	MAX. INSUL O.D.	TYPICAL WIRE RANGE	CURRENT RATING
08	3.43 mm (.135in)	5.59 mm (.220 in)	8-10 AWG	60 AMPS
12	2.46 mm (.097 in)	4.01 mm (.158 in)	10-14 AWG	25 AMPS
16	1.35 mm (.053in)	3.05 mm (.120 in)	14-20 AWG	13 AMPS

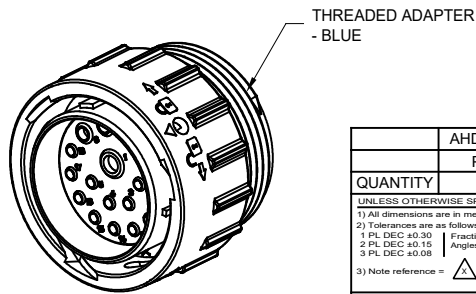

AHP06-24-18PR-WTA		DESCRIPTION	
QUANTITY	PART NUMBER	DESCRIPTION	ITEM
<b>MATERIALS LIST</b>			
UNLESS OTHERWISE SPECIFIED: 1) All dimensions are in metric (mm). 2) Tolerances are as follows: 1 PL DEC $\pm 0.30$ 2 PL DEC $\pm 0.15$ 3 PL DEC $\pm 0.08$ 3) Note reference =		SIGNATURES	DATE
		DRAWN: KASOON	27JUN18
		CHECKED: ORIONLI	27JUN18
		ENGINEER:	
		APPROVAL: TOMMY XIE	27JUN18
MATERIAL SPECIFICATIONS:		CUSTOMER:	
PROCESS SPECIFICATIONS:		THIS DRAWING IS SUPPLIED FOR INFORMATION ONLY. DESIGN FEATURES, SPECIFICATIONS AND PERFORMANCE DATA SHOWN HEREON ARE THE PROPERTY OF THE AMPHENOL CORPORATION. NO RIGHTS OF REPRODUCTION ARE IMPLIED. ALL DIMENSIONS ARE SUBJECT TO NORMAL MANUFACTURING VARIATIONS.	
NEXT ASSY:		SIZE	TYPE
		B	C-
		SCALE	NONE
		DWG NO:	AHP06-24-18PR-WTA
		REVISION	A2
		PLUG, 24-18 POS. PIN CONTACT REDUCED DIA. SEAL, AHPD SERIES	
		SHEET 1 OF 1	

TITLE: PLUG, 24-18 POS. PIN CONTACT REDUCED DIA. SEAL, AHPD  
DWG NO: AHPD06-24-18PR-WTA  
REV: A2  
SH: 1  
OF: 1