

**NOTES: UNLESS OTHERWISE SPECIFIED**

- MATERIAL:**  
HOUSING: THERMOPLASTIC; BLACK  
SEAL: SILICONE RUBBER
- MODIFICATIONS:** THREADED ADAPTER;  
REDUCED DIA. WIRE SEAL

- SPECIFICATIONS:**
  - OPERATING TEMPERATURE: -55°C TO +125°C.
  - DIELECTRIC WITHSTANDING VOLTAGE: LESS THAN 2 MILLIAMPS CURRENT LEAKAGE @ 1500 VOLTS AC.
  - INSULATION RESISTANCE: 1000 MEGOHM MIN @ 25°C.
  - MOISTURE RESISTANCE: IP67&IP69K ( MATED CONDITION ).
  - MATING CYCLE DURABILITY: 100 CYCLES
  - RoHS COMPLIANT

4. MATING PART: AHDP06-24-29P\* (\* = SEAL TYPE )

5. ALL DIMENSIONS ARE FOR REFERENCE USE ONLY.

**6 CONTACT SIZE AND WIRE RANGE:**

CONTACT SIZE	MIN. INSUL O.D.	MAX. INSUL O.D.	TYPICAL WIRE RANGE	CURRENT RATING
20	1.02 mm (.040 in)	2.10 mm (.083 in)	16-22 AWG	7.5 AMPS
16	1.35 mm (.053in)	2.62 mm (.103 in)	14-20 AWG	13 AMPS
12	2.46 mm (.097 in)	4.01 mm (.158 in)	10-14 AWG	25 AMPS

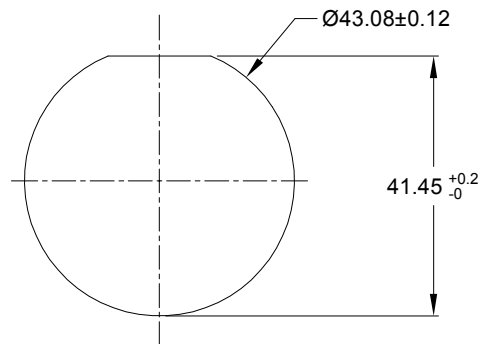
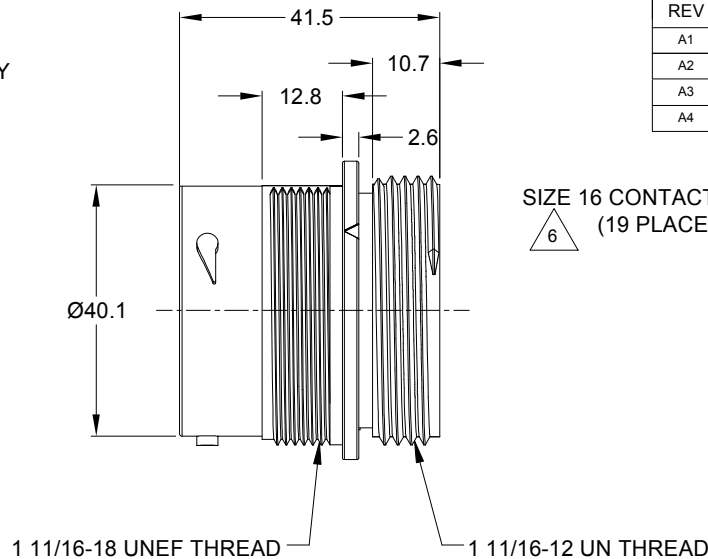

RECOMMENDED PANEL MOUNTING HOLE

RECOMMENDED PANEL THICKNESS: 1.6 TO 4.7MM

REVISIONS					
REV	ECO	DESCRIPTION	DATE	BY	APPR
A1		RELEASE NEW DRAWING	13NOV15	SULLEN	TOMMY
A2	C0765S	UPDATE SPECIFICATIONS	23NOV17	ROOKIE	TOMMY
A3	C0870S	Change the appearance of the retaining ring	26JUN18	KASOON	TOMMY
A4	C1001S	CHANGE THE WIRE SIZE	28DEC18	BROOK	TOMMY

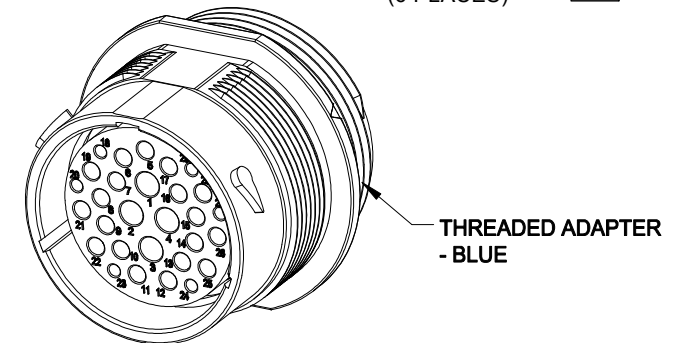
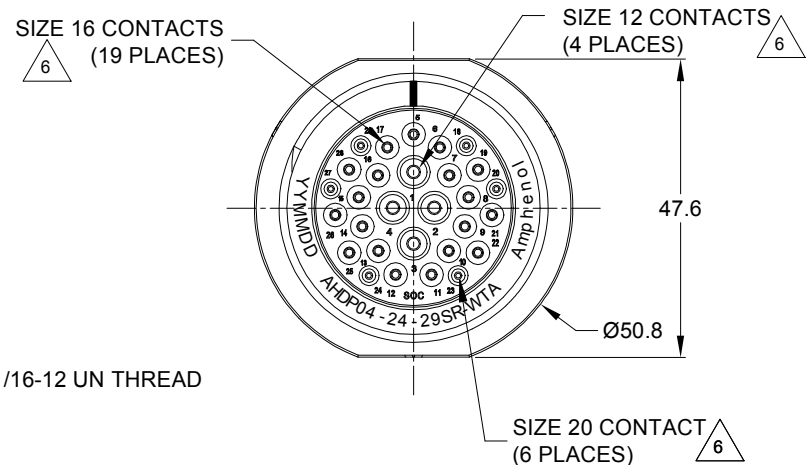

AHDPO4-24-29SR-WTA		PART NUMBER		DESCRIPTION		ITEM
QUANTITY		<b>MATERIALS LIST</b>				
UNLESS OTHERWISE SPECIFIED		SIGNATURES		DATE		<p><b>Amphenol</b></p> <p>Sine Systems - www.amphenol-sine.com 44724 Morley Drive Clinton Township, MI 48036</p> <p>RECEP., 24-29 POS, SOCKET CONTACT REDUCED DIA. SEAL, AHDP SERIES</p>
1) All dimensions are in metric(mm).		DRAWN: BROOK		28DEC18		
2) Tolerances are as follows:		CHECKED: ORION		28DEC18		
1 PL DEC ±0.30 Fractions ±1/64		ENGINEER:				
2 PL DEC ±0.15		APPROVAL: TOMMY		28DEC18		<p>SIZE TYPE DWG NO: <b>B C-</b> <b>AHDPO4-24-29SR-WTA</b> <b>A4</b></p> <p>SCALE: NONE SHEET 1 OF 1</p>
3) Note reference =		CUSTOMER:				
MATERIAL SPECIFICATIONS:		THIS DRAWING IS SUPPLIED FOR INFORMATION ONLY. DESIGN FEATURES, SPECIFICATIONS AND PERFORMANCE DATA SHOWN HEREON ARE THE PROPERTY OF THE AMPHENOL CORPORATION. NO RIGHTS OF REPRODUCTION ARE IMPLIED. ALL DIMENSIONS ARE SUBJECT TO NORMAL MANUFACTURING VARIATIONS.				
PROCESS SPECIFICATIONS:		NEXT ASSY:				

TITLE: RECEP-24-29 POS SOCKET CONT, REDUCED DIA. SEAL, AHDP  
DWG NO.: AHDP04-24-29SR-WTA  
REV: A4  
SH: 1  
OF: 1