

AFBR-5921ALZ

Small Form Factor, Pin Through Hole (PTH), Low Voltage (3.3 V)
2x5 RoHS-Compliant Optical Transceiver for Fibre Channel
2.125/1.0625 GbD 850 nm



Data Sheet



Description

The AFBR-5921ALZ from Avago Technologies is a high performance, cost-effective optical transceiver for serial optical data communications applications operating at 2.125 Gb/s and 1.0625 Gb/s. This module is designed for multimode fiber and operates at a nominal wavelength of 850 nm. The transceiver incorporates 3.3 V DC compatible technology including an 850 nm VCSEL transmitter. The AFBR-5921ALZ offers maximum flexibility to Fibre Channel designers, manufacturers, and system integrators to implement a range of solutions for multimode Fibre Channel applications. This product is fully compliant with all equipment meeting the Fibre Channel FC-PI 200-M5-SN-I and 200-M6-SN-I 2.125 GbD specifications, and is compliant with the Fibre Channel FC-PI 100-M5-SN-I, FC-PI 100-M6-SN-I, FC-PH2 100-M5-SN-I and FC-PH2 100-M6-SN-I 1.0625 GbD specifications. The AFBR-5921ALZ is also compatible with the SFF Multi Source Agreement (MSA).

Applications

- Mass storage system I/O
- Computer system I/O
- High speed peripheral interface
- High speed switching systems
- Host adapter I/O
- RAID cabinets

Features

- Fully RoHS Compliant
- Datarate specification: 2.125 GbD operation for FC-PI 200-M5-SN-I and FC-PI 200-M6-SN-I
1.0625 GbD operation for FC-PI 100-M5-SN-I and FC-PI 100-M6-SN-I
- Link lengths at 2.125 GbD:
0.5 to 300 m – 50/125 μ m MMF
0.5 to 150 m – 62.5/125 μ m MMF
- Link lengths at 1.0625 GbD:
0.5 to 500 m – 50/125 μ m MMF
0.5 to 300 m – 62.5/125 μ m MMF
- Compatible to 2.5G InfiniBand standard
- 850 nm Vertical Cavity Surface Emitting Laser (VCSEL)
- Laser AEL Class I (eye safe) per:
US 21 CFR (J)
EN 60825-1 (+All)
- High Reliability <100 FIT @ 50°C
- Wide temperature and supply voltage operation
- Industry standard 2x5 SFF package
- Wave solder and aqueous wash process compatible

Related Products

- AFBR-59M5LZ: 850 nm RoHS compliant 2x6 for 2.125/1.0625 GbD for Fibre Channel and 1.25 Gigabit Ethernet

AFBR-5921ALZ BLOCK DIAGRAM

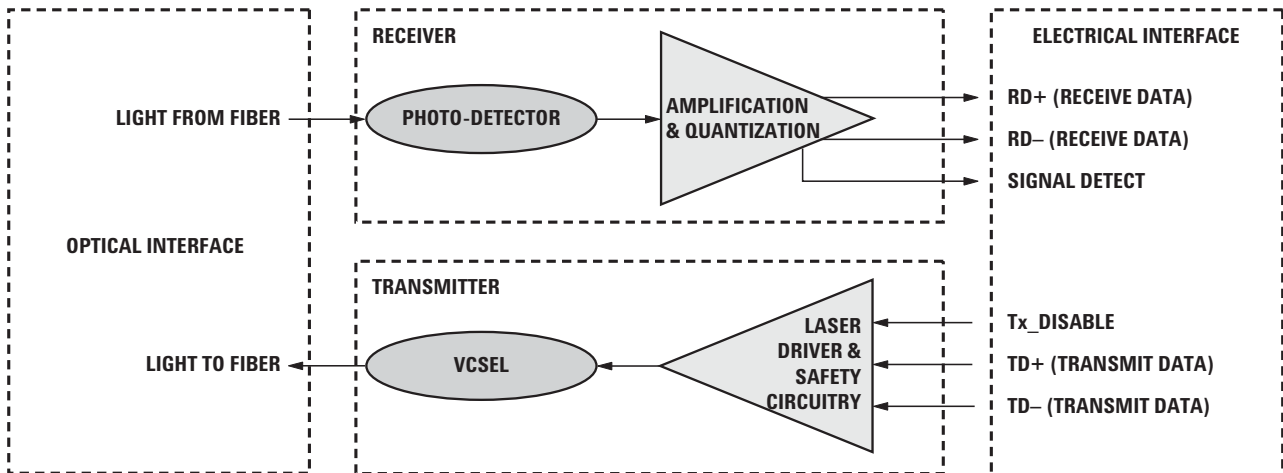

Figure 1. Transceiver functional diagram.

See Table 5 for Process Compatibility Specifications.

Module Package

Avago Technologies offers the Pin Through Hole package utilizing an integral LC-Duplex optical interface connector. The transceiver uses a reliable 850 nm VCSEL source and requires a 3.3 V DC power supply for optimal system design.

Module Diagrams

Figure 1 illustrates the major functional components of the AFBR-5921ALZ. The connection diagram for both modules are shown in Figure 2. Figure 6 depicts the external configuration and dimensions of the module.

Installation

The AFBR-5921ALZ can be installed in any MSA-compliant Pin Through Hole port. The module Pin Description is shown in Figure 2.

Solder and Wash Process Capability

These transceivers are delivered with protective process plugs inserted into the LC connector receptacle. This process plug protects the optical subassemblies during wave solder and aqueous wash processing and acts as a dust cover during shipping. These transceivers are compatible with industry standard wave or hand solder processes.

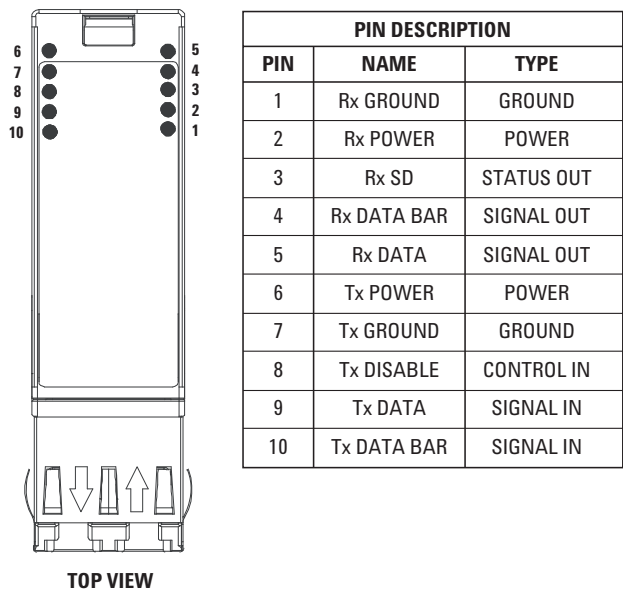

Figure 2. Module pin assignments and pin configuration.

Recommended Solder Fluxes

Solder fluxes used with the AFBR-5921ALZ should be water-soluble, organic fluxes. Recommended solder fluxes include Lonco 3355-11 from London Chemical West, Inc. of Burbank, CA, and 100 Flux from Alpha-Metals of Jersey City, NJ.

Recommended Cleaning/Degreasing Chemicals

Alcohols: methyl, isopropyl, isobutyl.

Aliphatics: hexane, heptane.

Other: naphtha.

Do not use partially halogenated hydrocarbons such as 1,1,1 trichloroethane or ketones such as MEK, acetone, chloroform, ethyl acetate, methylene dichloride, phenol, methylene chloride, or N-methylpyrrolidone. Also, Avago Technologies does not recommend the use of cleaners that use halogenated hydrocarbons because of their potential environmental harm.

Transmitter Section

The transmitter section includes an 850 nm VCSEL (Vertical Cavity Surface Emitting Laser) light source and a transmitter driver circuit. The driver circuit maintains a constant optical power level provided that the data pattern is valid 8B/10B code. Connection to the transmitter is provided via an LC optical connector.

TX Disable

The AFBR-5921ALZ accepts a transmit disable control signal input which shuts down the transmitter. A high signal implements this function while a low signal allows normal laser operation. In the event of a fault (e.g., eye safety circuit activated), cycling this control signal resets the module. The TX Disable control should be actuated upon initialization of the module. See Figure 5 for product timing diagrams.

Eye Safety Circuit

For an optical transmitter device to be eye-safe in the event of a single fault failure, the transmitter will either maintain normal, eye-safe operation or be disabled. In the event of an eye safety fault, the VCSEL will be disabled.

Receiver Section

Connection to the receiver is provided via an LC optical connector. The receiver circuit includes a Signal Detect (SD) circuit which provides an open collector logic low output in the absence of a usable input optical signal level.

Signal Detect

The Signal Detect (SD) output indicates if the optical input signal to the receiver does not meet the minimum detectable level for Fibre Channel compliant signals. When SD is low it indicates loss of signal. When SD is high it indicates normal operation. The Signal Detect thresholds are set to indicate a definite optical fault has occurred (e.g., disconnected or broken fiber connection to receiver, failed transmitter).

Functional Data I/O

Avago Technologies' AFBR-5921ALZ fiber-optic transceiver is designed to accept industry standard differential signals. In order to reduce the number of passive components required on the customer's board, Avago Technologies has included the functionality of the transmitter bias resistors and coupling capacitors within the fiber optic module. The transceiver is compatible with an "AC-coupled" configuration and is internally terminated. Figure 1 depicts the functional diagram of the AFBR-5921ALZ.

Caution should be taken to account for the proper interconnection between the supporting Physical Layer integrated circuits and the AFBR-5921ALZ. Figure 3 illustrates the recommended interface circuit.

Reference Designs

Figure 3 depicts a typical application configuration, while Figure 4 depicts the multisourced power supply filter circuit design.

Regulatory Compliance

See Table 1 for transceiver Regulatory Compliance performance. The overall equipment design will determine the certification level. The transceiver performance is offered as a figure of merit to assist the designer.

Electrostatic Discharge (ESD)

There are two conditions in which immunity to ESD damage is important. Table 1 documents our immunity to both of these conditions. The first condition is during handling of the transceiver prior to attachment to the PCB. To protect the transceiver, it is important to use normal ESD handling precautions. These precautions include using grounded wrist straps, work benches, and floor mats in ESD controlled areas. The ESD sensitivity of the AFBR-5921ALZ is compatible with typical industry production environments. The second condition is static discharges to the exterior of the host equipment chassis after installation. To the extent that the duplex LC optical interface is exposed to the outside of the host equipment chassis, it may be subject to system-level ESD requirements. The ESD performance of the AFBR-5921ALZ exceeds typical industry standards.

Immunity

Equipment hosting the AFBR-5921ALZ modules will be subjected to radio-frequency electromagnetic fields in some environments. The transceivers have good immunity to such fields due to their shielded design.

Electromagnetic Interference (EMI)

Most equipment designs utilizing these high-speed transceivers from Avago Technologies will be required to meet the requirements of FCC in the United States, CENELEC EN55022 (CISPR 22) in Europe and VCCI in Japan. The metal housing and shielded design of the AFBR-5921ALZ minimize the EMI challenge facing the host equipment designer. These transceivers provide superior EMI performance. This greatly assists the designer in the management of the overall system EMI performance.

Eye Safety

These 850 nm VCSEL-based transceivers provide Class 1 eye safety by design. Avago Technologies has tested the transceiver design for compliance with the requirements listed in Table 1: Regulatory Compliance, under normal operating conditions and under a single fault condition.

Reliability

These transceivers have an estimated failure rate of <100 FITS @ 50°C.

Flammability

The AFBR-5921ALZ VCSEL transceiver housing is made of metal and high strength, heat resistant, chemically resistant, and UL 94V-0 flame retardant plastic.

Caution

There are no user serviceable parts nor is any maintenance required for the AFBR-5921ALZ. All adjustments are made at the factory before shipment to our customers. Tampering with or modifying the performance of the AFBR-5921ALZ will result in voided product warranty. It may also result in improper operation of the AFBR-5921ALZ circuitry, and possible overstress of the laser source. Device degradation or product failure may result. Connection of the AFBR-5921ALZ to a non-approved optical source, operating above the recommended absolute maximum conditions or operating the AFBR-5921ALZ in a manner inconsistent with its design and function may result in hazardous radiation exposure and may be considered an act of modifying or manufacturing a laser product. The person(s) performing such an act is required by law to re-certify and re-identify the laser product under the provisions of U.S. 21 CFR (Subchapter J) and the TUV.

Table 1. Regulatory Compliance

Feather	Test Method	Performance
Electrostatic Discharge (ESD) to the Electrical Pins	MIL-STD-889C Method 3015.4	Class 2 (> 2000V)
Electrostatic Discharge (ESD) to the Duplex LC Receptacle	Variation of IEC 61000-4-2	Typically withstand at least 25kV without damage when the duplex LC connector receptacle is contacted by a Human Body Model probe.
Electromagnetic Interference (EMI)	FCC Class B CENELEC EN55022 Class B (CISPR 22A) VCCI Class	System margins are dependent on customer board and chassis design.
Immunity	Variation of IEC 61000-4-3	Typically shows a negligible effect from a 10 V/m field swept from 80 to 1000 MHz applied to the transceiver without a chassis enclosure.
Eye Safety	US FDA CDRH AEL Class 1 EN(IEC)60825-1,2 EN60950 Class 1	CDRH file #TBD TUV file #TBD
Component Recognition	Underwriters Laboratories and UL Canadian Standards Association Joint Component Recognition for Information Technology Equipment including Electrical Business Equipment.	UL file #TBD
RoHS Compliance		Less than 1000 ppm of cadmium, lead, mercury, hexavalent chromium, polybrominated biphenyls and polybrominated biphenyl

Ordering Information

Please contact your local field sales engineer or one of Avago Technologies franchised distributors for ordering information. For technical information regarding this product, including the MSA, please visit Avago Technologies Semiconductors Products Website at www.avagotech.com. Use the quick search feature to search for this part number. You may also contact Avago Technologies Customer Response Center at 1-800-235-0312.

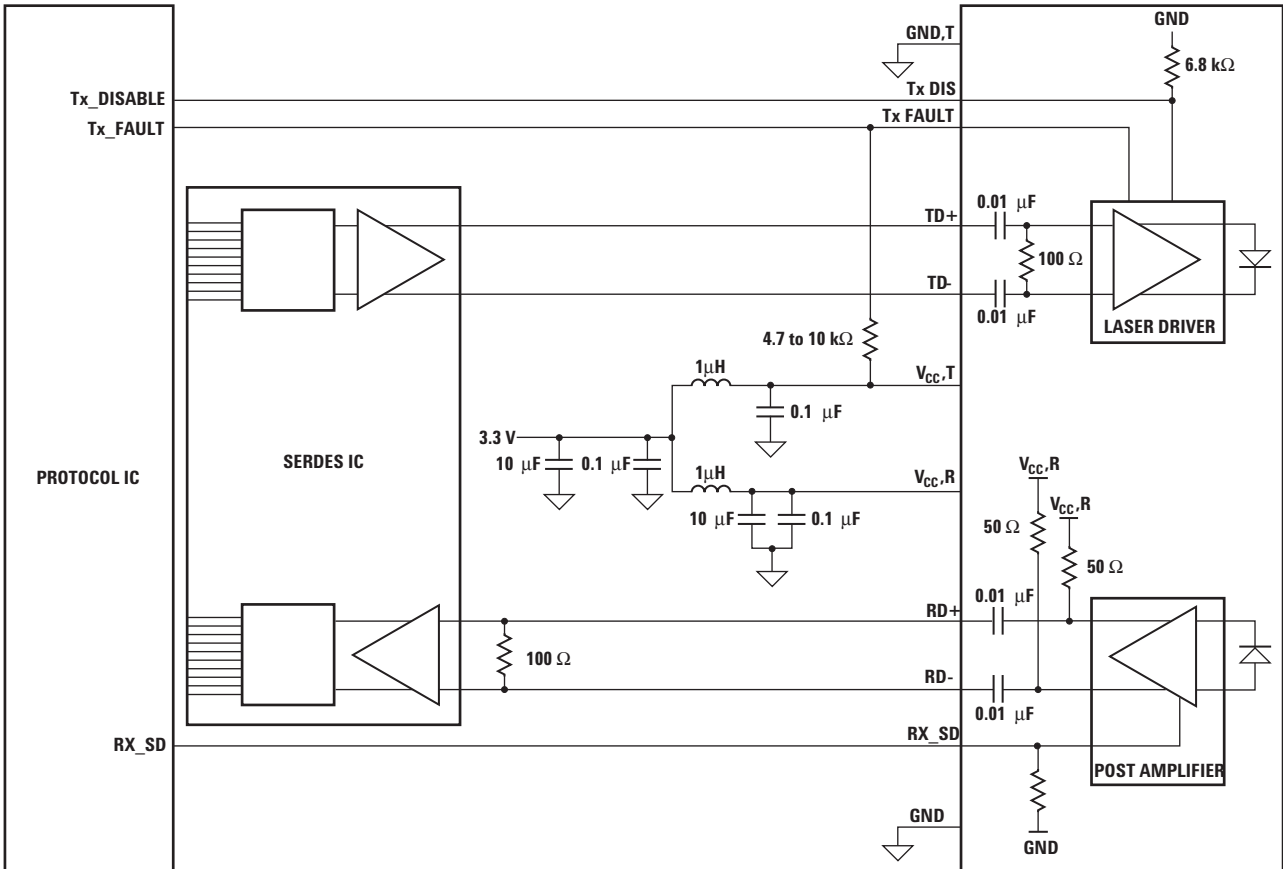
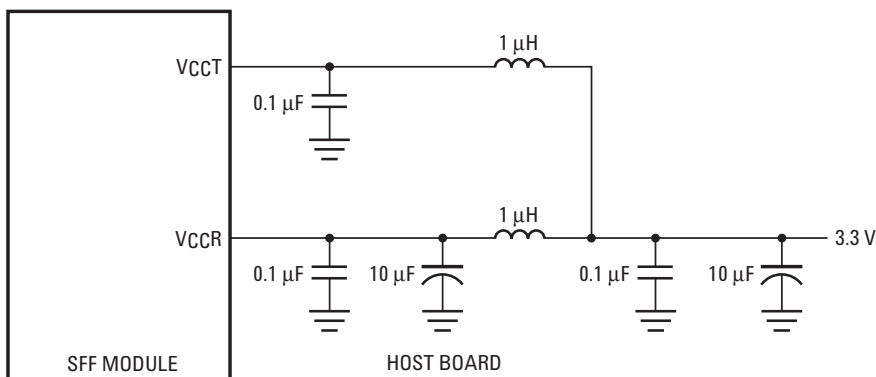

Figure 3. Typical application configuration.



NOTE: INDUCTORS MUST HAVE LESS THAN 1 Ω SERIES RESISTANCE PER MSA.

Figure 4. MSA recommended power supply filter.

Table 2. Pin Description

Pin	Name	Function/Description	MSA Notes
1	V _{EE} R	Receiver Ground	1
2	V _{CC} R	Receiver Power: 3.3V ±10%	5
3	SD		3
4	RD-	Inverse Received Data Out	4
5	RD+	Received Data Out	4
6	V _{CC} T	Transmitter Power: 3.3V ±10%	5
7	V _{EE} T	Transmitter Ground	1
8	TX Disable	Transmitter Disable: Module disables on High	2
9	TD+	Transmitter Data In	
10	TD-	Inverse Transmitter Data In	

Notes:

- Transmitter and Receiver Ground are common in the internal module PCB. They are electrically connected to signal ground within the module, and to the housing shield (see Note 5 in Figure 7c). This housing shield is electrically isolated from the nose shield which is connected to chassis ground (see Note 4 in Figure 7c).
- TX disable input is used to shut down the laser output per the state table below. It is pulled down internally within the module with a 9.0 kΩ resistor.

Low (0 – 0.8 V):	Transmitter on
Between (0.8 V and 2.0 V):	Undefined
High (2.0 – 3.63 V):	Transmitter Disabled
Open:	Transmitter Disabled
- SD (Signal Detect) is a normally high LVTTTL output. When high it indicates that the received optical power is adequate for normal operation. When Low, it indicates that the received optical power is below the worst case receiver sensitivity, a fault has occurred, and the link is no longer valid.
- RD-/+ : These are the differential receiver outputs. They are AC coupled 100 Ω differential lines which should be terminated with 100 Ω differential at the user SerDes. The AC coupling is done inside the module and is thus not required on the host board. The voltage swing on these lines will be between 400 and 2000 mV differential (200 – 1000 mV single ended) when properly terminated. These levels are compatible with CML and LVPECL voltage swings.
- V_{CC}R and V_{CC}T are the receiver and transmitter power supplies. They are defined as 2.97 – 3.63 V at the PTH connector pin. The maximum supply current is 200 mA.

Table 3. Absolute Maximum Ratings

Parameter	Symbol	Minimum	Typical	Maximum	Unit	Notes
Storage Temperature	T _s	-40		+100	°C	1
Case Temperature	T _C	-10		+85	°C	1,2
Relative Humidity	RH	5		95	%	1
Supply Voltage	V _{CC} T,R	-0.5		4	V	1,2
Data/Control Input Voltage	V _I	-0.5		V _{CC} + 0.3	V	1
Sense Output Current Signal Detect (SD)	I _D			5.0	mA	1

Notes:

- Absolute Maximum Ratings are those values beyond which damage to the device may occur if these limits are exceeded for other than a short period of time. See Reliability Data Sheets for specific reliability performance.
- Between Absolute Maximum Ratings and the Recommended Operating Conditions, functional performance is not intended, device reliability is not implied, and damage to the device may occur over an extended period of time.

Table 4. Recommended Operating Conditions

Parameter	Symbol	Minimum	Typical	Maximum	Unit	Notes
Case Temperature	T _C	-10	+25	+85	°C	1
Module Supply Voltage	V _{CC} T,R	2.97	3.3	3.63	V	1
Data Rate Fibre Channel			1.0625 2.125		Gb/s	1

Note:

1. Recommended operating conditions are those values outside of which functional performance is not intended, device reliability is not implied, and damage to the device may occur over an extended period of time. See Reliability Data Sheet for specific reliability performance.

Table 5. Process Compatibility

Parameter	Symbol	Minimum	Typical	Maximum	Unit	Notes
Hand Lead Solder Temperature	T _{solder}			+260	°C	
Time	t _{time}			10	see	
Wave Solder and Aqueous Wash Temperature	T _{solder}			+260	°C	1
Time	t _{time}			10	see	1

Note:

1. Aqueous wash pressure < 110 psi.

Table 6. Transceiver Electrical Characteristics

(T_C = -10°C to +85°C, V_{CC} = 3.3 V ± 10%)

Parameter	Symbol	Minimum	Typical	Maximum	Unit	Notes
AC Electrical Characteristics						
Power Supply Noise Rejection(Peak-to-Peak)	PSNR		100		mV	1
DC Electrical Characteristics						
Module Supply Current	I _{CC}			200	mA	
Power Dissipation	P _{DISS}			726	mW	
Sense Outputs:Signal Detect [SD]	V _{OH}	24		V _{CC} R+0.3	V	2
	V _{OL}			0.4	V	
Control Inputs: Transmitter Disable [TX_DISABLE]	V _{IH}	2.0		V _{CC} + 0.3	V	3
	V _{IL}	0.0		0.8	V	

Notes:

1. MSA filter is required on host board 10 Hz to 2 MHz.
2. LVTTTL, 1.2 kW internal pull-up resistor to V_{CC}R.
3. 9.0 kW internal pull-down resistor to V_{EE}.
4. Please refer to the AFBR-5921ALZ Characterization Report for typical values.

Table 7. Transmitter and Receiver Electrical Characteristics $(T_C = -10^{\circ}\text{C to } +85^{\circ}\text{C}, V_{CC} = 3.3\text{ V} \pm 10\%)$

Parameter	Symbol	Minimum	Typical	Maximum	Unit	Notes
Data Input: Transmitter Differential Input Voltage (TD +/-)	V_I	400		2400	mV	1
Data Output: Receiver Differential Output Voltage (RD +/-)	V_O	500	625	2000	mV	2
Receive Data Rise and Fall Times (Receiver)	Trise/fall			200	ps	3
Contributed Deterministic Jitter (Receiver) 2.125 Gb/s	DJ		0.1	UI		4,6
			47	ps		
Contributed Deterministic Jitter (Receiver) 1.0625 Gb/s	DJ		0.12	UI		4,6
			113	ps		
Contributed Random Jitter (Receiver) 2.125 Gb/s	RJ		0.162	UI		5,6
			76	ps		
Contributed Random Jitter (Receiver) 1.0625 Gb/s	RJ		0.09	UI		5,6
			92	ps		

Notes:

- Internally AC coupled and terminated (100 Ohm differential). These levels are compatible with CML and LVPECL voltage swings.
- Internally AC coupled with internal 50 ohm pullups to V_{CC} (single-ended) and a required external 100 ohm differential load termination.
- 20%-80% Rise and Fall times measured with a 500 MHz signal utilizing a 1010 data pattern.
- Contributed DJ is measured on an oscilloscope in average mode with 50% threshold and K28.5 pattern.
- Contributed RJ is calculated for 1E-12 BER by multiplying the RMS jitter (measured on a single rise or fall edge) from the oscilloscope by 14. Per the FC-PI standard (Table 13 - MM jitter output, note 1), the actual contributed RJ is allowed to increase above its limit if the actual contributed DJ decreases below its limits, as long as the component output DJ and TJ remain within their specified FC-PI maximum limits with the worst case specified component jitter input.
- In a network link, each component's output jitter equals each component's input jitter combined with each component's contributed jitter. Contributed DJ adds in a linear fashion and contributed RJ adds in a RMS fashion. In the Fibre Channel specification, there is a table specifying the input and output DJ and TJ for the receiver at each data rate. In that table, RJ is found from $TJ - DJ$, where the RX input jitter is noted as Gamma R, and the RX output jitter is noted as Delta R. The AFBR-5921ALZ contributed jitter is such that, if the maximum specified input jitter is present, and is combined with our maximum contributed jitter, then we meet the specified maximum output jitter limits listed in the FC-PI MM jitter specification table.
- Please refer to the AFBR-5921ALZ Characterization Report for typical values.

Table 8. Transmitter Optical Characteristics $(T_C = -10^\circ\text{C to } +85^\circ\text{C}, V_{CC} = 3.3\text{ V} \pm 10\%)$

Parameter	Symbol	Minimum	Typical	Maximum	Unit	Notes
Output Optical Power (Average)	P _{OUT}	-10		0	dBm	50/125 μm NA = 0.2 Note 1
	P _{OUT}	-10		0	dBm	62.5/125 μm NA = 0.275 Note 1
Optical Extinction Ratio	FR		9		dB	
Optical Modulation Amplitude (Peak-to-Peak) 2.125 Gb/s	OMA	196			μW	FC-PI Std Note 2
Optical Modulation Amplitude (Peak-to-Peak) 1.0625 Gb/s	OMA	156			μW	FC-PI Std Note 3
Center Wavelength	λ_C	830		860	nm	FC-PI Std
Spectral Width – rms	σ			0.85	nm	FC-PI Std
Optical Rise /Fall Time	T _{rise/fall}			150	ps	20%–80%, FC-PI Std
RIN ₁₂ (OMA),maximum	RIN			-117	dB/Hz	FC-PI Std
Contributed Deterministic Jitter (Transmitter) 2.125 Gb/s	DJ			0.12	UI	4,5
				56	ps	
Contributed Deterministic Jitter (Transmitter) 1.0625 Gb/s	DJ			0.09	UI	4,6
				85	ps	
Contributed Random Jitter (Transmitter) 2.125 Gb/s	RJ			0.134	UI	5,6
				63	ps	
Contributed Random Jitter (Transmitter) 1.0625 Gb/s	RJ			0.177	UI	5,6
				167	ps	
P _{OUT} TX_DISABLEAsserted	P _{OFF}			-35	dBm	

Notes:

1. Max P_{out} is the lesser of 0 dBm or Maximum allowable per Eye Safety Standard.
2. An OMA of 196 is approximately equal to an average power of -9 dBm assuming an Extinction Ratio of 9 dB.
3. An OMA of 156 is approximately equal to an average power of -10 dBm assuming an Extinction Ratio of 9 dB.
4. Contributed RJ is calculated for 1E-12 BER by multiplying the RMS jitter (measured on a single rise or fall edge) from the oscilloscope by 14. Per the FC-PI standard (Table 13 - MM jitter output, note 1), the actual contributed RJ is allowed to increase above its limit if the actual contributed DJ decreases below its limits, as long as the component output DJ and TJ remain within their specified FC-PI maximum limits with the worst case specified component jitter input.
5. In a network link, each component's output jitter equals each component's input jitter combined with each components contributed jitter. Contributed DJ adds in a linear fashion and contributed RJ adds in a RMS fashion. In the Fibre Channel specification, there is a table specifying the input and output DJ and TJ for the transmitter at each data rate. In that table, RJ is found from TJ-DJ, where the TX input jitter is noted as Delta T, and the TX output jitter is noted as Gamma T. The AFBR-5921ALZ contributed jitter is such that, if the maximum specified input jitter is present, and is combined with our maximum contributed jitter, then we meet the specified maximum output jitter limits listed in the FC-PI MM jitter specification table.
6. Please refer to the AFBR-5921ALZ Characterization Report for typical values.

Table 9. Receiver Optical Characteristics(T_C = -10°C to +85°C, V_{CC} = 3.3 V ± 10%)

Parameter	Symbol	Minimum	Typical	Maximum	Unit	Notes
Optical Power	PIN			0	dBm	FC-PI Std
Min Optical Modulation Amplitude (Peak-to-Peak) 2.125 Gb/s	OMA	49			μW	FC-PI Std Note 1
Min Optical Modulation Amplitude (Peak-to-Peak) 1.0625 Gb/s	OMA	31			μW	FC-PI Std Note 2
Stressed Receiver Sensitivity 62.5 μm fiber 2.125 Gb/s	OMA	109			μW	Note 3
	OMA	67			μW	Note 5
50 μm fiber 2.125 Gb/s	OMA	96			μW	Note 4
	OMA	55			μW	Note 5
Return Loss		12			dB	FC-PI Std
Signal Detect – De-Assert	P _D	-31		-17.5	dBm	
Signal Detect – Assert	P _A			-17.0	dBm	
Signal Detect – Hysteresis	P _A -P _D	0.5	3.1	5	dB	

Notes:

1. An OMA of 49 uW is approximately equal to an average power of -15dBm, and the OMA typical of 16 uW is approximately equal to an average power of -20 dBm, assuming an Extinction Ratio of 9dB. Sensitivity measurements are made at eye center with BER = 1E-10.
2. An OMA of 31 is approximately equal to an average power of -17 dBm assuming an Extinction Ratio of 9 dB.
3. 2.125 Gb/s Stressed receiver vertical eye closure penalty (ISI) min. is 1.26 dB for 50 μm fiber and 2.03 dB for 62.5 μm fiber. Stressed receiver DCD component min. (at TX) is 40 ps.
4. 1.0625 Gb/s Stressed receiver vertical eye closure penalty (ISI) min. is 0.96 dB for 50 μm fiber and 2.18 dB for 62.5 μm fiber. Stressed receiver DCD component min. (at TX) is 80 ps.
5. These average power values are specified with an Extinction Ratio of 9 dB. The Signal Detect circuitry responds to OMA (peak-to-peak) power, not to average power.
6. Please refer to the AFBR-5921ALZ Characterization Report for typical values.

Table 10. Transceiver Timing Characteristics(T_C = -10°C to +85°C, V_{CC} = 3.3 V ± 10%)

Parameter	Symbol	Minimum	Maximum	Unit	Notes
TX Disable Assert Time	t _{off}		10	μs	1
TX Disable Negate Time	t _{on}		1	ms	2
Time to Initialize	t _{init}		30	ms	3
TX Disable to Reset	t _{reset}	10		μs	4
SD Assert Time	t _{loss_on}		100	μs	5
SD De-assert Time	t _{loss_off}		100	μs	6

Notes:

1. Time from rising edge of TX Disable to when the optical output falls below 10% of nominal.
2. Time from falling edge of TX Disable to when the modulated optical output rises above 90% of nominal.
3. From power on or negation of TX Fault using TX Disable.
4. Time TX Disable must be held high to reset TX Fault.
5. Time from optical signal loss to SD Assert. See transceiver timing diagrams.
6. Time from optical signal recovery to SD De-assert. See transceiver timing diagrams.

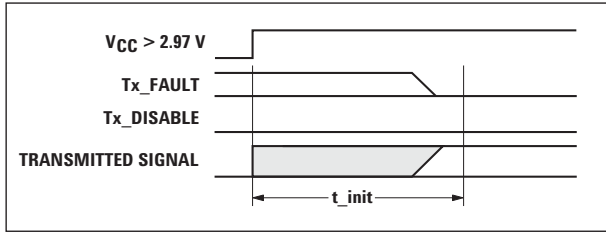

t-init: TX DISABLE DE-ASSERTED

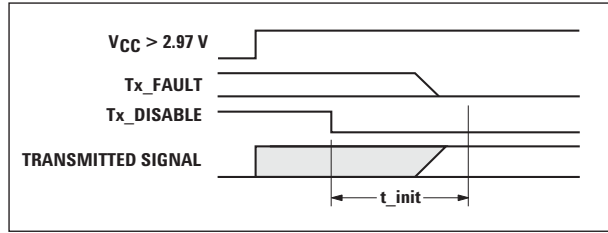

t-init: TX DISABLE ASSERTED

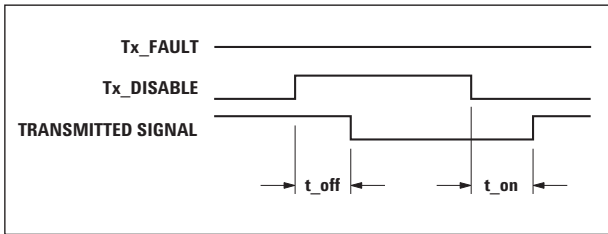

t-off & t-on: TX DISABLE ASSERTED THEN NEGATED

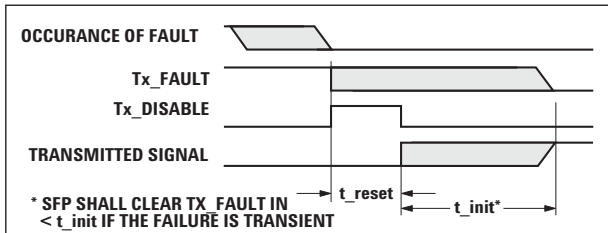

t-reset: TX DISABLE ASSERTED THEN NEGATED, TX SIGNAL RECOVERED

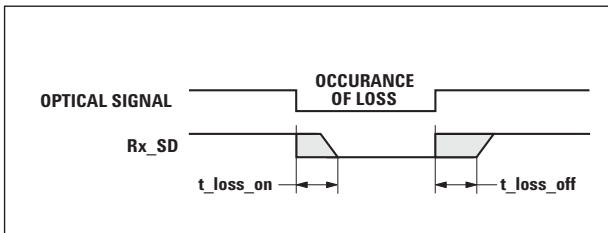

t-loss-on & t-loss-off

Figure 5. Transceiver timing diagrams.

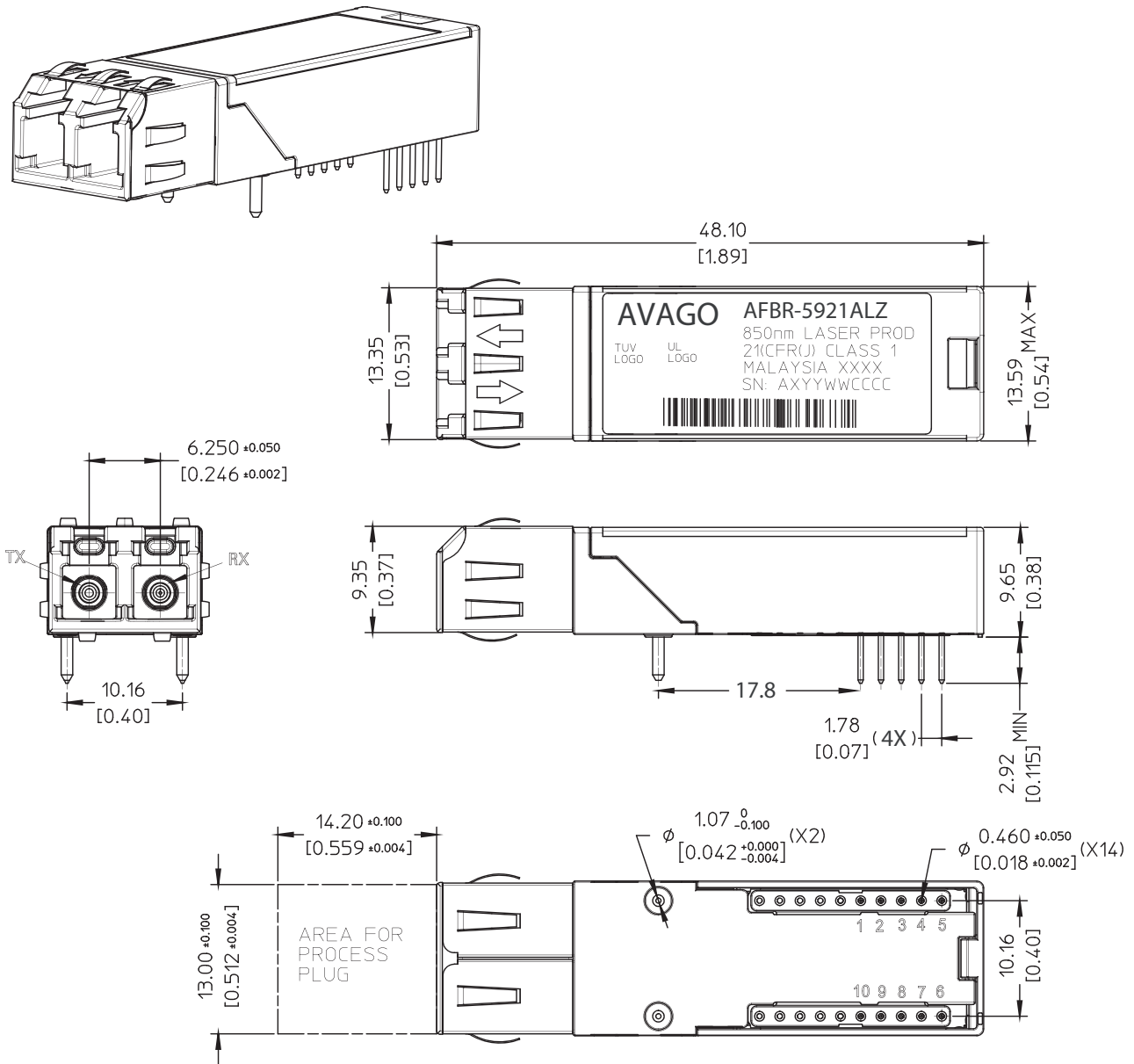
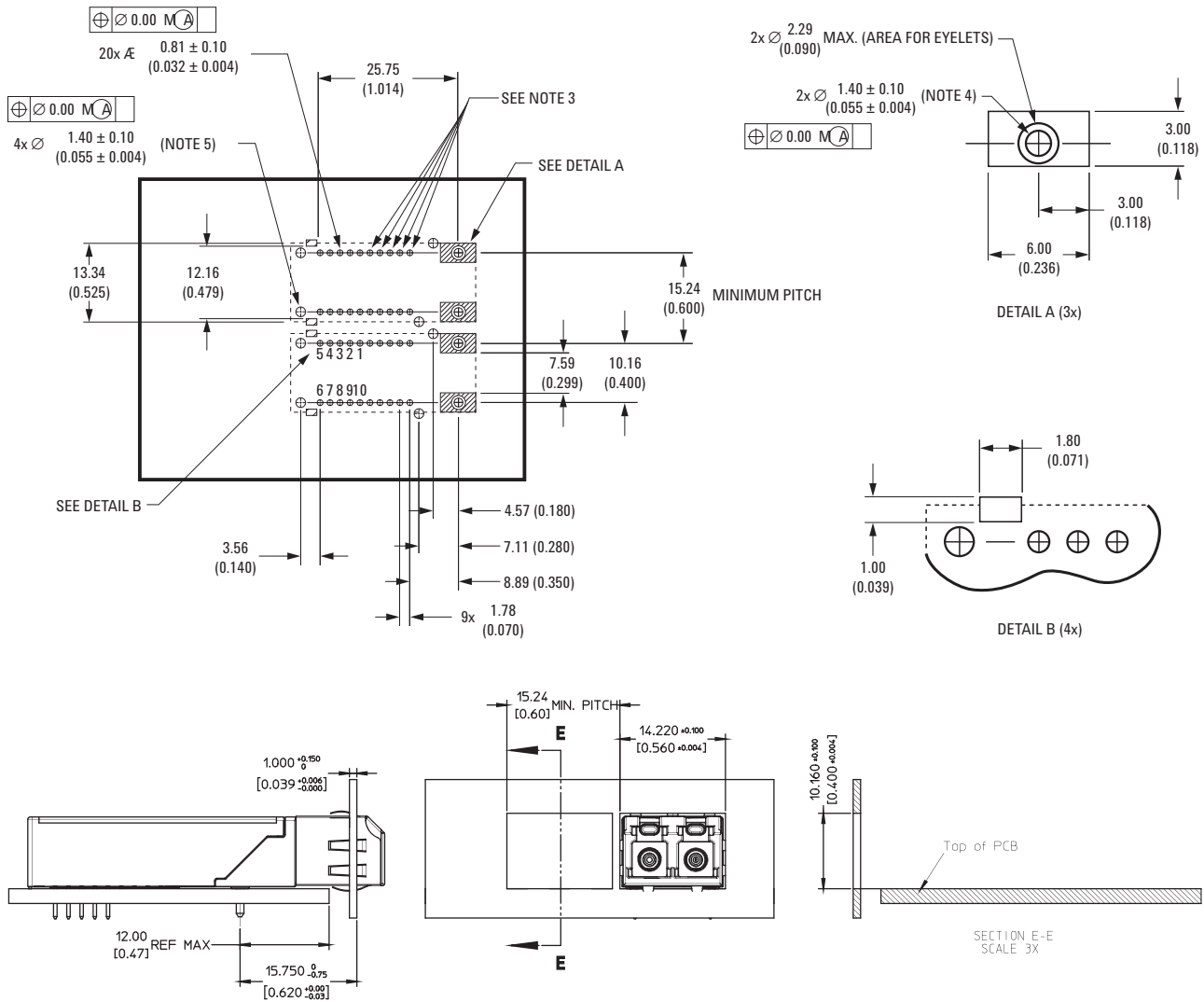

Figure 6a. Module drawing.



Notes:

1. This page describes the recommended circuit board layout and front panel openings for SFF transceivers.
2. The hatched areas are keep-out areas reserved for housing standoffs. No metal traces allowed in keep-out areas.
3. This drawing shows extra pin holes for 2x10 pin transceivers. These extra holes are not required for HFBR-5921AL.
4. Holes for mounting studs must be tied to chassis ground.
5. Holes for housing leads must be tied to signal ground.
6. Dimensions are in millimeters (inches).

Figure 6b. Recommended SFF host board and front panel layout.

For product information and a complete list of distributors, please go to our web site: www.avagotech.com

Avago, Avago Technologies, and the A logo are trademarks of Avago Technologies in the United States and other countries. Data subject to change. Copyright © 2005-2010 Avago Technologies. All rights reserved. AV02-2199EN - December 16, 2010

