



16-Bit 250kHz Sampling CMOS ANALOG-to-DIGITAL CONVERTER

FEATURES

- 250kHz SAMPLING RATE
- COMPLETE WITH S/H, REF, CLOCK, ETC.
- 96dB min SFDR WITH 100kHz INPUT
- 82dB min SINAD WITH 100kHz INPUT
- $\pm 2.5V$ INPUT RANGE
- 28-LEAD SOIC

APPLICATIONS

- WIRELESS BASE STATIONS
- SPECTRUM ANALYSIS
- IMAGING SYSTEMS
- DATA ACQUISITION

DESCRIPTION

The ADS7815 is a complete 16-bit sampling analog-to-digital (A/D) converter featuring excellent AC performance and a 250kHz throughput rate. The design includes a 16-bit capacitor-based SAR A/D converter with an inherent sample and hold (S/H), a precision reference, and an internal clock. Spurious-free dynamic range with a 100kHz full-scale sinewave input is typically greater than 100dB. The $\pm 2.5V$ input range allows development of precision systems using only $\pm 5V$ supplies. The converter is available in a 28-lead SOIC package specified for operation over the industrial $-25^{\circ}C$ to $+85^{\circ}C$ temperature range.

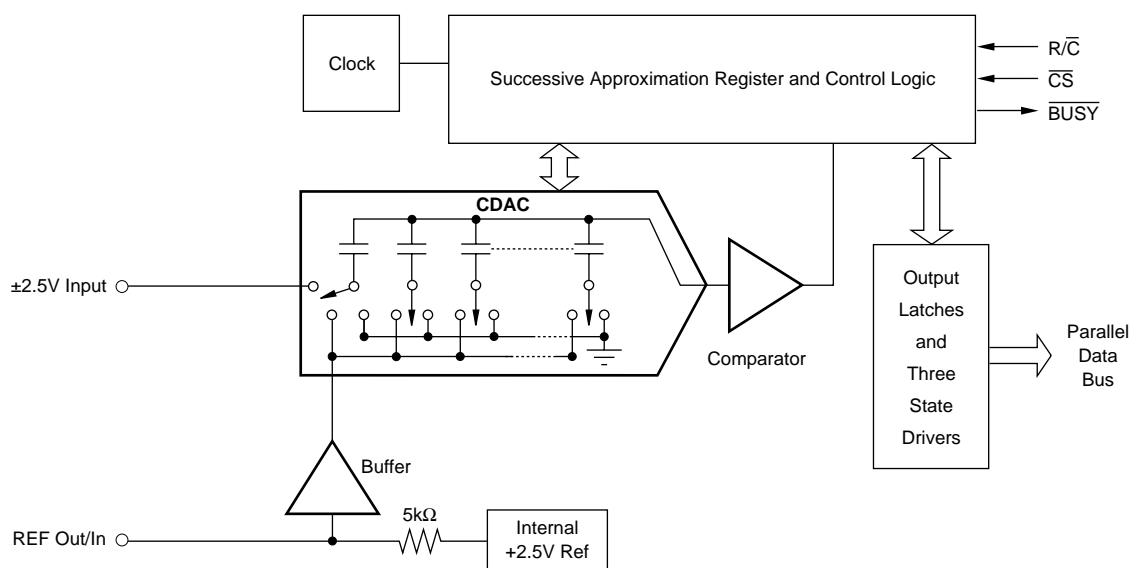

Please be aware that an important notice concerning availability, standard warranty, and use in critical applications of Texas Instruments semiconductor products and disclaimers thereto appears at the end of this data sheet.

All trademarks are the property of their respective owners.

ABSOLUTE MAXIMUM RATINGS

Analog Inputs: V_{IN}	$\pm V_S$
REF	GND $-0.3V$ to $+V_S +0.3V$
CAP	Indefinite Short to GND Momentary Short to $+V_S$
$+V_S$	$7V$
$-V_S$	$-7V$
Digital Inputs	GND $-0.3V$ to $+V_S +0.3V$
Maximum Junction Temperature	$+165^{\circ}C$
Internal Power Dissipation	$825mW$
Lead Temperature (soldering, 10s)	$+300^{\circ}C$

PACKAGE/ORDERING INFORMATION⁽¹⁾

PRODUCT	PACKAGE	PACKAGE DESIGNATOR	TEMPERATURE RANGE
ADS7815U	28-Pin SOIC	DW	$-25^{\circ}C$ to $+85^{\circ}C$

NOTE: (1) For the most current package and ordering information, see the Package Option Addendum at the end of this data sheet, or see the TI website at www.ti.com.



ELECTROSTATIC DISCHARGE SENSITIVITY

This integrated circuit can be damaged by ESD. Texas Instruments recommends that all integrated circuits be handled with appropriate precautions. Failure to observe proper handling and installation procedures can cause damage.

ESD damage can range from subtle performance degradation to complete device failure. Precision integrated circuits may be more susceptible to damage because very small parametric changes could cause the device not to meet its published specifications.

ELECTRICAL CHARACTERISTICS

At $T_A = -25^{\circ}\text{C}$ to $+85^{\circ}\text{C}$, $f_S = 250\text{kHz}$, $+V_S = +5\text{V}$, and $-V_S = -5\text{V}$, using internal reference, unless otherwise specified.

PARAMETER	CONDITIONS	ADS7815U			UNITS
		MIN	TYP	MAX	
RESOLUTION				16	Bits
ANALOG INPUT					
Voltage Range			$\pm 2.5\text{V}$		V
Impedance			100		$\text{M}\Omega$
Capacitance			30		pF
THROUGHPUT SPEED					
Conversion Cycle	Acquire and Convert			4.0	μs
Throughput Rate		250			kHz
DC ACCURACY					
Integral Linearity Error			± 4		LSB ⁽¹⁾
No Missing Codes			15		Bits
Transition Noise ⁽²⁾			0.8		LSB
Full Scale Error ⁽³⁾			± 0.1		%
Full Scale Error Drift			± 7		ppm/ $^{\circ}\text{C}$
Bipolar Zero Error			± 2		mV
Bipolar Zero Error Drift			± 2		ppm/ $^{\circ}\text{C}$
Power Supply Sensitivity	$+V_S \pm 5\%$, $-V_S \pm 5\%$		± 6		LSB
AC ACCURACY					
Spurious-Free Dynamic Range	$f_{IN} = 100\text{kHz}$	96	100		dB ⁽⁴⁾
Total Harmonic Distortion	$f_{IN} = 100\text{kHz}$		-98	-94	dB
Signal-to-(Noise+Distortion)	$f_{IN} = 100\text{kHz}$	82			dB
	-60dB Input		28		dB
Signal-to-Noise	$f_{IN} = 100\text{kHz}$	82			dB
Usable Bandwidth ⁽⁵⁾			1		MHz
Aperture Delay			40		ns
REFERENCE					
Internal Reference Voltage		2.45	2.5	2.55	V
Internal Reference Source Current			1		μA
External Reference Voltage Range		2.3	2.5	2.7	V
External Reference Current Drain	$V_{REF} = +2.5\text{V}$			100	μA
DIGITAL INPUTS					
Logic Levels					
V_{IL}		-0.3		+0.8	V
V_{IH}		+2.8		$+V_S + 0.3\text{V}$	V
I_{IL}				± 10	μA
I_{IH}				± 10	μA
DIGITAL OUTPUTS					
Data Format			Parallel 16 bits		
Data Coding			Binary Two's Complement		
V_{OL}	$I_{SINK} = 1.6\text{mA}$			+0.4	V
V_{OH}	$I_{SOURCE} = 200\mu\text{A}$	+4			V
Leakage Current	High-Z State, $V_{OUT} = 0\text{V}$ to V_{DIG} High-Z State			± 5	μA
Output Capacitance				15	pF
DIGITAL TIMING					
Bus Access Time				83	ns
Bus Relinquish Time				83	ns
POWER SUPPLIES					
$+V_S$		+4.75	+5	+5.25	V
$-V_S$		-5.25	-5	-4.75	V
$+I_S$			+30		mA
$-I_S$			-10		mA
Power Dissipation			200	250	mW
TEMPERATURE RANGE					
Specified Performance		-25		+85	$^{\circ}\text{C}$
Storage		-55		+125	$^{\circ}\text{C}$

NOTES: (1) LSB means Least Significant Bit. For the 16-bit, $\pm 2.5\text{V}$ input ADS7815, one LSB is $76\mu\text{V}$.

(2) Typical rms noise at worst case transitions and temperatures.

(3) Full scale error is the worst case of -Full Scale or +Full Scale untrimmed deviation from ideal first and last code transitions, divided by the transition voltage (not divided by the full-scale range) and includes the effect of offset error.

(4) All specifications in dB are referred to a full-scale $\pm 2.5\text{V}$ input.

(5) Full-Power Bandwidth defined as Full-Scale input frequency at which Signal-to-(Noise+Distortion) degrades to 60dB, or 10 bits of accuracy.

PIN CONFIGURATION

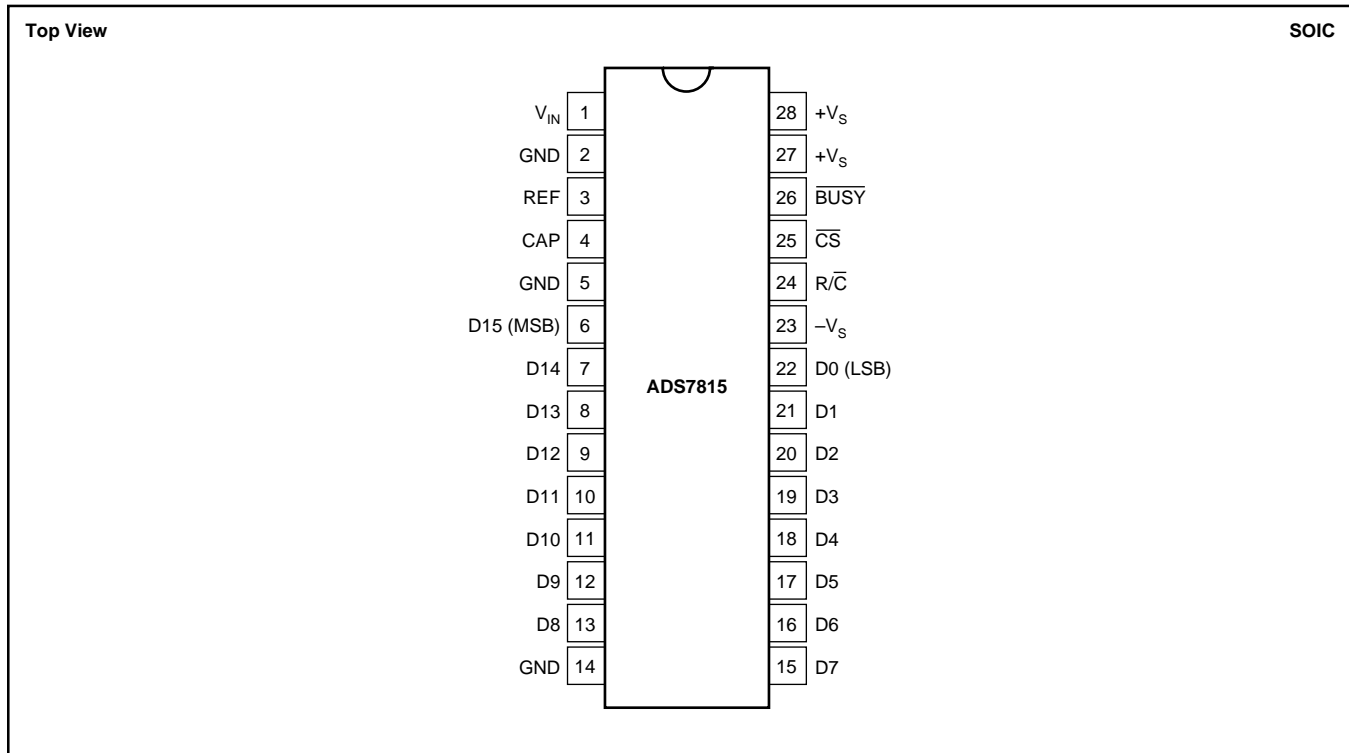

PIN #	NAME	DESCRIPTION
1	V _{IN}	Analog Input. Full-scale input range is ±2.5V.
2	GND	Ground.
3	REF	Reference Input/Output. Outputs internal reference of +2.5V nominal. Can also be driven by external system reference. In both cases, connect to ground with a 0.1μF ceramic capacitor in parallel with 2.2μF tantalum capacitor.
4	CAP	Reference compensation capacitor. Use a parallel combination of a 0.1μF ceramic capacitor and a 2.2μF tantalum capacitor.
5	GND	Ground.
6	D15 (MSB)	Data Bit 15. Most Significant Bit (MSB) of conversion results. Hi-Z state when \overline{CS} is HIGH, when R/\overline{C} is LOW or when a conversion is in progress.
7	D14	Data Bit 14. Hi-Z state when \overline{CS} is HIGH, when R/\overline{C} is LOW or when a conversion is in progress.
8	D13	Data Bit 13. Hi-Z state when \overline{CS} is HIGH, when R/\overline{C} is LOW or when a conversion is in progress.
9	D12	Data Bit 12. Hi-Z state when \overline{CS} is HIGH, when R/\overline{C} is LOW or when a conversion is in progress.
10	D11	Data Bit 11. Hi-Z state when \overline{CS} is HIGH, when R/\overline{C} is LOW or when a conversion is in progress.
11	D10	Data Bit 10. Hi-Z state when \overline{CS} is HIGH, when R/\overline{C} is LOW or when a conversion is in progress.
12	D9	Data Bit 9. Hi-Z state when \overline{CS} is HIGH, when R/\overline{C} is LOW or when a conversion is in progress.
13	D8	Data Bit 8. Hi-Z state when \overline{CS} is HIGH, when R/\overline{C} is LOW or when a conversion is in progress.
14	GND	Ground.
15	D7	Data Bit 7. Hi-Z state when \overline{CS} is HIGH, when R/\overline{C} is LOW or when a conversion is in progress.
16	D6	Data Bit 6. Hi-Z state when \overline{CS} is HIGH, when R/\overline{C} is LOW or when a conversion is in progress.
17	D5	Data Bit 5. Hi-Z state when \overline{CS} is HIGH, when R/\overline{C} is LOW or when a conversion is in progress.
18	D4	Data Bit 4. Hi-Z state when \overline{CS} is HIGH, when R/\overline{C} is LOW or when a conversion is in progress.
19	D3	Data Bit 3. Hi-Z state when \overline{CS} is HIGH, when R/\overline{C} is LOW or when a conversion is in progress.
20	D2	Data Bit 2. Hi-Z state when \overline{CS} is HIGH, when R/\overline{C} is LOW or when a conversion is in progress.
21	D1	Data Bit 1. Hi-Z state when \overline{CS} is HIGH, when R/\overline{C} is LOW or when a conversion is in progress.
22	D0 (LSB)	Data Bit 0. Least Significant Bit (LSB) of conversion results. Hi-Z state when \overline{CS} is HIGH, when R/\overline{C} is LOW or when a conversion is in progress.
23	-V _S	Negative supply input. Nominally -5V. Decouple to analog ground with 0.1μF ceramic and 10μF tantalum capacitors.
24	R/ \overline{C}	Read/convert input. With R/\overline{C} HIGH, \overline{CS} going LOW will enable the output data bits if a conversion is not in progress. With R/\overline{C} LOW, \overline{CS} going LOW will start a conversion if one is not already in progress.
25	\overline{CS}	Chip select. With R/\overline{C} LOW, \overline{CS} going LOW will initiate a conversion if one is not already in progress. With R/\overline{C} HIGH, \overline{CS} going LOW will enable the output data bits if a conversion is not in progress.
26	\overline{BUSY}	Busy output. Falls when a conversion is started, and remains LOW until the conversion is completed. With \overline{CS} LOW and R/\overline{C} HIGH, output data will be valid when \overline{BUSY} rises, so that the rising edge can be used to latch the data. \overline{CS} or R/\overline{C} must be HIGH within 250ns after \overline{BUSY} rises or another conversion will start without time for signal acquisition.
27	+V _S	Positive supply input. Nominally +5V. Connect directly to pin 28.
28	+V _S	Positive supply input. Nominally +5V. Connect directly to pin 27. Decouple to ground with 0.1μF ceramic and 10μF tantalum capacitors.

TABLE I. Pin Assignments.

BASIC OPERATION

Figure 1 shows the recommended circuit for operation of the ADS7815. A falling edge on the convert pulse signal places the sample and hold into the hold mode and initiates a conversion. When the conversion is complete, the pins D15 through D0 become active and the result of the conversion

is placed on these outputs. In the circuit shown in Figure 1, the rising edge of $\overline{\text{BUSY}}$ latches the result into the 74HC574s.

After the conversion is complete, the ADS7815 sample and hold returns to the sample mode and begins acquiring the input signal for the next conversion. Allowing $4\mu\text{s}$ between falling edges of the convert pulse signal assures accurate acquisition of the analog input.

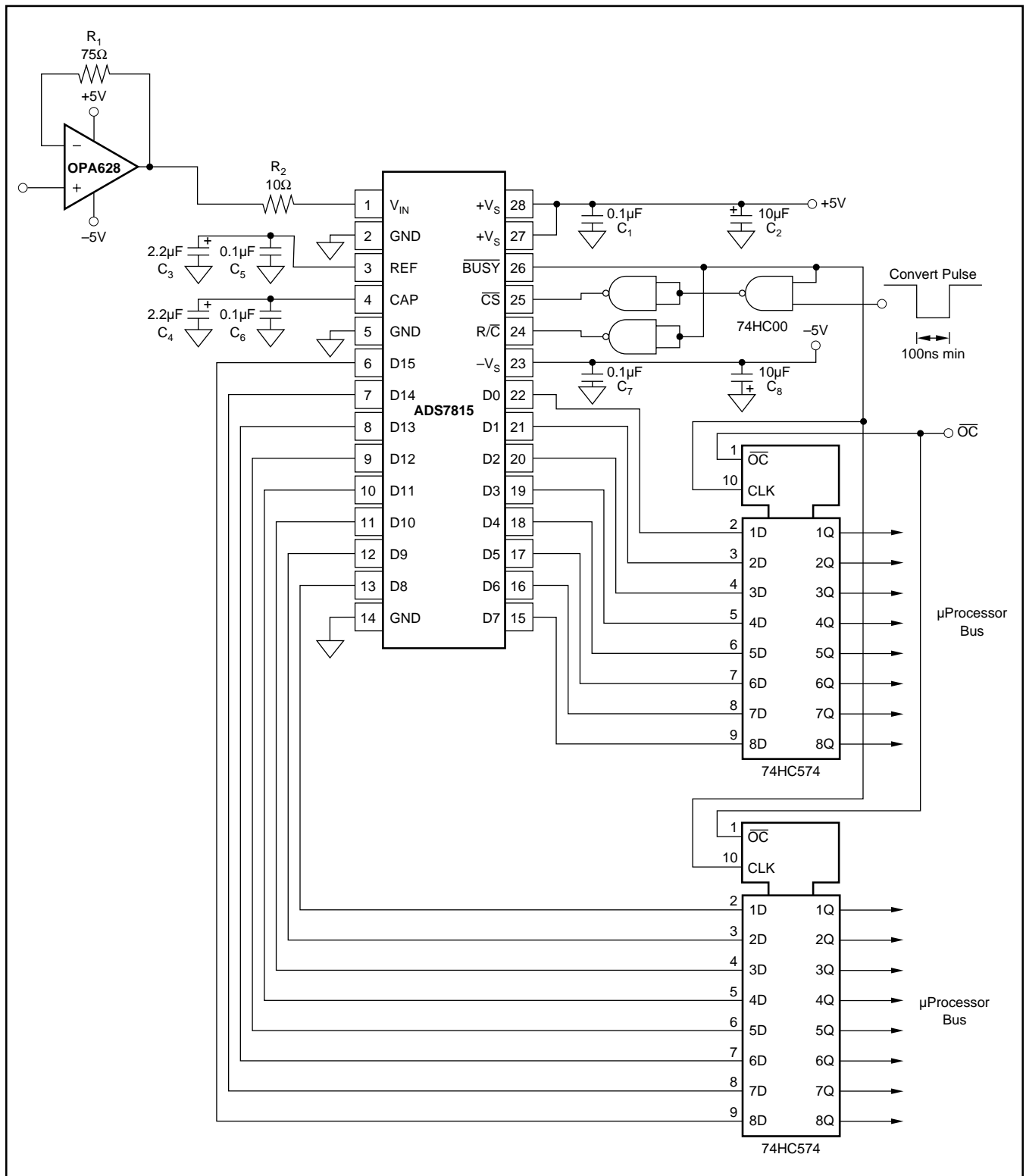

FIGURE 1. Basic Operation.

TIMING

The timing shown in Figure 2 and Table II is the recommended method of operating the ADS7815. The falling edge of \overline{CS} initiates the conversion. During the conversion, the digital outputs are tri-stated and \overline{BUSY} is LOW. Near the end of the conversion, the digital outputs become active with the most recent conversion result. After a brief delay (see time t_{11} in Figure 2 and Table II), \overline{BUSY} rises. The rising edge of \overline{BUSY} is used to latch the digital result in Figure 1.

R/C AND CS

The R/\overline{C} (read/convert) and \overline{CS} signals control the start of conversion and, when a conversion is not in progress, the status of the digital outputs D15 through D0. It is possible to start a conversion by taking \overline{CS} LOW and then taking R/\overline{C} LOW. However, this is not recommended and will result in a significant decrease in signal-to-noise ratio. This is due to

the digital outputs tri-stating while the sample and hold transitions to the hold mode. The change in digital outputs results in noise being coupled onto the hold capacitor.

If a conversion is not in progress or is just about to finish, the digital outputs will be active when R/\overline{C} is HIGH and \overline{CS} is LOW. This is shown in Figure 2 and Figure 3. It is possible to return \overline{CS} HIGH during the initial part of the conversion (as is done with R/\overline{C}) and prevent the digital outputs from becoming active. At a later time, the digital results could be read by taking \overline{CS} LOW. It is also possible to leave R/\overline{C} LOW, take \overline{CS} HIGH during the conversion, and read the results at a later time by taking R/\overline{C} HIGH and \overline{CS} LOW.

Following a conversion, if R/\overline{C} and \overline{CS} are both LOW 250ns after \overline{BUSY} rises, then a new conversion will be initiated without allowing the proper acquisition period for the sample and hold. R/\overline{C} must remain HIGH or \overline{CS} must be taken HIGH within 250ns of \overline{BUSY} rising.

SYMBOL	DESCRIPTION	MIN	TYP	MAX	UNITS
t_1	\overline{CS} to R/\overline{C} Delay			200	ns
t_2	\overline{CS} to \overline{BUSY} Delay		40		ns
t_3	Aperture Delay		40		ns
t_4	\overline{BUSY} LOW		3.3		μ s
t_5	R/\overline{C} LOW to \overline{CS} LOW	100			ns
t_6	\overline{BUSY} HIGH to \overline{CS} HIGH			250	ns
t_7	Bus Access Time		10	83	ns
t_8	Bus Relinquish Time			83	ns
t_9	Throughput Time			4	μ s
t_{10}	Conversion Time		3.3		μ s
t_{11}	Data Valid to \overline{BUSY} HIGH	25	35		ns
t_{12}	\overline{CS} to R/\overline{C} Setup Time	40			ns

TABLE II. Conversion Timing.

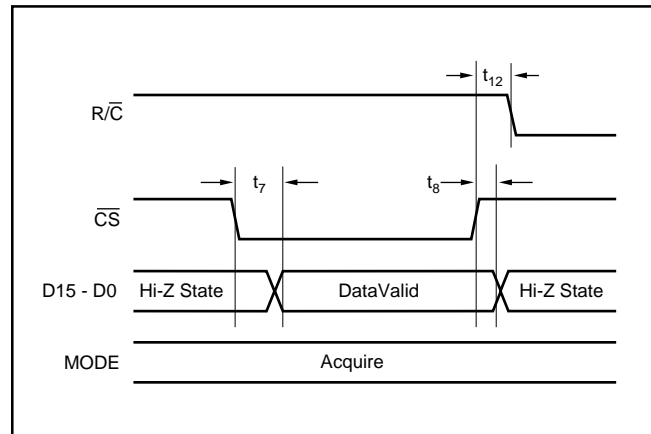

FIGURE 3. Bus Timing.

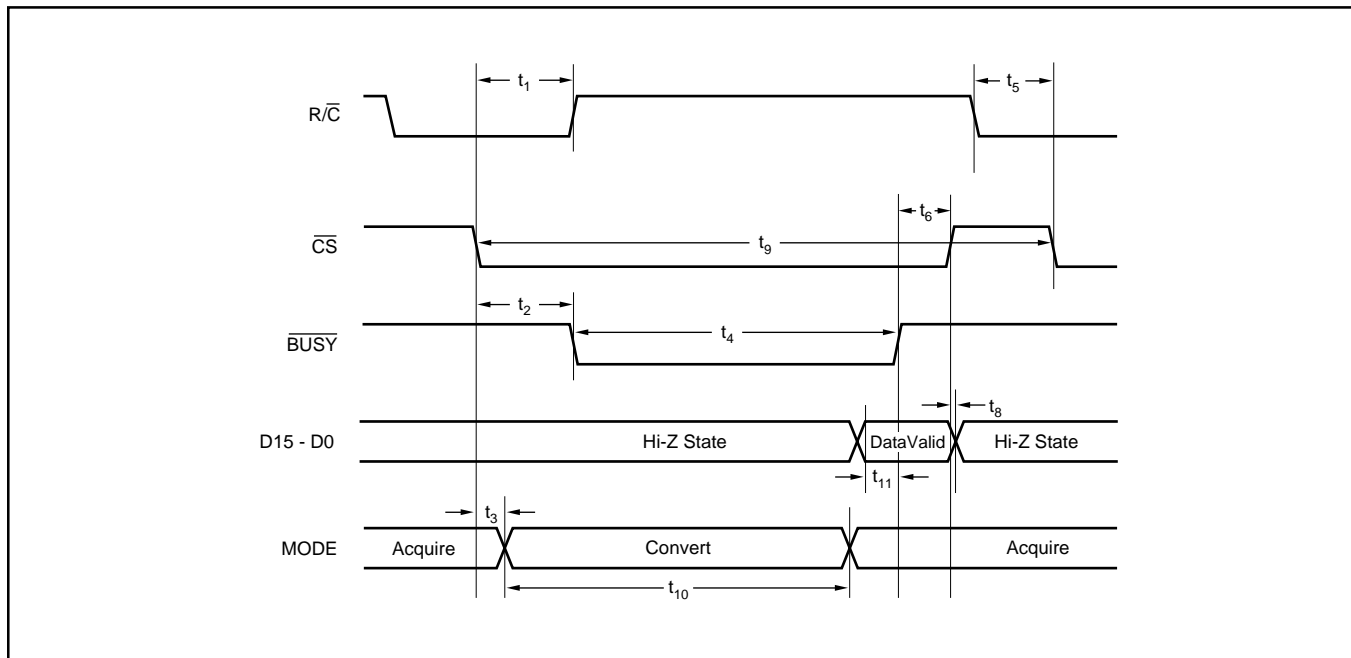

FIGURE 2. ADS7815 Timing.

$\overline{R/C}$ and \overline{CS} should remain static prior to that start of conversion and during the later part of a conversion. To start a conversion, $\overline{R/C}$ should be taken LOW at least 100ns before \overline{CS} is taken LOW. $\overline{R/C}$ and/or \overline{CS} should be taken HIGH during the early part of the conversion, preferably within 200ns of the start of the conversion. If these times are not observed, then there is risk that the transition of these digital signals may affect the conversion result.

The three NAND gates shown in Figure 1 can be used to generate $\overline{R/C}$ and \overline{CS} signals from a single negative going pulse.

BUSY

\overline{BUSY} goes LOW when a conversion is started and remains LOW throughout the conversion. Just prior to \overline{BUSY} going HIGH, the digital outputs become active with the conversion result. Time t_{11} , shown in Figure 2, should provide adequate time for the ADS7815 to drive the digital outputs to a valid logic state before \overline{BUSY} rises. As shown in Figure 1 and 2, the rising edge of \overline{BUSY} can be used to latch the digital result into an external component.

DIGITAL OUTPUT

The ADS7815's digital output is in Binary Two's Complement (BTC) format. Table III shows the relationship between the digital output word and analog input voltage under ideal conditions.

DESCRIPTION	ANALOG INPUT	DIGITAL OUTPUT	
		BINARY TWO'S COMPLEMENT	
		BINARY CODE	HEX CODE
Full Scale Range	$\pm 2.5V$		
Least Significant Bit (LSB)	$76\mu V$		
+Full Scale (2.5V – 1LSB)	2.499924V	0111 1111 1111 1111	7FFF
Midscale	0V	0000 0000 0000 0000	0000
One LSB below Midscale	$-76\mu V$	1111 1111 1111 1111	FFFF
-Full Scale	$-2.5V$	1000 0000 0000 0000	8000

Table III. Ideal Input Voltages and Output Codes.

REFERENCE

The ADS7815 can be operated with the internal 2.5V reference or an external reference. By applying an external reference to the REF pin, the internal reference is bypassed. The reference voltage at REF is buffered internally.

The voltage at the reference input sets the full-scale range of the converter. With the internal 2.5V reference, the input range is $\pm 2.5V$. Thus, the input range of the converter's analog input is simply $\pm V_{REF}$, where V_{REF} is the voltage at the reference input. Because of internal gain and offset error, the input range will not be exactly $\pm V_{REF}$. The full-scale error of the converter with an external reference will typically be 0.25% or less. The bipolar zero error will be similar to that listed in the Electrical Characteristics table. The range for the external reference is 2.3V to 2.7V.

REF PIN

The REF pin itself should be bypassed with a $0.1\mu F$ ceramic capacitor in parallel with a $2.2\mu F$ tantalum capacitor. While both capacitors should be physically close to the ADS7815, it is very important that the ceramic capacitor be placed as close as possible.

The REF voltage should not be used to drive a large load or any load which is dynamic. A large load will reduce the reference voltage and the corresponding input range of the converter. A dynamic load will modulate the reference voltage and this modulation will be present in the converter's output data.

CAP PIN

The voltage on the CAP pin is the output of the reference buffer. This pin should be bypassed with a $0.1\mu F$ ceramic capacitor in parallel with a $2.2\mu F$ tantalum capacitor. While both capacitors should be physically close to the ADS7815, it is very important that the ceramic capacitor be placed as close as possible.

The CAP pin connects to the internal reference buffer and directly to the binary weighted capacitor array of the converter. Thus, the signal at the CAP pin has high-frequency glitches which occur at each bit decision. For this reason, the CAP voltage should not be used to provide a reference voltage for external circuitry.

LAYOUT

The layout of the ADS7815 and accompanying components will be critical for optimum performance. Use of an analog ground plane is essential. Use of +5V and -5V power planes is not critical as long as the supplies are well bypassed, and the traces connecting +5V and -5V to the power connector are not too long or too thin.

The two +V_S power pins of the ADS7815 must be tied together. The voltage source for these pins should also power the input buffer and the 74HC00 shown in Figure 1. This supply should separate from the positive +5V supply for the system's digital logic

Three ground pins are present on the ADS7815: pin 2, pin 5, and pin 14. These should all be tied to the analog ground plane. The analog ground plane should extend underneath all analog signal conditioning components and up to the 74HC574s (or equivalent components) shown in Figure 1. The 74HC574s should not be located more than several inches from the ADS7815.

The ground for the 74HC574s should be connected to the digital ground. The analog ground plane should extend up to the 74HC574s but should be kept at least 1/4" (6mm) distant from the digital ground plane (if present). The analog and digital grounds planes should not overlap at any point.

INTERMEDIATE LATCHES

The 74HC574s shown in Figure 1 isolate the ADS7815 from digital signals on a microprocessor, digital signal processor (DSP), or microcontroller bus. This is necessary because of the precision needed within the ADS7815. The weight of a

single LSB in the ADS7815 is 76 μ V, and the comparator must be able to resolve differences in voltage to this level. External digital signals which transition during the conversion can easily couple onto the substrate and produce voltages larger than this.

In place of the 74HC574s, it might be possible to use a FIFO or similar type of memory device. For the majority of systems, it will be difficult to go directly from the ADS7815 into a microcontroller or DSP even if the ADS7815 is not connected to shared bus. The reason for this is that during a conversion, the ADS7815 outputs are tri-stated. The only chance to read the outputs are during the acquisition period. And, this is not recommended if the data will be read just prior to the converter going into the hold mode.

SIGNAL CONDITIONING

The ADS7815 input essentially consists of a switch and a capacitor. In the acquisition or sample mode, the switch is closed and the input signal drives the capacitor directly. When a conversion is started, the switch is opened capturing the input signal at that moment. This voltage is held on the capacitor for the remainder of the conversion.

While this provides for a wide bandwidth sample and hold function and results in excellent AC performance, this architecture requires a high bandwidth, precision op amp to drive the analog input. The op amp and configuration shown in Figure 1 is highly recommended. The amplifier should be placed within 1 to 2 inches (25 to 50mm) of the ADS7815, and the layout guidelines in the OPA628 data sheet should be strictly followed.

Revision History

DATE	REVISION	PAGE	SECTION	DESCRIPTION
12/06	B	1	Features	Changed from "84dB min SINAD" to "82dB min SINAD WITH 100kHz INPUT"
11/06	A	—	Entire Document	Updated document format to current standard; some page layout changed.
		3	Electrical Characteristics	Changed Total Harmonic Distortion max value from -96 to -94.
				Changed Signal-to-(Noise+Distortion) min value from 84 to 82.
				Changed Signal-to-Noise min value from 84 to 82.

NOTE: Page numbers for previous revisions may differ from page numbers in the current version.

PACKAGING INFORMATION

Orderable Device	Status ⁽¹⁾	Package Type	Package Drawing	Pins	Package Qty	Eco Plan ⁽²⁾	Lead/ Ball Finish	MSL Peak Temp ⁽³⁾	Samples (Requires Login)
ADS7815U	ACTIVE	SOIC	DW	28	20	Green (RoHS & no Sb/Br)	CU NIPDAU	Level-3-260C-168 HR	
ADS7815U/1K	ACTIVE	SOIC	DW	28	1000	Green (RoHS & no Sb/Br)	CU NIPDAU	Level-3-260C-168 HR	
ADS7815U/1KE4	ACTIVE	SOIC	DW	28	1000	Green (RoHS & no Sb/Br)	CU NIPDAU	Level-3-260C-168 HR	
ADS7815UE4	ACTIVE	SOIC	DW	28	20	Green (RoHS & no Sb/Br)	CU NIPDAU	Level-3-260C-168 HR	
ADS7815UG4	ACTIVE	SOIC	DW	28	20	Green (RoHS & no Sb/Br)	CU NIPDAU	Level-3-260C-168 HR	

⁽¹⁾ The marketing status values are defined as follows:

ACTIVE: Product device recommended for new designs.

LIFEBUY: TI has announced that the device will be discontinued, and a lifetime-buy period is in effect.

NRND: Not recommended for new designs. Device is in production to support existing customers, but TI does not recommend using this part in a new design.

PREVIEW: Device has been announced but is not in production. Samples may or may not be available.

OBSOLETE: TI has discontinued the production of the device.

⁽²⁾ Eco Plan - The planned eco-friendly classification: Pb-Free (RoHS), Pb-Free (RoHS Exempt), or Green (RoHS & no Sb/Br) - please check <http://www.ti.com/productcontent> for the latest availability information and additional product content details.

TBD: The Pb-Free/Green conversion plan has not been defined.

Pb-Free (RoHS): TI's terms "Lead-Free" or "Pb-Free" mean semiconductor products that are compatible with the current RoHS requirements for all 6 substances, including the requirement that lead not exceed 0.1% by weight in homogeneous materials. Where designed to be soldered at high temperatures, TI Pb-Free products are suitable for use in specified lead-free processes.

Pb-Free (RoHS Exempt): This component has a RoHS exemption for either 1) lead-based flip-chip solder bumps used between the die and package, or 2) lead-based die adhesive used between the die and leadframe. The component is otherwise considered Pb-Free (RoHS compatible) as defined above.

Green (RoHS & no Sb/Br): TI defines "Green" to mean Pb-Free (RoHS compatible), and free of Bromine (Br) and Antimony (Sb) based flame retardants (Br or Sb do not exceed 0.1% by weight in homogeneous material)

⁽³⁾ MSL, Peak Temp. -- The Moisture Sensitivity Level rating according to the JEDEC industry standard classifications, and peak solder temperature.

Important Information and Disclaimer: The information provided on this page represents TI's knowledge and belief as of the date that it is provided. TI bases its knowledge and belief on information provided by third parties, and makes no representation or warranty as to the accuracy of such information. Efforts are underway to better integrate information from third parties. TI has taken and continues to take reasonable steps to provide representative and accurate information but may not have conducted destructive testing or chemical analysis on incoming materials and chemicals. TI and TI suppliers consider certain information to be proprietary, and thus CAS numbers and other limited information may not be available for release.

In no event shall TI's liability arising out of such information exceed the total purchase price of the TI part(s) at issue in this document sold by TI to Customer on an annual basis.

TAPE AND REEL INFORMATION



QUADRANT ASSIGNMENTS FOR PIN 1 ORIENTATION IN TAPE



*All dimensions are nominal

Device	Package Type	Package Drawing	Pins	SPQ	Reel Diameter (mm)	Reel Width W1 (mm)	A0 (mm)	B0 (mm)	K0 (mm)	P1 (mm)	W (mm)	Pin1 Quadrant
ADS7815U/1K	SOIC	DW	28	1000	330.0	32.4	11.35	18.67	3.1	16.0	32.0	Q1

TAPE AND REEL BOX DIMENSIONS



*All dimensions are nominal

Device	Package Type	Package Drawing	Pins	SPQ	Length (mm)	Width (mm)	Height (mm)
ADS7815U/1K	SOIC	DW	28	1000	346.0	346.0	49.0

DW (R-PDSO-G28)

PLASTIC SMALL OUTLINE

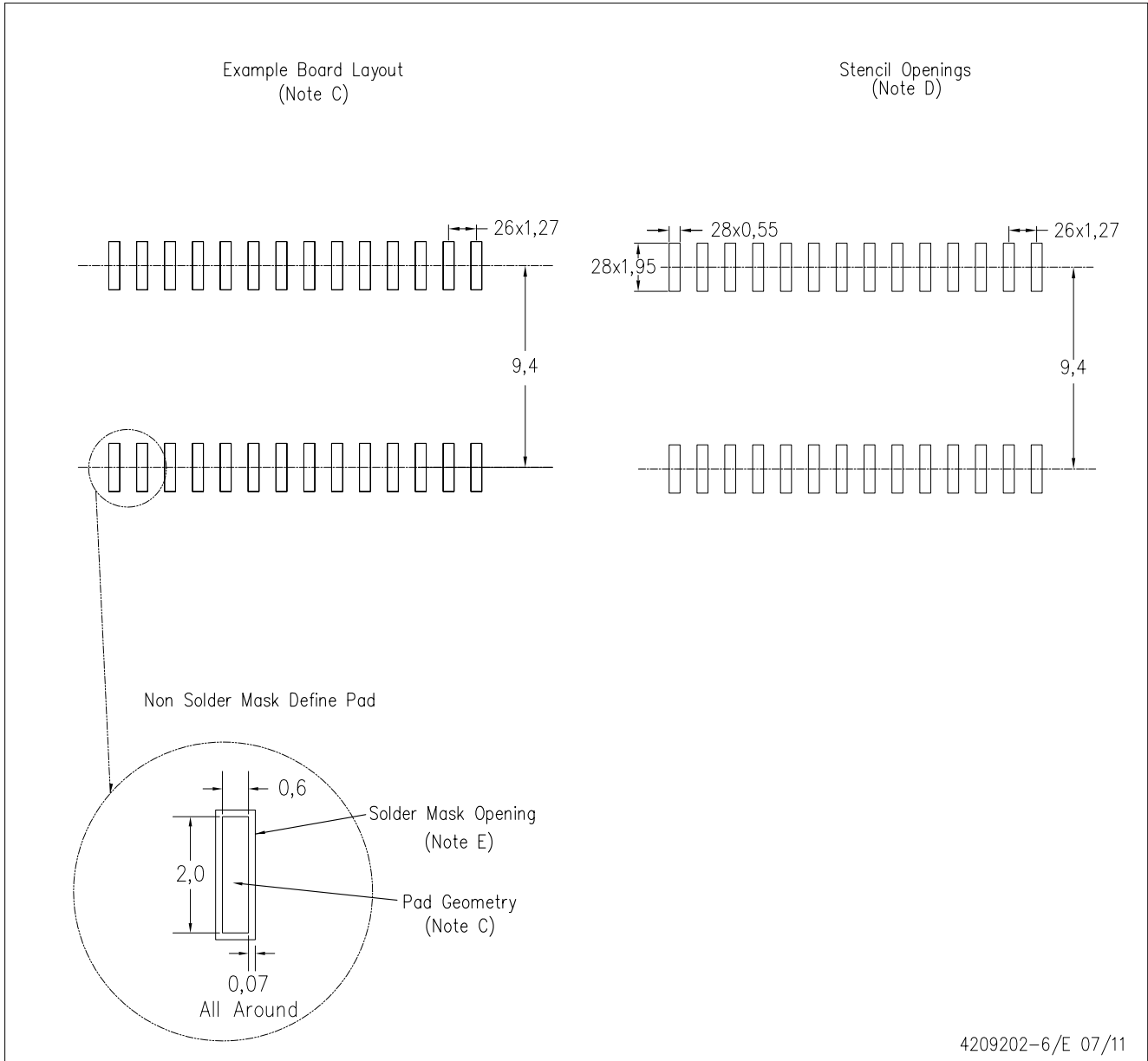

4209202-6/E 07/11

- NOTES:
- A. All linear dimensions are in millimeters.
 - B. This drawing is subject to change without notice.
 - C. Refer to IPC7351 for alternate board design.
 - D. Laser cutting apertures with trapezoidal walls and also rounding corners will offer better paste release. Customers should contact their board assembly site for stencil design recommendations. Refer to IPC-7525
 - E. Customers should contact their board fabrication site for solder mask tolerances between and around signal pads.

IMPORTANT NOTICE

Texas Instruments Incorporated and its subsidiaries (TI) reserve the right to make corrections, modifications, enhancements, improvements, and other changes to its products and services at any time and to discontinue any product or service without notice. Customers should obtain the latest relevant information before placing orders and should verify that such information is current and complete. All products are sold subject to TI's terms and conditions of sale supplied at the time of order acknowledgment.

TI warrants performance of its hardware products to the specifications applicable at the time of sale in accordance with TI's standard warranty. Testing and other quality control techniques are used to the extent TI deems necessary to support this warranty. Except where mandated by government requirements, testing of all parameters of each product is not necessarily performed.

TI assumes no liability for applications assistance or customer product design. Customers are responsible for their products and applications using TI components. To minimize the risks associated with customer products and applications, customers should provide adequate design and operating safeguards.

TI does not warrant or represent that any license, either express or implied, is granted under any TI patent right, copyright, mask work right, or other TI intellectual property right relating to any combination, machine, or process in which TI products or services are used. Information published by TI regarding third-party products or services does not constitute a license from TI to use such products or services or a warranty or endorsement thereof. Use of such information may require a license from a third party under the patents or other intellectual property of the third party, or a license from TI under the patents or other intellectual property of TI.

Reproduction of TI information in TI data books or data sheets is permissible only if reproduction is without alteration and is accompanied by all associated warranties, conditions, limitations, and notices. Reproduction of this information with alteration is an unfair and deceptive business practice. TI is not responsible or liable for such altered documentation. Information of third parties may be subject to additional restrictions.

Resale of TI products or services with statements different from or beyond the parameters stated by TI for that product or service voids all express and any implied warranties for the associated TI product or service and is an unfair and deceptive business practice. TI is not responsible or liable for any such statements.

TI products are not authorized for use in safety-critical applications (such as life support) where a failure of the TI product would reasonably be expected to cause severe personal injury or death, unless officers of the parties have executed an agreement specifically governing such use. Buyers represent that they have all necessary expertise in the safety and regulatory ramifications of their applications, and acknowledge and agree that they are solely responsible for all legal, regulatory and safety-related requirements concerning their products and any use of TI products in such safety-critical applications, notwithstanding any applications-related information or support that may be provided by TI. Further, Buyers must fully indemnify TI and its representatives against any damages arising out of the use of TI products in such safety-critical applications.

TI products are neither designed nor intended for use in military/aerospace applications or environments unless the TI products are specifically designated by TI as military-grade or "enhanced plastic." Only products designated by TI as military-grade meet military specifications. Buyers acknowledge and agree that any such use of TI products which TI has not designated as military-grade is solely at the Buyer's risk, and that they are solely responsible for compliance with all legal and regulatory requirements in connection with such use.

TI products are neither designed nor intended for use in automotive applications or environments unless the specific TI products are designated by TI as compliant with ISO/TS 16949 requirements. Buyers acknowledge and agree that, if they use any non-designated products in automotive applications, TI will not be responsible for any failure to meet such requirements.

Following are URLs where you can obtain information on other Texas Instruments products and application solutions:

Products

Audio	www.ti.com/audio
Amplifiers	amplifier.ti.com
Data Converters	dataconverter.ti.com
DLP® Products	www.dlp.com
DSP	dsp.ti.com
Clocks and Timers	www.ti.com/clocks
Interface	interface.ti.com
Logic	logic.ti.com
Power Mgmt	power.ti.com
Microcontrollers	microcontroller.ti.com
RFID	www.ti-rfid.com
RF/IF and ZigBee® Solutions	www.ti.com/lprf

Applications

Communications and Telecom	www.ti.com/communications
Computers and Peripherals	www.ti.com/computers
Consumer Electronics	www.ti.com/consumer-apps
Energy and Lighting	www.ti.com/energy
Industrial	www.ti.com/industrial
Medical	www.ti.com/medical
Security	www.ti.com/security
Space, Avionics and Defense	www.ti.com/space-avionics-defense
Transportation and Automotive	www.ti.com/automotive
Video and Imaging	www.ti.com/video
Wireless	www.ti.com/wireless-apps

TI E2E Community Home Page

e2e.ti.com

Mailing Address: Texas Instruments, Post Office Box 655303, Dallas, Texas 75265
Copyright © 2011, Texas Instruments Incorporated