

FEATURES

- 1. Compact type for automotives**
We successfully developed a power type that is the same size as our CT relay.
- 2. 30 A maximum switching capacity**
Switching of 30 A motor loads is possible due to change of COM spring material and other improvements.
- 3. Still top-of-its-class for silent operation**
Maintains equally silent operation as our CT relay (ACT).
- 4. Sealed type**
Sealed type makes automatic cleaning possible.

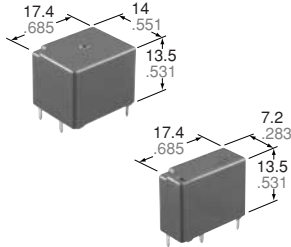

Compliance with RoHS Directive

APPLICATIONS

Power windows, Powered seats, Auto door lock, Slide door closers, Power sunroof, etc.

10-terminal layout

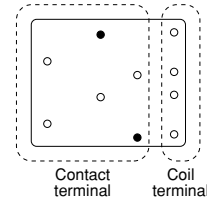

*8-terminal type has no ● terminals.

SPECIFICATIONS

Contact

Arrangement	1 Form C×2, 1 Form C	
Contact material	Ag alloy (Cadmium free)	
Initial contact resistance (Initial) (By voltage drop 6 V DC 1 A)	Typ. 7 mΩ (N.O.) Typ. 10 mΩ (N.C.)	
Rating	Nominal switching capacity	N.O.: 30 A 14 V DC N.C.: 10 A 14 V DC
	Max. carrying current (N.O.)	40 A for 2 minutes, 25 A for 1 hour (at 20°C 68°F) 35 A for 2 minutes, 20 A for 1 hour (at 85°C 185°F)
	Min. switching capacity#1	1 A 12 V DC
Expected life (min. operation)	Mechanical (at 120 cpm) Min. 10 ⁶	
	Electrical	Resistive load Min. 5×10 ⁴ *1
		Motor load Min. 10 ⁵ *2 (free) Min. 5×10 ⁴ *3 (lock)

Coil

Nominal operating power	1,000 mW
-------------------------	----------

#1 This value can change due to the switching frequency, environmental conditions, and desired reliability level, therefore it is recommended to check this with the actual load.

Remarks

- *1 At nominal switching capacity, operating frequency: 1s ON, 9s OFF
- *2 N.O.: at 7 A (steady), 30 A (inrush)/N.C.: at 15 A (brake) 14 V DC, operating frequency: 0.5s ON, 9.5s OFF
- *3 At 30A 14 V DC (Motor lock), operating frequency: 0.5s ON, 9.5s OFF
- *4 Measurement at same location as "Initial breakdown voltage" section
- *5 Detection current: 10mA
- *6 Excluding contact bounce time
- *7 Half-wave pulse of sine wave: 11ms; detection: 10μs
- *8 Half-wave pulse of sine wave: 6ms
- *9 Detection time: 10μs
- *10 Time of vibration for each direction;
X, Y, direction: 2 hours
Z direction: 4 hours



*11 Refer to Conditions for operation, transport and storage mentioned in AMBIENT ENVIRONMENT.
Please inquire if you will be using the relay in a high temperature atmosphere (110°C 230°F).

* If the relay is used continuously for long periods of time with coils on both sides in an energized condition, breakdown might occur due to abnormal heating depending on the carrying condition. Therefore, please inquire when using with a circuit that causes an energized condition on both sides simultaneously.

Characteristics

Max. operating speed (at nominal switching capacity)	6 cpm	
Initial insulation resistance*4	Min. 100 MΩ (at 500 V DC)	
Initial breakdown voltage*5	Between open contacts	500 Vrms for 1 min.
	Between contacts and coil	500 Vrms for 1 min.
Operate time*6 (at nominal voltage) (at 20°C 68°F)	Max. 10ms (Initial)	
Release time*6 (at nominal voltage) (at 20°C 68°F)	Max. 10ms (Initial)	
Shock resistance	Functional*7	Min. 100 m/s ² {10G}
	Destructive*8	Min. 1,000 m/s ² {100G}
Vibration resistance	Functional*9	10 Hz to 100 Hz, Min. 44.1m/s ² {4.5G}
	Destructive*10	10 Hz to 500 Hz, Min. 44.1m/s ² {4.5G}
Conditions for operation, transport and storage*11 (Not freezing and condensing at low temperature)	Ambient temp	-40°C to +85°C -40°F to +185°F
	Humidity	5% R.H. to 85% R.H.
Mass	Twin type: approx. 8.0g .28oz 1 Form C type: approx. 4.0g .14oz	

TYPES AND COIL DATA (at 20°C 68°F)

Standard packing; 1 Form C: Carton(tube package) 30pcs. Case 1,500pcs.
1 Form C × 2: Carton(tube package) 30pcs. Case 900pcs.

Contact arrangement	Part No.	Nominal voltage, V DC	Pick-up voltage, V DC (Initial)	Drop-out voltage, V DC (Initial)	Coil resistance, Ω	Nominal operating current, mA	Nominal operating power, mW	Usable voltage range, V DC
1 Form C	ACTP112	12	Max. 7.2	Min. 1.0	144±10%	83.3±10%	1,000	10 to 16
1 Form C × 2 (8 terminals type)	ACTP212	12	Max. 7.2	Min. 1.0	144±10%	83.3±10%	1,000	10 to 16
1 Form C × 2 (10 terminals type)	ACTP512	12	Max. 7.2	Min. 1.0	144±10%	83.3±10%	1,000	10 to 16

* Other pick-up voltage types are also available. Please contact us for details.

DIMENSIONS

mm inch

1. Twin type (8 terminals)

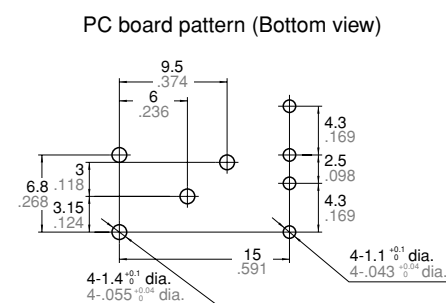
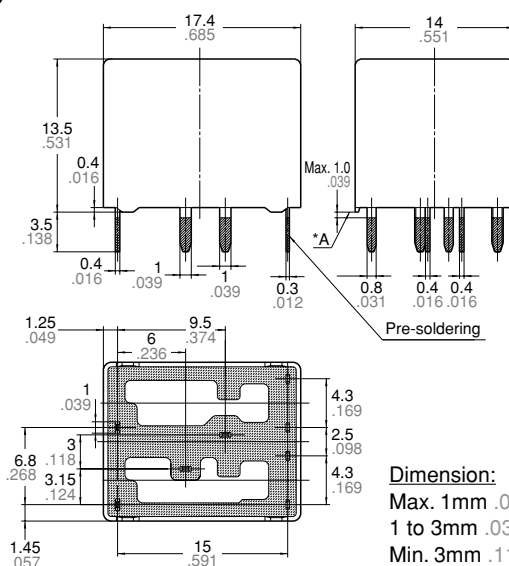

Tolerance: ±0.1 ±0.004

Schematic (Bottom view)

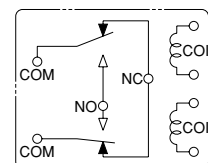

Dimension:
Max. 1mm .039 inch:
1 to 3mm .039 to .118 inch: ±0.2 ±0.008
Min. 3mm .118 inch: ±0.3 ±0.012

Tolerance
±0.1 ±0.004
±0.2 ±0.008
±0.3 ±0.012

* Dimensions (thickness and width) of terminal specified in this catalog is measured before pre-soldering. Intervals between terminals is measured at A surface level.

2. Twin type (10 terminals)

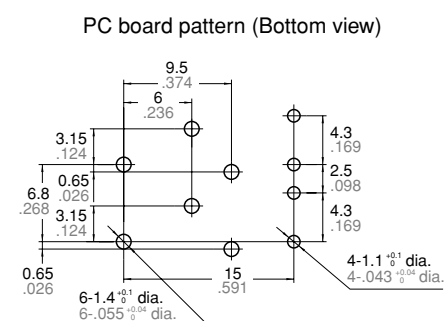
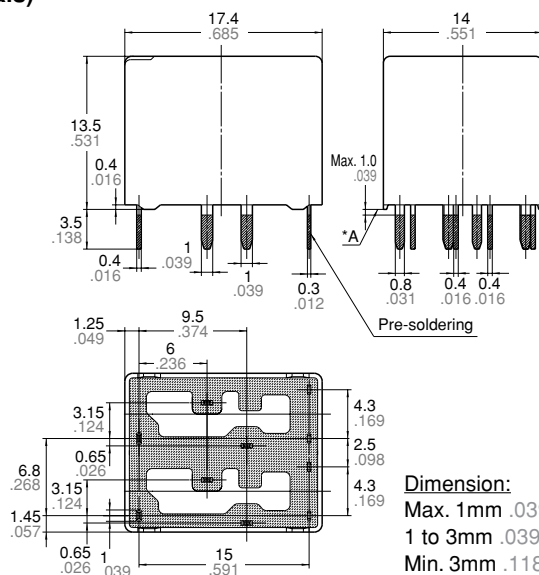

Tolerance: ±0.1 ±0.004

Schematic (Bottom view)

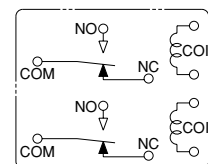

Dimension:
Max. 1mm .039 inch:
1 to 3mm .039 to .118 inch: ±0.2 ±0.008
Min. 3mm .118 inch: ±0.3 ±0.012

Tolerance
±0.1 ±0.004
±0.2 ±0.008
±0.3 ±0.012

* Dimensions (thickness and width) of terminal specified in this catalog is measured before pre-soldering. Intervals between terminals is measured at A surface level.

CT (ACTP)

3. Single type (1 Form C)

mm inch

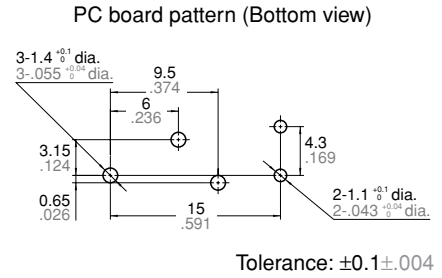
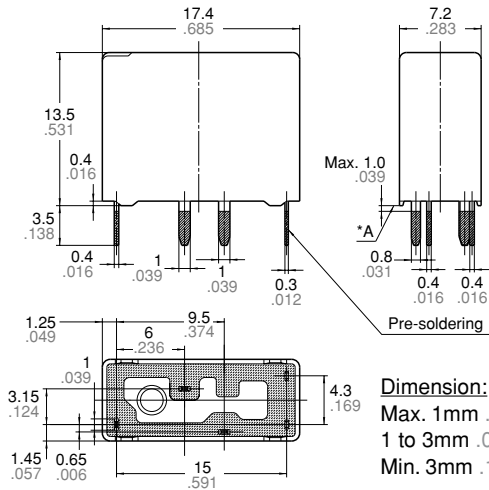

Schematic (Bottom view)

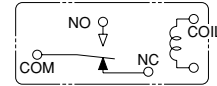

* Dimensions (thickness and width) of terminal specified in this catalog is measured before pre-soldering. Intervals between terminals is measured at A surface level.

EXAMPLE OF CIRCUIT

Forward/reverse control circuits of DC motor for power windows

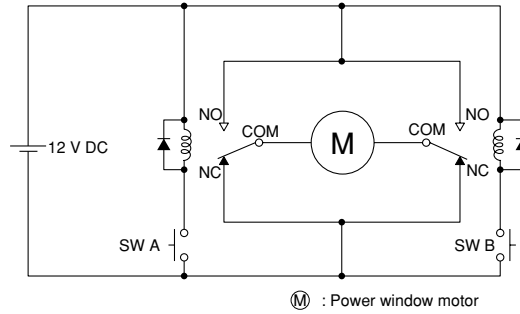

REFERENCE DATA

1-(1). Coil temperature rise (at room temperature)

Sample: ACTP212, 3pcs.
Contact carrying current: 0A, 10A, 20A

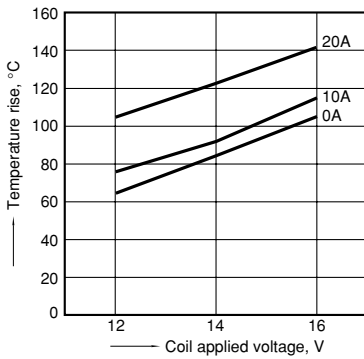

1-(2). Coil temperature rise (at 85°C 185°F)

Sample: ACTP212, 3pcs.
Contact carrying current: 0A, 10A, 20A

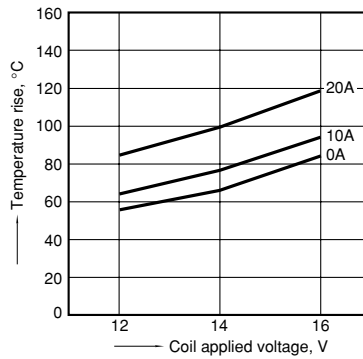

2. Ambient temperature and operating voltage range

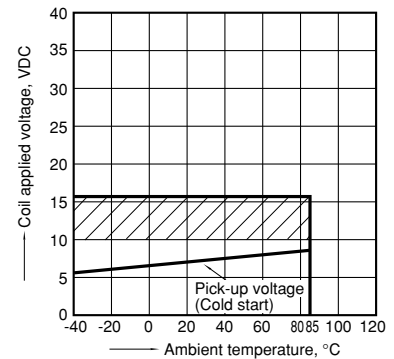

3. Distribution of pick-up and drop-out voltage

Sample: ACTP212, 40pcs.

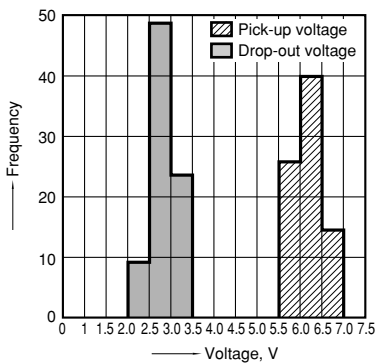

4. Distribution of operate and release time

Sample: ACTP212, 40pcs.

* Without diode

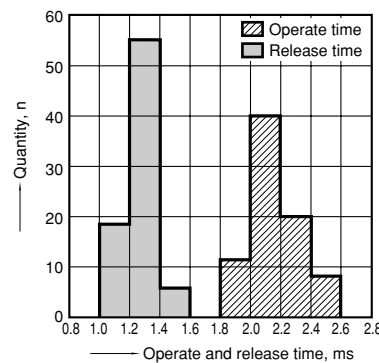

5. Electrical life test (Motor free)

Sample: ACTP212, 3pcs.
 Load: 7A steady, Inrush 30A
 Brake current: 15A 14V DC,
 Power window motor actual load (free condition)
 Operating frequency: (ON : OFF = 0.5s : 9.5s)
 Ambient temperature: Room temperature
 Circuit:

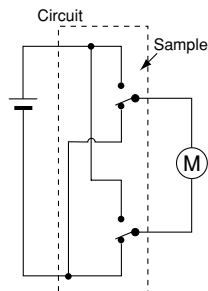

Change of pick-up and drop-out voltage

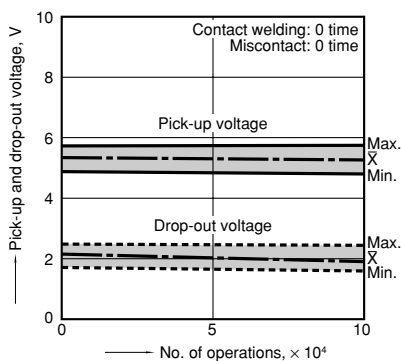

Change of contact resistance

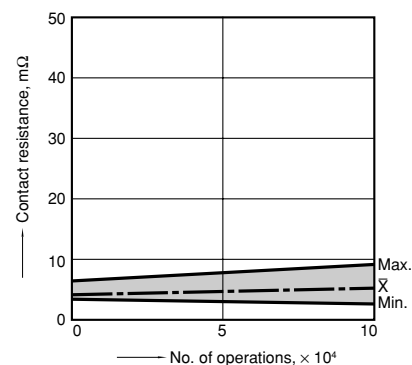

Load current waveform

Inrush current: 30A, Steady current: 7A
 Brake current: 15A

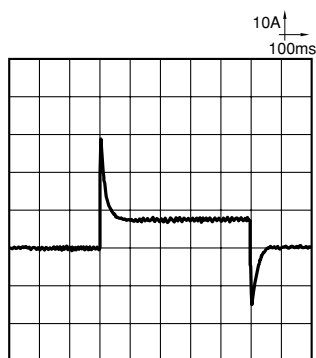

6. Electrical life test (Motor lock)

Sample: ACTP212, 3pcs.
 Load: 30A 14V DC
 Switching frequency: (ON : OFF = 0.5s : 9.5s)
 Ambient temperature: Room temperature
 Circuit:

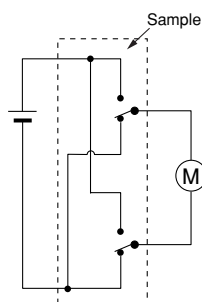

Change of pick-up and drop-out voltage

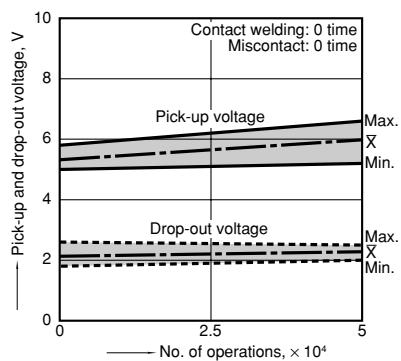

Change of contact resistance

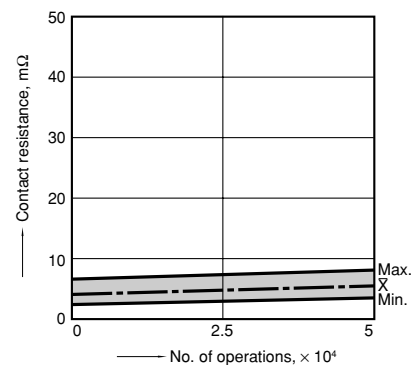

Load current waveform

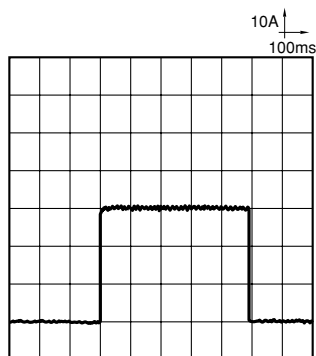

For Cautions for Use, see Relay Technical Information.