

400 kHz, High Accuracy Current Sensor with Pin-Selectable Gains and Adjustable Overcurrent Fast Fault in SOICW-16 Package

FEATURES AND BENEFITS

- Low internal primary conductor resistance (0.27 mΩ) for better power efficiency and low heat dissipation
- High operating bandwidth and response time to enable reliable current measurements in applications where fast control loops are used or high-speed currents are monitored
 - 400 kHz bandwidth
 - 1.1 μs typical response time
- High accuracy current measurements
 - 1.5 % maximum sensitivity error over temperature
 - 10 mV maximum offset voltage over temperature
 - Non-ratiometric operation with V_{REF} output
 - Differential sensing for high immunity to external magnetic fields
 - No magnetic hysteresis
- Adjustable fast overcurrent fault
 - 1 μs typical response time
 - Pin adjustable threshold
- Externally configurable gain settings using two logic pins
 - Four adjustable gain levels for increased design flexibility

Continued on the next page...

PACKAGE:

16-pin SOICW
(suffix MC)

Not to scale

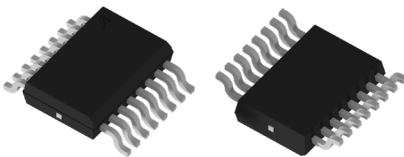

DESCRIPTION

The ACS37002LMC is a fully integrated Hall-effect current sensor in an SOICW-16 package that is factory-trimmed to provide high accuracy over the entire operating range without the need for customer programming. The current is sensed differentially by two Hall plates that subtract out interfering external common-mode magnetic fields.

The package construction provides high isolation by magnetically coupling the field generated by the current in the conductor to the monolithic Hall sensor IC which has no physical connection to the integrated current conductor. The MC package is optimized for high isolation with withstand voltage, 5 kV_{RMS}, and 0.27 mΩ conductor resistance, ideal for low power dissipation constraints.

The ACS37002LMC has functional features that are externally configurable and robust without the need for programming. Two logic gain selection pins can be used to configure the device to one of four defined sensitivities and corresponding current ranges. A fast overcurrent fault output provides short-circuit detection for system protection with a fault threshold that is proportional to the current range and can be set with an analog input. The reference pin provides a stable voltage that corresponds to the 0 A output voltage. This reference voltage allows for differential measurements as well as a device-referred voltage to set the overcurrent fault threshold.

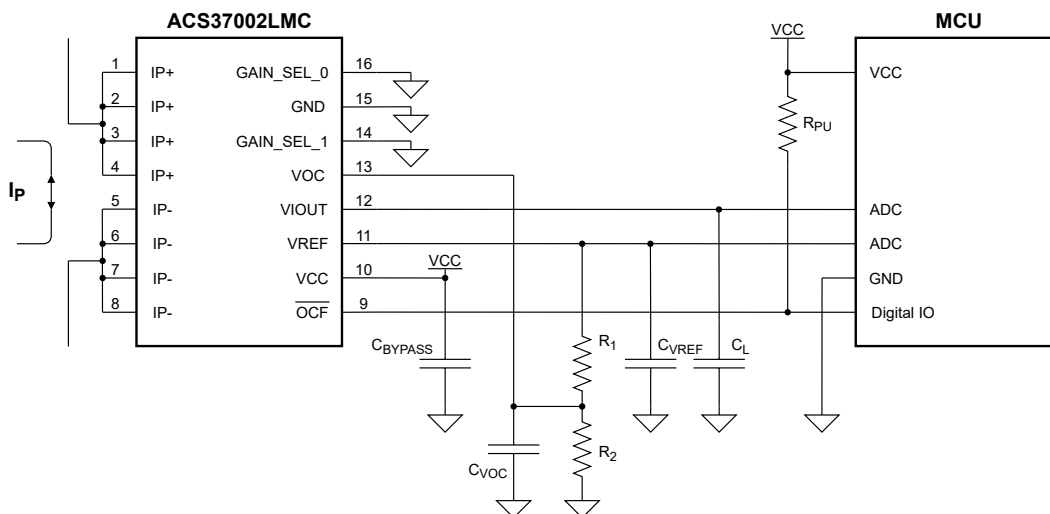

Figure 1: Typical Bidirectional Application
For more application circuits, refer to the Application and Theory section

FEATURES AND BENEFITS (continued)

- Enabling measurement ranges from 33 to 180 A in both unidirectional and bidirectional modes
- UL60950-1 (ed. 2) and UL 62368 (ed. 1) certification, highly isolated compact SOICW-16 surface mount package (MC)
 - 5 kV_{RMS} rated isolation voltage
 - 1144 V_{RMS} / 1618 V_{DC} basic isolation voltages
 - 572 V_{RMS} / 809 V_{DC} reinforced isolation voltages
- Wide operating temperature, -40°C to 150°C
- AEC-Q100 qualified



SELECTION GUIDE

Part Number <small>(click number to go to Performance Characteristics)</small>	Current Sensing Range, I _{PR} (A)	Sensitivity [1] (mV/A)	Nominal V _{CC} (V)	Optimized Temp. Range T _A (°C)	Packing [2]
ACS37002LMCATR-050B5	±33.3, ±40, ±50, ±66.7	60, 50, 40, 30	5	-40 to 150	1000 pieces per 13-inch reel
ACS37002LMCATR-066B5	±66.7, ±80, ±100, ±133.3	30, 25, 20, 15			
ACS37002LMCATR-090B5	±90, ±108, ±135, ±180	22.2, 18.5, 14.8, 11.1			
ACS37002LMCATR-050U5	33.3, 40, 50, 66.7	120, 100, 80, 60			
ACS37002LMCATR-050B3	±33.3, ±40, ±50, ±66.7	39.6, 33, 26.4, 19.8	3.3		

[1] Refer to the part specific performance characteristics sections for Gain_Sel configuration.

[2] Contact Allegro for additional options.

Naming Specification:

ACS 37002 L MCA TR – 050 B 5

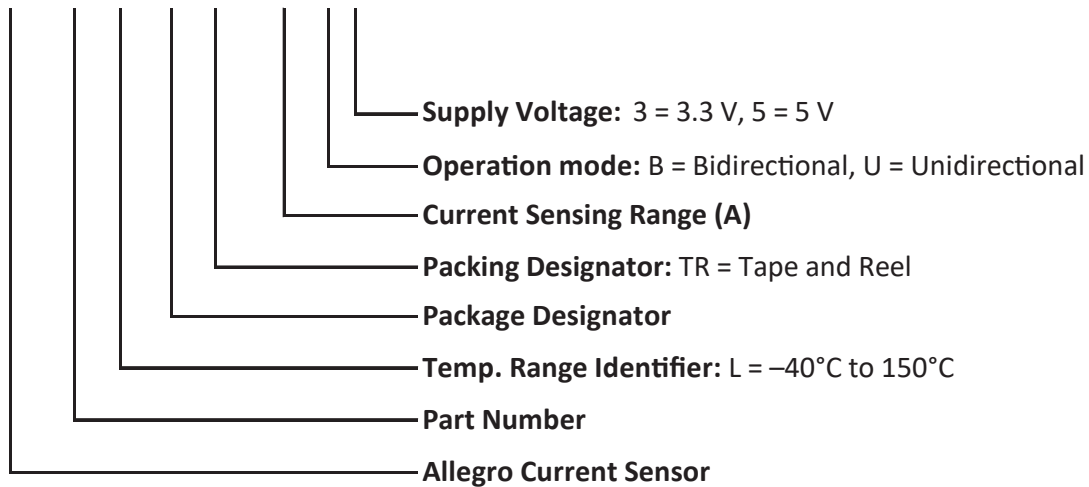

Table of Contents

Features and Benefits.....	1	Gain Selection Pins.....	19
Description.....	1	Full Scale (FS).....	19
Packages.....	1	Nonlinearity (E_{LIN}).....	19
Selection Guide.....	2	Total Output Error (E_{TOT}).....	20
Absolute Maximum Ratings.....	4	Power Supply Offset Error (V_{PS}).....	20
Isolation Characteristics.....	4	Offset Power Supply Rejection Ratio ($PSRR_O$).....	20
Pinout Diagram and Terminal List.....	5	Power Supply Sensitivity Error (E_{PS}).....	20
Functional Block Diagram.....	6	Sensitivity Power Supply Rejection Ratio ($PSRR_S$).....	20
Common Electrical Characteristics.....	7	Fault Behavior.....	21
Performance Characteristics.....	10	Overcurrent Fault (OCF).....	21
Functional Description.....	15	Overcurrent Fault Operating Range/Point (I_{OCF-OR} , I_{OCF-OP}).....	21
Power-On Reset Operation.....	15	Overcurrent Fault Hysteresis ($I_{OCF-Hyst}$).....	21
Power-On.....	15	Voltage Overcurrent Pin (VOC).....	21
Power-Off.....	15	Overcurrent Fault Error (E_{OCF}).....	22
Power-On Timing.....	15	Overcurrent Fault Response Time (t_{OCF}).....	22
Power-On Reset (POR).....	15	Overcurrent Fault Reaction Time (t_{OCF-R}).....	22
Power-On Delay (t_{POD}).....	15	Overcurrent Fault Mask Time ($t_{OCF-MASK}$).....	22
Overvoltage Detection.....	15	Overcurrent Fault Hold Time ($t_{OCF-HOLD}$).....	22
Overvoltage Detection Voltage Thresholds ($V_{OVD(H/L)}$).....	15	Overcurrent Fault Persist.....	22
Overvoltage Detection Hysteresis ($V_{OVD(Hys)}$).....	15	OCF Disable.....	22
Overvoltage Enable and Disable Time ($t_{OVD(E/D)}$).....	15	Dynamic Response Parameters.....	23
Absolute Maximum Ratings.....	17	Propagation Time (t_{PD}).....	23
Forward and Reverse Supply Voltage.....	17	Rise Time (t_r).....	23
Forward and Reverse Output Voltage.....	17	Response Time ($t_{RESPONSE}$).....	23
Forward and Reverse Input Voltage.....	17	Overshoot.....	23
Output Source and Sink Current.....	17	Settling Time.....	23
Ambient Temperature (T_A).....	17	Temperature Compensation.....	23
Definitions of Operating and Performance Characteristics.....	18	Temperature Compensation Update Rate.....	23
Zero Current Voltage Output ($V_{IOUT(Q)}$, QVO).....	18	Application and Theory.....	24
QVO Temperature Drift (V_{QE}).....	18	Application Circuits.....	24
Reference Voltage (V_{REF}).....	18	Theory and Functionality – VOC and OCF.....	25
Reference Voltage Temperature Drift (V_{RE}).....	18	VOC Driven by Non-Inverting Buffered VREF.....	25
Offset Voltage (V_{OE}).....	18	Power Supply Decoupling Capacitor and	
Output Saturation Voltage ($V_{SAT(HIGH/LOW)}$).....	18	Output Capacitive Loads.....	25
Output Voltage Operating Range (V_{OOR}).....	18	Dynamically Change Gain in a System.....	26
Sensitivity (Sens).....	19	Package Outline Drawings.....	27
Sensitivity Error (E_{Sens}).....	19	MC Package.....	27

ABSOLUTE MAXIMUM RATINGS

Characteristic	Symbol	Notes	Rating	Unit
Forward Supply Voltage	V_{CC}		6.5	V
Reverse Supply Voltage	V_{RCC}		-0.5	V
Forward Output Voltage	V_{IOUT}	Applies to V_{IOUT} , V_{OCF} , and V_{REF}	$(V_{CC} + 0.7) \leq 6.5$	V
Reverse Output Voltage	V_{RIOUT}	Applies to V_{IOUT} , V_{OCF} , and V_{REF}	-0.5	V
Forward Input Voltage	V_{OI}	Applies to GAIN_SEL_0, GAIN_SEL_1, and VOC	$(V_{CC} + 0.7) \leq 6.5$	V
Reverse Input Voltage	V_{RI}	Applies to GAIN_SEL_0, GAIN_SEL_1, and VOC	-0.5	V
Operating Ambient Temperature	T_A		-40 to 150	°C
Storage Temperature	T_{stg}		-65 to 165	°C
Maximum Junction Temperature	$T_{J(max)}$		165	°C

ISOLATION CHARACTERISTICS

Characteristic	Symbol	Notes	Rating	Unit
Dielectric Strength Test Voltage	V_{ISO}	Agency type-tested for 60 seconds per UL 60950-1 (edition 2) and 62368-1 (edition 1). Production tested at 3125 V_{RMS} for 1 second in accordance with UL 60950-1 (edition 2) and 62368-1 (edition 1)	5000	V_{RMS}
Working Voltage for Basic Isolation	V_{WVBI}	Maximum approved working voltage for basic (single) isolation according to UL 60950-1 (edition 2) and 62368-1 (edition 1)	1618	V_{PK} or V_{DC}
			1144	V_{RMS}
Working Voltage for Reinforced Isolation	V_{WVRI}	Maximum approved working voltage for reinforced isolation according to UL 60950-1 (edition 2) and 62368-1 (edition 1)	809	V_{PK} or V_{DC}
			572	V_{RMS}
Clearance	D_{cl}	Minimum distance through air from IP leads to signal leads	8.2	mm
Creepage	D_{cr}	Minimum distance along package body from IP leads to signal leads	8.2	mm
Distance Through Insulation	DTI	Minimum internal distance through insulation	70	μm
Comparative Track Index	CTI	Material Group II	400 to 599	V

PINOUT DIAGRAM AND TERMINAL LIST TABLE

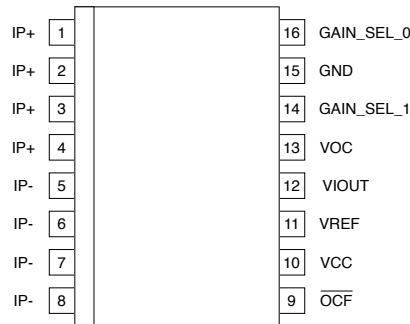

Figure 2: MC Pinout Diagram

Terminal List Table

Number	Name	Description
1, 2, 3, 4	IP+	Terminals for current being sensed; fused internally
5, 6, 7, 8	IP-	Terminals for current being sensed; fused internally
9	$\overline{\text{OCF}}$	Overcurrent fault, open-drain
10	VCC	Device power supply terminal
11	VREF	Zero current voltage reference
12	VIOUT	Analog output representing the current flowing through I_p
13	VOC	Overcurrent fault operation point input
14	GAIN_SEL_1	Gain selection bit 1
15	GND	Device ground terminal
16	GAIN_SEL_0	Gain selection bit 0

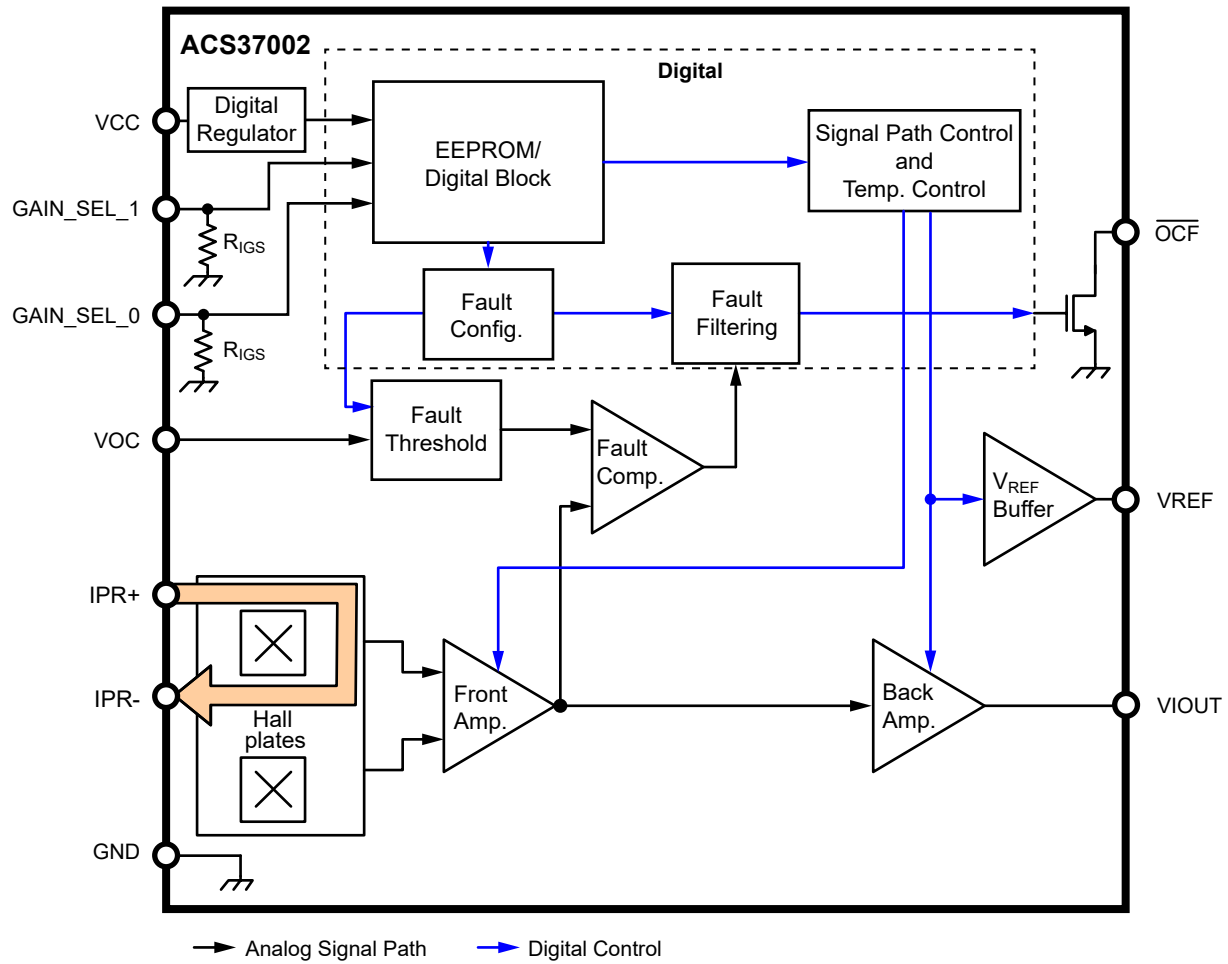

Figure 3: Functional Block Diagram

COMMON ELECTRICAL CHARACTERISTICS: Valid through full operating temperature range, $T_A = -40^\circ\text{C}$ to 150°C , $C_{\text{BYPASS}} = 0.1 \mu\text{F}$, and $V_{\text{CC}} = 5 \text{ V}$ or 3.3 V , unless otherwise specified

Characteristic	Symbol	Test Conditions	Min.	Typ.	Max.	Units
Supply Voltage	V_{CC}	5 V devices only	4.5	5	5.5	V
		3.3 V devices only	3.15	3.3	3.6	V
Supply Current	I_{CC}	No load on VIOUT or VREF; $V_{\text{CC}} = 5 \text{ V}$	–	13	18	mA
		No load on VIOUT or VREF; $V_{\text{CC}} = 3.3 \text{ V}$	–	12	15	mA
Supply Bypass Capacitor	C_{BYPASS}	VCC to GND recommended	0.1	–	–	μF
Output Resistive Load	R_{L}	VIOUT to GND, VIOUT to VCC	10	–	–	k Ω
Output Capacitive Load	C_{L}	VIOUT to GND	–	1	6	nF
Reference Resistive Load	R_{VREF}	VREF to GND (recommended to supply VOC); VREF to VCC	10	62.7	–	k Ω
Reference Capacitive Load	C_{VREF}	VREF to GND	–	–	6	nF
Fault Pull-Up Resistance	R_{PU}		4.7	–	500	k Ω
VOC Resistive Load	R_{VOC}	VOC to GND	10	12.7	–	k Ω
VOC Capacitive Load	C_{VOC}	VOC to GND	–	–	1	nF
Primary Conductor Resistance	R_{IP}	$T_A = 25^\circ\text{C}$	–	0.27	–	m Ω
Primary Conductor Inductance	L_{IP}		–	4.45	–	nH
Power-On Reset Voltage	$V_{\text{POR(H)}}$	V_{CC} rising [1]	2.6	2.9	3.1	V
	$V_{\text{POR(L)}}$	V_{CC} falling [1]	2.2	2.5	2.8	V
POR Hysteresis	$V_{\text{POR(HYS)}}$		250	–	–	mV
Power-On Time	t_{POD}	Time from V_{CC} rising $\geq V_{\text{POR(H)}}$ after a POR event until power-on; VREF, OCF, VIOUT	100	–	–	μs
Overvoltage Detection (OVD) Threshold	$V_{\text{OVD(H)}}$	V_{CC} rising [1]	6.1	6.4	6.8	V
	$V_{\text{OVD(L)}}$	V_{CC} falling [1]	5.6	5.8	6.1	V
Overvoltage Detection Hysteresis	$V_{\text{OVD(HYS)}}$		–	660	–	mV
OVD Delay Time	$t_{\text{dOVD(E)}}$	Time from V_{CC} rising $\geq V_{\text{OVD(EN)}}$ until OVD asserts	60	82	120	μs
	$t_{\text{dOVD(D)}}$	Time from V_{CC} falling $\leq V_{\text{OVD(DIS)}}$ until OVD clears	–	7	–	μs

Continued on the next page...

COMMON PERFORMANCE CHARACTERISTICS (V_{IOUT}): Valid through full operating temperature range, $T_A = -40^\circ\text{C}$ to 150°C , $C_{\text{BYPASS}} = 0.1 \mu\text{F}$, and $V_{\text{CC}} = 5 \text{ V}$ or 3.3 V , unless otherwise specified

Characteristic	Symbol	Test Conditions	Min.	Typ.	Max.	Units
OUTPUT SIGNAL CHARACTERISTICS (V_{IOUT})						
Saturation Voltage	V _{SAT(H)}	R _L = 10 kΩ to GND	V _{CC} - 0.25	–	–	V
	V _{SAT(L)}	R _L = 10 kΩ to V _{CC}	–	–	0.15	V
Output Operating Range	V _{OOR}	5 V linear operating range	0.5	–	4.5	V
		3.3 V linear operating range	0.3	–	3.0	V
Output Current Limit	I _{OUT(src)}	V _{IOUT} shorted to GND	–	25	–	mA
	I _{OUT(snk)}	V _{IOUT} shorted to V _{CC}	–	25	–	mA
Internal Bandwidth	BW	Small signal –3 dB, C _L = 5.7 nF	–	400	–	kHz
Rise Time	t _r	T _A = 25°C, C _L = 5.7 nF, 10%-90% of 1 V output swing	–	0.7	2.5	μs
Response Time	t _{RESPONSE}	T _A = 25°C, C _L = 5.7 nF, 90% input to 90% of 1 V output swing	–	1.1	2.5	μs
Propagation Delay	t _{PD}	T _A = 25°C, C _L = 5.7 nF, 20% input to 20% of 1 V output swing	–	0.7	2	μs
Noise Density	I _{ND}	Input-referenced noise density; T _A = 25°C, C _L = 5.7 nF; V _{CC} = 5 V	–	350	–	μA/√Hz
		Input-referenced noise density; T _A = 25°C, C _L = 5.7 nF; V _{CC} = 3.3 V	–	450	–	μA/√Hz
Noise	I _N	Input-referenced noise at 400 kHz; T _A = 25°C, C _L = 5.7 nF; V _{CC} = 5 V	–	277	–	mA _{RMS}
		Input-referenced noise at 400 kHz; T _A = 25°C, C _L = 5.7 nF; V _{CC} = 3.3 V	–	357	–	mA _{RMS}
Nonlinearity	E _{LIN}		–	±0.75	–	%
Power Supply Offset Error	V _{OE(PS)}	V _{CC} @ V _{CC(MIN)} or V _{CC(MAX)}	–10	±1	10	mV
Power Supply Sensitivity Error	E _{SENS(PS)}	V _{CC} @ V _{CC(MIN)} or V _{CC(MAX)}	–1.5	±0.3	1.5	%
Power Supply Rejection Ratio Offset	PSRR _O	DC to 1 kHz, 100 mV pk-pk ripple around V _{CC} = 5 V, I _P = 0 A, change in V _{OE}	–	–40	–	dB
		1 to 100 kHz, 100 mV pk-pk ripple around V _{CC} = 5 V, I _P = 0 A, change in V _{OE}	–	–30	–	dB
Power Supply Rejection Ratio Sens	PSRR _S	DC to 1 kHz, 100 mV pk-pk ripple around V _{CC} = 5 V, I _P = I _{PR(MAX)} , change in Sens	–	–15	–	dB
		1 to 100 kHz, 100 mV pk-pk ripple around V _{CC} = 5 V, I _P = I _{PR(MAX)} , change in Sens	–	–6	–	dB
Common-Mode Field Rejection	CMFR	Input-referred error due to common-mode field	–	4	–	mA/G

Continued on the next page...

COMMON PERFORMANCE CHARACTERISTICS (VREF, FAULT, GAIN_SEL): Valid through full operating temperature range, $T_A = -40^{\circ}\text{C}$ to 150°C , $C_{\text{BYPASS}} = 0.1 \mu\text{F}$, and $V_{\text{CC}} = 5 \text{ V}$ or 3.3 V , unless otherwise specified

Characteristic	Symbol	Test Conditions	Min.	Typ.	Max.	Units
REFERENCE OUTPUT CHARACTERISTICS (VREF)						
Zero Current Reference Voltage	V_{REF}	Bidirectional; $V_{\text{CC}} = 5 \text{ V}$	2.49	2.5	2.51	V
		Bidirectional; $V_{\text{CC}} = 3.3 \text{ V}$	1.64	1.65	1.66	V
		Unidirectional; $V_{\text{CC}} = 5 \text{ V}$	0.49	0.5	0.51	V
Reference Source Current Limit	$I_{\text{REF}(\text{src})}$	Maximum current V_{REF} can passively source	–	25	–	mA
	$I_{\text{REF}(\text{snk})}$	Maximum current V_{REF} can passively sink	–	25	–	mA
OVERCURRENT FAULT CHARACTERISTICS (OCF)						
OCF On Voltage	$V_{\text{FAULT-ON}}$	$R_{\text{PU}} = 4.7 \text{ k}\Omega$, Fault Asserted	–	0.07	0.4	V
OCF Sink Current [3]	$I_{\text{OCF}(\text{snk})}$	No Fault	–	100	–	nA
		Fault Asserted	0.01	–	1.1	mA
VOC Operating Voltage Range	V_{VOC}	$V_{\text{CC}} = 5 \text{ V}$	0.5	–	2	V
		$V_{\text{CC}} = 3.3 \text{ V}$	0.33	–	1.32	V
Fault Error	E_{OCF}		–10	± 3	10	% $I_{\text{OCF-OP}}$
OCF Hysteresis	$I_{\text{OCF}(\text{HYS})}$	$V_{\text{CC}} = 5 \text{ V}$	–	6	–	%FS
		$V_{\text{CC}} = 3.3 \text{ V}$	–	9	–	%FS
OCF Response Time [3]	t_{OCF}	Time from $I_{\text{OCF-OP}}$ with a $1.2 \times I_{\text{OCF-OP}}$ until fault asserts	–	1	1.5	μs
OCF Reaction Time [3]	$t_{\text{OCF-R}}$	Time from $I_{\text{OCF-OP}} - I_{\text{OCF}(\text{HYS})}$ until fault releases	–	0.75	1	μs
OCF Mask [3]	$t_{\text{OCF-MASK}}$	Time $I_{\text{OCF-OP}}$ must be present after $t_{\text{OCF-R}}$ for fault assertion	0	0 [2]	3	μs
OCF Hold Time [3]	$t_{\text{OCF-HOLD}}$	Minimum duration of FAULT assertion	0	0 [2]	5	ms
GAIN SELECTION PIN CHARACTERISTICS (GAIN_SEL_0, GAIN_SEL_1)						
Gain Select Internal Resistor	R_{GSint}		–	1	–	$\text{M}\Omega$
GAIN_SEL Logic Input Voltage	$V_{\text{H}(\text{SEL})}$	$V_{\text{CC}} = 5 \text{ V}$	3.75	–	–	V
		$V_{\text{CC}} = 3.3 \text{ V}$	2.5	–	–	V
	$V_{\text{L}(\text{SEL})}$	$V_{\text{CC}} = 5 \text{ V}$	–	–	0.5	V
		$V_{\text{CC}} = 3.3 \text{ V}$	–	–	0.4	V
Leakage Current [3]	$I_{\text{SEL}(\text{snk})}$		–	–	10	μA

[1] V_{CC} rate +1 V/ms, for best accuracy.

[2] Typical value is factory default.

[3] Guaranteed by design and bench validated.

ACS37002LMCATR-050B5

ACS37002LMCATR-050B5 Gain_Sel Pin Performance Key

				Selection Identifier
Parameter (Units)	Gain_Sel_1 (Boolean)	Gain_Sel_0 (Boolean)	Sens (mV/A)	Max I _P (A)
Type	Digital Input	Digital Input	Calculation	Bidirectional
Selection Combination	0	0	40	50
	0	1	50	40
	1	0	60	33.3
	1	1	30	66.7

ACS37002LMCATR-050B5 PERFORMANCE CHARACTERISTICS: Valid through full operating temperature range, T_A = -40°C to 150°C, C_{BYPASS} = 0.1 μF, and V_{CC} = 5 V, unless otherwise specified

Characteristic	Symbol	Test Conditions	Min.	Typ. [1]	Max.	Units
NOMINAL PERFORMANCE						
Current Sensing Range	I _{PR}	Gain Sel 00	-50	-	50	A
		Gain Sel 01	-40	-	40	A
		Gain Sel 10	-33.3	-	33.3	A
		Gain Sel 11	-66.7	-	66.7	A
Sensitivity	Sens	Gain Sel 00; I _{PR(min)} < I _P < I _{PR(max)}	-	40	-	mV/A
		Gain Sel 01; I _{PR(min)} < I _P < I _{PR(max)}	-	50	-	mV/A
		Gain Sel 10; I _{PR(min)} < I _P < I _{PR(max)}	-	60	-	mV/A
		Gain Sel 11; I _{PR(min)} < I _P < I _{PR(max)}	-	30	-	mV/A
Overcurrent Fault Operating Range	I _{OCF-OR}	Typ. = factory-programmed default, FS = Full-Scale	50	100	200	%FS
Zero Current Output Voltage	V _{IOUT(Q)}	Bidirectional; I _P = 0 A, T _A = 25°C	-	2.5	-	V
TOTAL ERROR (V_{IOUT(ACTUAL)} - (Sens_(IDEAL) × I_{PR} + V_{REF})) / (Sens_(IDEAL) × I_{PR}) × 100 AND TOTAL ERROR COMPONENTS						
Total Error	E _{TOT}	I _P = I _{PR(max)}	-1.75	±1.2	1.75	%
Sensitivity Error	E _{SENS}	I _P = I _{PR(max)}	-1.5	±1.1	1.5	%
Zero Current Reference Error	V _{RE}	V _{REFactual} - V _{REFideal} , I _P = 0 A, T _A = 25°C to 150°C	-10	-1 ±3	10	mV
		V _{REFactual} - V _{REFideal} , I _P = 0 A, T _A = -40°C to 25°C	-10	-1 ±4	10	mV
Offset Error	V _{OE}	V _{IOUT(Q)} - V _{REF} , I _P = 0 A, T _A = 25°C to 150°C	-8	-1 ±3	8	mV
		V _{IOUT(Q)} - V _{REF} , I _P = 0 A, T _A = -40°C to 25°C	-8	-1 ±4	8	mV
QVO Error	V _{QE}	V _{IOUT(Q)} , I _P = 0 A, T _A = 25°C to 150°C	-10	-2 ±4	10	mV
		V _{IOUT(Q)} , I _P = 0 A, T _A = -40°C to 25°C	-10	-2 ±6	10	mV
TOTAL ERROR AND TOTAL ERROR COMPONENTS INCLUDING LIFETIME DRIFT [2][3]						
Total Error Including Lifetime Drift	E _{TOT_LTD}	I _P = I _{PR(max)}	-4.2	-0.8 ±2.4	4.2	%
Sensitivity Error Including Lifetime Drift	E _{SENS_LTD}	I _P = I _{PR(max)}	-4	-1.3 ±1.7	4	%
Zero Current Reference Error Including Lifetime Drift	V _{RE_LTD}	V _{REFactual} - V _{REFideal} , I _P = 0 A, T _A = 25°C to 150°C	-10	-1 ±4	10	mV
		V _{REFactual} - V _{REFideal} , I _P = 0 A, T _A = -40°C to 25°C	-10	-1 ±5	10	mV
Offset Error Including Lifetime Drift	V _{OE_LTD}	V _{IOUT(Q)} - V _{REF} , I _P = 0 A, T _A = 25°C to 150°C	-10	-1 ±6	10	mV
		V _{IOUT(Q)} - V _{REF} , I _P = 0 A, T _A = -40°C to 25°C	-12	-1 ±6	12	mV
QVO Error Including Lifetime Drift	V _{QE_LTD}	V _{IOUT(Q)} , I _P = 0 A, T _A = 25°C to 150°C	-12	-2 ±5	12	mV
		V _{IOUT(Q)} , I _P = 0 A, T _A = -40°C to 25°C	-12	-2 ±6	12	mV

[1] Typical values are the mean ±3 sigma of production distributions. These are formatted as mean ±3 sigma.

[2] Typical values are the mean ±3 sigma statistical combination of production and AEC-Q100 individual drift distributions. These are formatted as mean ±3 sigma.

[3] Lifetime drift characteristics are based on a statistical combination of production distributions and worst-case distribution of parametric drift of individuals observed during AEC-Q100 qualification. Contact Allegro MicroSystems for further information.

ACS37002LMCATR-066B5

ACS37002LMCATR-066B5 Gain_Sel Pin Performance Key

				Selection Identifier	
Parameter (Units)	Gain_Sel_1 (Boolean)	Gain_Sel_0 (Boolean)	Sens (mV/A)	Max I _P (A)	
Type	Digital Input	Digital Input	Calculation	Bidirectional	
Selection Combination	0	0	30	66.7	
	0	1	25	80	
	1	0	20	100	
	1	1	15	133.3	

ACS37002LMABTR-066B5 PERFORMANCE CHARACTERISTICS: Valid through full operating temperature range, T_A = -40°C to 150°C, C_{BYPASS} = 0.1 μF, and V_{CC} = 5 V, unless otherwise specified

Characteristic	Symbol	Test Conditions	Min.	Typ. [1]	Max.	Units
NOMINAL PERFORMANCE						
Current Sensing Range	I _{PR}	Gain Sel 00	-66.7	-	66.7	A
		Gain Sel 01	-80	-	80	A
		Gain Sel 10	-100	-	100	A
		Gain Sel 11	-133.3	-	133.3	A
Sensitivity	Sens	Gain Sel 00; I _{PR(min)} < I _P < I _{PR(max)}	-	30	-	mV/A
		Gain Sel 01; I _{PR(min)} < I _P < I _{PR(max)}	-	25	-	mV/A
		Gain Sel 10; I _{PR(min)} < I _P < I _{PR(max)}	-	20	-	mV/A
		Gain Sel 11; I _{PR(min)} < I _P < I _{PR(max)}	-	15	-	mV/A
Overcurrent Fault Operating Range	I _{OCF-OR}	Typ. = factory-programmed default, FS = Full-Scale	50	100	200	%FS
Zero Current Output Voltage	V _{IOUT(Q)}	Bidirectional; I _P = 0 A, T _A = 25°C	-	2.5	-	V
TOTAL ERROR (V_{IOUT(ACTUAL)} - (Sens_(IDEAL) × I_{PR} + V_{REF})) / (Sens_(IDEAL) × I_{PR}) × 100 AND TOTAL ERROR COMPONENTS						
Total Error	E _{TOT}	I _P = I _{PR(max)}	-1.75	±1.2	1.75	%
Sensitivity Error	E _{SENS}	I _P = I _{PR(max)}	-1.5	±1.1	1.5	%
Zero Current Reference Error	V _{RE}	V _{REFactual} - V _{REFideal} , I _P = 0 A, T _A = 25°C to 150°C	-10	-1 ±3	10	mV
		V _{REFactual} - V _{REFideal} , I _P = 0 A, T _A = -40°C to 25°C	-10	-1 ±4	10	mV
Offset Error	V _{OE}	V _{IOUT(Q)} - V _{REF} , I _P = 0 A, T _A = 25°C to 150°C	-8	-1 ±3	8	mV
		V _{IOUT(Q)} - V _{REF} , I _P = 0 A, T _A = -40°C to 25°C	-8	-1 ±4	8	mV
QVO Error	V _{QE}	V _{IOUT(Q)} , I _P = 0 A, T _A = 25°C to 150°C	-10	-2 ±4	10	mV
		V _{IOUT(Q)} , I _P = 0 A, T _A = -40°C to 25°C	-10	-2 ±6	10	mV
TOTAL ERROR AND TOTAL ERROR COMPONENTS INCLUDING LIFETIME DRIFT [2,3]						
Total Error Including Lifetime Drift	E _{TOT_LTD}	I _P = I _{PR(max)}	-4.2	-0.8 ±2.4	4.2	%
Sensitivity Error Including Lifetime Drift	E _{SENS_LTD}	I _P = I _{PR(max)}	-4	-1.3 ±1.7	4	%
Zero Current Reference Error Including Lifetime Drift	V _{RE_LTD}	V _{REFactual} - V _{REFideal} , I _P = 0 A, T _A = 25°C to 150°C	-10	-1 ±4	10	mV
		V _{REFactual} - V _{REFideal} , I _P = 0 A, T _A = -40°C to 25°C	-10	-1 ±5	10	mV
Offset Error Including Lifetime Drift	V _{OE_LTD}	V _{IOUT(Q)} - V _{REF} , I _P = 0 A, T _A = 25°C to 150°C	-10	-1 ±6	10	mV
		V _{IOUT(Q)} - V _{REF} , I _P = 0 A, T _A = -40°C to 25°C	-12	-1 ±6	12	mV
QVO Error Including Lifetime Drift	V _{QE_LTD}	V _{IOUT(Q)} , I _P = 0 A, T _A = 25°C to 150°C	-12	-2 ±5	12	mV
		V _{IOUT(Q)} , I _P = 0 A, T _A = -40°C to 25°C	-12	-2 ±6	12	mV

[1] Typical values are the mean ±3 sigma of production distributions. These are formatted as mean ±3 sigma.

[2] Typical values are the mean ±3 sigma statistical combination of production and AEC-Q100 individual drift distributions. These are formatted as mean ±3 sigma.

[3] Lifetime drift characteristics are based on a statistical combination of production distributions and worst-case distribution of parametric drift of individuals observed during AEC-Q100 qualification. Contact Allegro MicroSystems for further information.

ACS37002LMCATR-090B5

ACS37002LMCATR-090B5 Gain_Sel Pin Performance Key

				Selection Identifier
Parameter (Units)	Gain_Sel_1 (Boolean)	Gain_Sel_0 (Boolean)	Sens (mV/A)	Max I _P (A)
Type	Digital Input	Digital Input	Calculation	Bidirectional
Selection Combination	0	0	22.2	90
	0	1	18.5	108
	1	0	14.8	135
	1	1	11.1	180

ACS37002LMCATR-090B5 PERFORMANCE CHARACTERISTICS: Valid through full operating temperature range, T_A = -40°C to 150°C, C_{BYPASS} = 0.1 μF, and V_{CC} = 5 V, unless otherwise specified

Characteristic	Symbol	Test Conditions	Min.	Typ. [1]	Max.	Units
NOMINAL PERFORMANCE						
Current Sensing Range	I _{PR}	Gain Sel 00	-90	-	90	A
		Gain Sel 01	-108	-	108	A
		Gain Sel 10	-135	-	135	A
		Gain Sel 11	-180	-	180	A
Sensitivity	Sens	Gain Sel 00; I _{PR(min)} < I _P < I _{PR(max)}	-	22.2	-	mV/A
		Gain Sel 01; I _{PR(min)} < I _P < I _{PR(max)}	-	18.5	-	mV/A
		Gain Sel 10; I _{PR(min)} < I _P < I _{PR(max)}	-	14.8	-	mV/A
		Gain Sel 11; I _{PR(min)} < I _P < I _{PR(max)}	-	11.1	-	mV/A
Overcurrent Fault Operating Range	I _{OCF-OR}	Typ. = factory-programmed default, FS = Full-Scale	50	100	200	%FS
Zero Current Output Voltage	V _{IOUT(Q)}	Bidirectional; I _P = 0 A, T _A = 25°C	-	2.5	-	V
TOTAL ERROR (V_{IOUT(ACTUAL)} - (Sens_(IDEAL) × I_{PR} + V_{REF})) / (Sens_(IDEAL) × I_{PR}) × 100 AND TOTAL ERROR COMPONENTS						
Total Error	E _{TOT}	I _P = I _{PR(max)}	-1.75	±1.2	1.75	%
Sensitivity Error	E _{SENS}	I _P = I _{PR(max)}	-1.5	±1.1	1.5	%
Zero Current Reference Error	V _{RE}	V _{REFactual} - V _{REFideal} , I _P = 0 A, T _A = 25°C to 150°C	-10	-1 ±3	10	mV
		V _{REFactual} - V _{REFideal} , I _P = 0 A, T _A = -40°C to 25°C	-10	-1 ±4	10	mV
Offset Error	V _{OE}	V _{IOUT(Q)} - V _{REF} , I _P = 0 A, T _A = 25°C to 150°C	-8	-1 ±3	8	mV
		V _{IOUT(Q)} - V _{REF} , I _P = 0 A, T _A = -40°C to 25°C	-8	-1 ±4	8	mV
QVO Error	V _{QE}	V _{IOUT(Q)} , I _P = 0 A, T _A = 25°C to 150°C	-10	-2 ±4	10	mV
		V _{IOUT(Q)} , I _P = 0 A, T _A = -40°C to 25°C	-10	-2 ±6	10	mV
TOTAL ERROR AND TOTAL ERROR COMPONENTS INCLUDING LIFETIME DRIFT [2,3]						
Total Error Including Lifetime Drift	E _{TOT_LTD}	I _P = I _{PR(max)}	-4.2	-0.8 ±2.4	4.2	%
Sensitivity Error Including Lifetime Drift	E _{SENS_LTD}	I _P = I _{PR(max)}	-4	-1.3 ±1.7	4	%
Zero Current Reference Error Including Lifetime Drift	V _{RE_LTD}	V _{REFactual} - V _{REFideal} , I _P = 0 A, T _A = 25°C to 150°C	-10	-1 ±4	10	mV
		V _{REFactual} - V _{REFideal} , I _P = 0 A, T _A = -40°C to 25°C	-10	-1 ±5	10	mV
Offset Error Including Lifetime Drift	V _{OE_LTD}	V _{IOUT(Q)} - V _{REF} , I _P = 0 A, T _A = 25°C to 150°C	-10	-1 ±6	10	mV
		V _{IOUT(Q)} - V _{REF} , I _P = 0 A, T _A = -40°C to 25°C	-12	-1 ±6	12	mV
QVO Error Including Lifetime Drift	V _{QE_LTD}	V _{IOUT(Q)} , I _P = 0 A, T _A = 25°C to 150°C	-12	-2 ±5	12	mV
		V _{IOUT(Q)} , I _P = 0 A, T _A = -40°C to 25°C	-12	-2 ±6	12	mV

[1] Typical values are the mean ±3 sigma of production distributions. These are formatted as mean ±3 sigma.

[2] Typical values are the mean ±3 sigma statistical combination of production and AEC-Q100 individual drift distributions. These are formatted as mean ±3 sigma.

[3] Lifetime drift characteristics are based on a statistical combination of production distributions and worst-case distribution of parametric drift of individuals observed during AEC-Q100 qualification. Contact Allegro MicroSystems for further information.

ACS37002LMCATR-050U5

ACS37002LMCATR-050U5 Gain_Sel Pin Performance Key

				Selection Identifier
Parameter (Units)	Gain_Sel_1 (Boolean)	Gain_Sel_0 (Boolean)	Sens (mV/A)	Max I _P (A)
Type	Digital Input	Digital Input	Calculation	Unidirectional
Selection Combination	0	0	80	50
	0	1	100	40
	1	0	120	33.3
	1	1	60	66.7

ACS37002LMCATR-050U5 PERFORMANCE CHARACTERISTICS: Valid through full operating temperature range, T_A = -40°C to 150°C, C_{BYPASS} = 0.1 μF, and V_{CC} = 5 V, unless otherwise specified

Characteristic	Symbol	Test Conditions	Min.	Typ. [1]	Max.	Units
NOMINAL PERFORMANCE						
Current Sensing Range	I _{PR}	Gain Sel 00	0	–	50	A
		Gain Sel 01	0	–	40	A
		Gain Sel 10	0	–	33.3	A
		Gain Sel 11	0	–	66.7	A
Sensitivity	Sens	Gain Sel 00; I _{PR(min)} < I _P < I _{PR(max)}	–	80	–	mV/A
		Gain Sel 01; I _{PR(min)} < I _P < I _{PR(max)}	–	100	–	mV/A
		Gain Sel 10; I _{PR(min)} < I _P < I _{PR(max)}	–	120	–	mV/A
		Gain Sel 11; I _{PR(min)} < I _P < I _{PR(max)}	–	60	–	mV/A
Overcurrent Fault Operating Range	I _{OCF-OR}	Typ. = factory-programmed default, FS = Full-Scale	25	50	100	%FS
Zero Current Output Voltage	V _{IOUT(Q)}	Unidirectional; I _P = 0 A, T _A = 25°C	–	0.5	–	V
TOTAL ERROR (V_{IOUT(ACTUAL)} – (Sens_(IDEAL) × I_{PR} + V_{REF})) / (Sens_(IDEAL) × I_{PR}) × 100 AND TOTAL ERROR COMPONENTS						
Total Error	E _{TOT}	I _P = I _{PR(max)}	–1.75	±1.2	1.75	%
Sensitivity Error	E _{SENS}	I _P = I _{PR(max)} ; T _A = 25°C to 150°C or –40°C to 25°C	–1.5	±1.1	1.5	%
Zero Current Reference Error	V _{RE}	V _{REFactual} – V _{REFideal} ; I _P = 0 A, T _A = 25°C to 150°C	–10	–1 ±3	10	mV
		V _{REFactual} – V _{REFideal} ; I _P = 0 A, T _A = –40°C to 25°C	–10	–1 ±4	10	mV
Offset Error	V _{OE}	V _{IOUT(Q)} – V _{REF} ; I _P = 0 A, T _A = 25°C to 150°C	–8	–1 ±3	8	mV
		V _{IOUT(Q)} – V _{REF} ; I _P = 0 A, T _A = –40°C to 25°C	–8	–1 ±4	8	mV
QVO Error	V _{QE}	V _{IOUT(Q)} ; I _P = 0 A, T _A = 25°C to 150°C	–10	–2 ±4	10	mV
		V _{IOUT(Q)} ; I _P = 0 A, T _A = –40°C to 25°C	–10	–2 ±6	10	mV
TOTAL ERROR AND TOTAL ERROR COMPONENTS INCLUDING LIFETIME DRIFT [2,3]						
Total Error Including Lifetime Drift	E _{TOT_LTD}	I _P = I _{PR(max)}	–4.2	–0.8 ±2.4	4.2	%
Sensitivity Error Including Lifetime Drift	E _{SENS_LTD}	I _P = I _{PR(max)}	–4	–1.3 ±1.7	4	%
Zero Current Reference Error Including Lifetime Drift	V _{RE_LTD}	V _{REFactual} – V _{REFideal} ; I _P = 0 A, T _A = 25°C to 150°C	–10	–1 ±4	10	mV
		V _{REFactual} – V _{REFideal} ; I _P = 0 A, T _A = –40°C to 25°C	–10	–1 ±5	10	mV
Offset Error Including Lifetime Drift	V _{OE_LTD}	V _{IOUT(Q)} – V _{REF} ; I _P = 0 A, T _A = 25°C to 150°C	–10	–1 ±6	10	mV
		V _{IOUT(Q)} – V _{REF} ; I _P = 0 A, T _A = –40°C to 25°C	–12	–1 ±6	12	mV
QVO Error Including Lifetime Drift	V _{QE_LTD}	V _{IOUT(Q)} ; I _P = 0 A, T _A = 25°C to 150°C	–12	–2 ±5	12	mV
		V _{IOUT(Q)} ; I _P = 0 A, T _A = –40°C to 25°C	–12	–2 ±6	12	mV

[1] Typical values are the mean ±3 sigma of production distributions. These are formatted as mean ±3 sigma.

[2] Typical values are the mean ±3 sigma statistical combination of production and AEC-Q100 individual drift distributions. These are formatted as mean ±3 sigma.

[3] Lifetime drift characteristics are based on a statistical combination of production distributions and worst-case distribution of parametric drift of individuals observed during AEC-Q100 qualification. Contact Allegro MicroSystems for further information.

ACS37002LMCATR-050B3

ACS37002LMCATR-050B3 Gain_Sel Pin Performance Key

				Selection Identifier
Parameter (Units)	Gain_Sel_1 (Boolean)	Gain_Sel_0 (Boolean)	Sens (mV/A)	Max I _P (A)
Type	Digital Input	Digital Input	Calculation	Bidirectional
Selection Combination	0	0	26.4	50
	0	1	33	40
	1	0	39.6	33.3
	1	1	19.8	66.7

ACS37002LMABTR-050B3 PERFORMANCE CHARACTERISTICS: Valid through full operating temperature range, T_A = -40°C to 150°C, C_{BYPASS} = 0.1 μF, and V_{CC} = 3.3 V, unless otherwise specified

Characteristic	Symbol	Test Conditions	Min.	Typ. [1]	Max.	Units
NOMINAL PERFORMANCE						
Current Sensing Range	I _{PR}	Gain Sel 00	-50	-	50	A
		Gain Sel 01	-40	-	40	A
		Gain Sel 10	-33.3	-	33.3	A
		Gain Sel 11	-66.7	-	66.7	A
Sensitivity	Sens	Gain Sel 00; I _{PR(min)} < I _P < I _{PR(max)}	-	26.4	-	mV/A
		Gain Sel 01; I _{PR(min)} < I _P < I _{PR(max)}	-	33	-	mV/A
		Gain Sel 10; I _{PR(min)} < I _P < I _{PR(max)}	-	39.6	-	mV/A
		Gain Sel 11; I _{PR(min)} < I _P < I _{PR(max)}	-	19.8	-	mV/A
Overcurrent Fault Operating Range	I _{OCF-OR}	Typ. = factory-programmed default, FS = Full-Scale	50	100	200	%FS
Zero Current Output Voltage	V _{IOUT(Q)}	Bidirectional; I _P = 0 A, T _A = 25°C	-	1.65	-	V
TOTAL ERROR (V_{IOUT(ACTUAL)} - (Sens_(IDEAL) × I_{PR} + V_{REF})) / (Sens_(IDEAL) × I_{PR}) × 100 AND TOTAL ERROR COMPONENTS						
Total Error	E _{TOT}	I _P = I _{PR(max)}	-1.75	±1.2	1.75	%
Sensitivity Error	E _{SENS}	I _P = I _{PR(max)}	-1.5	±1.1	1.5	%
Zero Current Reference Error	V _{RE}	V _{REFactual} - V _{REFideal} , I _P = 0 A, T _A = 25°C to 150°C	-10	-1 ±3	10	mV
		V _{REFactual} - V _{REFideal} , I _P = 0 A, T _A = -40°C to 25°C	-10	-1 ±4	10	mV
Offset Error	V _{OE}	V _{IOUT(Q)} - V _{REF} , I _P = 0 A, T _A = 25°C to 150°C	-10	-1 ±3	10	mV
		V _{IOUT(Q)} - V _{REF} , I _P = 0 A, T _A = -40°C to 25°C	-10	-1 ±4	10	mV
QVO Error	V _{QE}	V _{IOUT(Q)} , I _P = 0 A, T _A = 25°C to 150°C	-10	-2 ±4	10	mV
		V _{IOUT(Q)} , I _P = 0 A, T _A = -40°C to 25°C	-10	-2 ±6	10	mV
TOTAL ERROR AND TOTAL ERROR COMPONENTS INCLUDING LIFETIME DRIFT [2,3]						
Total Error Including Lifetime Drift	E _{TOT_LTD}	I _P = I _{PR(max)}	-4.2	-0.8 ±2.4	4.2	%
Sensitivity Error Including Lifetime Drift	E _{SENS_LTD}	I _P = I _{PR(max)}	-4	-1.3 ±1.7	4	%
Zero Current Reference Error Including Lifetime Drift	V _{RE_LTD}	V _{REFactual} - V _{REFideal} , I _P = 0 A, T _A = 25°C to 150°C	-10	-1 ±4	10	mV
		V _{REFactual} - V _{REFideal} , I _P = 0 A, T _A = -40°C to 25°C	-10	-1 ±5	10	mV
Offset Error Including Lifetime Drift	V _{OE_LTD}	V _{IOUT(Q)} - V _{REF} , I _P = 0 A, T _A = 25°C to 150°C	-10	-1 ±6	10	mV
		V _{IOUT(Q)} - V _{REF} , I _P = 0 A, T _A = -40°C to 25°C	-12	-1 ±6	12	mV
QVO Error Including Lifetime Drift	V _{QE_LTD}	V _{IOUT(Q)} , I _P = 0 A, T _A = 25°C to 150°C	-12	-2 ±5	12	mV
		V _{IOUT(Q)} , I _P = 0 A, T _A = -40°C to 25°C	-12	-2 ±6	12	mV

[1] Typical values are the mean ±3 sigma of production distributions. These are formatted as mean ±3 sigma.

[2] Typical values are the mean ±3 sigma statistical combination of production and AEC-Q100 individual drift distributions. These are formatted as mean ±3 sigma.

[3] Lifetime drift characteristics are based on a statistical combination of production distributions and worst-case distribution of parametric drift of individuals observed during AEC-Q100 qualification. Contact Allegro MicroSystems for further information.

FUNCTIONAL DESCRIPTION

Power-On Reset Operation

The descriptions in this section use the listed test conditions and assume a temperature of 25°C. The provided graphs in this section show V_{IOUT} moving with V_{CC} . The voltage of V_{IOUT} during a high-impedance state will be most consistent with a known load (R_L , C_L).

POWER-ON

As V_{CC} ramps up, V_{IOUT} and V_{REF} pins are high impedance until V_{CC} reaches and passes $V_{POR(H)}$.

POWER-OFF

As V_{CC} drops below $V_{POR(L)}$, the outputs will enter a high-impedance state.

Note: Since the device is entering a high-impedance state, and not driving the output, the time it takes the output to reach a steady state will depend on the external circuitry used.

POWER-ON RESET (POR)

If V_{CC} falls below $V_{POR(L)}$ while in operation, the device will enter a POR event and reset, V_{IOUT} and V_{REF} will switch to high-impedance state.

POWER-ON DELAY (T_{POD})

When the supply is ramped to $V_{POR(H)}$, the device will require a finite time to power its internal components before the outputs are released from high impedance and can respond to an input magnetic field [A]. Power-On Time, t_{POD} , is defined as the time it takes for the output voltage to settle within $\pm 10\%$ of its steady-state value under an applied magnetic field. After this delay, the output will quickly approach $V_{IOUT(IP)} = \text{Sens} \times I_P + V_{REF}$.

Overvoltage Detection (OVD)

To ensure that the device's output is reporting accurately, the device contains an overvoltage detection flag. This flag on V_{IOUT} can be used to alert the system when the supply voltage for the device is outside of the operational range.

OVERVOLTAGE DETECTION VOLTAGE THRESHOLDS ($V_{OVD(H/L)}$)

When V_{CC} raises above $V_{OVD(H)}$, the V_{IOUT} pin output will go high impedance and V_{IOUT} will be pulled to either V_{CC} or GND , depending if R_L is in a pull-up or pull-down configuration.

OVERVOLTAGE DETECTION HYSTERESIS ($V_{OVD(HYS)}$)

There is hysteresis between enable and disable thresholds to reduce nuisance flagging and clears.

OVERVOLTAGE ENABLE AND DISABLE TIME ($T_{OVD(E/D)}$)

The enable time for OVD, $t_{OVD(E)}$, is the time from $V_{OVD(H)}$ to OVD flag [B]. The OVD enable flag has a counter to reduce transients faster than 64 μs from triggering nuisance flags.

The disable time for OVD, $t_{OVD(D)}$, is the time from $V_{OVD(L)}$ to the OVD clear to normal operation [C]. The disable time for OVD does not have a counter to release the output and resume reporting.

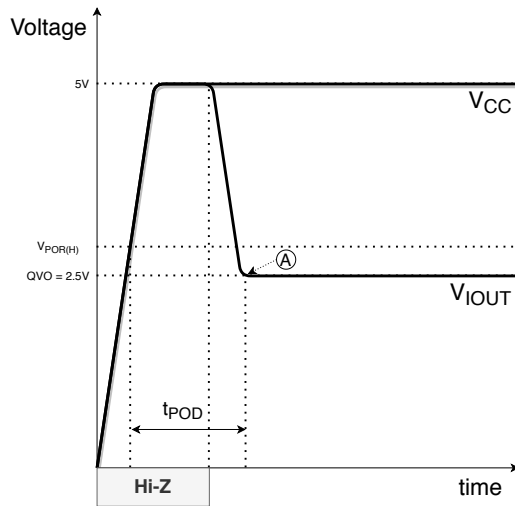

Figure 4: t_{POD} behavior with $R_L = Pull-Up$

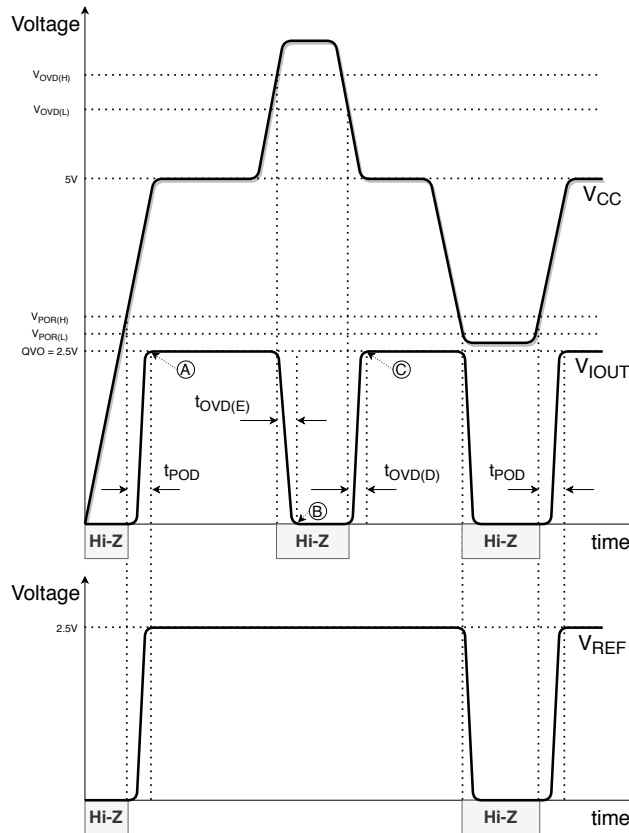

Figure 5: t_{POD} and $t_{OVD(E/D)}$ with $R_L = Pull-Down$

Absolute Maximum Ratings

These are the maximum application or environmental conditions that the device can be subjected before damage may occur.

FORWARD AND REVERSE SUPPLY VOLTAGE

These are the largest voltage magnitudes that can be supplied to V_{CC} from GND during programming or transient switching. This voltage should not be used as a DC voltage bias for an extended time.

FORWARD AND REVERSE OUTPUT VOLTAGE

The Forward Output Voltage, V_{IOUT} , should be no greater than $V_{CC} + 0.5$ up to 6.5 V. This is the greatest voltage that the output can be biased with from GND during programming or transient switching. The Reverse Output Voltage, V_{RIOUT} , should not drop below -0.5 V during programming or transient switching. These voltages should not be used as a DC voltage bias for an extended time.

FORWARD AND REVERSE INPUT VOLTAGE

The Forward Input Voltage, V_{OI} , should be no greater than $V_{CC} + 0.5$ V, up to 6.5 V. This is the greatest voltage that the input can be applied during programming or transient switching. The Reverse Input Voltage, V_{ROI} , should not drop below -0.5 V during programming or transient switching.

OUTPUT SOURCE AND SINK CURRENT

This is the maximum current that V_{IOUT} can passively sink or source before damage may occur.

AMBIENT TEMPERATURE (T_A)

This is the ambient temperature of the device. The Operating Ambient Temperature Range is the ambient temperature range in which the Common Electricals and Common Performance Characteristics limits are valid.

DEFINITIONS OF OPERATING AND PERFORMANCE CHARACTERISTICS

Zero Current Voltage Output ($V_{IOUT(Q)}$, QVO)

Zero Current Voltage Output or $V_{IOUT(Q)}$ (also called QVO) is defined as the voltage on the output, V_{IOUT} , when 0 A are applied through I_P .

QVO Temperature Drift (V_{QE})

QVO Temperature Drift, or V_{QE} , is defined as the drift of QVO from room to hot or room to cold (25°C to 150°C or 25°C to -40°C respectively). To improve over temperature performance the temperature drift is compensated with Allegro's factory trim to remain within the limits across temperature.

Reference Voltage (V_{REF})

There is a Voltage Reference Output, (V_{REF}) on the ACS37002LMC. This output reports the zero-current voltage for the output channel V_{IOUT} allowing for differential measurement and a device referred supply for the VOC pin.

Reference Voltage Temperature Drift (V_{RE})

Reference Voltage Temperature Drift, or V_{RE} , is defined as the drift of V_{REF} from room to hot or room to cold (25°C to 150°C or 25°C to -40°C respectively).

Offset Voltage (V_{OE})

Offset Voltage, or V_{OE} , is defined as the difference between QVO and V_{REF} (see Figure 6). V_{OE} includes the drift of QVO minus V_{REF} from room to hot or room to cold (25°C to 150°C or 25°C to -40°C respectively).

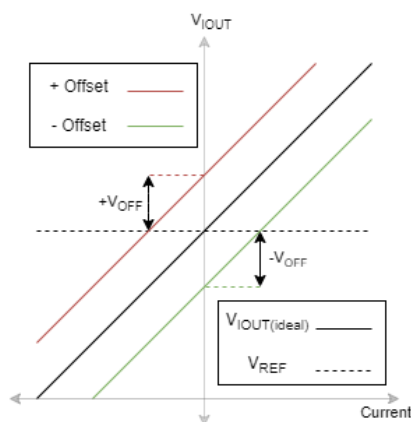

Figure 6: Offset (V_{OFF}) Between V_{IOUT} and V_{REF}

Output Saturation Voltage ($V_{SAT(HIGH/LOW)}$)

Output Saturation Voltage, or V_{SAT} , is defined as the voltage that V_{IOUT} does not pass as a result to an increasing magnitude of current. $V_{SAT(HIGH)}$ is the highest voltage the output can drive to while, $V_{SAT(LOW)}$ is the lowest. This can be seen in Figure 7. Note that changing the sensitivity does not change the V_{SAT} points.

OUTPUT VOLTAGE OPERATING RANGE (V_{OOR})

The Output Voltage Operating Range, or V_{OOR} , is the functional range for linear performance of V_{IOUT} and its related datasheet parameters. This can be seen in Figure 7. The V_{OOR} is the output region that the performance accuracy parameters are valid. It is possible for the output to report beyond these voltages until V_{SAT} . The output performance is demonstrated in Figure 7 through and beyond the V_{OOR} .

Voltage Output Operating Range for V_{CC} and Output Modes, $V_{OOR}(V_{CC}, Mode)$		
V_{CC} (V)	Bidirectional	Unidirectional
3.3	± 1.32	+2.64
5	± 2	+4

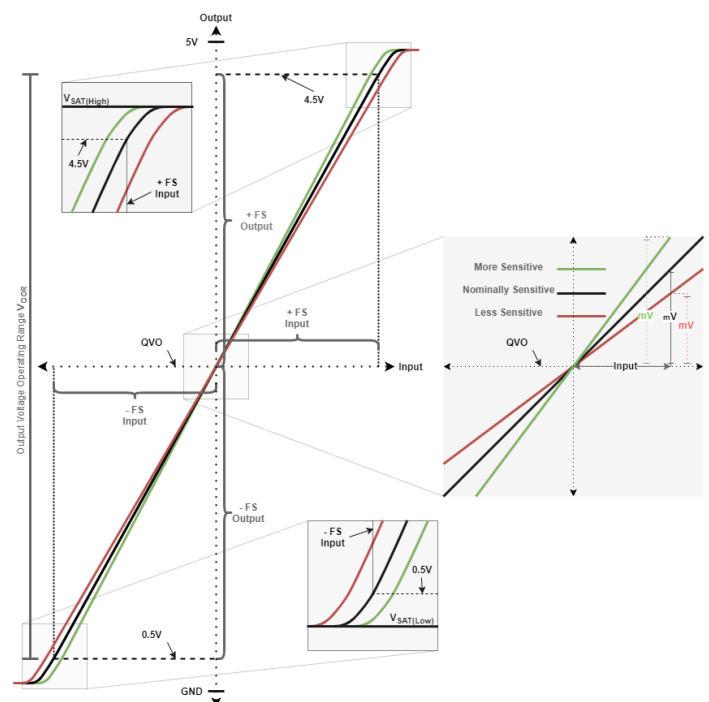

Figure 7: V_{OOR} , V_{SAT} and SENS with Full Scale

Sensitivity (Sens)

Sensitivity, or Sens, is the ratio of the output swing versus the applied current through the primary conductor, I_P . This current causes a voltage deviation away from QVO on the V_{IOUT} output until V_{SAT} . The magnitude and direction of the output voltage swing is proportional to the magnitude and direction of the applied current. This proportional relationship between output and input is Sensitivity and is defined as:

$$Sens = \frac{V_{IOUT(IP1)} - V_{IOUT(IP2)}}{I_{P1} - I_{P2}}$$

where I_{P1} and I_{P2} are two different currents, and $V_{IOUT(IP1)}$ and $V_{IOUT(IP2)}$ are the voltages of the device at the applied currents. $V_{IOUT(IP1)}$ or $V_{IOUT(IP2)}$ can be QVO with zero current.

Sensitivity Error (E_{sens})

Sensitivity Temperature Drift, or E_{sens} , is the drift of Sens from room to hot or room to cold (25°C to 150°C or 25°C to -40°C, respectively). No trimming/programming is needed as temperature drift is compensated with Allegro's factory trim to remain within the datasheet limits across temperature.

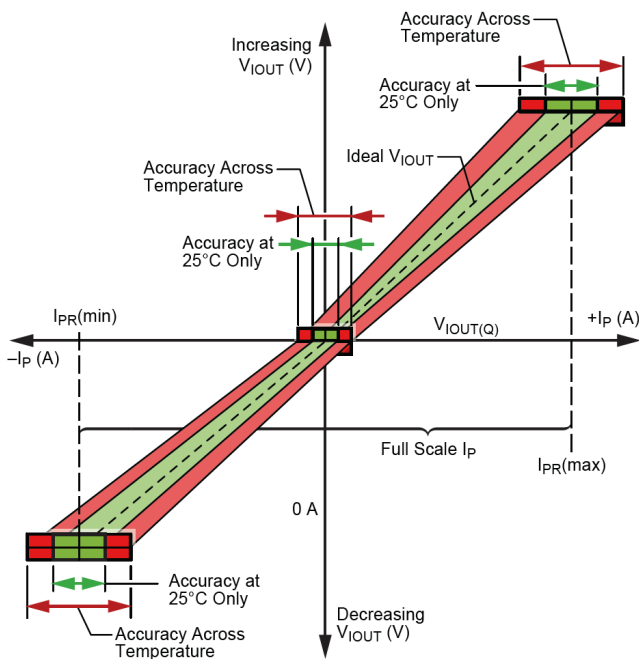

Figure 8: Output Accuracy Pocket for Room and Across Temperature

Gain Selection Pins

The ACS37002LMC features external gain selection pins that configure the device sensitivity. The gain select logic is latched based on the pin voltage at startup. Either pin may be shorted directly to VCC or GND, which is logic 1 or 0 respectively. Both pins include an internal 1 MΩ pull-down resistor to GND. Externally floating pins will be interpreted as logic 0; if both pins are floating, the device will be in the 00 configuration. Specific gain select performance can be found in the selection Performance Characteristics table. To change the gain of the device, refer to Figure 18 in the Application and Theory section.

Full Scale (FS)

Full Scale, or FS, is a method to relate an input and/or output to the max input and/or output of the device. For example, 50%FS of a 50 A sensor is 25 A, or 50% of its maximum input current. The 50% input of 25 A will cause the output to move 50%, or 50%FS. FS is used to interchangeably refer to input and output deviations when discussing input steps, fault trip thresholds and relating input to output performance. FS_{INPUT} is the input bias that results in FS_{OUTPUT} and these two are directly related by the device actual sensitivity. Both FS can be seen in Figure 7, labeled as positive or negative FS input and FS output. The equation for input referred FS for a 5 V bidirectional device is:

$$FS = V_{OOR(5V,Bi)} / Sens_{Actual} = \pm 2V / Sens_{Actual}$$

Note: that a percentage change in FS_{INPUT} is equivalent to a resultant percentage change of FS_{OUTPUT} and visa versa.

Nonlinearity (E_{LIN})

As the amount of field applied to the part changes, the sensitivity of the device can also change slightly. This is referred to as linearity error or E_{LIN} (see Figure 9). Consider two currents, I_{P1} (1/2 FS) and I_{P2} (FS). Ideally, the sensitivity of the device is the same for both fields. Linearity Error is calculated as the percent change in sensitivity from one field to another. Error is calculated separately for positive ($E_{LIN(+)}$) and negative ($E_{LIN(-)}$) currents, and the percent errors are defined as:

$$E_{LIN(\pm)} = \left(1 - \frac{Sens_{IP2\pm}}{Sens_{IP1\pm}} \right) \times 100\%$$

where:

$$Sens_{IPX+} = (V_{IOUT(IPX+)} - V_{REF}) / I_{PX+}$$

and

$$Sens_{IPX-} = (V_{IOUT(IPX-)} - V_{REF}) / I_{PX-}$$

I_{PX+} and I_{PX-} are positive and negative currents through I_P , such that $|I_{P2+}| = 2 \times |I_{P1+}|$ and $|I_{P2-}| = 2 \times |I_{P1-}|$. $E_{LIN} = \max(E_{LIN(+)}, E_{LIN(-)})$.

Total Output Error (E_{TOT})

The Total Output Error is the current measurement error from the sensor IC as a percentage of the actual applied current. This is equivalent to the difference between the ideal output voltage and the actual output voltage, divided by the ideal sensitivity, relative to the current applied to the device, or simplified to:

$$E_{TOT(\pm)} = \left(1 - \frac{V_{IOUT_Actual(\pm I_P)}}{V_{IOUT_Ideal(\pm I_P)}} \right) \times 100\%$$

where

$$V_{IOUT_Actual(\pm I_P)} = \pm I_P \times Sens_{Actual} + QVO_{Actual}$$

and

$$V_{IOUT_Ideal(\pm I_P)} = \pm I_P \times Sens_{Ideal} + V_{REF_Actual}$$

Total Output Error incorporates all sources of error and is a function of current. At relatively high currents, Total Output Error will be largely due to sensitivity error, and at relatively low inputs, Total Output Error will be mostly due to Offset Voltage (V_{OE}). At $I_P = 0$ A, Total Output Error approaches infinity due to the offset. An example of total error at FS can be seen in Figure 9.

Note: Total Output Error goes to infinity as the amount of applied field approaches 0 A.

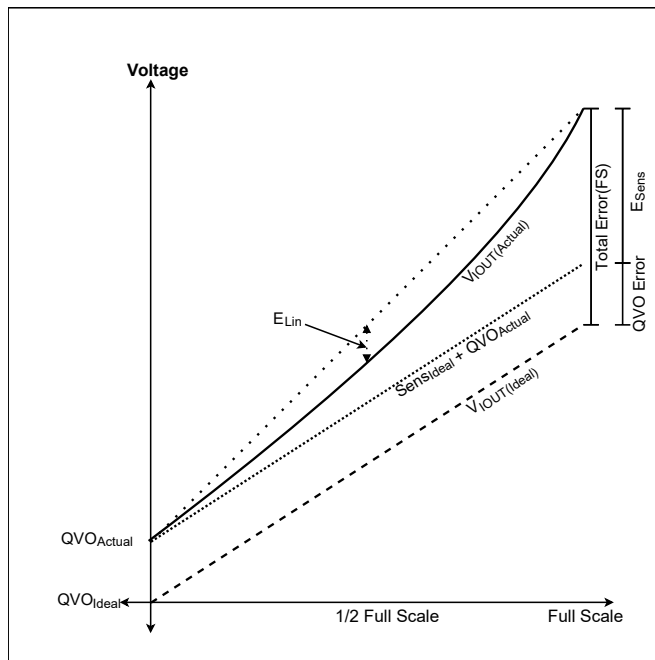

Figure 9: Accuracy Error

Power Supply Offset Error (V_{PS})

Power Supply Offset Error, V_{PS} , is defined as the offset error in mV between V_{CC} and $V_{CC} \pm 10\% V_{CC}$.

Offset Power Supply Rejection Ratio ($PSRR_O$)

The Offset Power Supply Rejection Ratio, $PSRR_O$, is defined as $20 \times \log$ of the ratio of the change of QVO in volts over a ± 100 mV variable AC V_{CC} centered at 5 V, reported as dB in a specified frequency range. This is an AC version of the V_{PS} parameter. The equation is shown below:

$$PSRR_O = 20 \log \left(\frac{\Delta QVO}{\Delta V_{CC}} \right)$$

Power Supply Sensitivity Error (E_{PS})

Power Supply Sensitivity Error, or E_{PS} , is defined as the percent sensitivity error measured between V_{CC} and $V_{CC} \pm 10\%$.

Sensitivity Power Supply Rejection Ratio ($PSRR_S$)

The Sensitivity Power Supply Rejection Ratio, $PSRR_S$, is defined as $20 \times \log$ of the ratio of the % change in sensitivity over the % change in V_{CC} (± 100 mV variable AC V_{CC} centered at 5 V), reported as dB in a specified frequency range. This is the AC version of the E_{PS} parameter. The equation is shown below:

$$PSRR_S = 20 \log \left(\frac{\Delta \% SENS}{\Delta \% V_{CC}} \right)$$

FAULT BEHAVIOR

Overcurrent Fault (OCF)

As the output swings, the Overcurrent Fault pin will trigger with an active low flag if the sensed current exceeds its comparator threshold. This is internally compared with either the factory-programmed thresholds or via the VOC voltage when $V_{VOC} > 0.1$ V. This flag trips symmetrically for the positive and negative OCF operating point.

The implementation for the OCF circuitry is accurate over temperature and does not require further temperature compensation as it is dependent on the Sens and V_{OFF} parameters that are factory-trimmed flat over temperature.

OVERCURRENT FAULT OPERATING RANGE/POINT (I_{OCF-OR} , I_{OCF-OP})

Overcurrent Fault Operating Range is the functional range that the OCF thresholds can be set in terms of percentage of full-scale output swing. The Overcurrent Fault Operating Point is the specific point at which the OCF trigger will occur and is set by either V_{VOC} or the factory default setting. The I_{OCF-OP} can be seen in Figure 10 as [9] along with the FAULT pin functionality.

OVERCURRENT FAULT HYSTERESIS ($I_{OCF(HYS)}$)

Overcurrent Fault Hysteresis or $I_{OCF(HYS)}$ is defined as the magnitude of percent FS that must drop before a fault assertion will be cleared. This can be seen as the separation between the voltages [9] to [10] in Figure 10. Note the MASK and HOLD functionality are independent of each other. The ACS37002LMC comes standard with an OCF_{HYS} of 120 mV (on the output) or 6%FS for a 5 V device and 9%FS for a 3.3 V device.

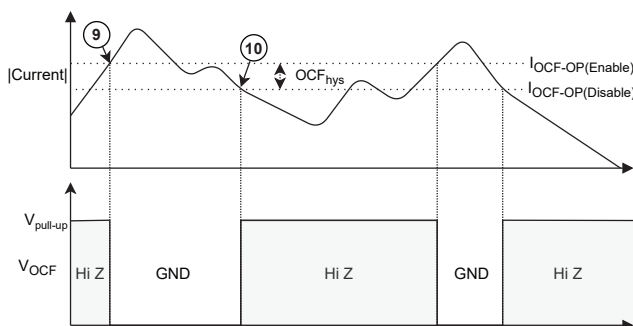

Figure 10: Fault Thresholds and OCF Pin Functionality

VOLTAGE OVERCURRENT PIN (VOC)

The fault trip points can be set using the VOC pin as the direct analog input for the fault trip point. The VOC pin voltage can be set using resistor dividers from V_{REF} on bidirectional devices. The fault performance is valid when V_{VOC} is within the VOC Operating Voltage Range or <0.1 V. The device will respond to voltage outside of the defined valid performance region with varied results. For a 5 V bidirectional device, setting the VOC pin to 0.5 V selects the minimum trip point, $I_{FAULT(min)}$, and setting the pin to 2 V selects the maximum trip point, $I_{FAULT(max)}$ as defined by selection performance tables. All voltages between 0.5 to 2 V for 5 V option and 0.33 to 1.321 V for 3.3 V option can linearly select a trip point between the minimum and maximum levels, as shown in Figure 11. When $V_{OC} < 0.1$ V, the internal EEPROM fault level will be used.

The resulting equation for the fault is:

$$OCF_{\%FS} [\%] = \frac{V_{OC(VCC)} [V]}{V_{OC(VCC)100\%} [V]} \times 100 [\%]$$

$$I_{OCF} [A] = OCF_{\%FS} [\%] \times I_{PR} [A]$$

Table 1: $V_{OC(VCC)}$ thresholds and corresponding percentage of the Full-Scale Output for Bidirectional and Unidirectional operational modes

$V_{OC(3.3V)}$ (V)	$V_{OC(5V)}$ (V)	Fault Operation Point %FS	
		Bidirectional	Unidirectional
<0.1		100% (factory default)	50% (factory default)
0.330	0.5	50%	25%
0.466	0.75	75%	37.5%
0.661	1	100%	50%
0.826	1.25	125%	62.5%
0.991	1.5	150%	75%
1.156	1.75	175%	85%
1.321	2	200%	100%

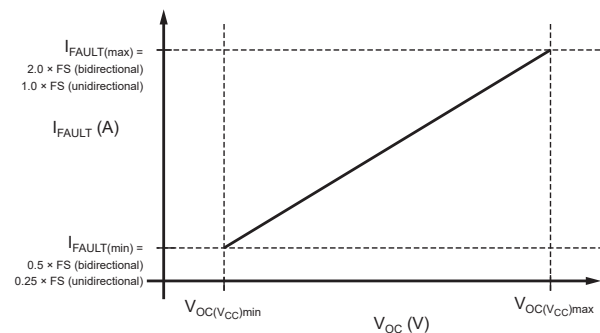

Figure 11: VOC Functional Range

OVERCURRENT FAULT ERROR (E_{OCF})

Fault Error or E_{OCF} is the error between the $I_{OCF-OP(actual)}$ and $I_{OCF-OP(ideal)}$.

OVERCURRENT FAULT RESPONSE TIME (t_{OCF})

Overcurrent Response Time or t_{OCF} is defined as the time from the input reaches the operating point [9] (seen in Figure 12) until the OCF pin falls below $V_{FAULT-ON}$ [G]. If the OCF Mask is disabled, then t_{OCF} is equal to t_{OCF-R} seen as the time from [9] until [F].

OVERCURRENT FAULT REACTION TIME (t_{OCF-R})

Overcurrent Reaction Time or t_{OCF-R} is defined as the time from the current input rising above I_{OCF-OP} at point [9] in Figure 12 until the OCF pin reaches V_{OCF-ON} at point [F] with the OCF mask disabled. This is the time required for the device to recognize and clear the fault, seen as the time between [10] until [I].

OVERCURRENT FAULT MASK TIME ($t_{OCF-MASK}$)

Overcurrent Fault Mask Time or $t_{OCF-MASK}$ is defined as the additional amount of time the OCF must be present beyond the t_{OCF-R} time (seen in Figure 12 [F] until [G]). This is to reduce nuisance tripping of the FAULT pin. If an OCF occurs, but does not persist beyond $t_{OCF-R} + t_{OCF-MASK}$, it is not reported by the device (seen in Figure 13). This prevents short transient spikes from causing erroneous OCF flagging. Factory default setting is $t_{OCF-MASK} = 0 \mu s$.

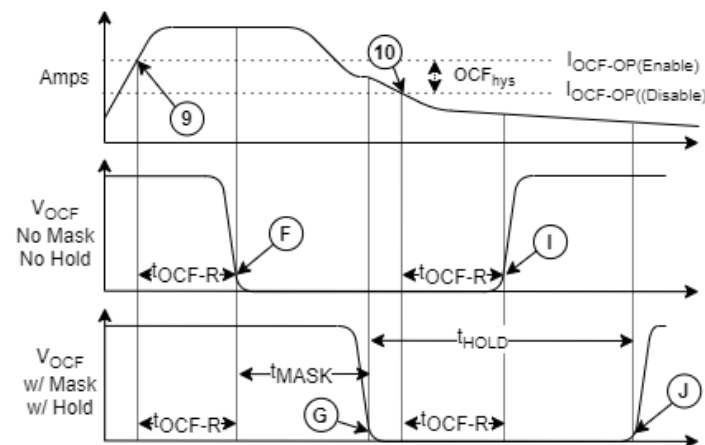

Figure 12: General Fault Timing.
Note: the MASK and HOLD functionality are independent of each other

OVERCURRENT FAULT HOLD TIME ($t_{OCF-HOLD}$)

Overcurrent Fault Hold Time or $t_{OCF-HOLD}$ is defined as the minimum time OCF flag will be asserted after a sufficient OCF event. After the hold time has been reached, the OCF will release if the OCF condition has ended (seen in Figure 12 [G] until [J]) or persist if the OCF condition is still present (seen in Figure 14 [G] until [J]). Factory default is 0 ms.

OVERCURRENT FAULT PERSIST

The ACS37002LMC has a fault persist option that will maintain the OCF flag if a flag occurred until a POR event.

OCF DISABLE

The ACS37002LMC has the ability to disable overcurrent fault functionality; when this is disabled, the OCF pin will remain in high impedance.

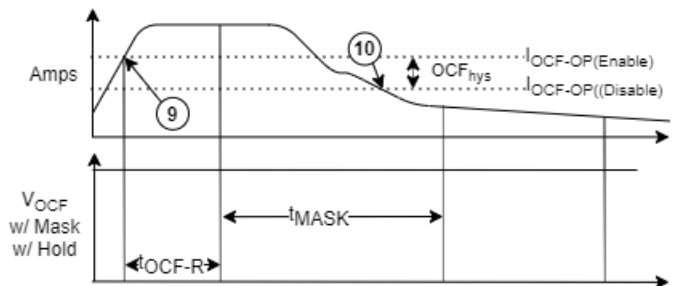

Figure 13: Fault Condition Clearing Before Mask Time Is Reached

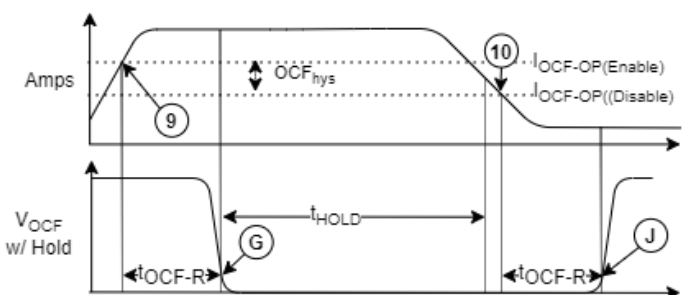

Figure 14: Fault Hold with Clear Fault After Hold Time

DYNAMIC RESPONSE PARAMETERS

The descriptions in this section use the listed test conditions and assume a temperature of 25°C. The step applied is a input step that corresponds to 1 V deviation on the output, unless otherwise stated.

Propagation Time (t_{PD})

The time interval between a) when the sensed current reaches 10% of its stable value, and b) when the sensor output reaches 10% of its stable value for a step input. See Figure 15.

Rise Time (t_r)

The time interval between a) when the sensor reaches 10% of its stable value, and b) when it reaches 90% of the stable value for a step input. See Figure 15.

Response Time ($t_{RESPONSE}$)

The time interval between a) when the sensed current reaches 90% of its stable value, and b) when the sensor output reaches 90% of its stable value. See Figure 15.

Temperature Compensation

To help compensate for the effects temperature has on performance, the ACS37002LMC has an integrated internal temperature sensor. This sensor and compensation algorithms help to standardize device performance over the full range of optimized temperatures. This allows for room temperature system calibration and validation of end-of-line modules.

Temperature Compensation Update Rate

There is an 8 ms update time that is required to maintain a valid temperature compensated output; that is, temperature compensations are calculated and applied every 8 ms.

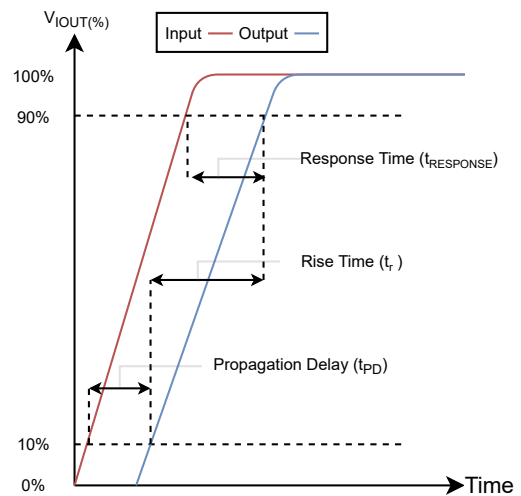

Figure 15: Dynamic Response Parameters

APPLICATION AND THEORY

Application Circuits

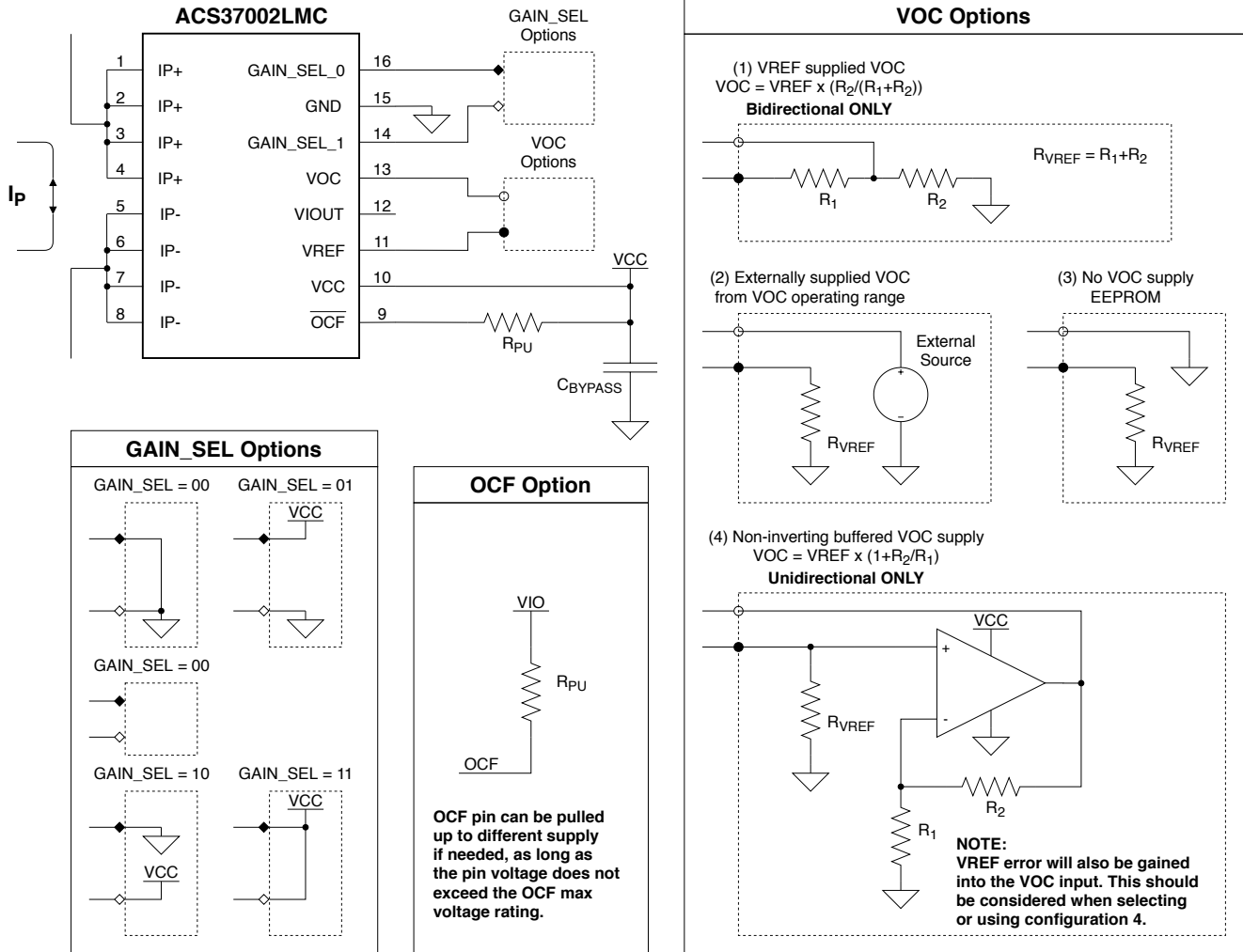

Figure 16: Applications Circuits for GAIN_SEL, VOC, and FAULT pin

These configurations are simplified to the network required for functionality.

Bypass and load capacitors are recommended for best performance.

Theory and Functionality – VOC and OCF

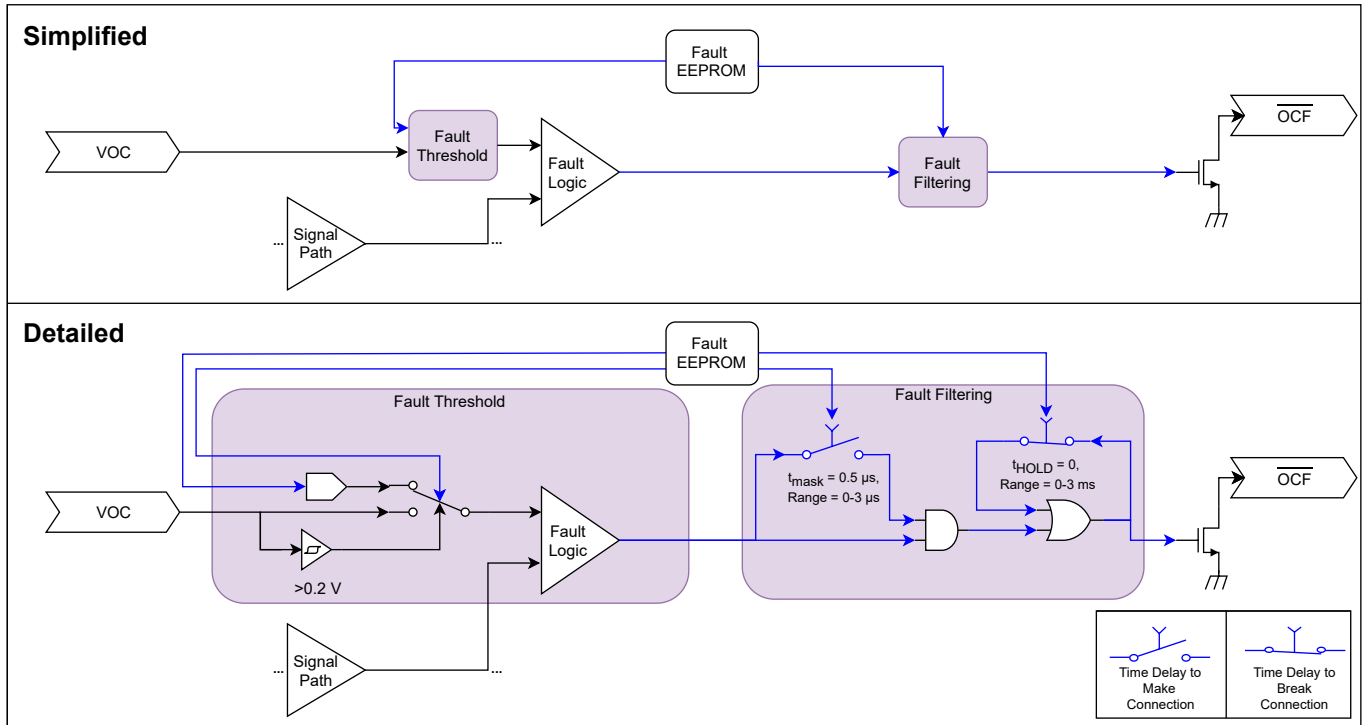

Figure 17: OCF Signal Path Simplified and Detailed Blocks of Functionality

VOC DRIVEN BY NON-INVERTING BUFFERED VREF

If the VOC pin is being driven by a non-inverted buffered V_{REF} , it is important to consider that any error from the V_{REF} pin will be gained as well. For instance, if V_{REF} error is +10 mV and the gain = 4 for the non-inverting operational amplifier, then the VOC pin will be 40 mV from the expected target. For unidirectional devices, OCF would be subjected to an additional 4% error due to the error propagation from V_{REF} through the gain stage.

POWER SUPPLY DECOUPLING CAPACITOR AND OUTPUT CAPACITIVE LOADS

The higher the capacitive load on the outputs (V_{REF} , V_{IOUT}), the larger the decoupling capacitor should be on the power supply (V_{CC}) to maintain performance.

C_{LOAD}	C_{BYPASS}
0 nF	100 nF
1 nF	>100 nF
3 nF	>1 μF
6 nF	>10 μF

Dynamically Change Gain in a System

The ACS37002LMC has GAIN_SEL pins that are used to change the gain of the device on startup. If a more dynamic gain is desired, then reduce V_{CC} below $V_{POR(L)}$ and restart the device by returning V_{CC} to the nominal voltage with the new desired GAIN_SEL configuration. The GAIN_SEL pin voltage

must greater than the desired configuration voltage ($V_{H(SEL)}$ or $V_{L(SEL)}$) at or before $V_{CC} > V_{POR(H)}$ in order to successfully change the device gain. The GAIN_SEL pin voltage is latched at startup, and any changes to the pin voltages after the devices V_{IOUT} comes out of high impedance will not affect gain. The cycle time to complete this operation is up to $2 \times t_{POD}$.

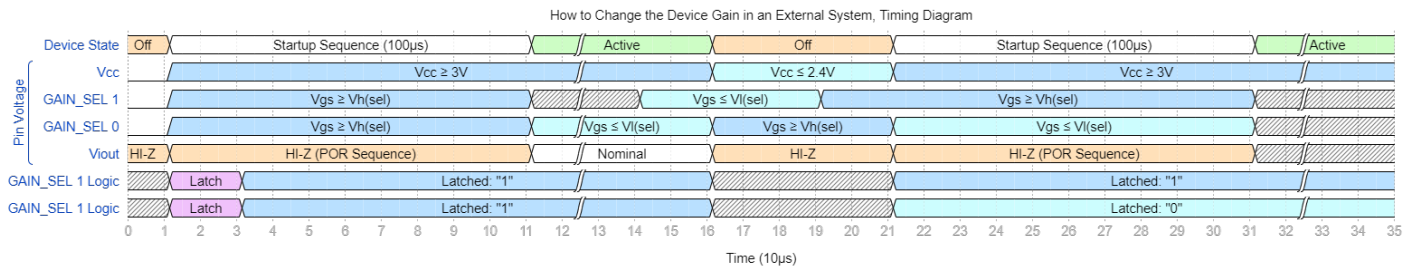

Figure 18: GAIN_SEL Dynamic Gain Changing Timing Diagram

PACKAGE OUTLINE DRAWING

PRELIMINARY

For Reference Only; not for tooling use (reference DWG-0000714, Rev. 1)
 Dimensions in millimeters
 Dimensions exclusive of mold flash, gate burrs, and dambar protrusions
 Exact case and lead configuration at supplier discretion within limits shown

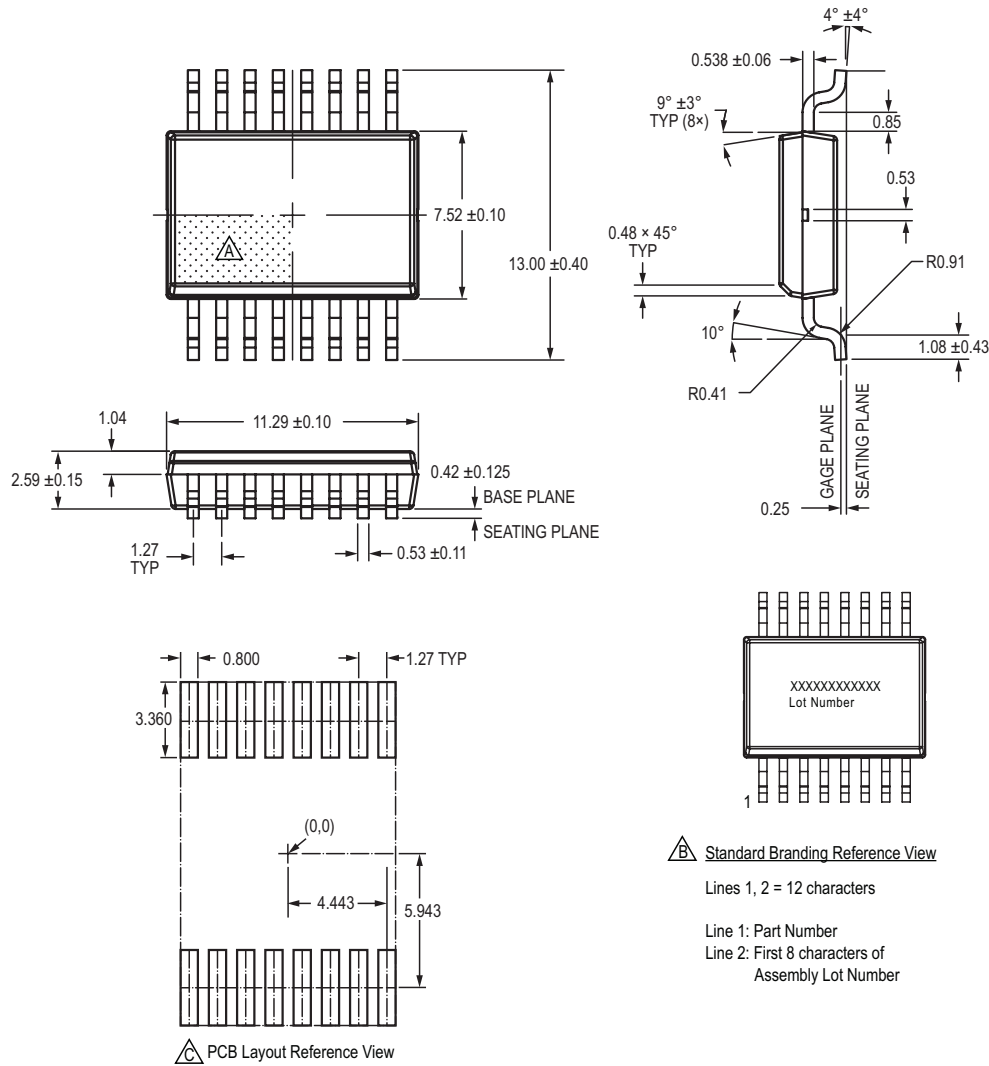

Figure 19: Package MC, 16-Pin SOICW

ACS37002LMC

400 kHz, High Accuracy Current Sensor with Pin-Selectable Gains and Adjustable Overcurrent Fast Fault in SOICW-16 Package

Revision History

Number	Date	Description
-	December 14, 2020	Initial release

Copyright 2020, Allegro MicroSystems.

Allegro MicroSystems reserves the right to make, from time to time, such departures from the detail specifications as may be required to permit improvements in the performance, reliability, or manufacturability of its products. Before placing an order, the user is cautioned to verify that the information being relied upon is current.

Allegro's products are not to be used in any devices or systems, including but not limited to life support devices or systems, in which a failure of Allegro's product can reasonably be expected to cause bodily harm.

The information included herein is believed to be accurate and reliable. However, Allegro MicroSystems assumes no responsibility for its use; nor for any infringement of patents or other rights of third parties which may result from its use.

Copies of this document are considered uncontrolled documents.

For the latest version of this document, visit our website:

www.allegromicro.com