

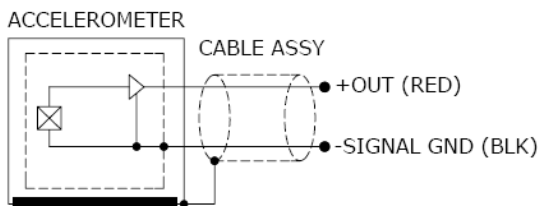

dimensions

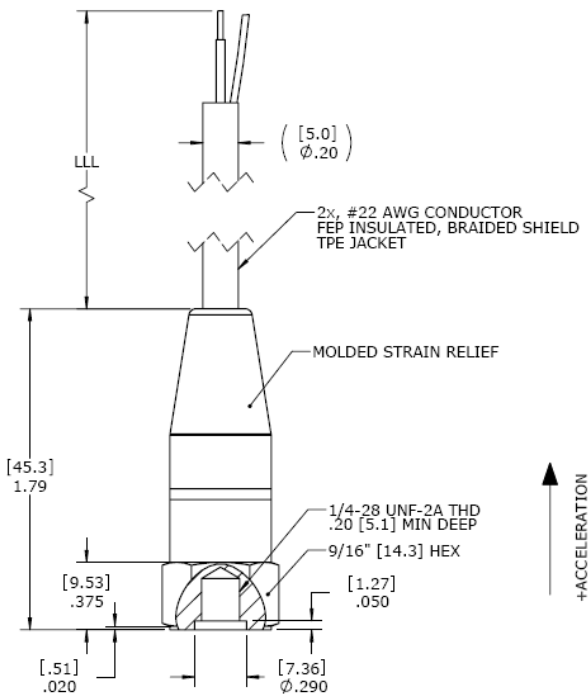

MODEL 8032-01 ACCELEROMETER

SPECIFICATIONS

- ◆ Low Cost Industrial Accelerometer
- ◆ 12kHz Bandwidth.
- ◆ -55°C to +100°C Operating Range
- ◆ Integral Cable, Molded Strain Relief

The Model 8032-01 is an internally shielded rugged IEPE accelerometer designed for harsh environments. The accelerometer is available in ± 50 to $\pm 500g$ dynamic ranges and has a flat bandwidth up to greater than 12kHz. The model 8032-01 features an integral molded strain relief and is designed to operating in temperature ranges from -55°C to +100°C. The unit features the popular stud mount installation.

FEATURES

- ◆ $\pm 50g$ to $\pm 500g$ Dynamic Range
- ◆ Wide bandwidth up to 12kHz
- ◆ Case Isolated, Internally Shielded
- ◆ Reverse Wiring Protection
- ◆ Stable Temperature Response
- ◆ Integral Cable, Molded Strain Relief

APPLICATIONS

- ◆ General Purpose
- ◆ Machine Monitoring
- ◆ Industrial Applications
- ◆ Harsh Environments
- ◆ Gearbox Monitoring

PERFORMANCE SPECIFICATIONS

All values are typical at +24°C, 80Hz and 4mA excitation unless otherwise stated. Measurement Specialties reserves the right to update and change these specifications without notice.

Parameters

DYNAMIC

			Notes
Range (g)	±50	±500	
Sensitivity (mV/g)	100	10	±10%
Frequency Response (Hz)	1-8000	1-8000	±1dB
Frequency Response (Hz)	0.4-10000	0.4-12000	±3dB
Natural Frequency (Hz)	47000	47000	
Non-Linearity (%FSO)	±1	±1	
Transverse Sensitivity (%)	<7	<7	
Shock Limit (g)	5000	5000	
Residual Noise (g RMS)	0.0004	0.0009	Broadband 1Hz to 10kHz
Spectral Noise, 10Hz (µg√Hz)	12	25	
Spectral Noise, 100Hz (µg√Hz)	7.5	15	
Spectral Noise, 1kHz (µg√Hz)	3.5	8	

ELECTRICAL

Compliance Voltage (Vdc)	18 to 30		
Excitation Current (mA)	2 to 10		
Bias Voltage (Vdc)	8 to 12		Room Temperature
Bias Voltage (Vdc)	6 to 14		-55 to +100°C
Output Impedance (Ω)	<100		
Insulation Resistance (MΩ)	>100		@100Vdc
Warm-up Time (sec)	<2		
Grounding	Case Isolated, Internally Shielded		

ENVIRONMENTAL

Temperature Response (%)	±5	
Operating Temperature (°C)	-55 to +100	
Storage Temperature (°C)	-55 to +100	
Humidity	Environmentally Sealed, Molded, IP67	

PHYSICAL

Sensing Element	Ceramic
Cable	FEP Insulated Leads, Braided Shield, TPE Jacket
Case Material	Stainless Steel
Weight (grams)	90
Mounting	¼-28 to ¼-28 Mounting Stud (included)
Mounting Torque	24 lb-in (2.7 N-m)

Calibration supplied:	CS-SENS-0100	NIST Traceable Amplitude Calibration at 100Hz
Supplied accessories:	AC-A03663	¼-28 to ¼-28 mounting stud
Optional accessories:	CS-FREQ-0100	NIST Traceable Amplitude Calibration from 20Hz to ±3dB Frequency Response Limit
	AC-D03664	¼-28 to M5 mounting stud
	AC-D03665	¼-28 to M6 mounting stud

The information in this sheet has been carefully reviewed and is believed to be accurate; however, no responsibility is assumed for inaccuracies. Furthermore, this information does not convey to the purchaser of such devices any license under the patent rights to the manufacturer. Measurement Specialties, Inc. reserves the right to make changes without further notice to any product herein. Measurement Specialties, Inc. makes no warranty, representation or guarantee regarding the suitability of its product for any particular purpose, nor does Measurement Specialties, Inc. assume any liability arising out of the application or use of any product or circuit and specifically disclaims any and all liability, including without limitation consequential or incidental damages. Typical parameters can and do vary in different applications. All operating parameters must be validated for each customer application by customer's technical experts. Measurement Specialties, Inc. does not convey any license under its patent rights nor the rights of others.

Typical Frequency Response

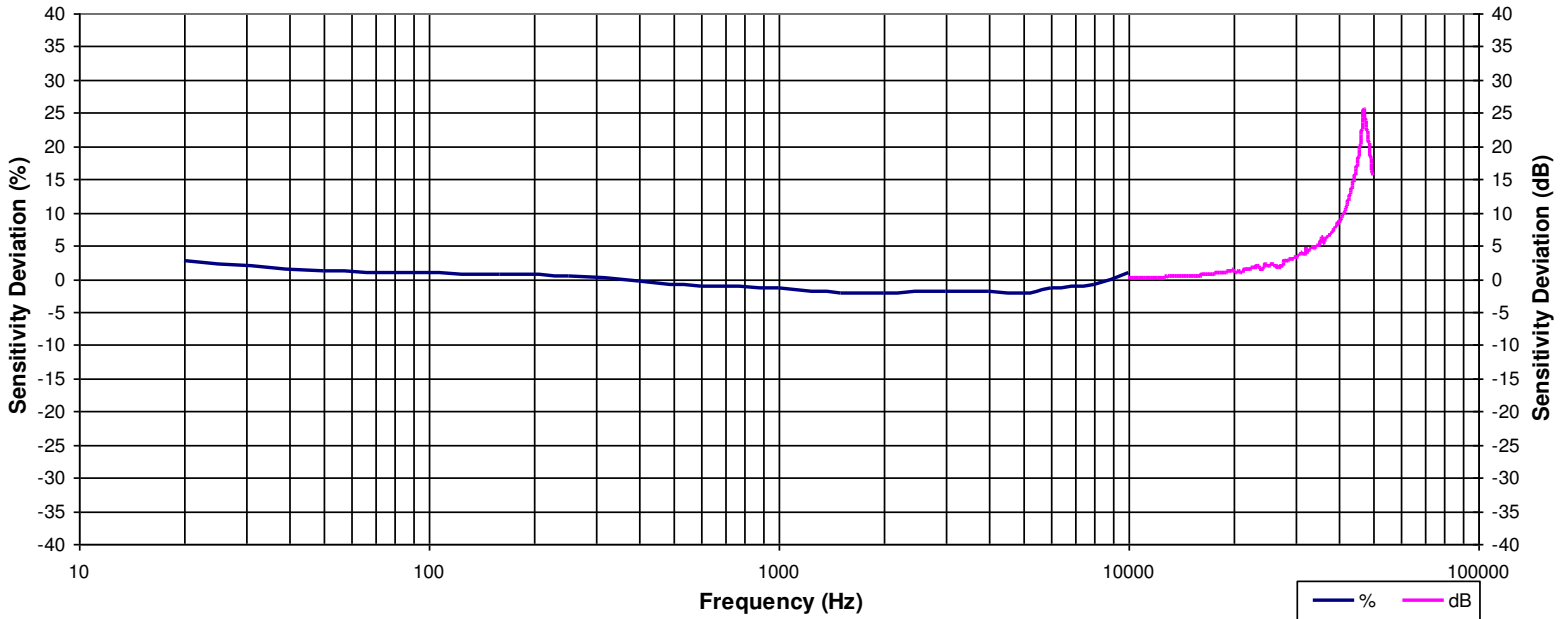

ORDERING INFORMATION

PART NUMBERING Model Number+Range+Cable Length

8032-01-GGGG-ZZZ

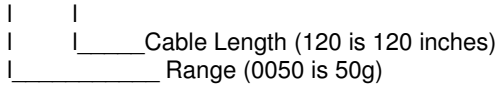

Example: 8032-01-0050-120
 Model 8032-01, 50g, 120inch (10ft) cable length

NORTH AMERICA

Measurement Specialties, Inc.,
 a TE Connectivity Company
 Tel: 800-522-6752
 Email: customercare.hmpt@te.com

EUROPE

MEAS France SAS
 a TE Connectivity Company
 Tel: 800-440-5100
 Email: customercare.lcsb@te.com

ASIA

Measurement Specialties (China), Ltd.,
 a TE Connectivity Company
 Tel: 0400-820-6015
 Email: customercare.shzn@te.com

TE.com/sensorsolutions

Measurement Specialties, Inc., a TE Connectivity company.

Measurement Specialties, TE Connectivity, TE Connectivity (logo) and EVERY CONNECTION COUNTS are trademarks. All other logos, products and/or company names referred to herein might be trademarks of their respective owners.

The information given herein, including drawings, illustrations and schematics which are intended for illustration purposes only, is believed to be reliable. However, TE Connectivity makes no warranties as to its accuracy or completeness and disclaims any liability in connection with its use. TE Connectivity's obligations shall only be as set forth in TE Connectivity's Standard Terms and Conditions of Sale for this product and in no case will TE Connectivity be liable for any incidental, indirect or consequential damages arising out of the sale, resale, use or misuse of the product. Users of TE Connectivity products should make their own evaluation to determine the suitability of each such product for the specific application.

© 2015 TE Connectivity Ltd. family of companies All Rights Reserved.