

## Precision Angle Sensor IC with Incremental and Motor Commutation Outputs and On-Chip Linearization

### FEATURES AND BENEFITS

- Contactless 0° to 360° angle sensor IC, for angular position, rotational speed, and direction measurement
  - Capable of sensing magnet rotational speeds targeting 12.5-bit effective resolution with 300 G field; higher effective resolution possible at higher field strengths
  - Circular Vertical Hall (CVH) technology provides a single channel sensor system, with air gap independence
- On-chip 32 segment linearization to improve angle accuracy
  - Reduces impact of magnet to sensor misalignment
  - Reduces impact of imperfect magnetization of target magnet
- Developed as a Safety Element out of Context (SEooC) in accordance with ISO 26262:2011 requirements for hardware product development for use in safety-critical applications (pending assessment)
  - Single die version designed to meet ASIL B requirements when integrated and used in conjunction with the appropriate system-level control, in the manner prescribed in the AAS33001 Safety Manual
  - Dual die version designed to meet ASIL D requirements when integrated and used in conjunction with the appropriate system-level control, in the manner prescribed in the AAS33001 Safety Manual

*Continued on next page...*

### PACKAGES

24-pin eTSSOP (Suffix LP)

14-pin TSSOP (Suffix LE)

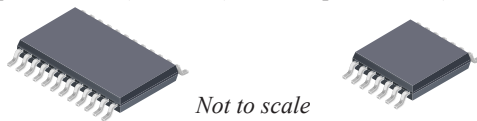

### DESCRIPTION

The AAS33001 is a 360° angle sensor IC that provides contactless high-resolution angular position information based on magnetic circular vertical Hall (CVH) technology. It has a system-on-chip (SoC) architecture that includes: a CVH front end, digital signal processing to calculate the angular position information, and multiple output formats: serial protocol (SPI), pulse-width modulation (PWM), and either motor commutation (UVW) or encoder outputs (A, B, I). It also includes on-chip EEPROM technology, capable of supporting up to 100 read/write cycles, for flexible programming of calibration parameters. The AAS33001 is ideal for automotive applications requiring 0° to 360° angle measurements, such as electronic power steering (EPS), electronic power braking (EPB or IDB), transmission actuators, and BLDC pumps.

The AAS33001 includes on-chip 32 segment linearization. This can be used to calibrate out errors due to misalignment between the magnet and the sensor or imperfect magnetization of the target magnet (which can present itself as a misalignment of the magnet to the sensor).

The AAS33001 supports customer integration into safety-critical applications.

The AAS33001 is available in a dual-die 24-pin eTSSOP and a single-die 14-pin TSSOP package. The packages are lead (Pb) free with 100% matte-tin leadframe plating. The 1 mm thin package reduces the minimum air gap between the CVH transducer and the target magnet. The AAS33001 device is pin-compatible with the A1333 to enable easy migration.

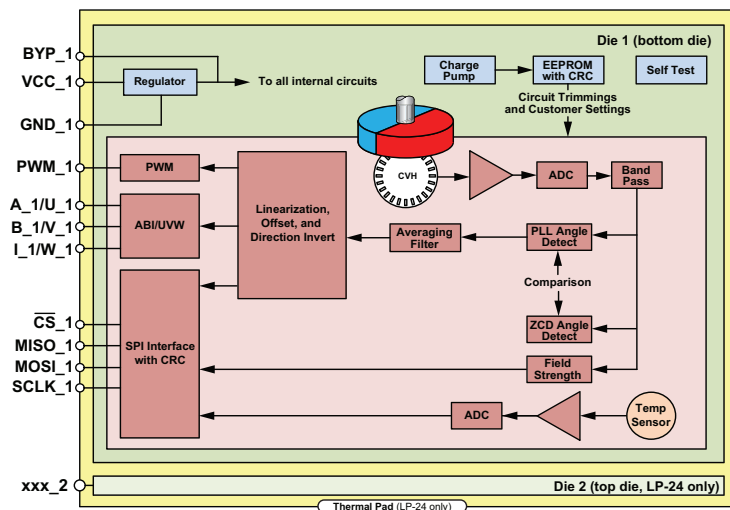
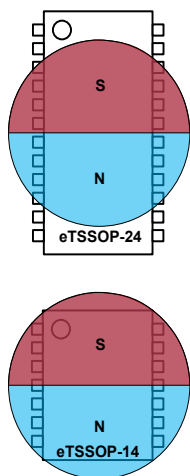

**Figure 1: AAS33001 Magnetic Circuit and IC Diagram**

## FEATURES AND BENEFITS (continued)

- High diagnostic coverage
  - On-chip diagnostics include logic built-in self-test (LBIST), signal path diagnostics, and watchdogs to support safety-critical (ASIL) applications
  - 4-bit CRC on SPI
- On-chip EEPROM for storing factory and customer calibration parameters
  - Single-bit error correction; dual-bit error detection, error correction control (ECC)
- Supports operating in harsh conditions required for automotive and industrial applications, including direct connection to 12 V battery
  - Operating temperature range from  $-40^{\circ}\text{C}$  to  $150^{\circ}\text{C}$
  - Operating supply voltage range from 3.7 to 18 V, absolute maximum of 28 V continuous
    - ◆ Can support ISO 7637-2 Pulse 5b up to 39 V
- Multiple output formats supported for ease of system integration
  - ABI and UVW interfaces provide high resolution and lowest latency angle information
  - PWM interface provides initial position for ABI/UVW interfaces
  - 10 MHz SPI for low latency angle and diagnostic information; enables multiple independent ICs to be connected to same bus
    - ◆ 5 V SPI can be supported
  - Output resolution on ABI and UVW are selectable
- Multiple programming/configuration formats supported
  - The system can be completely controlled and programmed over SPI, including EEPROM writes
  - For system with limited pins available, writing and reading can be performed over VCC and PWM pins. This allows configuring the EEPROM in production line for a device with only ABI/UVW and PWM pins connected.
- 1 mm thin surface-mount TSSOP packages for both single and dual die versions to minimize air gap from target magnet to CVH transducer for improved field strength
  - Pin-compatible to single and dual die A1333 devices
  - Stacked dual die construction to improve channel-to-channel matching for systems that require redundant sensors

## Table of Contents

Features and Benefits.....	1	EEPROM and Shadow Memory Usage.....	33
Description.....	1	Enabling EEPROM Access.....	33
Packages.....	1	EEPROM Write Lock.....	33
Simplified Block Diagram.....	1	EEPROM Access and Write Lock Exceptions.....	34
Selection Guide.....	2	Write Transaction.....	34
Absolute Maximum Ratings.....	2	Read Transaction.....	38
Thermal Characteristics.....	2	Shadow Memory Read and Write Transactions.....	40
Pinout Diagrams and Terminal List.....	4	Serial Interface Table.....	41
Operating Characteristics.....	5	Primary Serial Interface Registers Reference.....	42
Functional Description.....	8	EEPROM and Shadow Register Table.....	48
Overview.....	8	EEPROM Reference.....	49
Angle Measurement.....	8	Safety and Diagnostics.....	56
System Level Timing.....	8	Alive Counter.....	56
Power-Up.....	8	Oscillator Watchdogs.....	56
PWM Output.....	8	Logic Built-In Self-Test (LBIST).....	56
Linearization.....	12	CVH Self-Test.....	56
Incremental Output Interface (ABI).....	13	Application Information.....	57
Brushless DC Motor Commutation.....	18	Magnetic Target Requirements.....	57
ABI Behavior at Power-Up.....	20	Typical SPI and ABI/UVW Applications.....	58
Angle Hysteresis.....	21	I/O Structures.....	60
Device Programming Interface.....	22	Package Outline Drawings.....	61
Interface Structure.....	22		
SPI Interface.....	23		
Manchester Interface.....	27		

# AAS33001

## Precision Angle Sensor IC with Incremental and Motor Commutation Outputs and On-Chip Linearization

### SELECTION GUIDE\*

Part Number	System Die	Interface Voltage (V)	Package	Packing
AAS33001LLPTR-DD	Dual	3.3	24-pin eTSSOP	4000 pieces per 13-inch reel
AAS33001LLETR	Single	3.3	14-pin TSSOP	4000 pieces per 13-inch reel

\* Contact Allegro for 5 V interface variants if required.

### ABSOLUTE MAXIMUM RATINGS

Characteristic	Symbol	Notes	Rating	Unit
Forward Supply Voltage	$V_{CC}$	Sampling angles, respecting $T_J(\text{max})$	28	V
Reverse Supply Voltage	$V_{RCC}$	Not sampling angles	-18	V
All Other Pins Forward Voltage	$V_{IN}$		5.5	V
All Other Pins Reverse Voltage	$V_R$		0.5	V
Operating Ambient Temperature	$T_A$	L range	-40 to 150	°C
Maximum Junction Temperature	$T_J(\text{max})$		170	°C
Storage Temperature	$T_{stg}$		-65 to 170	°C

### THERMAL CHARACTERISTICS: May require derating at maximum conditions

Characteristic	Symbol	Test Conditions*	Value	Unit
Package Thermal Resistance	$R_{\theta JA}$	LP-24 package with exposed thermal pad; measured on JEDEC JESD51-7 2s2p board	69	°C/W
		LE-14 package; measured on JEDEC JESD51-7 2s2p board	82	°C/W

### PINOUT DIAGRAMS AND TERMINAL LIST TABLE

#### Pinout Diagrams

##### LP 24-Pin eTSSOP

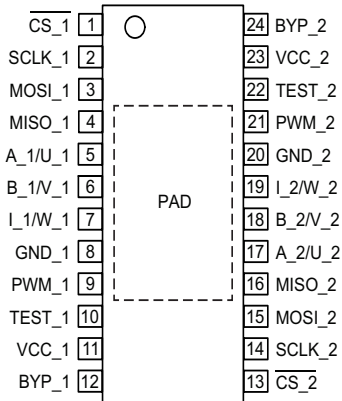

##### LE 14-Pin TSSOP

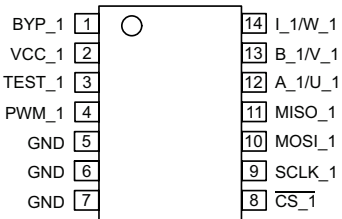

#### Terminal List Table

Pin Name	Pin Number		Function
	LE-14	LP-24	
PWM_1	4	9	PWM Angle Output (die 1)
BYP_1	1	12	External bypass capacitor terminal for internal regulator (die 1)
A_1/U_1	12	5	Option 1: Quadrature A output signal signal (die 1) Option 2: U (phase 1) output signal (die 1)
B_1/V_1	13	6	Option 1: Quadrature B output signal (die 1) Option 2: V (phase 2) output signal (die 1)
VCC_1	2	11	Power supply; also used for EEPROM programming
I_1/W_1	14	7	Option 1: Quadrature I (index) output signal (die 1) Option 2: W (phase 3) output signal (die 1)
VCC_2	-	23	Power supply; also used for EEPROM programming
MISO_2	-	16	SPI Master Input / Slave Output (die 2); also address selection for Manchester interface
SCLK_2	-	14	SPI Clock terminal input (die 2)
MOSI_2	-	15	SPI Master Output / Slave Input (die 2)
CS_2	-	13	SPI Chip Select terminal, active low input (die 2); also address selection for Manchester interface
GND	5, 6, 7	-	Device ground terminal
GND_1	-	8	Device ground terminal
GND_2	-	20	Device ground terminal
PWM_2	-	21	PWM Angle Output (die 2)
BYP_2	-	24	External bypass capacitor terminal for internal regulator (die 2)
A_2/U_2	-	17	Option 1: Quadrature A output signal (die 2) Option 2: U (phase 1) output signal (die 2)
B_2/V_2	-	18	Option 1: Quadrature B output signal (die 2) Option 2: V (phase 2) output signal (die 2)
I_2/W_2	-	19	Option 1: Quadrature I (index) output signal (die 1) Option 2: W (phase 3) output signal (die 1)
MISO_1	11	4	SPI Master Input / Slave Output (die 1); also address selection for Manchester interface
SCLK_1	9	2	SPI Clock terminal input (die 1)
MOSI_1	10	3	SPI Master Output / Slave Input (die 1)
CS_1	8	1	SPI Chip Select terminal, active low input (die 1); also address selection for Manchester interface
TEST_1	3	10	Connect to ground (die 1)
TEST_2	-	22	Connect to ground (die 2)
PAD	-	PAD	Exposed pad for thermal dissipation

**OPERATING CHARACTERISTICS:** Valid over the full operating voltage and ambient temperature ranges, unless otherwise noted

Characteristics	Symbol	Test Conditions	Min.	Typ. [1]	Max.	Unit [2]
<b>ELECTRICAL CHARACTERISTICS</b>						
Supply Voltage	$V_{CC}$		3.7	–	18	V
Supply Current	$I_{CC(full)}$	For single die	–	15	19	mA
Power-On Reset Threshold Voltage [3]	$V_{PORHI}$	$V_{CC}$ rising, $dV/dt = 1 \text{ V/ms}$ , $T_A = 25^\circ\text{C}$	–	–	3.7	V
	$V_{PORLOW}$	$V_{CC}$ falling, $dV/dt = 1 \text{ V/ms}$ , $T_A = 25^\circ\text{C}$	3.3	–	–	V
Undervoltage Warning Level [6]	$V_{UV}$	$T_A = -40^\circ\text{C}$ to $150^\circ\text{C}$	3.7	3.82	4.0	V
Supply Zener Clamp Voltage	$V_{ZSUP}$	$I_{CC} = I_{CC(AWAKE)} + 3 \text{ mA}$ , $T_A = 25^\circ\text{C}$	26.5	–	–	V
Reverse Battery Current	$I_{RCC}$	$V_{RCC} = 18 \text{ V}$ , $T_A = 25^\circ\text{C}$	–	–	5	mA
Power-On Time [4]	$t_{PO}$	Power-on diagnostics disabled, interface working, but angle not yet settled	–	300	–	$\mu\text{s}$
Bypass Pin Output Voltage [5]	$V_{BYP}$	$T_A = 25^\circ\text{C}$ , $C_{BYP} = 0.1 \mu\text{F}$	2.97	3.3	3.63	V
<b>SPI AND ABI/UVW INTERFACE SPECIFICATIONS (for 3.3 V interface)</b>						
Digital Input High Voltage	$V_{IH}$	MOSI, SCLK, $\overline{CS}$ pins	2.8	–	3.63	V
Digital Input Low Voltage	$V_{IL}$	MOSI, SCLK, $\overline{CS}$ pins	–	–	0.5	V
Output High Voltage	$V_{OH}$	MISO and ABI/UVW pins, $C_L = 20 \text{ pF}$ , $T_A = 25^\circ\text{C}$	2.93	3.3	3.63	V
Output Low Voltage	$V_{OL}$	MISO and ABI/UVW pins, $C_L = 20 \text{ pF}$ , $T_A = 25^\circ\text{C}$	–	0.3	–	V
<b>SPI AND ABI/UVW INTERFACE SPECIFICATIONS (for 5.0 V interface) (Contact Allegro for 5 V SPI ordering information)</b>						
Digital Input High Voltage	$V_{IH}$	MOSI, SCLK, $\overline{CS}$ pins	3.75	–	5.5	V
Digital Input Low Voltage	$V_{IL}$	MOSI, SCLK, $\overline{CS}$ pins	–	–	0.5	V
Output High Voltage	$V_{OH}$	MISO and ABI/UVW pins, $C_L = 20 \text{ pF}$ , $T_A = 25^\circ\text{C}$	4.0	5.0	5.5	V
Output Low Voltage	$V_{OL}$	MISO and ABI/UVW pins, $C_L = 20 \text{ pF}$ , $T_A = 25^\circ\text{C}$	–	0.3	–	V
<b>SPI INTERFACE SPECIFICATIONS</b>						
SPI Clock Frequency [6]	$f_{SCLK}$	MISOx pins, $C_L = 20 \text{ pF}$	0.1	–	10	MHz
SPI Clock Duty Cycle [6]	$D_{fSCLK}$	$SPI_{CLKDC}$	40	–	60	%
SPI Frame Rate [6]	$t_{SPI}$		5.8	–	588	kHz
Chip Select to First SCLK Edge [6]	$t_{CS}$	Time from $\overline{CS}_x$ going low to SCLKx falling edge	50	–	–	ns
Chip Select Inactive Time	$t_{CSH}$	Time in which $\overline{CS}_x$ is held high before the next frame	150	–	–	ns
Data Output Valid Time [6]	$t_{DAV}$	Data output valid after SCLKx falling edge	–	–	50	ns
MOSI Setup Time [6]	$t_{SU}$	Input setup time before SCLKx rising edge	25	–	–	ns
MOSI Hold Time [6]	$t_{HD}$	Input hold time after SCLKx rising edge	50	–	–	ns
SCLK to CS Hold Time [6]	$t_{CHD}$	Hold SCLKx high time before $\overline{CS}_x$ rising edge	5	–	–	ns
Load Capacitance [6]	$C_L$	Loading on digital output (MISOx) pin	–	–	20	pF

Continued on the next page...

**OPERATING CHARACTERISTICS (continued):** Valid over the full operating voltage and ambient temperature ranges, unless otherwise noted

Characteristics	Symbol	Test Conditions	Min.	Typ. [1]	Max.	Unit [2]
<b>PWM INTERFACE SPECIFICATIONS</b>						
PWM Carrier Frequency	$f_{\text{PWM}}$	PWM Frequency Min Setting, $T_A$ in specification	–	98	–	Hz
		PWM Programmable Options (number of steps)	–	128	–	steps
		PWM Frequency Max Setting, $T_A$ in specification	–	3.125	–	kHz
PWM Output Low Clamp	$D_{\text{PWM}(\text{min})}$	Corresponding to digital angle of 0x000	–	5	–	%
PWM Output High Clamp	$D_{\text{PWM}(\text{max})}$	Corresponding to digital angle of 0xFFF	–	95	–	%
<b>INCREMENTAL OUTPUT SPECIFICATIONS</b>						
ABI and UVW Output Angular Hysteresis [6]	$\text{hys}_{\text{ANG}}$	Programmable	0	–	1.38	degrees
<b>MANCHESTER INTERFACE SPECIFICATIONS</b>						
Manchester High Voltage [6]	$V_{\text{MAN}(\text{H})}$	Applied to VCC line	7.3	8	$V_{\text{CC}(\text{max})}$	V
Manchester Low Voltage [6]	$V_{\text{MAN}(\text{L})}$	Applied to VCC line	$V_{\text{CC}(\text{min})}$	5	5.7	V
Manchester Bitrate [6]	$f_{\text{MAN}}$	Line state changes once or twice per bit; maximum speed is usually limited by VCC line capacitance	2.2	–	100	kbit/s
<b>BUILT-IN SELF TEST</b>						
Logic BIST Time	$t_{\text{LBIST}}$	Configurable to run on power-up or on user request	–	30	–	ms
Circular Vertical Hall Self-Test Time	$t_{\text{CVHST}}$	Configurable to run on power-up or on user request	–	30	–	ms
<b>MAGNETIC CHARACTERISTICS</b>						
Magnetic Field	B	Range of input field	–	–	1200	G

Continued on the next page...

**OPERATING CHARACTERISTICS (continued):** Valid over the full operating voltage and ambient temperature ranges, unless otherwise noted

Characteristics	Symbol	Test Conditions	Min.	Typ. [1]	Max.	Unit [2]
<b>ANGLE CHARACTERISTICS</b>						
Output [7]	RES <sub>ANGLE</sub>	Both 12 and 15-bit angle values are available via SPI	–	12/15	–	bit
Angle Refresh Rate [8]	t <sub>ANG</sub>	No averaging	–	1.0	–	μs
Response Time [6]	t <sub>RESPONSE</sub>	Angular latency; valid for ABI or UVW interface	–	10	–	μs
Angle Error [9]	ERR <sub>ANG</sub>	T <sub>A</sub> = 25°C, ideal magnet alignment, B = 300 G, target rpm = 0	–1	±0.4	1	degrees
		T <sub>A</sub> = 150°C, ideal magnet alignment, B = 300 G, target rpm = 0	–1.3	±0.7	1.3	degrees
Temperature Drift	ANGLE <sub>DRIFT</sub>	T <sub>A</sub> = 150°C, B = 300 G, angle change from 25°C	–1.4	–	1.4	degrees
		T <sub>A</sub> = –40°C, B = 300 G, angle change from 25°C	–	0.9	–	degrees
Angle Noise [10][11]	N <sub>ANG</sub>	T <sub>A</sub> = 25°C, B = 300 G, no internal filtering, target rpm = 0, 3 sigma noise	–	±0.22	–	degrees
		T <sub>A</sub> = 150°C, B = 300 G, no internal filtering, target rpm = 0, 3 sigma noise	–	±0.28	–	degrees
Effective Resolution [12]		B = 300 G, T <sub>A</sub> = 25°C	–	12.47	–	bits
Angle Drift Over Lifetime [13]	ANGLE <sub>Drift_Life</sub>	B = 300 G, average maximum drift observed following AEC-Q100 qualification testing	–	0.5	–	degrees

[1] Typical data is at T<sub>A</sub> = 25°C and V<sub>CC</sub> = 5 V, and it is for design estimates only.

[2] 1 G (gauss) = 0.1 mT (millitesla).

[3] At power-on, a die will not respond to commands until V<sub>CC</sub> rises above V<sub>PORHI</sub>. After that, the die will perform and respond normally until V<sub>CC</sub> drops below V<sub>PORLOW</sub>.

[4] During the power-on phase, the AAS33001 SPI transactions are not guaranteed.

[5] The output voltage and current specifications are to aid in PCB design. The pin is not intended to drive any external circuitry. The specifications indicate the peak capacitor charging and discharging currents to be expected during normal operation.

[6] Parameter is not guaranteed at final test. Determined by design.

[7] RES<sub>ANGLE</sub> represents the number of bits of data available for reading from the die registers.

[8] The rate at which a new angle reading will be ready.

[9] Error value as measured at Allegro final test before any on-chip linearization is applied. Actual raw angle error performance in application can vary with multiple factors (e.g. magnet to sensor alignment, etc). Using the on-chip linearization features of the AAS33001 can significantly reduce these errors.

[10] Error and noise values are with no further signal processing. Angle Noise can be reduced with internal filtering and slower Angle Refresh Rate value.

[11] This value represents 3-sigma or three times the standard deviation of the measured samples.

[12] Effective Resolution is calculated using the formula below:

$$\log_2(360) - \log_2\left(\frac{1}{n} \sum_{i=1}^n \sigma_i\right)$$

where  $\sigma$  is the Standard Deviation based on thirty measurements taken at each of the 32 angular positions,  $i = 11.25, 22.5, \dots, 360$ .

[13] Maximum observed angle drift following AEC-Q100 stress was 1.4 degrees.

### FUNCTIONAL DESCRIPTION

#### Overview

The AAS33001 is a rotary position Hall-sensor-based device. It incorporates one or two electrically independent Hall sensor dies in the same surface-mount package to provide solid-state consistency and reliability, and to support a wide variety of automotive applications. Each Hall-sensor-based die measures the direction of the magnetic field vector through 360° in the x-y plane (parallel to the branded face of the device) and computes an angle measurement based on the actual physical reading, as well as any internal parameters that have been set by the user. The output of each die is used by the host microcontroller to provide a single channel of target data.

This device is an advanced, programmable system-on-chip (SoC). Each integrated circuit includes a circular vertical Hall (CVH) analog front end, a high-speed sampling A-to-D converter, digital filtering, digital signal processing, a digital control SPI interface, motor commutation outputs (UVW), and encoder outputs (A, B, I).

Advanced offset, gain, and linearization adjustment options are available in the AAS33001. These options can be configured in onboard EEPROM, providing a wide range of sensing solutions in the same device.

#### Angle Measurement

The AAS33001 can monitor the angular position of a rotating magnet at speeds ranging from 0 to more than 15,000 rpm. The AAS33001 has a typical output refresh rate of 1  $\mu$ s.

Readout in SPI is possible with 12-bit resolution, with error flags included in the same word, or in 15-bit resolution without included error flags. Reading out the angle takes 16 SPI clock cycles. See SPI Interface section for details on SPI usage.

PWM output is always resolved to a 12-bit angle resolution.

ABI/UVW resolution can be set to the level desired by the customer.

The sensor readout is processed and linearized in various steps. These are detailed in Figure 3.

#### System Level Timing

Internal registers are updated with a new angle value every  $t_{ANG}$ . Due to signal path delay, the angle is  $t_{RESPONSE}$  old at each update. In other words,  $t_{RESPONSE}$  is the delay from time of magnet sampling until generation of a processed angle value. The streaming protocols ABI and Uvw, which require no external trigger, will

update every  $t_{ANG}$  (if an angle change has occurred). SPI, which is asynchronously clocked, results in a varying latency depending on sampling frequency and SCLK speed. The values which are presented to the user are copied from the data path to the output registers between 0 and 125 ns after the SPI falling chip select edge. The first bit never contains data. If the SPI clock is 10 MHz, the data will be clocked out after 1.6  $\mu$ s. As the data were sampled in at the first clock edge at an age of maximum  $t_{RESPONSE}$ , their age after the SPI transaction has finished will be between 1.6 and  $1.6 + t_{RESPONSE}$   $\mu$ s.

Figure 2 shows the update rate and the signal delay of the different angle output paths depending on the sensor settings.

The value of the “angle\_zcd” register is updated approximately every 32  $\mu$ s. The value of the register “gauss” is update approximately every 128  $\mu$ s.

#### Power-Up

Upon applying power to the AAS33001, the device automatically runs through an initialization routine. The purpose of this initialization is to ensure that the device comes up in the same predictable operating condition every power cycle. This initialization routine takes a finite amount of time to complete, which is referred to as Power-On Time,  $t_{PO}$ . Regardless of the state of the device before a power cycle, the device will repower with EEPROM shadow bits copied from the EEPROM anew, and serial registers in their default states. For example, on every power-up, the device will power with the “zero\_offset” that was stored in the EEPROM. The extended write access field “write\_adr” will be set back to its default value, zero.

#### PWM Output

The AAS33001 provides a pulse-width-modulated output with duty cycle proportional to measured angle. The PWM duty cycle is clamped at 5% and 95% DC for diagnostic purposes. 5% DC corresponds to 0 degrees of angle; 95% DC corresponds to 360° of angle. The 0% and 100% (pulled low and pulled high) states are reserved for error condition notifications. The rising edges of the output are always at the same points in time, while the falling edge moves from 5% to 95% over angles of 0 to 360 degrees.

In case of errors, the setting “peo” = 1 will make errors affect the PWM pin. The setting “pes” = 0 will tristate the PWM pin, while with setting “pes” = 1, the output frequency will be halved, and the outputs will be fixed to the levels in Table 1.

**Table 1: PWM Output Errors**

Error	Priority	Duty Cycle %	Description / Persistence
WDE	1 (highest)	5	Watchdog error. Permanent error until restart.
OFE	2	10.625	Oscillator frequency watchdog error.
STF	3	16.25	Self-test failure. Permanent error until restart.
PLK	4	21.875	PLL not locked. Persists until PLL locks.
ZIE	5	27.5	Zero-crossing integrity error. Persists as long as the issue exists.
AVG	6	33.125	Angle averaging error. Outputs once then clears.
UV	7	38.75	Undervoltage (UVA and/or UVCC dependent on serial error masks). Persists until no unmasked undervoltage.
MSL	8	44.375	Persists until field strength higher than low threshold.
ESE	9	50	EEPROM correctable error. Outputs once, then clears.
SAT	10	55.625	Saturation error. Persists as long as the issue exists.
MSH	11	61.25	Persists until field strength lower than high threshold.
TR	12 (lowest)	66.875	Persists until temperature within range.

The duty cycle of the pin can be configured using the “pwm\_band” and the “pwm\_freq” fields, yielding the frequencies shown in Table 2.

**Table 2: PWM Frequency Table (Hz)**

		“pwm_band”							
		0	1	2	3	4	5	6	7
“pwm_freq”	0	3125	2778	2273	1667	1087	641	352	185
	1	3101	2740	2222	1613	1042	610	333	175
	2	3077	2703	2174	1563	1000	581	316	166
	3	3053	2667	2128	1515	962	556	301	157
	4	3030	2632	2083	1471	926	532	287	150
	5	3008	2597	2041	1429	893	510	275	143
	6	2985	2564	2000	1389	862	490	263	137
	7	2963	2532	1961	1351	833	472	253	131
	8	2941	2500	1923	1316	806	455	243	126
	9	2920	2469	1887	1282	781	439	234	121
	10	2899	2439	1852	1250	758	424	225	116
	11	2878	2410	1818	1220	735	410	217	112
	12	2857	2381	1786	1190	714	397	210	108
	13	2837	2353	1754	1163	694	385	203	105
	14	2817	2326	1724	1136	676	373	197	101
15	2797	2299	1695	1111	658	362	191	98	

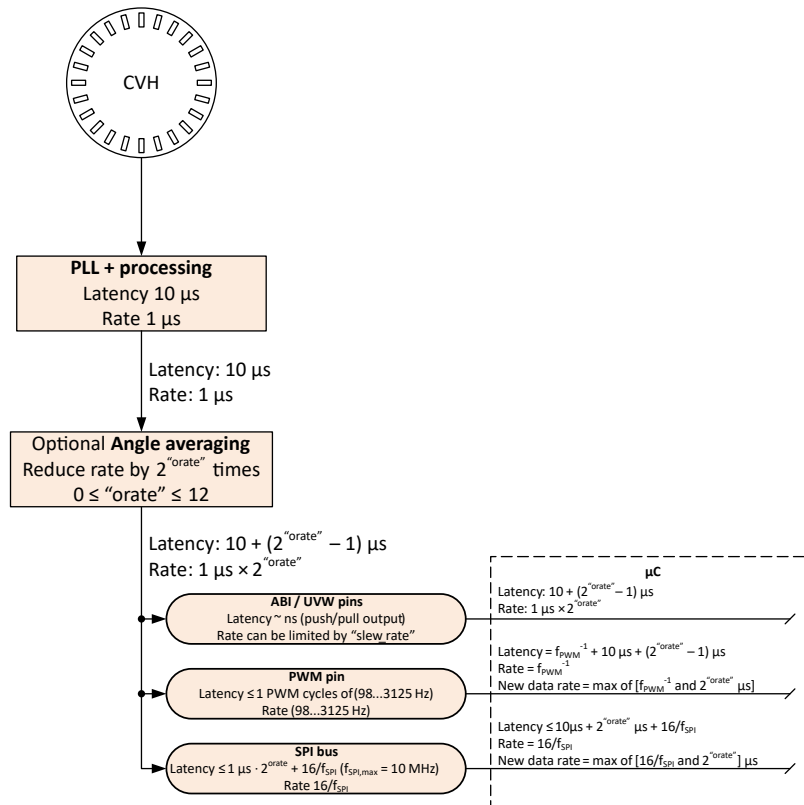

Figure 2: Signal Latency and Update Rates

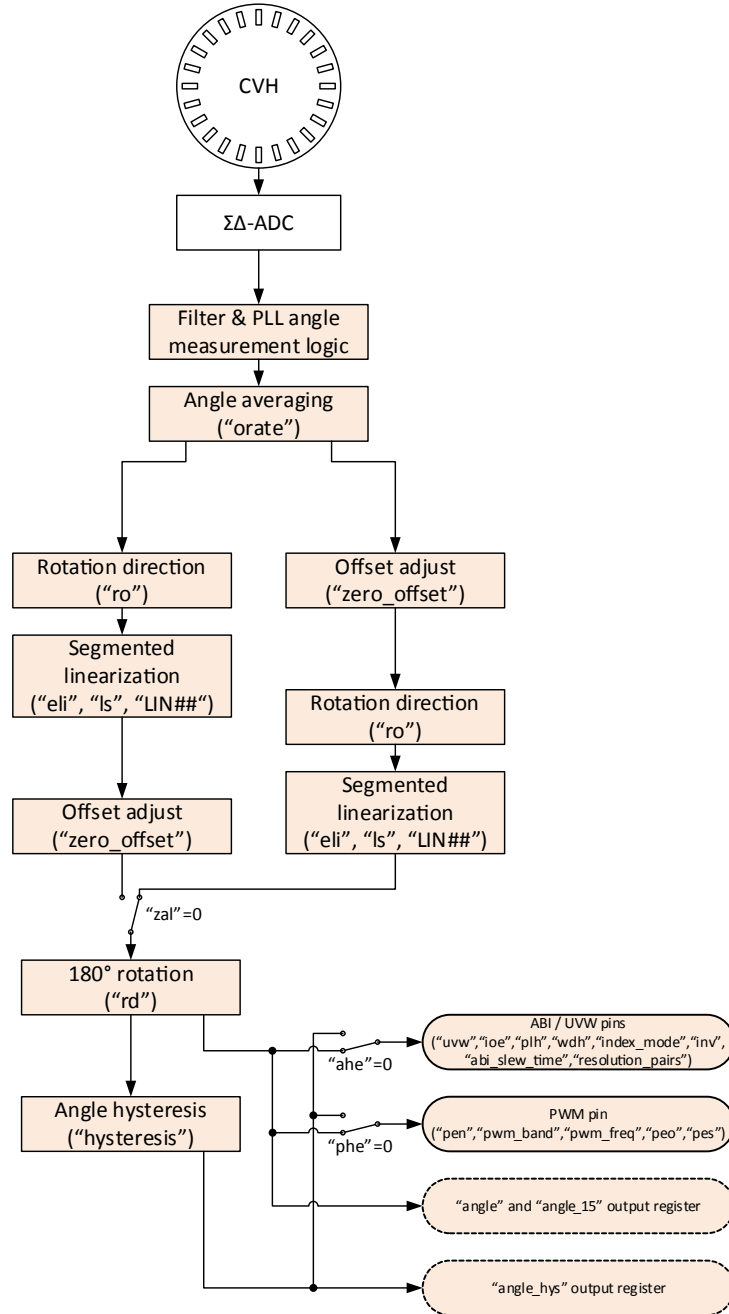

Figure 3: Angle data flow chart.  
Text in quotes (“”) denotes registers that affect their containing block.

### Linearization

The AAS33001 contains linearization functionality. Linearization allows for conversion of the initially sensor-measured magnetic field data into customer-desired linear output. This can be used to correct minor imperfections in the encoder signal, or to allow motor commutation in side-shaft measurement setups.

Linearization converts the electrical angles (the angle as measured by the sensor front end) into mechanical angles (the actual angle of the encoder signal).

To use the linearization feature, it is most convenient to use the Allegro AAS33001 Samples Programmer Graphical User Interface (GUI). It allows the user to measure points along the mechanical rotation, calculate all parameters that need to be written into the sensor, and writes these values into the sensor. To use this function, the user must be able to read and control the mechanical angle.

The sensor performs linearization by taking the measured electrical angles and, depending on the angle measured, subtracting a linearization coefficient stored in EEPROM. There are 32 of these linearization coefficients in the EEPROM. The angle value at a sensor angle reading of 0.00, 11.25, 22.50, ... 348.75 electrical degrees will be modified by the values in EEPROM fields LIN0, LIN1, LIN2, ... LIN31. The EEPROM LIN values are subtracted from the electrical sensor angles, as shown in Table 3.

The LIN fields are 12-bit signed values. Each LIN coefficient has a range of -2048...+2047 LSB that corresponds to a correction of the electrical angle by +22.50...-22.49 degrees (EEPROM field "ls" = 0) or by +45.00...-44.98 degrees (EEPROM field "ls" = 1). When the electrical angle is between of two of the linearization points, the sensor calculates the appropriate correction value for this angle by linear interpolation between the two coefficients next to the value. For example, if the sensor measures an angle of 5.625°, the output will be  $5.625 - (LIN0 + LIN1) / 2$ .

Figure 4 is an example showing a nonlinear curve that is corrected by the sensor. In this example, the values of LIN0, LIN1, LIN2, and LIN3 are negative numbers, while LIN4 is a positive number. The linearized output angle in the example is close to the mechanical angle, but not perfect. This was done on purpose to show a more realistic example.

The output delay of the AAS33001 is not affected by enabling or disabling linearization. If linearization is disabled, the EEPROM LIN fields can be used for other customer purposes.

Table 3: Linearization Coefficients

Electrical angle (°) measured by sensor	Correction value Written in EEPROM	Output angle Visible on sensor output
0.00	LIN0	Output = 0.00 – LIN0
11.25	LIN1	Output = 11.25 – LIN1
22.50	LIN2	Output = 22.50 – LIN2
33.75	LIN3	Output = 33.75 – LIN3
45.00	LIN4	Output = 45.00 – LIN4
56.25	LIN5	Output = 56.25 – LIN5
67.50	LIN6	Output = 67.50 – LIN6
78.75	LIN7	Output = 78.75 – LIN7
90.00	LIN8	Output = 90.00 – LIN8
101.25	LIN9	Output = 101.25 – LIN9
112.50	LIN10	Output = 112.50 – LIN10
123.75	LIN11	Output = 123.75 – LIN11
135.00	LIN12	Output = 135.00 – LIN12
146.25	LIN13	Output = 146.25 – LIN13
157.50	LIN14	Output = 157.50 – LIN14
168.75	LIN15	Output = 168.75 – LIN15
180.00	LIN16	Output = 180.00 – LIN16
191.25	LIN17	Output = 191.25 – LIN17
202.50	LIN18	Output = 202.50 – LIN18
213.75	LIN19	Output = 213.75 – LIN19
225.00	LIN20	Output = 225.00 – LIN20
236.25	LIN21	Output = 236.25 – LIN21
247.50	LIN22	Output = 247.50 – LIN22
258.75	LIN23	Output = 258.75 – LIN23
270.00	LIN24	Output = 270.00 – LIN24
281.25	LIN25	Output = 281.25 – LIN25
292.50	LIN26	Output = 292.50 – LIN26
303.75	LIN27	Output = 303.75 – LIN27
315.00	LIN28	Output = 315.00 – LIN28
326.25	LIN29	Output = 326.25 – LIN29
337.50	LIN30	Output = 337.50 – LIN30
348.75	LIN31	Output = 348.75 – LIN31

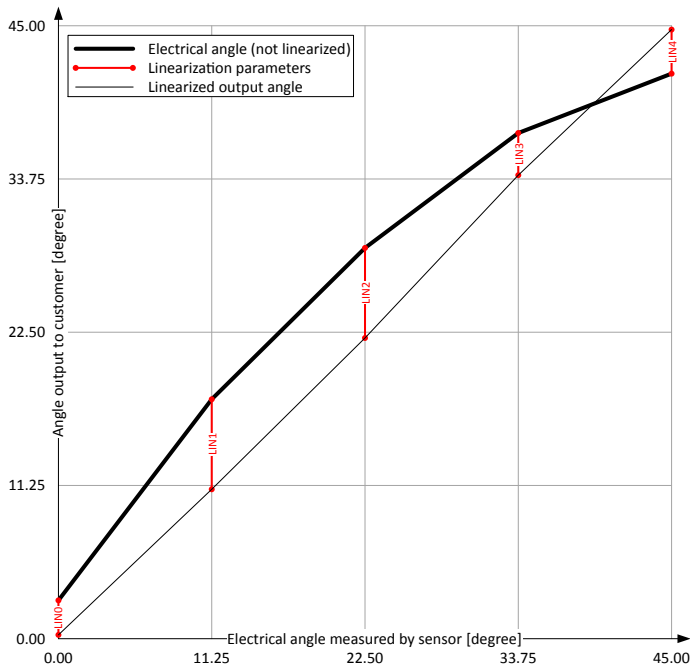

Figure 4: Linearization Example

### Incremental Output Interface (ABI)

The AAS33001 offers an incremental output mode in the form of quadrature A/B and Index outputs to emulate an optical or mechanical encoder. The A and B signals toggle with a 50% duty cycle (relative to angular distance, not necessarily time) at a frequency of  $2N$  cycles per magnetic revolution, giving a cycle resolution of  $(360 / 2^N)$  degrees per cycle. B is offset from A by  $1/4$  of the cycle period. The “I” signal is an index pulse that occurs once per revolution to mark the zero (0) angle position. One revolution is shown in Figure 5.

Since A and B are offset by  $1/4$  of a cycle, they are in quadrature and together have four unique states per cycle. Each state represents  $R = [360 / (4 \times 2^N)]$  degrees of the full revolution. This angular distance is the quadrature resolution of the encoder. The order in which the states change, or the order of the edge transitions from A to B, allow the direction of rotation to be determined. If a given B edge (rising/falling) precedes the following A edge, the angle is increasing from the perspective of the electrical (sensor) angle and the angle position should be incremented by the quadrature resolution (R) at each state transition. Conversely, if a given A edge precedes the following B edge, the angle is decreasing from the perspective of the electrical (sensor) angle and the angle position should be decremented by the quadrature resolution (R) at each state transition. The angle position accumulator wraps each revolution back to 0. The quadrature states are designated as Q1 through Q4 in the following diagrams, and are defined as follows:

State Name	A	B
Q1	0	0
Q2	0	1
Q3	1	1
Q4	1	0

Note that the A/B progression is a grey coding sequence where only one signal transitions at a time. The state progression must be as follows to be valid:

Increasing angle: Q1 → Q2 → Q3 → Q4 → Q1 → Q2 → Q3 → Q4

Decreasing angle: Q4 → Q3 → Q2 → Q1 → Q4 → Q3 → Q2 → Q1

The duration of one cycle is referred to as 360 electrical degrees, or 360e. One half of a cycle is therefore 180e and one quarter of a cycle (one quadrature state, or R degrees) is 90e. This is the

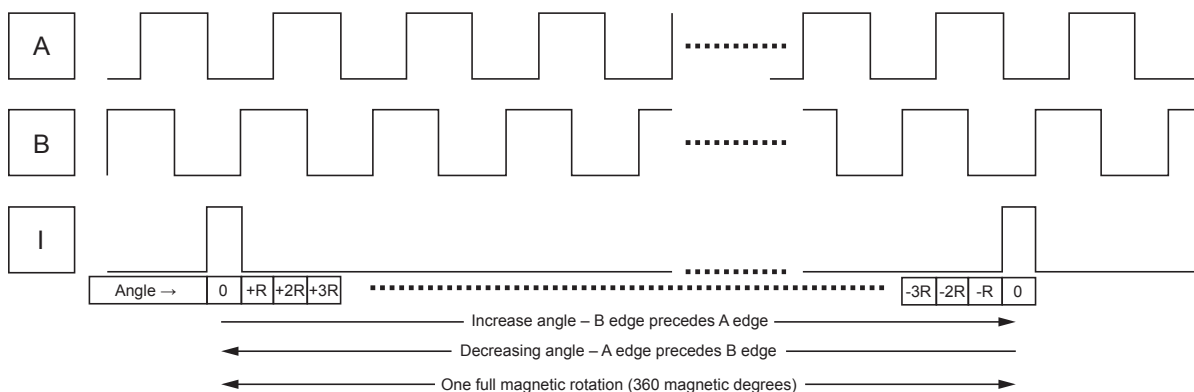
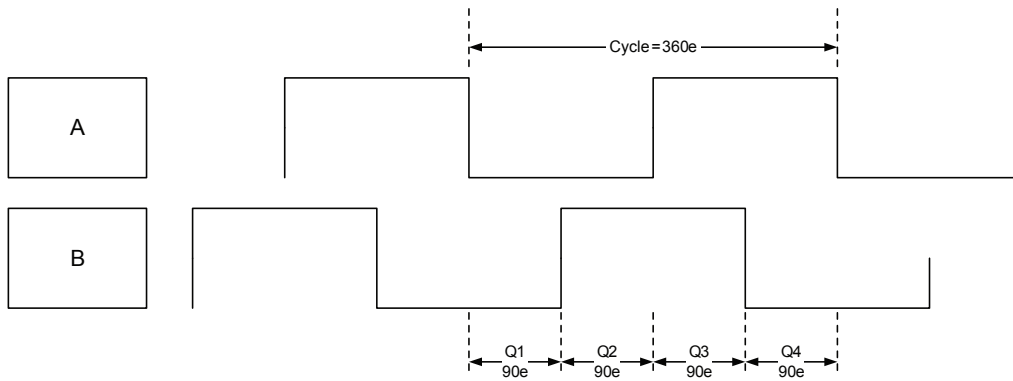

Figure 5: One Full Revolution

terminology used to express variance from perfect signal behavior. Ideally, the A and B cycle would be as shown below for a constant velocity (see Figure 6).

In reality, the edge rate of the A and B signals, and the switching threshold of the receiver I/Os, will affect the quadrature periods (see Figure 7).



**Figure 6: Electrical Cycle**

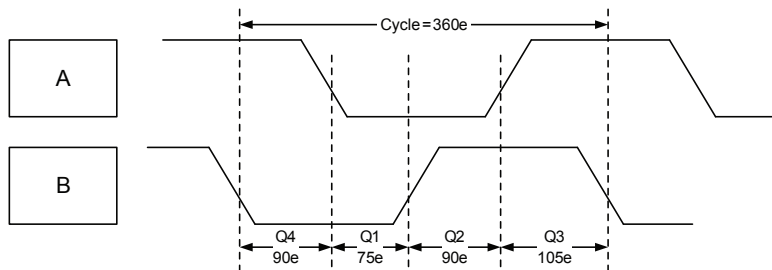

**Figure 7: Electrical Cycle**

### RESOLUTION

The AAS33001 supports the following ABI output resolutions.

This is set via the resolution\_pairs field in EEPROM.

**Table 4: ABI Output Resolution**

EEPROM Resolution Field	Cycle Resolution (Bits = N)	Quadrature Resolution (Bits = 4 × N)	Cycles per Revolution (A or B)	Quadrature States per Revolution	Cycle Resolution (Degrees)	Quadrature Resolution (R) (Degrees)
0	Factory Use Only					
1	Factory Use Only					
2	Factory Use Only					
3	11	13	2048	8192	0.176	0.044
4	10	12	1024	4096	0.352	0.088
5	9	11	512	2048	0.703	0.176
6	8	10	256	1024	1.406	0.352
7	7	9	128	512	2.813	0.703
8	6	8	64	256	5.625	1.406
9	5	7	32	128	11.250	2.813
10	4	6	16	64	22.500	5.625
11	3	5	8	32	45.000	11.250
12	2	4	4	16	90.000	22.5
13	1	3	2	8	180.0	45.0
14	0	2	1	4	360.0	90.0
15	n/a	n/a	n/a	n/a	n/a	n/a

### SLEW RATE LIMITING

Slew rate limiting is enabled when the ABI.abi\_slew\_time field is non-zero. This option separates the sample update rate from the ABI output rate, and can be used to control two circumstances:

- The angle sample does not monotonically increase or decrease at the quadrature resolution, thereby “skipping” one or more quadrature states. In this case, the slew rate limiting logic transitions the ABI signals in the required valid sequence, at the slew rate, until the ABI output “catches up” with the angle samples, at which point the

normal sample rate output resumes. This skipping will most likely occur either at very low velocities, if the noise is high, or at very high velocities when the angle changes more than the quadrature resolution in one angle sample period.

- The ABI receiver at the host end cannot reliably detect edge transitions that are spaced at the sample rate of  $1 \mu\text{s}$ . The slew limit time can be set greater than the nominal angle sample update period, providing the velocity of the angle rotation would not on average require ABI transitions greater than the angle sample rate.

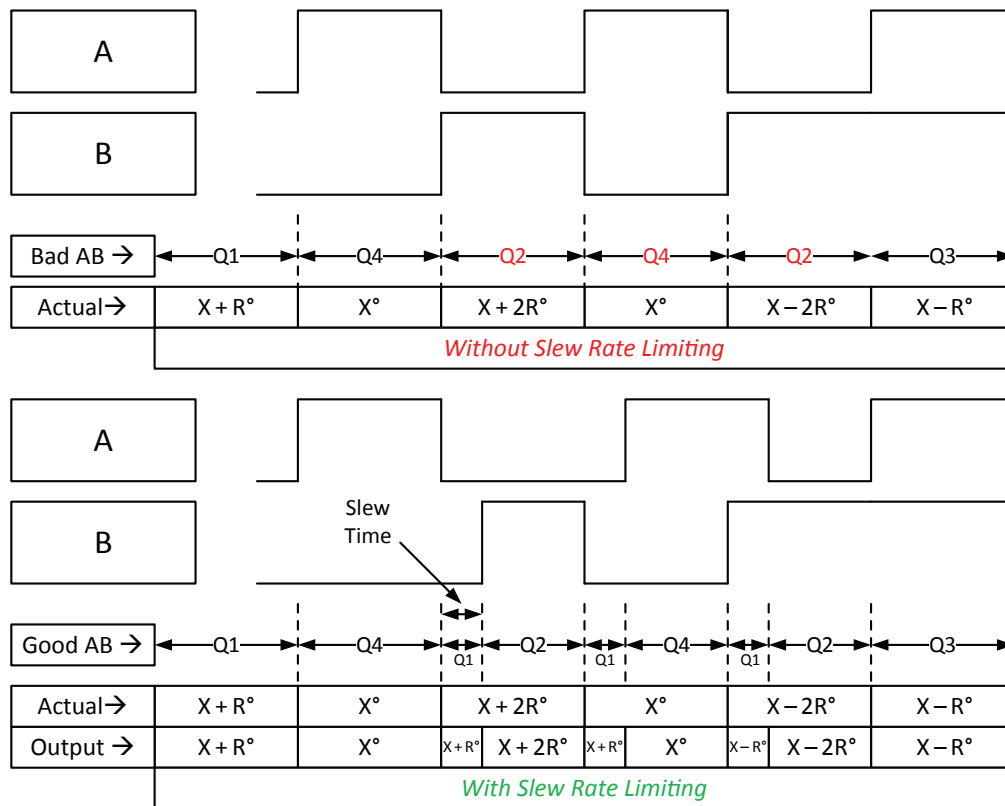

Figure 8: Slew Rate Limiting

### INDEX PULSE

The index pulse I (or Z in some descriptions) marks the absolute zero (0) position of the encoder. Under rotation, this allows the receiver to synchronize to a known mechanical/magnetic position, and then use the incremental A/B signals to keep track of the absolute position. To support a range of ABI receivers, the 'I' pulse has four widths, defined in Figure 9.

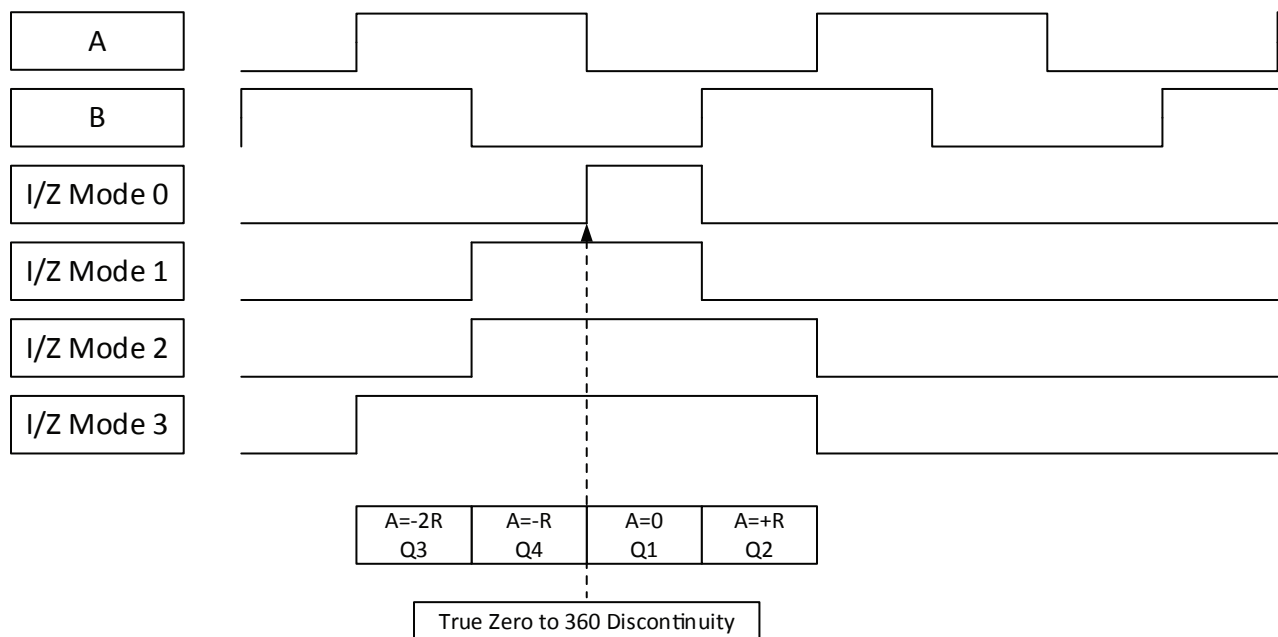

Figure 9: Index Pulse

### Brushless DC Motor Output (UVW)

The AAS33001 offers U, V, and W signals for stator commutation of brushless DC (BLDC) motors. The device is mode-selectable for 1 to 16 pole-pairs. The BLDC signals (U, V, and W) are generated based on the quantity of pole-pairs and on angle information from the angle sensor. The U, V, and W outputs switch when

the measured mechanical angle crosses the value where a change should occur. If hysteresis is used, then the output update method is different. The output behavior when hysteresis is enabled is described in the “Angle Hysteresis” section. Figure 10 and Figure 11 below show the UVW waveforms for three and five pole-pair BLDC motors.

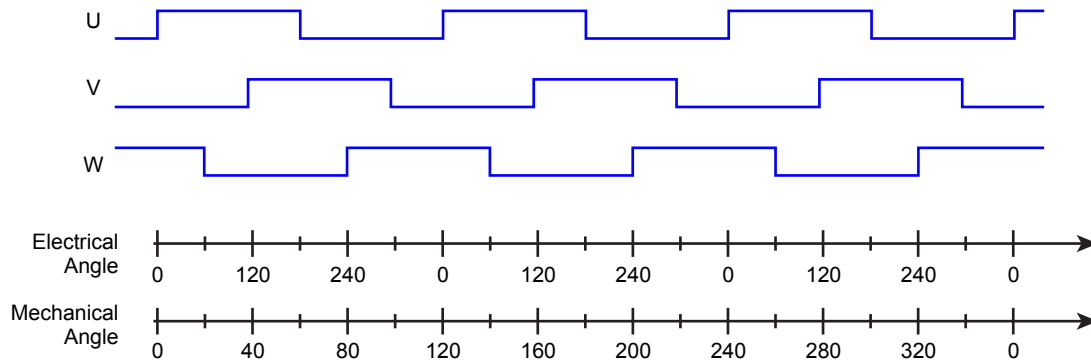

Figure 10: U, V, W Outputs for Three Pole-Pair BLDC Motor

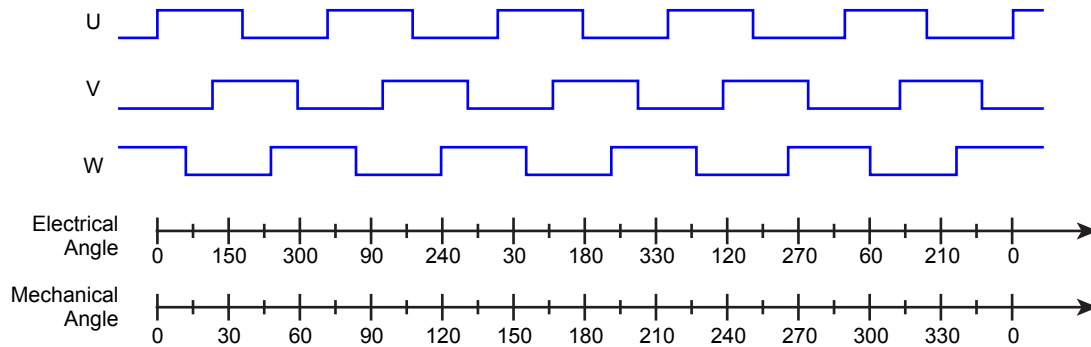

Figure 11: U, V, W Outputs for Five Pole-Pair BLDC Motor

Quantity of Poles ("resolution_pairs")	Quantity of Pole-Pairs	Conversion from Electrical Degrees to Mechanical Degrees	
		Electrical (°)	Mechanical (°)
0000	1	90	90
0001	2	90	45
0010	3	90	30
0011	4	90	22.5
0100	5	90	18
0101	6	90	15
0110	7	90	12.857...
0111	8	90	11.25
1000	9	90	10
1001	10	90	9
1010	11	90	8.1818...
1011	12	90	7.5
1100	13	90	6.9231...
1101	14	90	6.4286...
1110	15	90	6
1111	16	90	5.625

### ABI Behavior at Power-Up

At power-up, the AAS33001 ABI interface communicates the current position. This means that reading the angle through the PWM output is not needed to find the current position when using the ABI interface. The behavior at start-up is the following:

- During  $t_{PO}$ , the state of the interface is undefined
- During a delay phase, the output will display a 0° angle. With default settings, the 0° angle is indicated by A = B = low and I = high.
- The interface will “catch up” with the actual measured angle by moving in positive or negative direction, whichever

is faster. The time for catching up is at most:

$$t_{SETTLE(MAX)} = \frac{180^\circ}{R} \times ABI\_slew\_time$$

with R = quadrature resolution.

- After catching up, with the output angle is completed, the sensor will operate normally.

If “ABI\_slew\_time” is set to 0, there is no “catch-up” phase. The output will jump to the final position immediately, e.g. with A = high and B = low. With “ABI\_slew\_time” set to 0, the user cannot determine the position at startup from the ABI interface.

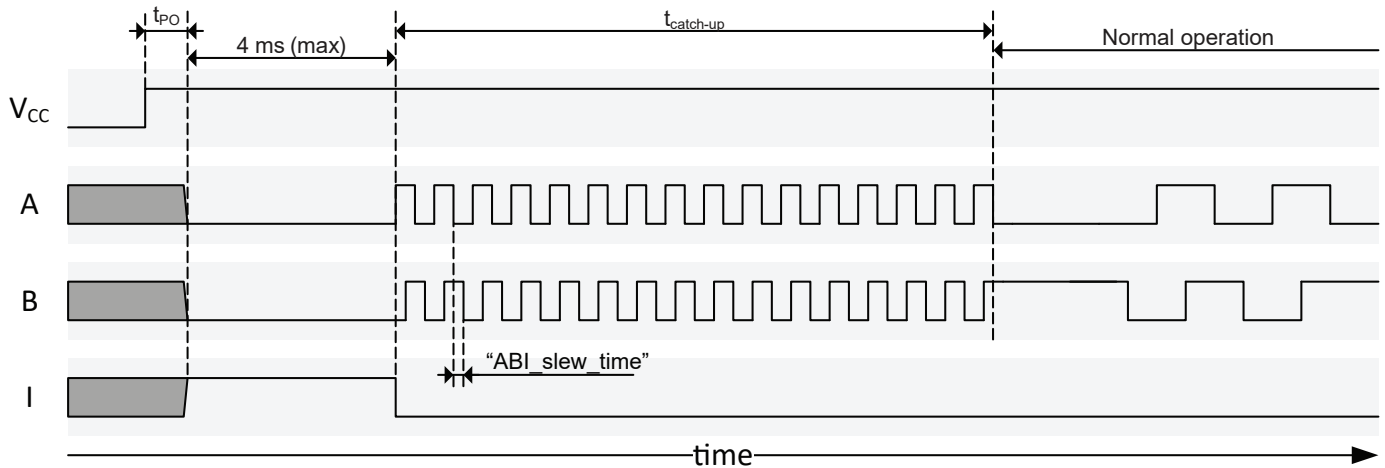

Figure 12: ABI Startup Behavior

## Angle Hysteresis

Hysteresis can be applied to the compensated angle to moderate jitter in the angle output due to noise or mechanical vibration. In the AAS33001, the hysteresis field (ANG.hysteresis) defines the width of an angle window at 14-bit resolution. Mathematically, the width of this window is:

$$ANG.hysteresis \times (360 / 16384) \text{ degrees}$$

giving a range of 0 to 1.384 degrees.

The hysteresis-compensated angle can be routed to the ABI or UVW interface by setting the ABI.ahe bit to 1. On the SPI or Manchester interface, the hysteresis-compensated angle can be read via an alternate register (HANG.angle\_hys) at 12-bit resolution.

The effect of the hysteresis is shown in Figure 13. The current angle position as measured by the sensor is at the “head” of the hysteresis window. As long as the sensor (electrical) angle advances in the same direction of rotation, the output angle will be the sensor angle, minimizing latency. If the sensor angle reverses direction, the output angle is held static until the sensor

angle exits the hysteresis window in either direction. If the exit is in the opposite direction of rotation where the “head” was, the head flips to the opposite end of the hysteresis window and that becomes the new reference direction. The current direction of rotation, or “head” for the purposes of hysteresis, is viewable via the STA.rot bit, where 0 is increasing angle direction and 1 is in decreasing angle direction.

This behavior has the following consequences:

1. If the hysteresis window is greater than the output resolution, the output angle will skip consecutive incremental steps. If the hysteresis-compensated angle is selected for the ABI output, this would result in an integrity failure due to skipped quadrature states. To avoid this, it is recommended that the slew rate limiting be enabled on the ABI interface if hysteresis is used.
2. If there is jitter due to noise or mechanical vibration, especially at a static angle position or very slow rotation, the angle will tend to bias to one side of the window, depending on the direction of rotation as the angular velocity approaches zero (i.e., towards the current “head”) rather than to the average position of the jitter.

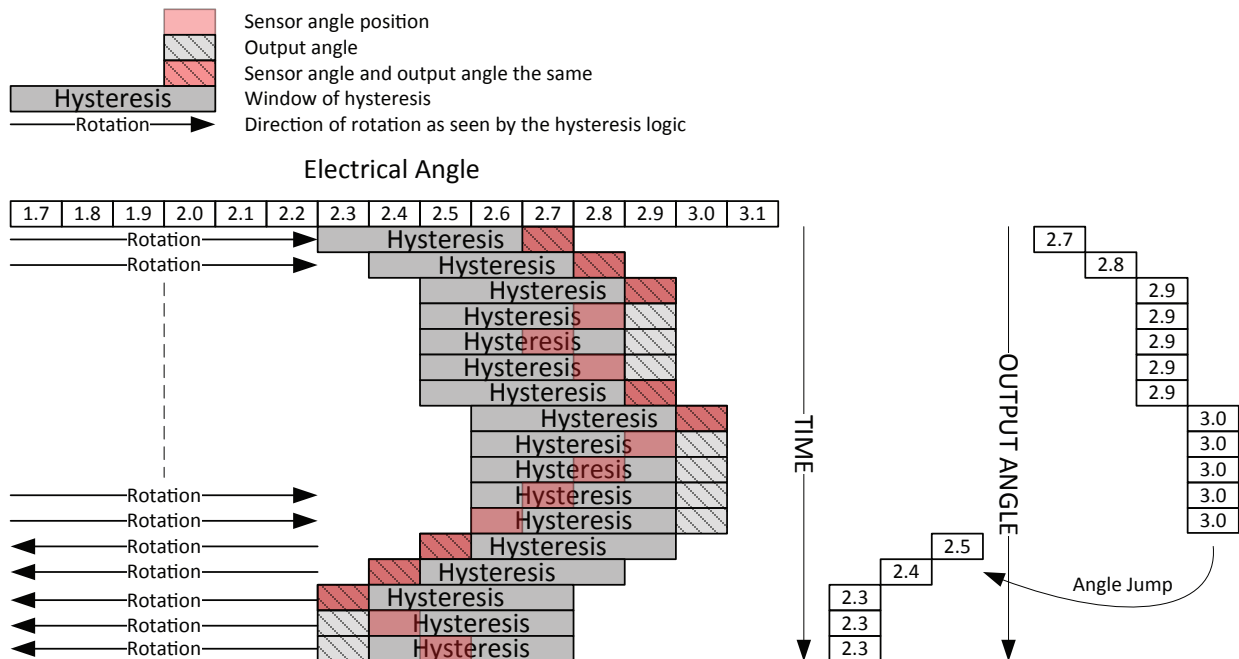

**Figure 13: Effect of Hysteresis**

Note: The rotation direction resets to 0, or increasing angle direction. At power-up or after LBIST, the hysteresis window will always be behind the initial angle position, so if hysteresis is enabled, a decreasing angle direction of rotation will not register until the hysteresis window is past.

### DEVICE PROGRAMMING INTERFACE

The AAS33001 can be programmed in two ways:

- Using the *SPI interface* for input and output, while supplying the VCC pin with normal operating voltage
- Using a *Manchester protocol* on the supply pin for input, and the PWM pin for output.

The AAS33001 does not require special supply voltages to write to the EEPROM.

All setting fields and all data fields of the sensor can be read and written using both protocols. If EEPROM locking is used (detailed in EEPROM lock section), then write access using either of the protocols will be prevented.

A separate setting to completely disable the Manchester interface is available in the dm field of the EEPROM. Using this setting will cause the sensor to ignore any commands entered using Manchester protocol. The SPI interface will not be disabled by disabling the Manchester interface.

#### Interface Structure

The AAS33001 consists of two memory blocks. The primary serial interface registers are used for direct writes and reads by the host controller for frequently required information (for example, angle data, warning flags, field strength, and temperature). All forms of communication (even to the extended loca-

tions) operate through the primary registers, whether it be via SPI or Manchester.

The primary serial registers also provide a data and address location for accessing extended memory locations. Accessing these extended location is done in an indirect fashion: the controller writes into the primary interface to give a command to the sensor to access the extended locations. The read/write is executed and the result is again presented in the primary interface.

This concept is shown in Figure 14 below.

For writing extended locations, the primary interface offers extended write address, data, and control registers. Refer to the section “Write Transaction to EEPROM and Other Extended Locations” for details on their usage.

For reading extended locations, the primary interface offers extended read address, data, and control registers. Refer to the section “Read Transaction from EEPROM and other Extended Locations” for details on their usage.

EEPROM writing requires additional procedures. For more information on EEPROM and shadow memory read and write access, see “EEPROM and Shadow Memory Usage” section.

The primary serial interface can be accessed using the SPI and using the Manchester interface. These two interfaces are detailed in the sections below.

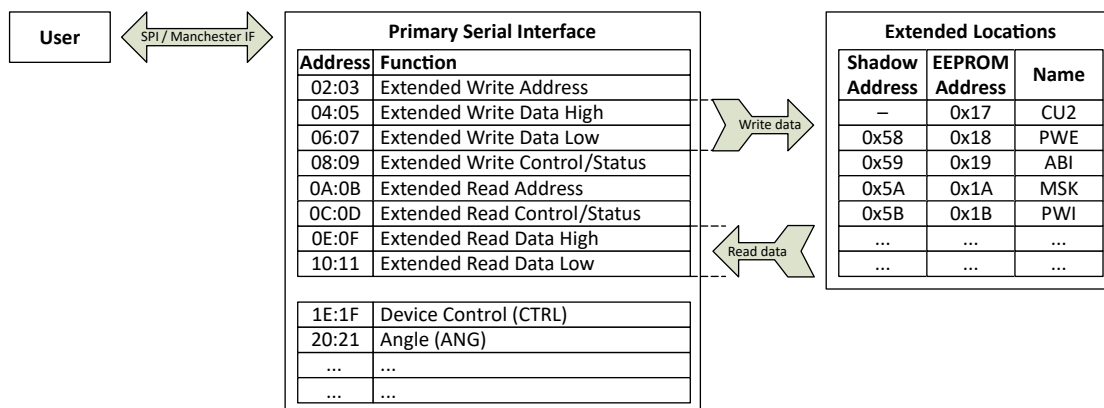

Figure 14: Serial Registers allow access to extended memory (EEPROM and Shadow)

### SPI Interface

The AAS33001 provides a full-duplex 4-pin SPI interface for each die, using SPI mode 3 (CPHA = 1, CPOL = 1). All programming can be done using this interface, but all programming can also be done using the Manchester interface.

If the SPI interface is not used, do not leave the chip select line floating but instead follow the recommendations in the “Typical SPI and ABI/UVW Applications” section.

The sensor responds to commands received on the MOSI (Master-Out Slave-In), SCLK (Serial Clock), and CSB (Chip Select) pins, and outputs data on the MISO (Master-In Slave-Out) pin. All three input pins are 3.3 V and 5 V SPI compatible, with threshold values determined by factory EEPROM settings. MISO output voltage level will conform to 3.3 V or 5 V SPI levels, based on factory settings. Regular part are shipped with 3.3 V interface. Contact Allegro for ordering options of the 5 V variant.

The setup for communication using the SPI interface is given in Figure 15 below:

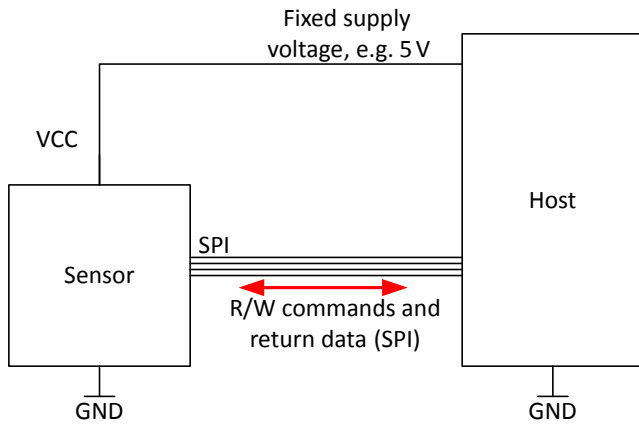

Figure 15: Programming Connections for SPI Interface

### TIMING

The interface timing parameters from the specification table are defined in Figure 16 and Figure 17 below.

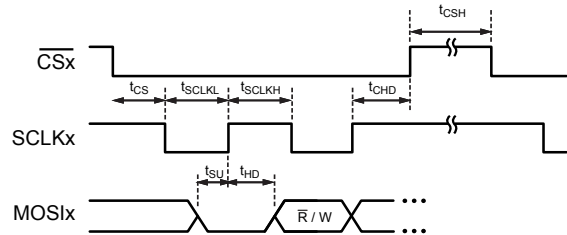

Figure 16: SPI Interface Timings Input

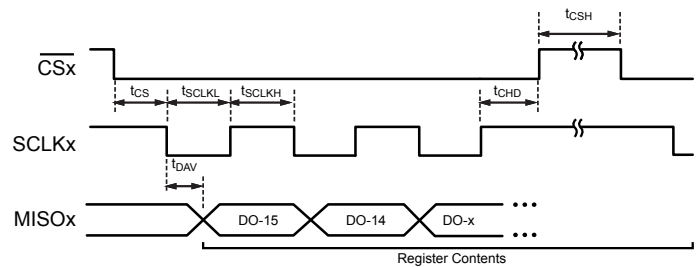
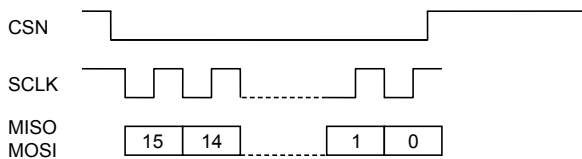

Figure 17: SPI Interface Timings Output

### MESSAGE FRAME SIZE

The SPI interface requires either 16, 17, or 20-bit packet lengths. An extended 20-bit SPI packet allows 4 bits of CRC to accompany every data packet. A 17-bit packet is only allowed if the EEPROM/Shadow bit “s17” is set to 1.



**Figure 18: 16-Bit SPI Frame**

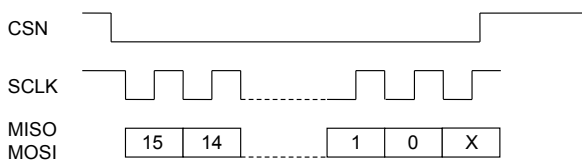

**Figure 19: 17-Bit SPI Frame**

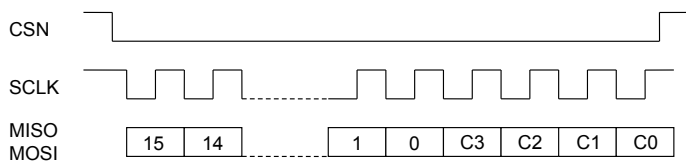

**Figure 20: 20-Bit SPI Frame**

If more clock pulses than expected were detected by the sensor in an SPI transaction, the interface warning “warn.ier” will activate. This warning will not activate on clean SPI transactions with 16 or 20 bit, or with clean 17-bit transactions when “s17” is enabled.

The purpose of the 17-bit SPI option is to allow delayed reading of the MISO line by the host. Some hosts allow sampling of data from the slave not on the rising edge, but on the next falling edge of SCLK. This way, in case of long interface delays caused by large line capacitance or very long cables, the permissible clock speed can be increased. However, a 17th falling edge is required to read the 16th bit coming from the sensor. For the sensor to not display an error when this 17th clock is found, the bit “s17” must be set.

### WRITE CYCLE

Write cycles consist of a 1-bit low, a 1-bit R/W (write = high), 6 address bits (corresponding to the primary serial register), 8 data bits, and 4 optional CRC bits. To write a full 16-bit serial register, two write commands are required (even and odd byte addresses). MOSI bits are clocked in on the rising edge of the Master-generated SCLK signal.

### READ CYCLE

Reading data always involves at least two SPI frames. In the first frame, the read command is sent, while in the second frame, the result from the first read is received. While receiving data from the last read command, it is possible to send another read command (duplexed read). This way, every frame except the first one contains data from the sensor. This is useful for very fast reading of angle information.

When receiving the last frame, the host can transmit a command with MOSI set to all zeros. This represents a read command from register 0x00 and will not change the state of the sensor. Reading from register 0x00 will output the value 0x0000.

In frames where no previous read command was sent, the MISO data output should be ignored.

Because an SPI read command can transmit 16 data bits at one time, and the primary serial registers are built from one even and one odd byte, the entire 16-bit contents of one serial register may be transmitted with one SPI frame. This is accomplished by providing an even serial address value. If an odd value address is sent, only the contents of the single byte will be returned, with

the eight most significant bits within the SPI packet set to zero. Example: To read all 16 bits of the error register (0x24:0x25), an SPI read request using address 0x24 should be sent. If only the 8 LSBs are desired, the address 0x25 should be used. Figure 21 shows examples of both an SPI write and an SPI read request, using a 16-bit SPI message frame.

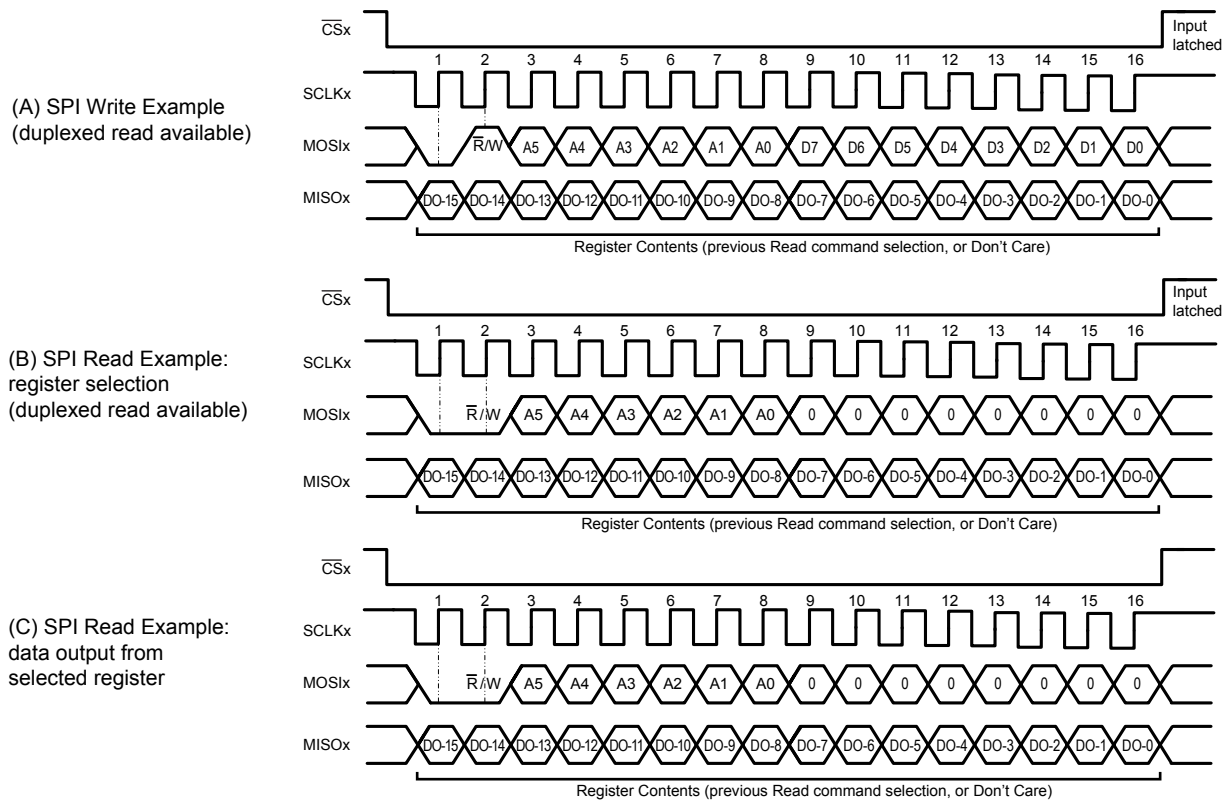

**Figure 21: SPI Read and Write Pulse Sequences**

### CRC

If the user want to check the data coming from the sensor, it is possible to use 20-bit SPI frames. Without additional setting required, a 4-bit CRC is automatically generated and placed on the MISO line if more than 16 bits are read from the sensor.

The four additional CRC bits on the MOSI line coming from the host are ignored by the sensor, unless the “PWI.sc” bit is set within EEPROM. When the incoming CRC check is enabled, an incoming SPI packet with an incorrect CRC will be discarded, and the CRC error flag set in serial register “warn.crc”.

The CRC is based on the polynomial  $x^4 + x + 1$  with the linear feedback shift register preset to all 1s. The 16-bit packet is shifted through from bit 15 (MSB) to bit 0 (LSB). The CRC logic is shown in Figure 22. Data are fed into the CRC logic with MSB first. Output is sent as C3-C2-C1-C0.

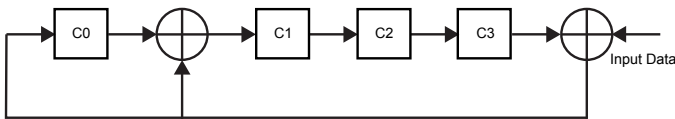

**Figure 22: SPI CRC**

The CRC output by the sensor on the MISO pin will always be calculated correctly. The CRC from the host on the MOSI pin must be correct if the CRC enable bit PWI.sc in the EEPROM was set.

Note: If the ERD (extended read data) register is read before the “ERCS.ERD” bit indicates a read has completed, there is a possibility of a CRC error, as the data could change during the read. Do not read the ERD register until it is known to be stable based on the done bit indication or waiting sufficient time.

The CRC can be calculated with the following C code:

```

/*
 * CalculateCRC
 *
 * Take the 16-bit input and generate a 4-bit CRC
 * Polynomial = x^4 + x + 1
 * LFSR preset to all 1's
 */
uint8_t CalculateCRC(uint16_t input)
{
    bool CRC0 = true;
    bool CRC1 = true;
    bool CRC2 = true;
    bool CRC3 = true;
    int i;
    bool DoInvert;
    uint16_t mask = 0x8000;

    for (i = 0; i < 16; ++i)
    {
        DoInvert = ((input & mask) != 0) ^ CRC3; // XOR
        required?

        CRC3 = CRC2;
        CRC2 = CRC1;
        CRC1 = CRC0 ^ DoInvert;
        CRC0 = DoInvert;
        mask >>= 1;
    }

    return (CRC3 ? 8U : 0U) + (CRC2 ? 4U : 0U) + (CRC1 ? 2U
: 0U) + (CRC0 ? 1U : 0U);
}

```

This code can be tested at <http://codepad.org/jPPW1CQ4>.

### Manchester Interface

To facilitate addressable device programming when using the unidirectional PWM output mode with no need for additional wiring, the AAS33001 incorporates a serial interface on the VCC line. All programming can be done using this interface, but all programming can also be done using the SPI interface.

This interface allows an external controller to read and write registers in the AAS33001 EEPROM and volatile memory. The device uses a point-to-point communication protocol, based on Manchester encoding per G.E. Thomas (a rising edge indicates a 0 and a falling edge indicates a 1), with address and data transmitted MSB first. The addressable Manchester code implementation uses the logic states of the CSN/MOSI pins to set address values for each die. In this way, individual communication with up to four AAS33001 dies is possible. Using a broadcast Manchester command, any die receiving the command will respond. To prevent any undesired programming of the AAS33001, the serial interface can be disabled by setting the Disable Manchester bit, “PWI.dm”, to 1. With this bit set, the sensor will ignore any Manchester input on VCC.

The setup for communication using the Manchester interface is given in Figure 23.

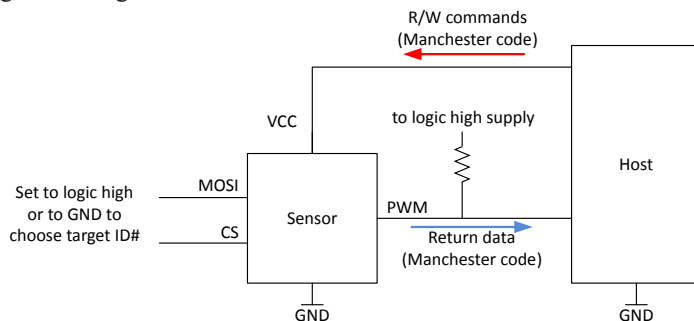

**Figure 23: Manchester Interface Programming Setup**

### CONCEPT OF MANCHESTER COMMUNICATION

The Manchester interface allows programming and readout with a minimal number of pins involved. This is beneficial for sensor subassemblies connected to wiring harnesses, because less connections are needed. The supply level is typically modulated between 5 and 8 volts ( $V_{MAN(H)}$  and  $V_{MAN(L)}$ ) to produce a “low” and “high” signal. In the absence of a clock signal, Manchester encoding is used, allowing the sensor to determine the bit rate that the host is using.

The master can freely choose any supported Manchester communication frequency for each transaction. The sensor will recognize the transaction speed used by the master and send the response at the same data rate.

As Manchester commands are sent on the supply line, the speed is usually limited by capacitances on the supply line. A reduction of the bit rate, or using a stronger line driver, can help to ensure stable communication.

If a correct read command was sent, the sensor responds to the master using the open-drain output on the PWM line. The high level will be determined by the PWM pull-up (usually 3.3 V or 5 V), and the low level will be close to GND. The PWM uses an open drain output, setting the logic levels to GND and logic level high (see Figure 23). A sufficient pull-up resistor (e.g. 4.7 k $\Omega$ ) must be used to pull the line to a maximum logic high level  $V_{IN}$ .

### ENTERING MANCHESTER COMMUNICATION MODE

Provided the Disable Manchester bit is not set in EEPROM, the AAS33001 continuously monitors the VCC line for valid Manchester commands. The part takes no action until a valid Manchester Access Code is received.

There are two special Manchester code commands used to activate or deactivate the serial interface and specify the output format used during Read operations:

1. Manchester Access Code: Enters Manchester Communication Mode; Manchester code output on the PWM pin. See further paragraphs for example.
2. Manchester Exit Code; returns the PWM pin to normal operation. See further paragraphs for example.

Once the Manchester Communication Mode is entered, the PWM output pin will cease to provide angle data, interrupting any data transmission in progress.

### TRANSACTION TYPES

The AAS33001 receives all commands via the VCC pin, and responds to Read commands via the PWM pin. This implementation of Manchester encoding requires the communication pulses be within a high ( $V_{MAN(H)}$ ) and low ( $V_{MAN(L)}$ ) range of voltages on the VCC line. Each transaction is initiated by a command from the controller; the sensor does not initiate any transactions. Two commands are recognized by the AAS33001: Write and Read.

### CONTROLLER MANCHESTER MESSAGE STRUCTURE

The general format of a command message frame is shown in Figure 24. Note that, in the Manchester coding used, a bit value of 1 is indicated by a falling edge within the bit boundary, and a bit value of zero is indicated by a rising edge within the bit boundary.

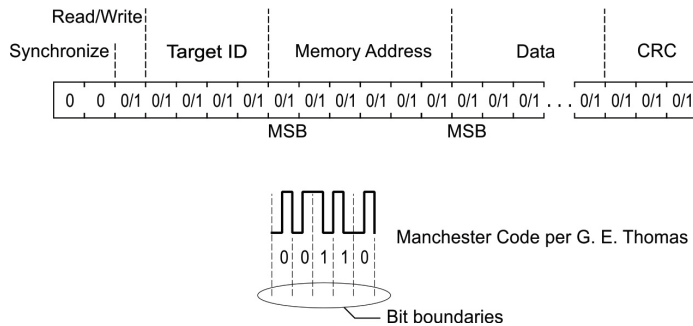

**Figure 24: Manchester Message Format**

A brief description of the bit fields is provided in Table 5:

**Table 5: Manchester Message Bit Fields**

Bits	Parameter Name	Description
2	Synchronization	Value '00' sent to identify a command start and to synchronise sensor clock
1	Read/Write	0 = write, 1 = read
4	Target ID	Select the target ID for this transaction. [ID3 ID2 ID1 ID0] are each addressed / ignored by a 1 / 0 at their address, so that a write to [0011] will write to ID0 and ID1. Reading from several sensors at the same time will result in corrupted outputs if the output pins are tied together. Writing to [0000] is a broadcast write; it is written to all sensor dies.
6	Address	Serial address for read/write
16	Data	Only for writes: 16 bit write data. Omit for read commands
3	CRC	3-bit CRC, needed for all commands

When the AAS33001 is operating in PWM mode, the Die ID value is determined by the state of the CSN and MOSI pins, as detailed in Table 6:

**Table 6: Pin Values**

MOSI	CS	ID Value
0	0	ID0
0	1	ID1
1	0	ID2
1	1	ID3

Using the 4 bits of the Chip Select field, die can be selected via their ID value, allowing up to four die to be individually addressed and providing for different group addressing schemes.

Example: If Target ID = [1 0 1 0], all die with ID3 or ID1 will be selected. If Target ID is set to [0 0 0 0], then no ID comparison will be made, allowing all sensors to be addressed at once. In case of PWM line sharing for Manchester communication, reading must be done one die at a time.

### SENSOR MANCHESTER MESSAGE STRUCTURE

If a read command with the desired register number was sent from the controller to the sensor, the device responds with a Read Response frame using the Manchester protocol over the PWM output.

The following command messages can be exchanged between the device and the external controller:

- Manchester Access Code (host to sensor)
- Manchester Exit Code (host to sensor)
- Manchester Write Command (host to sensor)
- Manchester Read Command (host to sensor)
- Manchester Read Response (sensor to host)

In addition to the contents of the requested memory location, a Return Status field is included with every Read Response. This field provides the ID used to communicate with the part and any errors which may have occurred during the transaction. These bits are:

- ID – ID (CSN/MOSI) unless BC = 1 (ID will be 00)
- BC – Broadcast; ID field was zero or SPI mode active
- AE – Abort Error; edge detection failure after sync detect
- OR – Overrun Error; A new Manchester command has been received before the previous request could be completed
- CS – Checksum error; a prior command had a checksum error

For EEPROM address information, refer to the EEPROM structure section. For serial address locations, refer to the serial register map.

### MANCHESTER ACCESS CODE

The Manchester Access Code has to be sent before other Manchester commands.

The Manchester Access Code always operates as a broadcast pulse, meaning the sensor will not look at the Target ID field. For example, if two sensors configured with ID0 and ID1 respectively are sharing a common VCC line, a Manchester Access Code with a Target ID value of [0 0 1 0] results in both sensors entering Manchester Serial Communication mode.

**Table 7: Manchester Access Code**

Bits	Parameter Name	Description
2	Synchronization	'00'
1	Read/Write	'0'
4	Target ID	'0000' (this command will always be a broadcast, even if it is addressed)
6	Address	'111111' (fixed number for Manchester access message)
16	Data	0x62D2 (fixed number for Manchester access message)
3	CRC	3-bit CRC

An example is given below, with target ID = [0 0 0 1], data = access code = 0x62D2, and CRC = '110'.

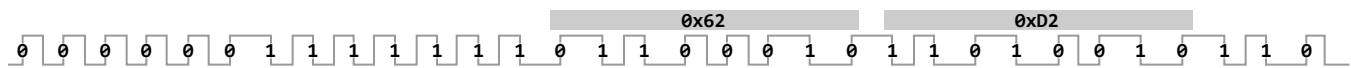

**Figure 25: Target ID = [0 0 0 1], Data = Access code = 0x62D2, CRC = '110' 4.3.5.2**



### MANCHESTER READ RESPONSE

The read response transmits data from the sensor to the controller after a read command. These data are sent by the sensor on the open-drain PWM pin. A pull-up resistor is needed for this to work.

Read from an even address returns even byte [15:8] and odd byte [7:0].

Read from an odd address returns odd byte [7:0] only. Data bits [15:8] will be zeroes.

**Table 10: Manchester Read Response**

Bits	Parameter Name	Description
2	Synchronization	'00'
2	ID	Target ID of the responding sensor die. '00' for ID0, '01' for ID1, '10' for ID2, '11' for ID3.
1	BC flag	"Broadcast": Value set to '1' if read command was a broadcast command (Target-ID set to [0 0 0 0]), '0' if not.
1	AE flag	"Abort error": Value set to '1' if a previous transaction was aborted and discarded, typically caused by incorrect bit lengths, '0' if there was no problem. The error is stored until it can be transmitted on the next read response, and is cleared afterwards.
1	OR flag	"Overrun error": If a command is sent to the sensor while the sensor is still sending a read response, and this command is completely transmitted before the read response was finished, and overrun error has occurred. This error is then stored until it can be transmitted on the next read response, and is cleared afterwards.
1	CS flag	"CRC error": Value set to '1' if a previous transaction had an incorrect CRC, '0' means there was no problem. The error is stored until it can be transmitted on the next read response, and is cleared afterwards.
16	data	Read from an Even address: even byte [15:8] and odd byte [7:0]. Read from an Odd address: odd byte [7:0] only. Data bits [15:8] will be zeroes.
3	CRC	3-bit CRC.

An example is given below where register 0x20 "angle" is read, and the response is ID '00' (ID0), the four flags are all zeroes (no errors), the data is "0x5C34", and the CRC is '100'.

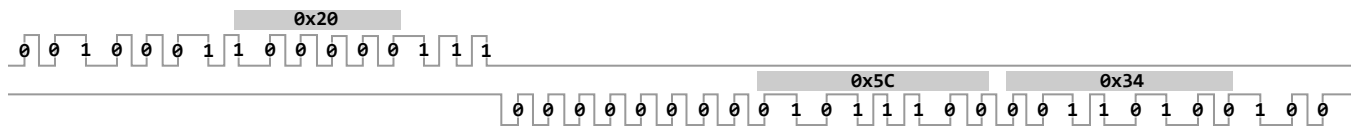

**Figure 28: ID = '00', error flag = '0000', Data = 0x5C34, CRC = '100'**

### MANCHESTER READ RESPONSE DELAY

The Manchester Read Response starts at the end of the Read Command. The response may start a ¼ bit time before the CRC is finished transmitting (overlap with last CRC bit) or ¼ after the CRC finished transmitting.

### CRC

The serial Manchester interface uses a cyclic redundancy check (CRC) for data-bit error checking of all the bits coming after the two synchronization bits. The synchronization bits are not included in the CRC. The CRC algorithm is based on the polynomial:

$$g(x) = x^3 + x + 1.$$

The calculation is represented graphically in Figure 29. The trailing 3 bits of a message frame comprise the CRC token. The CRC is initialized at 111. Data are fed into the CRC logic with MSB first. Output is sent as C2-C1-C0.

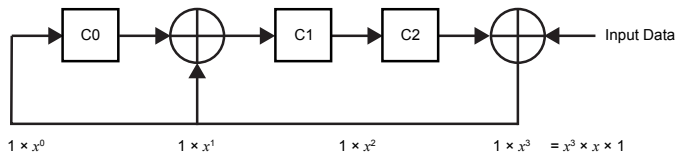

Figure 29: Manchester CRC Calculation

The 3-bit Manchester CRC can be calculated using the following C code:

```
// command: the manchester command, right justified, does not
// include the space for the CRC
// numberOfBits: number of bits in the command not including
// the 2 zero sync bits at the start of the command and the three
// CRC bits
// Returns: The three bit CRC
// This code can be tested at http://codepad.org/yqTKnfmD
uint16_t ManchesterCRC(uint64_t data, uint16_t numberOfBits)
{
    bool C0 = false;
    bool C1 = false;
    bool C2 = false;
    bool C0p = true;
    bool C1p = true;
    bool C2p = true;
    uint64_t bitMask = 1;

    bitMask <<= numberOfBits - 1;

    // Calculate the state machine
    for (; bitMask != 0; bitMask >>= 1)
    {
        C2 = C1p;
        C0 = C2p ^ ((data & bitMask) != 0);
        C1 = C0 ^ C0p;

        C0p = C0;
        C1p = C1;
        C2p = C2;
    }

    return (C2 ? 4U : 0U) + (C1 ? 2U : 0U) + (C0 ? 1U : 0U);
}
```

## EEPROM AND SHADOW MEMORY USAGE

The device uses EEPROM to permanently store configuration parameters for operation. EEPROM is user-programmable and permanently stores operation parameter values or customer information. The operation parameters are downloaded to shadow (volatile) memory at power-up. Shadow fields are initially loaded from corresponding fields in EEPROM, but can be overwritten, either by performing an extended write to the shadow addresses, or by reprogramming the corresponding EEPROM fields and power cycling the IC. Use of Shadow Memory is substantially faster than accessing EEPROM. In situations where many parameter need to be tested quickly, shadow memory is recommended for trying parameter values before permanently programming them into EEPROM. The shadow memory registers have the same format as the EEPROM and are accessed at extended addresses 0x40 higher than the equivalent EEPROM address. Unused bits in the EEPROM do not exist in the related shadow register, and will return 0 when read. Shadow registers do not contain the ECC bits. Shadow registers have the same protection restrictions as the EEPROM. All registers can be read without unlocking. The mapping of bits from registers addresses in EEPROM to their corresponding register addresses in SHADOW is shown in the EEPROM table (See “EEPROM table” section).

### Enabling EEPROM Access

To enable EEPROM write access after power-on-reset, a unlock code needs to be written to the serial register “keycode”. This involves five write commands, which should be executed after each other:

Write 0x00 to register 0x3C[15:8]

Write 0x27 to register 0x3C[15:8]

Write 0x81 to register 0x3C[15:8]

Write 0x1F to register 0x3C[15:8]

Write 0x77 to register 0x3C[15:8]

This needs to be done once after power-on reset if the customer intends to write to the EEPROM.

Writing to serial registers and reading from serial registers does not require anything special after power-on.

Reading all EEPROM cells is always possible.

### EEPROM Write Lock

It is possible to protect the EEPROM against accidental writes.

- Setting the EEPROM field “lock” to value 0xC (‘1100’ binary) will block any writes to the EEPROM, so that permanent changes are not possible anymore. Temporary changes to the setting are still possible by writing to the shadow memory, but these changes are lost after a power cycle. This lock is permanent and cannot be reversed. Reading of the settings is still possible.
- Setting the EEPROM field “lock” to value 0x3 (‘0011’ binary) will lock EEPROM writes AND shadow memory writes. This means none of the sensor settings can be changed anymore. This lock is permanent and cannot be reversed. Reading of the settings is still possible.

### EEPROM Access Exceptions and Write Lock Exceptions

It is possible to allow writes to the fields “cust” and “cust2” without having to enable EEPROM access, and even when the EEPROM write lock is enabled (“lock” = 0xC or “lock” = 0x3).

This is controlled using the EEPROM fields “cud” (customer uses disables), “del” (disable EEPROM lock) and “dur” (disable unlock requirement). By default, the fields “cud”, “del” and “dur” are all set to zero.

Table 11 shows how these settings control EEPROM access to different fields:

**Table 11: EEPROM access exceptions for field “customer” and “customer2”**

“cud” setting	“dur setting	“del” setting	“lock” setting	Writes to Customer2 (0x17) possible...	Writes to Customer (0x1F) possible...	Writes to all other EEPROM possible...
0	0	0/1	0x0	after keycode	after keycode	after keycode
0	1	0/1	0x0	always	after keycode	after keycode
0	0	0	0xC/0x3	never	never	never
0	0	1	0xC/0x3	after keycode	never	never
0	1	0	0xC/0x3	never	never	never
0	1	1	0xC/0x3	always	never	never
1	0	0/1	0x0	after keycode	after keycode	after keycode
1	1	0/1	0x0	always	always	after keycode
1	0	0	0xC/0x3	never	never	never
1	0	1	0xC/0x3	after keycode	after keycode	never
1	1	0	0xC/0x3	never	never	never
1	1	1	0xC/0x3	always	always	never

### Write Transaction to EEPROM and Other Extended Locations

Invoking an extended write access is a three-step process:

1. Write the extended address into the “ewa” register (using SPI or Manchester direct access). “ewa” is the 8-bit extended address that determines which extended memory address will be accessed.
2. Write the data that is to be transferred into the “ewd” registers (using SPI or Manchester direct access). This will take four SPI writes or 2 Manchester packets to load all 32 bits of data.
3. Invoke the extended access by writing the direct “ewcs.exw” bit with ‘1’.

The 32-bit of data in “ewd” are then written to the address specified in “ewa”.

The bit “ewcs.wdn” can be polled to determine when the write completes. This is only necessary for EEPROM writes, which can take up to 24 ms to complete. Shadow register writes complete immediately in one system clock cycle after synchronization.

For example, to write location 0x1F in the EEPROM with 0x00A45678:

- Write 0x1F to lower 8 bits of EWA register (0x1F to EWA+1 Address 0x03)

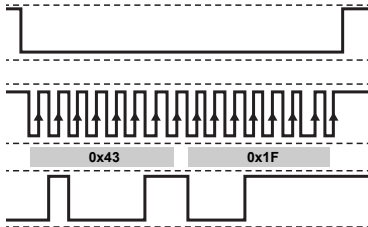

- Write 0x00A45678 to EWD (0x00 to EWD, 0xA4 to EWD+1, 0x56 to EWD+2, 0x78 to EWD+3)

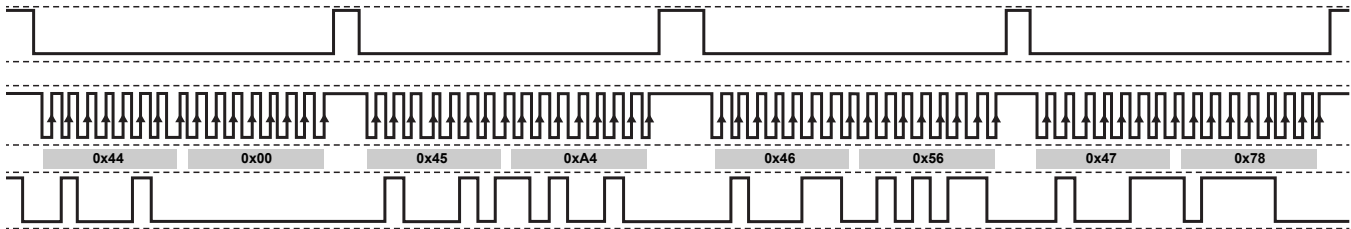

- Write 0x80 to EWCS

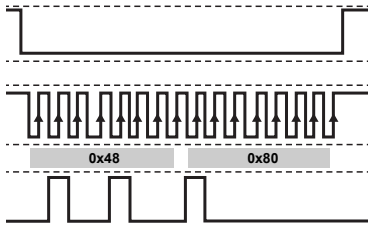

- Read EWCS+1 until bit 0 (“wdn”) is set, or wait enough time.

In the example, register 0x08 is read, so that the second output byte is from register 0x09, and we wait for bit 0 to become ‘1’, which happens in the last read.

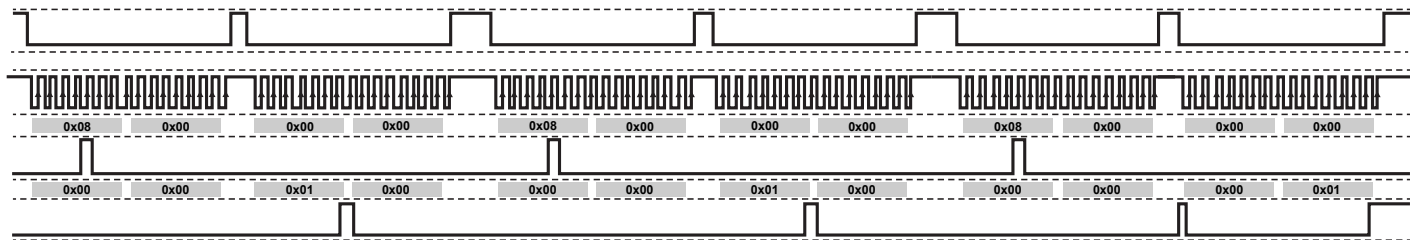

If an access violation occurs (address not unlocked), the transaction will be terminated and the corresponding “rdn” or “wdn” bit set, and the “xee” warning bit will assert. The “xee” bit in the “err” register will also set if the EEPROM write aborts.

After writing to the EEPROM, verify that the write was successful by performing an EEPROM margin check.

### EEPROM Margin Check

Due to nonidealities in transistors, current will slowly leak into or out of EEPROM cells and can, over time, cause small changes in the stored voltage level. Variances in voltage levels of the charge pump can result in a variety of stored EEPROM cell voltages when programming. If this value is marginally close to the threshold, the small drift over lifetime can cause this value to move across the threshold. This results in a corrupted EEPROM value. Since this drift happens slowly over time, if there is an issue, it may not appear for years. For this reason, it is important to perform margin testing (margining) to verify the internal voltage levels of EEPROM cells after programming, and ensure there will be no issue in the future.

Margining is performed by Allegro on all registers at final test. Since EEPROM cell voltages are only modified when writing to the cell, it is not necessary to perform margining on registers that have not been modified.

Margining is performed in two steps: the first checks the validity of the voltage stored on digital '1' cells, and the second checks the voltage stored on digital '0' cells. It is important to perform both steps to ensure there are no issues.

In order to perform margining, a value of '0b0001' must be written to the SPECIAL field of the CTRL register. This reduces the internal threshold value. Once this value is written, an EEPROM read will use this lower threshold when reading EEPROM values. Perform a read on all EEPROM registers that are being tested, and confirm they read correctly. If a stored voltage is marginal to the normal operating threshold, it will appear as a '1' when it should be a '0'.

Repeat this test with the value of '0b0010' in the SPECIAL register to raise the threshold value above normal operation. Again, read all EEPROM registers being tested. In this test, any stored high voltage that is marginal to the normal threshold will appear as a '0' when they should be '1'.

If during either test, a bit is read incorrectly, simply perform another EEPROM write of the desired values to the register, and retest the margins.

Unlike other values in the SPECIAL field, these values will persist and can be read to confirm the write was successful. As a result, the SPECIAL register must be cleared (or power cycled) to return the threshold value to its normal level.

In the figure below,  $V_{NOM(H)}$  represents the nominal voltage programmed into EEPROM cells containing a '1', and  $V_{NOM(L)}$  represents the nominal voltage programmed into EEPROM cells containing a '0'. The red and blue lines represent the actual voltage levels in the programmed cells for '1' and '0' values respectively. As can be seen, at time 0 when the margin test is run, both high and low levels still appear to be the correct value when the threshold is moved to the margin testing levels.

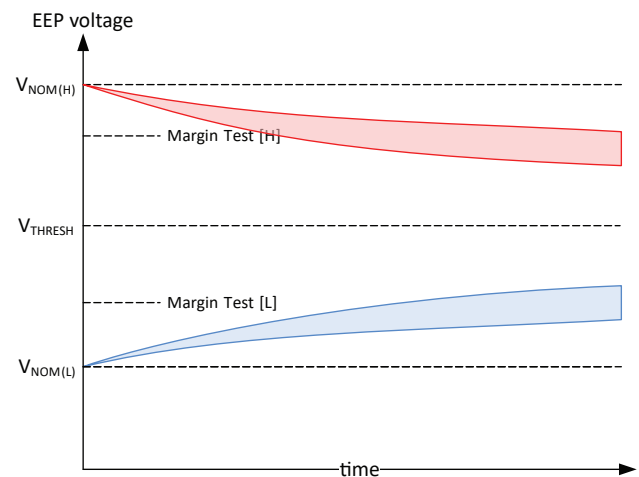

Figure 30: Example of passing programming voltages

In the figure below, the high and low voltage levels at the time of programming are further from their target. The drift over time results in these values crossing  $V_{THRESH}$ , and becoming corrupted. At time 0 when the margin test is run, these values fail, and would be reported as errors to be reprogrammed.

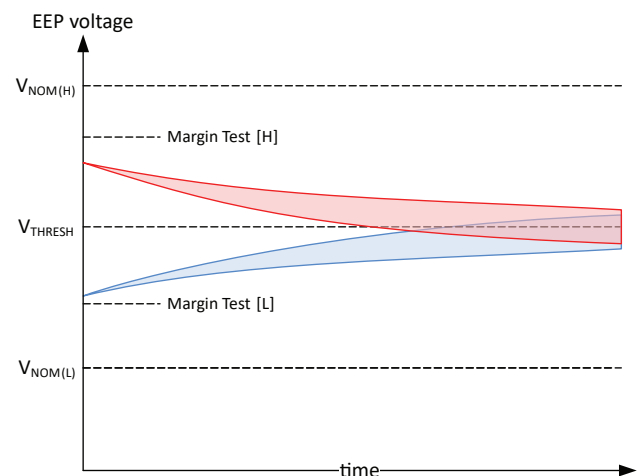

Figure 31: Example of failing programming voltages

Margining is shown below as a list of high level steps. For details on performing individual steps, see the associated sections.

1. Clear the ERR and WARN registers.
2. Write new data to EEPROM as desired.
3. Check the following flags for communication errors: ESE, EUE, XEE, IER, CRC, BSY.
4. Set CTRL.special to '0001' and confirm by writing 0xA5 to CTRL.initiate\_special.
5. Check the following flags for communication errors: ESE, EUE, XEE, IER, CRC, BSY.
6. Read all EEPROM registers changed in step 1 and verify their contents.
7. Set CTRL.special to '0010' and confirm by writing 0xA5 to CTRL.initiate\_special.
8. Check the following flags for communication errors: ESE, EUE, XEE, IER, CRC, BSY.
9. Read all EEPROM registers changed in step 1 and verify their contents.
10. If any values read in steps 3/5 are not what was set in step 1, repeat steps 1-6 for erroneous registers.
11. Set CTRL.special to '0000', or power cycle the part.

**Read Transaction from EEPROM and other Extended Locations**

Extended access is provided to additional memory space via the direct registers. This access includes the EEPROM and EEPROM shadow registers. All extended registers are up to 32 bits wide. Invoking an extended read access is a three-step process:

1. Write the extended address to be read into the “era” register (using SPI or Manchester direct access). “era” is the 8-bit extended address that determines which extended memory address will be accessed.
2. Invoke the extended access by writing the direct “ercs.ext” bit with ‘1’. The address specified in “era” is then read, and the data is loaded into the “erd” registers.
3. Read the “erd” registers (using SPI or Manchester direct access) to get the extended data. This will take multiple packets to get all 32 bits.

EEPROM read accesses may take up to 2  $\mu$ s to complete. The “ercs.rdn” bit can be polled to determine if the read access is complete before reading the data. Shadow register reads complete in one system clock cycle after synchronization. Do not attempt to read the “erd” registers if the read access is potentially in process, as it could change during the serial access and the data will be inconsistent. It is also possible that an SPI CRC error will be detected if the data changes during the serial read via the SPI interface.

For example, to read location 0x1F in the EEPROM:

- Write 0x1F to lower 8 bits of “era” (0x1F to “era+1”, Address 0x0B)

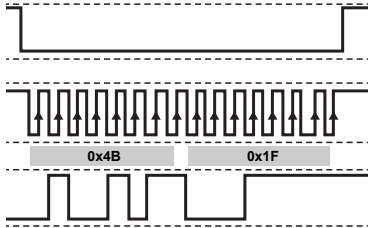

- Write 0x80 to “ercs”

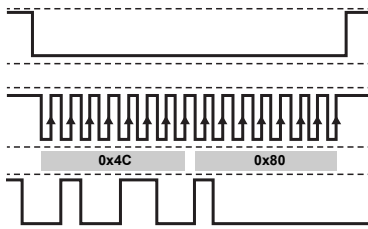

- Read “ercs”+1 until bit 0 (“rdn”) is set, or wait enough time.

In the example, register 0x0C is read, so that the last bit of the second output byte contains the “rdn” bit.

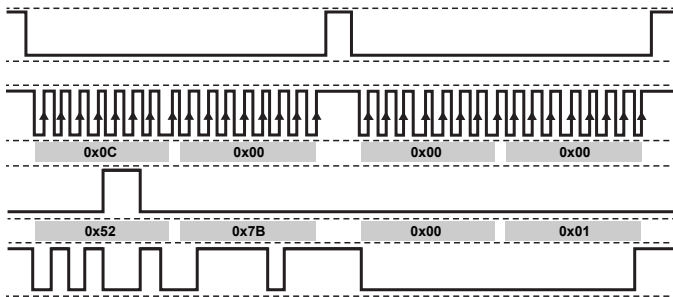

- Read “erdh” (upper 16 bits of read data)
- Read “erdl” (lower 16 bits of read data)

In the example below, the result for the data at address 0x1F is 0x58A45678. In this value,

- Bit [31:26] are the EEPROM CRC
- Bit [25:24] are unused and zero
- Bit [23:0] are the EEPROM values that can be used. These are the 24 bits containing the information 0xA45678 that was written in the EEPROM write example.

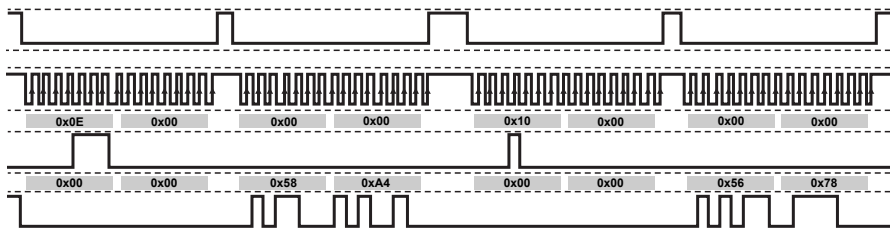

Note that it would have been possible to pipeline transactions in this example, i.e. send a new command while reading return data from the old command. This way the transaction could have been performed in 5 SPI frames instead of 8.

**Shadow Memory Read and Write Transactions**

Shadow memory Read and Write transactions are identical to those for EEPROM. Instead of addressing to the EEPROM extended address, one must address to the Shadow Extended addresses, which are located at an offset of 0x40 above the EEPROM. Refer to the EEPROM table for all addresses.

### SERIAL INTERFACE TABLE

Table 12: Primary Serial Interface Registers Bits Map

Address* (0x00)	Register Symbol	Read/Write	Addressed Byte (MSB)								Addressed Byte + 1 (MSB)								LSB Address			
			15	14	13	12	11	10	9	8	7	6	5	4	3	2	1	0				
0x02	ewa	RW	0	0	0	0	0	0	0	0	write_adr								0x03			
0x04	ewdh	RW	write_data_hi																0x05			
0x06	ewdl	RW	write_data_lo																0x07			
0x08	ewcs	WO/RO	exw	0	0	0	0	0	0	0	wip	0	0	0	0	0	0	0	0	0	wdn	0x09
0x0A	era	RW	0	0	0	0	0	0	0	0	read_adr								0x0B			
0x0C	ercs	WO/RO	exr	0	0	0	0	0	0	0	rip	0	0	0	0	0	0	0	0	0	rdn	0x0D
0x0E	erdh	RO	read_data_hi																0x0F			
0x10	erdl	RO	read_data_lo																0x11			
0x12 0x14 0x16 0x18 0x1A 0x1C	Unused	RO	0	0	0	0	0	0	0	0	0	0	0	0	0	0	0	0	0	0	0x13 0x15 0x17 0x19 0x1B 0x1D	
0x1E	ctrl	RW/WO	special				0	cls	clw	cle	initiate_special								0x1F			
0x20	ang	RO	0	ef	uv	p	angle												0x21			
0x22	sta	RO	1	0	0	0	0	0	dieid	rot	0	sdn	bdn	lbr	cstr	bip	aok	0x23				
0x24	err	RO	1	0	1	0	war	stf	avg	abi	plk	zie	eue	ofe	uvd	uva	msl	rst	0x25			
0x26	warn	RO	1	0	1	1	ier	crc	0	srw	xee	tr	ese	sat	0	bsy	msh	0	0x27			
0x28	Unused	RO	0	0	0	0	0	0	0	0	0	0	0	0	0	0	0	0	0x29			
0x2A	Unused	RO	0	0	0	0	0	0	0	0	0	0	0	0	0	0	0	0	0x2B			
0x2C	Unused	RO	0	0	0	0	0	0	0	0	0	0	0	0	0	0	0	0	0x2D			
0x2E	Unused	RO	0	0	0	0	0	0	0	0	0	0	0	0	0	0	0	0	0x2F			
0x30	hang	RO	0	ef	uv	p	angle_hys												0x31			
0x32	ang15	RO	0	angle_15																0x33		
0x34	zang	RO	0	ef	uv	p	angle_zcd												0x35			
0x36	Unused	RO	0	0	0	0	0	0	0	0	0	0	0	0	0	0	0	0	0x37			
0x38	Unused	RO	0	0	0	0	0	0	0	0	0	0	0	0	0	0	0	0	0x39			
0x3A	Unused	RO	0	0	0	0	0	0	0	0	0	0	0	0	0	0	0	0	0x3B			
0x3C	key	WO/RO	keycode								0	0	0	0	0	0	0	cul	0x3D			
0x3E	Unused	RO	0	0	0	0	0	0	0	0	0	0	0	0	0	0	0	0	0x3F			

\*Addresses that span multiple bytes are addressed by the most significant byte.

**PRIMARY SERIAL INTERFACE REGISTERS REFERENCE****Location 0x02:0x03 (“ewa”)****ewa.write\_adr**

The field “write\_adr” is a bit field located at address 0x02[7:0]. This bit field is part of the location “ewa”.

8-bit address for extended writes. Writes require unlock.

0x00-0x1F: EEPROM (takes about 24 ms)  
0x40-0x5F: Shadow

**Location 0x04:0x05 (“ewdh”)****ewdh.write\_data\_hi**

The field “write\_data\_hi” is a bit field located at address 0x04[15:0]. This bit field is part of the location “ewdh”.

Upper 16 bits of data for an extended write operation.

**Location 0x06:0x07 (“ewdl”)****ewdl.write\_data\_lo**

The field “write\_data\_lo” is a bit field located at address 0x06[15:0]. This bit field is part of the location “ewdl”.

Lower 16 bits of data for an extended write operation.

**Location 0x08:0x09 (“ewcs”)****ewcs.wdn**

The field “wdn” is a bit located at address 0x08[0]. This bit is part of the location “ewcs”.

Write done when wdn = ‘1’; wdn clears when exw is set to ‘1’.

**ewcs.wip**

The field “wip” is a bit located at address 0x08[8]. This bit is part of the location “ewcs”.

Write in progress when ‘1’.

**ewcs.exw**

The field “exw” is a bit located at address 0x08[15]. This bit is part of the location “ewcs”.

Initiate extended write by writing with ‘1’. Set “wip” and clears “wdn”. Write-only, always reads back 0.

**Location 0x0A:0x0B (“era”)****era.read\_adr**

The field “read\_adr” is a bit field located at address 0x0A[7:0]. This bit field is part of the location “era”.

8-bit address for extended reads.

0x00-0x1F: EEPROM (takes about 2 μs)  
0x40-0x5F: Shadow

NOTE: After LBIST or a reload of EEPROM values, this value of read\_adr will be changed.

**Location 0x0C:0x0D (“ercs”)****ercs.rdn**

The field “rdn” is a bit located at address 0x0C[0]. This bit is part of the location “ercs”.

Read done when ‘1’, clears when “exr” set to ‘1’.

**ercs.rip**

The field “rip” is a bit located at address 0x0C[8]. This bit is part of the location “ercs”.

Read in progress when ‘1’.

**ercs.exr**

The field “exr” is a bit located at address 0x0C[15]. This bit is part of the location “ercs”.

Initiate extended read by writing with ‘1’. Set “rip” and clears “rdn”. Write-only, always reads back 0.

**Location 0x0E:0x0F (“erdh”)****erdh.read\_data\_hi**

The field “read\_data\_hi” is a bit field located at address 0x0E[15:0]. This bit field is part of the location “erdh”.

Upper 16 bits of data from extended read operation, valid when RDN set to ‘1’.

### Location 0x10:0x11 (“erdl”)

#### erdl.read\_data\_lo

The field “read\_data\_lo” is a bit field located at address 0x10[15:0]. This bit field is part of the location “erdl”.

Lower 16 bits of data from extended read operation, valid when RDN set to ‘1’.

### Location 0x1E:0x1F (“ctrl”)

#### ctrl.initiate\_special

The field “initiate\_special” is a bit field located at address 0x1E[7:0]. This bit field is part of the location “ctrl”.

For certain actions from “special” bit field, a code must be set to “initiate\_special”. These are to be written into this bit field.

- 0xB9 initiates CVH self-test or functional BIST.
- 0xA5 initiates EEPROM margin or EEPROM reload.
- 0x5A initiates hard reset.

Read always returns 0x00.

#### ctrl.cle

The field “cle” is a bit located at address 0x1E[8]. This bit is part of the location “ctrl”.

Clear error register “err” when written with ‘1’. Clears bits that were previously read from the “err”. Bits that were not yet read will not be cleared, so the user needs to read ERR first. Write-only, always returns 0.

#### ctrl.clw

The field “clw” is a bit located at address 0x1E[9]. This bit is part of the location “ctrl”.

Clear warning (WARN) register when set to ‘1’. Clears bits that were previously read from the WARN, so need to read WARN first. Write-only, always returns 0.

#### ctrl.cls

The field “cls” is a bit located at address 0x1E[10]. This bit is part of the location “ctrl”.

Clear bits “sdn” and “bdn” from “status” register when set to ‘1’. Write-only, returns 0 when read.

#### ctrl.special

The field “special” is a bit field located at address 0x1E[15:12]. This bit field is part of the location “ctrl”.

Special actions. Some of the actions will only be invoked after the “initiate\_special” field is written with the correct value. This field will return 0x00 on completion. Self-tests may be run in parallel.

- 0000 - No action.
- 0001 - Enable EEPROM low voltage margining.
- 0010 - Enable EEPROM high voltage margining.
- 0101 - Reload EEPROM. Requires unlock of part. Starts after writing 0xA5 to “initiate\_special”.
- 0111 - Hard reset. Requires unlock of part. Starts after writing 0x5A to “initiate\_special”.
- 1001 - Run CVH self-test. Starts after writing 0xB9 to “initiate\_special”.
- 1010 - Run logic BIST. Starts after writing 0xB9 to “initiate\_special”.
- 1011 - Run CVH self-test and logic-BIST in parallel. Starts after writing 0xB9 to “initiate\_special”.

### Location 0x20:0x21 (“ang”)

#### ang.angle

The field “angle” is a bit field located at address 0x20[11:0]. This bit field is part of the location “ang”.

Angle from PLL after processing. Angle in degrees = unsigned 12-bit value  $\times$  (360 / 4096).

#### ang.p

The field “p” is a bit located at address 0x20[12]. This bit is part of the location “ang”.

Odd parity computed across all bits of this register. Value is chosen in such a way that there should always be an odd number of 1’s in the 16-bit word.

#### ang.uv

The field “uv” is a bit located at address 0x20[13]. This bit is part of the location “ang”.

Undervoltage flag (real time). OR of “uva” and “uvd” undervoltage flags. Conditions are realtime, but are masked by the Shadow mask bits.

**ang.ef**

The field “ef” is a bit located at address 0x20[14]. This bit is part of the location “ang”.

Error flag – will be ‘1’ if any unmasked bit in ERR or WARN is set.

**Location 0x22:0x23 (“sta”)****sta.aok**

The field “aok” is a bit located at address 0x22[0]. This bit is part of the location “sta”.

Angle output OK. PLL is in lock

**sta.bip**

The field “bip” is a bit located at address 0x22[1]. This bit is part of the location “sta”.

Boot in progress.

**sta.cstr**

The field “cstr” is a bit located at address 0x22[2]. This bit is part of the location “sta”.

CVH self-test running.

**sta.lbr**

The field “lbr” is a bit located at address 0x22[3]. This bit is part of the location “sta”.

LBIST running.

**sta.bdn**

The field “bdn” is a bit located at address 0x22[4]. This bit is part of the location “sta”.

Boot complete. EEPROM loaded and any startup self-tests are complete.

**sta.sdn**

The field “sdn” is a bit located at address 0x22[5]. This bit is part of the location “sta”.

Special access (from ctrl register) done. Clears to ‘0’ when SPECIAL triggered, set ‘1’ when complete.

**sta.rot**

The field “rot” is a bit located at address 0x22[7]. This bit is part of the location “sta”.

Rotation direction based on hysteresis  
(‘0’ = increasing angle, ‘1’ = decreasing angle).

**sta.dieid**

The field “dieid” is a bit field located at address 0x22[9:8]. This bit field is part of the location “sta”.

DIE ID from EEPROM (for multi-die packages).

**Location 0x24:0x25 (“err”)**

This is the error register. All errors are latched, meaning they will remain high after they occurred just once. Errors need to be read and then cleared in order to remove them. It is important that the user clears errors, so that subsequent errors become visible. This is especially important for the “rst” error flag (reset), which is always enabled after power on. Not removing it means that an unexpected reset cannot be discovered afterwards.

**err.rst**

The field “rst” is a bit located at address 0x24[0]. This bit is part of the location “err”.

Reset condition. Sets on power-on reset or on hard reset. Does not set on LBIST.

**err.msl**

The field “msl” is a bit located at address 0x24[1]. This bit is part of the location “err”.

Magnetic sense low fault. Magnetic sense was below the “mag\_thres\_lo” limit.

**err.uva**

The field “uva” is a bit located at address 0x24[2]. This bit is part of the location “err”.

Undervoltage detector tripped. Will be set again after clearing if the undervoltage situation persists. Based on analog regulator.

**err.uvd**

The field “uvd” is a bit located at address 0x24[3]. This bit is part of the location “err”.

Undervoltage detector tripped. Will be set again after clearing if the undervoltage situation persists.

**err.ofe**

The field “ofe” is a bit located at address 0x24[4]. This bit is part of the location “err”.

Oscillator frequency watchdog tripped.

**err.eue**

The field “eue” is a bit located at address 0x24[5]. This bit is part of the location “err”.

EEPROM uncorrectable error. A multi-bit EEPROM read occurred.

**err.zie**

The field “zie” is a bit located at address 0x24[6]. This bit is part of the location “err”.

Zero crossing integrity error. A zero crossing did not occur within the maximum time expected, likely indicating missing magnet, an extreme rotation speed, or a sensor defect.

**err.plk**

The field “plk” is a bit located at address 0x24[7]. This bit is part of the location “err”.

PLL lost lock.

**err.abi**

The field “abi” is a bit located at address 0x24[8]. This bit is part of the location “err”.

ABI integrity fault. The quadrature integrity of the ABI could not be maintained.

**err.avg**

The field “avg” is a bit located at address 0x24[9]. This bit is part of the location “err”.

Angle averaging error. The ORATE is too high for the velocity and the averaging is corrupted.

**err.stf**

The field “stf” is a bit located at address 0x24[10]. This bit is part of the location “err”.

Self-test failure.

**err.war**

The field “war” is a bit located at address 0x24[11]. This bit is part of the location “err”.

Warning. Some unmasked error bits are set in the WARN register. If WAR in mask register “MSK” is set, this will be forced to 0.

**Location 0x26:0x27 (“warn”)****warn.msh**

The field “msh” is a bit located at address 0x26[1]. This bit is part of the location “warn”.

Magnetic sense high fault. Magnetic sense has exceeded the “mag\_thres\_hi” limit.

**warn.bsy**

The field “bsy” is a bit located at address 0x26[2]. This bit is part of the location “warn”.

Extended access overflow. An EXW or EXR was initiated while previous extended read or write was in progress.

**warn.sat**

The field “sat” is a bit located at address 0x26[4]. This bit is part of the location “warn”.

Aggregate saturation flag. Shows that any internal signals have saturated, likely to have been caused by extremely strong or weak fields.

**warn.ese**

The field “ese” is a bit located at address 0x26[5]. This bit is part of the location “warn”.

EEPROM soft error. A correctable (single-bit) EEPROM read occurred.

**warn.tr**

The field “tr” is a bit located at address 0x26[6]. This bit is part of the location “warn”.

Temperature out of range. The temperature sensor calculated a temperature below  $-60^{\circ}\text{C}$  or above  $180^{\circ}\text{C}$ . Temperature will saturate at those limits.

**warn.xee**

The field “xee” is a bit located at address 0x26[7]. This bit is part of the location “warn”.

Extended execute error. A command initiated by an extended write failed. Write failed due to access error (not unlocked) or EEPROM write failure.

**warn.srw**

The field “srw” is a bit located at address 0x26[8]. This bit is part of the location “warn”.

Slew rate warning. This warning is asserted if the ABI slew rate limiting is enabled and a condition that requires the limiting to be applied has occurred.

**warn.crc**

The field “crc” is a bit located at address 0x26[10]. This bit is part of the location “warn”.

Incoming SPI CRC error. Packet was discarded.

**warn.ier**

The field “ier” is a bit located at address 0x26[11]. This bit is part of the location “warn”.

Interface error. Invalid number of bits in SPI packet, or bit 15 of MOSI data = ‘1’. Packet was discarded.

Also Manchester error.

**Location 0x28:0x29 (“tsen”)****tsen.temperature**

The field “temperature” is a bit field located at address 0x28[11:0]. This bit field is part of the location “tsen”.

Current junction temperature from internal temperature sensor relative to 25°C (signed value). Value is in 1/8 of a degree. Temperature °C = (tsen.temperature / 8) + 25.0.

**Location 0x2A:0x2B (“field”)****field.gauss**

The field “gauss” is a bit field located at address 0x2A[11:0]. This bit field is part of the location “field”.

Field strength in gauss.

**Location 0x30:0x31 (“hang”)****hang.angle\_hys**

The field “angle\_hys” is a bit field located at address 0x30[11:0]. This bit field is part of the location “hang”.

Angle from PLL after processing. Angle in degrees = unsigned 12-bit value × (360 / 4096).

**hang.p**

The field “p” is a bit located at address 0x30[12]. This bit is part of the location “hang”.

Odd parity computed across all bits of this register. Value is chosen in such a way that there should always be an odd number of 1’s in the 16-bit word.

**hang.uv**

The field “uv” is a bit located at address 0x30[13]. This bit is part of the location “hang”.

Undervoltage flag (real time). OR of analog and digital UV flags. Conditions are realtime, but are masked by the Shadow mask bits.

**hang.ef**

The field “ef” is a bit located at address 0x30[14]. This bit is part of the location “hang”.

Error flag. Will be ‘1’ if any unmasked bit in ERR or WARN is set.

**Location 0x32:0x33 (“ang15”)****ang15.angle\_15**

The field “angle\_15” is a bit field located at address 0x32[14:0]. This bit field is part of the location “ang15”.

15-bit compensated angle (not rounded).

**Location 0x34:0x35 (“zang”)****zang.angle\_zcd**

The field “angle\_zcd” is a bit field located at address 0x34[11:0]. This bit field is part of the location “zang”.

Angle from zero-crossing-detector, which is used to verify that the PLL angle is correct.

Angle in degrees = unsigned 12-bit value × (360 / 4096).

**zang.p**

The field “p” is a bit located at address 0x34[12]. This bit is part of the location “zang”.

Odd parity computed across all bits of this register. Value is chosen in such a way that there should always be an odd number of 1’s in the 16-bit word.

**zang.uv**

The field “uv” is a bit located at address 0x34[13]. This bit is part of the location “zang”.

Undervoltage flag (real time). OR of analog and digital UV flags. Conditions are realtime, but are masked by the Shadow mask bits.

**zang.ef**

The field “ef” is a bit located at address 0x34[14]. This bit is part of the location “zang”.

Error flag. Will be ‘1’ if any unmasked bit in ERR or WARN is set.

**Location 0x3C:0x3D (“key”)****key.cul**

The field “cul” is a bit located at address 0x3C[0]. This bit is part of the location “key”.

Customer unlocked if ‘1’.

**key.keycode**

The field “keycode” is a bit field located at address 0x3C[15:8]. This bit field is part of the location “key”.

Customer access keycode is entered here, using five subsequent write commands with the numbers: 0x00, 0x27, 0x81, 0x1F, 0x77.

Always reads back 0.

### EEPROM AND SHADOW REGISTER TABLE

The EEPROM register bitmap is shown below. Addresses that span multiple bytes are addressed by the most significant byte. All EEPROM content can be read by the user. The EEPROM

ECC field in bits [31:26] of each word are not shown here. Bits [25:24] of each EEPROM word are unused and not shown here, but are included in the ECC.

**Table 13: EEPROM/Shadow Memory Map**

Shadow Memory Address	EEPROM Address	Register Name	Bits																									
			23	22	21	20	19	18	17	16	15	14	13	12	11	10	9	8	7	6	5	4	3	2	1	0		
-	0x17	CU2	customer 2																									
0x58	0x18	PWE	-	-	-	-	-	-	-	-	-	-	-	-	tr	msh	sat	ese	msl	uv	avg	zie	plk	stf	eue	ofe		
0x59	0x19	ABI	-	-	abi_slew_time						inv	-	-	ahe	-	-	index_mode		wdh	plh	ioe	uvw	resolution_pairs					
0x5A	0x1A	MSK	ierm	crclm	-	srwm	xeem	trm	esem	satm	tcwm	bsym	mshm	tovm	warm	stfm	avgm	abim	plkm	ziem	euem	ofem	uvdm	uvam	mslm	rstm		
0x5B	0x1B	PWI	pen	pwm_band			pwm_freq				-	phe	peo	pes	eli	ls	wp_hys	zal	wp_thres			dm	-	s17	sc			
0x5C	0x1C	ANG	orate				rd	ro	hysteresis						zero_offset													
0x5D	0x1D	-	-	-	-	-	-	cycle_time						-	-	-	-	-	-	-	-	-	-	-	-	-	-	-
0x5E	0x1E	COM	lock				lbe	cse	dur	del	-	cud	dst	dhr	mag_thres_hi						mag_thres_lo							
-	0x1F	CUS	customer																									
0x60	0x20	LIN00	Linearization Error Segment 1												Linearization Error Segment 0													
0x61	0x21	LIN01	Linearization Error Segment 3												Linearization Error Segment 2													
...	...	...	...												---													
0x6E	0x2E	LIN14	Linearization Error Segment 29												Linearization Error Segment 28													
0x6F	0x2F	LIN15	Linearization Error Segment 31												Linearization Error Segment 30													
0x80	-	ALV	Alive counter																									

**EEPROM REFERENCE****Location 0x17 (“CU2”)**

Customer-useable field, intended for storing data.

This word can be written even if EEPROM is locked. Write may be allowed without the unlock code based on COM.dur and COM.del settings (see word 0x1E).

**CU2.customer 2**

The field “customer 2” is a bit field located at address 0x17[23:0]. This bit field is part of the location “CU2”.

Customer-useable field, intended for storing data.

Depending on COM.dur and COM.del settings, this word can be written even if EEPROM is locked. Details are given in the chapter “EEPROM write lock”.

**Location 0x18 (“PWE”)****PWE.ofe**

The field “ofe” is a bit located at address 0x18[0]. This bit is part of the location “PWE”.

PWM oscillator frequency watchdog error enable. Duty cycle output 5% at half the selected PWM frequency.

**PWE.eue**

The field “eue” is a bit located at address 0x18[1]. This bit is part of the location “PWE”.

PWM EEPROM uncorrectable error enable. Duty cycle 10.625% at half the selected PWM frequency.

**PWE.stf**

The field “stf” is a bit located at address 0x18[2]. This bit is part of the location “PWE”.

PWM self-test failure error enable. Duty cycle 16.25% at half the selected PWM frequency.

**PWE.plk**

The field “plk” is a bit located at address 0x18[3]. This bit is part of the location “PWE”.

PWM PLL Lost Lock error enable. Duty cycle 21.875% at half the selected PWM frequency.

**PWE.zie**

The field “zie” is a bit located at address 0x18[4]. This bit is part of the location “PWE”.

PWM zero crossing integrity error enable. Duty cycle 27.5% at half the selected PWM frequency.

**PWE.avg**

The field “avg” is a bit located at address 0x18[5]. This bit is part of the location “PWE”.

PWM angle averaging error enable. Duty cycle is 33.125% at half the selected PWM frequency.

**PWE.uv**

The field “uv” is a bit located at address 0x18[6]. This bit is part of the location “PWE”.

PWM undervoltage Fault enable (analog or digital). Duty cycle 38.75% at half the selected PWM frequency.

**PWE.msl**

The field “msl” is a bit located at address 0x18[7]. This bit is part of the location “PWE”.

PWM magnetic Sense Low Fault enable. Duty cycle 44.375% at half the selected PWM frequency.

**PWE.ese**

The field “ese” is a bit located at address 0x18[8]. This bit is part of the location “PWE”.

PWM EEPROM Soft Error enable. Duty cycle 50% at half the selected PWM frequency.

**PWE.sat**

The field “sat” is a bit located at address 0x18[9]. This bit is part of the location “PWE”.

PWM saturation warning enable. Duty cycle 55.625% at half the selected PWM frequency.

**PWE.msh**

The field “msh” is a bit located at address 0x18[10]. This bit is part of the location “PWE”.

PWM magnetic sense high fault enable. Duty cycle 61.25% at half the selected PWM frequency.

**PWE.tr**

The field “tr” is a bit located at address 0x18[11]. This bit is part of the location “PWE”.

PWM temperature sensor out of range error enable. Duty cycle 66.875% at half the selected PWM frequency.

**Location 0x19 (“ABI”)****ABI.resolution\_pairs**

The field “resolution\_pairs” is a bit field located at address 0x19[3:0]. This bit field is part of the location “ABI”.

ABI or UVW resolution.

If ABI selected, this selects AB cycle counts per rotation. Cycle count =  $2^{(14-n)}$  where n is selected code.

If UVW selected, this is the number of pole pairs – 1.

**ABI.uvw**

The field “uvw” is a bit located at address 0x19[4]. This bit is part of the location “ABI”.

Incremental outputs UVW (1), ABI (0).

**ABI.ioe**

The field “ioe” is a bit located at address 0x19[5]. This bit is part of the location “ABI”.

Incremental output pins enable (see UVW).

**ABI.plh**

The field “plh” is a bit located at address 0x19[6]. This bit is part of the location “ABI”.

Enable ABI all high (before inversions) as error mode if PLL is unlocked.

**ABI.wdh**

The field “wdh” is a bit located at address 0x19[7]. This bit is part of the location “ABI”.

Enable ABI all high (before inversions) as error mode if high-frequency watchdog trips.

**ABI.index\_mode**

The field “index\_mode” is a bit field located at address 0x19[9:8]. This bit field is part of the location “ABI”.

ABI index mode, defines width and placement of index pulse.

Mode 0: Angle = 0

Mode 1: Angle = –R or 0

Mode 2: Angle = –R, 0 or +R

Mode 3: Angle = –2R, –R, 0 or +R

**ABI.ahe**

The field “ahe” is a bit located at address 0x19[12]. This bit is part of the location “ABI”.

ABI hysteresis enable. If 1, use hysteresis on angle going to ABI.

**ABI.inv**

The field “inv” is a bit located at address 0x19[15]. This bit is part of the location “ABI”.

Invert ABI or UVW signals.

**ABI.abi\_slew\_time**

The field “abi\_slew\_time” is a bit field located at address 0x19[21:16]. This bit field is part of the location “ABI”.

ABI slew rate limit. ‘0’ mean slew rate limiter is disabled. Otherwise,  $(N + 1) \times 125$  ns (nominal) is the minimum edge-to-edge time for the ABI output. This limits the maximum ABI velocity. Reducing the ABI output resolution may be useful to counteract this effect.

**Location 0x1A (“MSK”)****MSK.rstm**

The field “rstm” is a bit located at address 0x1A[0]. This bit is part of the location “MSK”.

Reset mask. If set to ‘1’, the corresponding error will not affect the error flag “ef”.

**MSK.mslm**

The field “mslm” is a bit located at address 0x1A[1]. This bit is part of the location “MSK”.

Magnetic Sense Low Fault Mask. If set to ‘1’, the corresponding error will not affect the error flag “ef”.

**MSK.uvam**

The field “uvam” is a bit located at address 0x1A[2]. This bit is part of the location “MSK”.

Analog undervoltage Fault Mask. If set to ‘1’, the corresponding error will not affect the error flag “ef”.

**MSK.uvdm**

The field “uvdm” is a bit located at address 0x1A[3]. This bit is part of the location “MSK”.

Digital undervoltage Fault Mask. If set to ‘1’, the corresponding error will not affect the error flag “ef”.

**MSK.ofem**

The field “ofem” is a bit located at address 0x1A[4]. This bit is part of the location “MSK”.

Oscillator frequency watchdog error mask. If set to ‘1’, the corresponding error will not affect the error flag “ef”.

**MSK.euem**

The field “euem” is a bit located at address 0x1A[5]. This bit is part of the location “MSK”.

EEPROM Uncorrectable Error Mask. If set to ‘1’, the corresponding error will not affect the error flag “ef”.

**MSK.ziem**

The field “ziem” is a bit located at address 0x1A[6]. This bit is part of the location “MSK”.

Zero crossing integrity error mask. If set to ‘1’, the corresponding error will not affect the error flag “ef”.

**MSK.plkm**

The field “plkm” is a bit located at address 0x1A[7]. This bit is part of the location “MSK”.

PLL Lost Lock error mask. If set to ‘1’, the corresponding error will not affect the error flag “ef”.

**MSK.abim**

The field “abim” is a bit located at address 0x1A[8]. This bit is part of the location “MSK”.

ABI integrity fault mask. If set to ‘1’, the corresponding error will not affect the error flag “ef”.

**MSK.avgm**

The field “avgm” is a bit located at address 0x1A[9]. This bit is part of the location “MSK”.

Angle averaging fault mask. If set to ‘1’, the corresponding error will not affect the error flag “ef”.

**MSK.stfm**

The field “stfm” is a bit located at address 0x1A[10]. This bit is part of the location “MSK”.

Self-test failure error mask. If set to ‘1’, the corresponding error will not affect the error flag “ef”.

**MSK.warm**

The field “warm” is a bit located at address 0x1A[11]. This bit is part of the location “MSK”.

If set to 1, will not set WAR bit in the ERR register when unmasked warnings are present.

**MSK.mshm**

The field “mshm” is a bit located at address 0x1A[13]. This bit is part of the location “MSK”.

Magnetic Sense High Fault Mask. If set to ‘1’, the corresponding error will not affect the error flag “ef”.

**MSK.bsym**

The field “bsym” is a bit located at address 0x1A[14]. This bit is part of the location “MSK”.

Indirect access busy error mask. If set to ‘1’, the corresponding error will not affect the error flag “ef”.

**MSK.satm**

The field “satm” is a bit located at address 0x1A[16]. This bit is part of the location “MSK”.

Aggregate saturation flag mask. If set to ‘1’, the corresponding error will not affect the error flag “ef”.

**MSK.esem**

The field “esem” is a bit located at address 0x1A[17]. This bit is part of the location “MSK”.

EEPROM Soft Error Mask. If set to ‘1’, the corresponding error will not affect the error flag “ef”.

**MSK.trm**

The field “trm” is a bit located at address 0x1A[18]. This bit is part of the location “MSK”.

Temperature sensor out of range error mask. If set to ‘1’, the corresponding error will not affect the error flag “ef”.

**MSK.xeem**

The field “xeem” is a bit located at address 0x1A[19]. This bit is part of the location “MSK”.

Execute Error Mask. If set to ‘1’, the corresponding error will not affect the error flag “ef”.

**MSK.srwm**

The field “srwm” is a bit located at address 0x1A[20]. This bit is part of the location “MSK”.

Slew rate warning mask. If set to ‘1’, the corresponding error will not affect the error flag “ef”.

**MSK.crcm**

The field “crcm” is a bit located at address 0x1A[22]. This bit is part of the location “MSK”.

CRC Error Mask (SPI). If set to ‘1’, the corresponding error will not affect the error flag “ef”.

**MSK.ierm**

The field “ierm” is a bit located at address 0x1A[23]. This bit is part of the location “MSK”.

Interface Error Mask. If set to ‘1’, the corresponding error will not affect the error flag “ef”.

**Location 0x1B (“PWI”)****PWI.sc**

The field “sc” is a bit located at address 0x1B[0]. This bit is part of the location “PWI”.

SPI CRC (incoming) validated if SC = 1, ignored if SC = 0.

**PWI.s17**

The field “s17” is a bit located at address 0x1B[1]. This bit is part of the location “PWI”.

SPI ignore 17th clock to allow negative edge host sampling.

**PWI.dm**

The field “dm” is a bit located at address 0x1B[3]. This bit is part of the location “PWI”.

Disable Manchester interface. If ‘1’, any Manchester input on VCC will be ignored.

**PWI.zal**

The field “zal” is a bit located at address 0x1B[7]. This bit is part of the location “PWI”.

Zero offset after linearization:

- 0 = Before linearization and rotation
- 1 = After linearization

**PWI.ls**

The field “ls” is a bit located at address 0x1B[10]. This bit is part of the location “PWI”.

Linearization scale:

- 0 = ±22.5 degrees
- 1 = ±45 degrees

**PWI.eli**

The field “eli” is a bit located at address 0x1B[11]. This bit is part of the location “PWI”.

Enable linearization:

- 0 = Disabled
- 1 = Enabled

**PWl.pes**

The field “pes” is a bit located at address 0x1B[12]. This bit is part of the location “PWI”.

PWM error select (if “peo” = 1).

0 - PWM tristated, must reset (or set “peo” back to 0 in shadow) to release the PWM output.

1 - PWM carrier frequency halved and highest priority error output on PWM as selected duty cycle. See “PWM Output” section for more details.

**PWl.peo**

The field “peo” is a bit located at address 0x1B[13]. This bit is part of the location “PWI”.

PWM error output enable. If ‘1’, “pes” selects the response to an enabled error (see “abe” word).

**PWl.phe**

The field “phe” is a bit located at address 0x1B[14]. This bit is part of the location “PWI”.

PWM hysteresis enable. If 1, use hysteresis on angle going to PWM.

**PWl.pwm\_freq**

The field “pwm\_freq” is a bit field located at address 0x1B[19:16]. This bit field is part of the location “PWI”.

PWM frequency select. See “PWM Output” section for more details.

**PWl.pwm\_band**

The field “pwm\_band” is a bit field located at address 0x1B[22:20]. This bit field is part of the location “PWI”.

PWM frequency band. See “PWM Output” section for more details.

**PWl.pen**

The field “pen” is a bit located at address 0x1B[23]. This bit is part of the location “PWI”.

PWM Enable = 1. If 0, PWM is tristate.

**Location 0x1C (“ANG”)****ANG.zero\_offset**

The field “zero\_offset” is a bit field located at address 0x1C[11:0]. This bit field is part of the location “ANG”.

Post-compensation zero offset (or DC adjust) at angle resolution. This value is subtracted from the measured angle.

**ANG.hysteresis**

The field “hysteresis” is a bit field located at address 0x1C[17:12]. This bit field is part of the location “ANG”.

Angle hysteresis threshold, angle resolution  $\times$  4 (14 bit). Range is about 0 to 1.384 degrees.

**ANG.ro**

The field “ro” is a bit located at address 0x1C[18]. This bit is part of the location “ANG”.

Rotation Direction (post-linearization). If set to 0, increasing angle movement is in the clockwise direction when looking down on the top of the die. If set to 1, increasing angle movement is in the counter-clockwise direction.

**ANG.rd**

The field “rd” is a bit located at address 0x1C[19]. This bit is part of the location “ANG”.

Rotate die. Rotates final angle by 180 degrees. This is the very last step in the angle processing algorithm. The sensor is Allegro factory-calibrated to deliver identical field directions for both dies. If the user want the two outputs to be 180° offset from each other, this setting is a convenient way to do so.

**ANG.orate**

The field “orate” is a bit field located at address 0x1C[23:20]. This bit field is part of the location “ANG”.

Reduces the output rate by averaging samples.  $2^{\text{orate}}$  samples will be averaged. ORATE values above 12 are reduced to 12 in the logic, meaning that up to 4096 samples = 4 ms can be selected as averaging time.

### Location 0x1D (“LPC”)

#### LPC.cycle\_time

The field “cycle\_time” is a bit field located at address 0x1D[17:12]. This bit field is part of the location “LPC”.

Alive counter increment rate in 8.192 ms increments with cycle time =  $[(N + 1) \times 8.192 \text{ ms}]$ .

### Location 0x1E (“COM”)

#### COM.mag\_thres\_lo

The field “mag\_thres\_lo” is a bit field located at address 0x1E[5:0]. This bit field is part of the location “COM”.

Magnetic field low comparator value, field value equals low field error threshold in gauss divided by 16.

If set to 0, low threshold is disabled.

00 0000: Low field flag disabled  
00 0001: 16 gauss  
00 0010: 32 gauss  
...  
00 1101: 208 gauss (factory setting)  
...  
11 1111: 1108 gauss

#### COM.mag\_thres\_hi

The field “mag\_thres\_hi” is a bit field located at address 0x1E[11:6]. This bit field is part of the location “COM”.

Magnetic field high comparator value, field value equals maximum field threshold in gauss divided by 32. If set to 0, high threshold is disabled.

00 0000: High field flag disabled  
00 0001: 32 gauss  
00 0010: 64 gauss  
...  
10 0101: 1184 gauss (factory setting)  
...  
11 1111: 2016 gauss

#### COM.dhr

The field “dhr” is a bit located at address 0x1E[12]. This bit is part of the location “COM”.

Disable hard reset in serial CTRL register special if ‘1’.

#### COM.dst

The field “dst” is a bit located at address 0x1E[13]. This bit is part of the location “COM”.

Disable self-test initiation in serial CTRL register special if ‘1’.

#### COM.cud

The field “cud” is a bit located at address 0x1E[14]. This bit is part of the location “COM”.

If ‘1’, the “customer” word 0x1F will use the “dur” and “del” configuration in addition to the “customer2” word 0x17.

#### COM.del

The field “del” is a bit located at address 0x1E[16]. This bit is part of the location “COM”.

Disable EEPROM lock for CUST2 (EEPROM word 0x17) and, if CUD = 1, CUST word 0x1F. EEPROM lock will not affect write-ability of word 0x17 (and 0x1F if enabled).

#### COM.dur

The field “dur” is a bit located at address 0x1E[17]. This bit is part of the location “COM”.

Disable unlock requirement for CUST2 (EEPROM word 0x17) and if CUD = 1, CUST word 0x1F.

#### COM.cse

The field “cse” is a bit located at address 0x1E[18]. This bit is part of the location “COM”.

Enable CVH self-test at power-up.

#### COM.lbe

The field “lbe” is a bit located at address 0x1E[19]. This bit is part of the location “COM”.

Power-up logic BIST enable.

#### COM.lock

The field “lock” is a bit field located at address 0x1E[23:20]. This bit field is part of the location “COM”.

Lock options:

1100 Lock EEPROM writes  
0011 Lock EEPROM writes AND indirect register writes

**Location 0x1F (“CUS”)****CUS.customer**

The field “customer” is a bit field located at address 0x1F[23:0]. This bit field is part of the location “CUS”.

Customer-useable field, intended for storing data.

With certain settings, this word can be written even if EEPROM is locked. Details are given in the chapter “EEPROM write lock”.

If COM.cud = ‘1’, then, depending on COM.dur and COM.del settings, this word can be written even if EEPROM is locked. Details are given in the chapter “EEPROM write lock”.

**Location 0x20 (“LIN00”)****LIN00.Linearization Error Segment 0**

The field “Linearization Error Segment 0” is a bit field located at address 0x20[11:0]. This bit field is part of the location “LIN00”.

Correction value at segment boundary. Signed, resolution is based on LS bit. Will be subtracted from sensor angle to produce linearized angle.

- For LS = 0, range is  $\pm 22.5$  degrees.
- For LS = 1, range is  $\pm 45$  degrees.

**LIN00.Linearization Error Segment 1**

The field “Linearization Error Segment 1” is a bit field located at address 0x20[23:12]. This bit field is part of the location “LIN00”.

Correction value at segment boundary. Signed, resolution is based on LS bit. Will be subtracted from sensor angle to produce linearized angle.

- For LS = 0, range is  $\pm 22.5$  degrees.
- For LS = 1, range is  $\pm 45$  degrees.

NOTE: linearization segments 2...29 have been omitted from the datasheet for reasons of brevity.

**Location 0x2F (“LIN15”)****LIN15.Linearization Error Segment 30**

The field “Linearization Error Segment 30” is a bit field located at address 0x2F[11:0]. This bit field is part of the location “LIN15”.

Correction value at segment boundary. Signed, resolution is based on LS bit. Will be subtracted from sensor angle to produce linearized angle.

- For LS = 0, range is  $\pm 22.5$  degrees.
- For LS = 1, range is  $\pm 45$  degrees.

**LIN15.Linearization Error Segment 31**

The field “Linearization Error Segment 31” is a bit field located at address 0x2F[23:12]. This bit field is part of the location “LIN15”.

Correction value at segment boundary. Signed, resolution is based on LS bit. Will be subtracted from sensor angle to produce linearized angle.

- For LS = 0, range is  $\pm 22.5$  degrees.
- For LS = 1, range is  $\pm 45$  degrees.

**Location 0x80 (“ALV”)****ALV.alive counter**

The field “alive counter” is a bit field located at address 0x80[31:0]. This bit field is part of the location “ALV”.

Alive counter is a 32-bit counter, which increments periodically from zero after power-on or hard reset. The alive increment period is based on the EEPROM cycle\_time, which has a resolution of 8.192 ms. The alive counter can overflow. The overflow period of the counter is  $[2^{32} \times 8.192 \times (\text{cycle\_time} + 1)]$  milliseconds. At cycle\_time = 0, this period is approximately 400 days.

## SAFETY AND DIAGNOSTICS

The AAS33001 was developed in accordance to the ASIL design flow. It incorporates several diagnostics.

### Alive Counter

A 32-bit counter increments periodically from zero after power-on or hard reset. It is read via an extended read at address 0x80. The alive increment period is based on the EEPROM cycle\_time, which has a resolution of 8.192 ms.

The alive counter can overflow. The overflow period of the counter is  $[2^{32} \times 8.192 \times (\text{lpm\_cycle\_time} + 1)]$  milliseconds. At  $\text{lpm\_cycle\_time} = 0$ , this period is approximately 400 days.

### Oscillator Watchdogs

The watchdogs run constantly. These watchdogs are intended to detect gross failures of either oscillator. Logic running on clocks based on each oscillator effectively counts clock periods produced in the other clock domain and compares to expected limits.

### Logic Built-In Self-Test (LBIST)

Logic BIST is implemented to verify the integrity of the AAS33001 logic. It can be executed in parallel with the CVH self-test. LBIST is effectively a form of auto-driven scan. The logic to be tested is broken into 31 scan chains. The chains are fed in parallel by a 31-bit linear feedback shift register (LFSR) to generate pseudo-random data. The output of the scan chains are fed back into a multiple input shift register (MISR) that accumulates the shifted bits into a 31-bit signature. LBIST takes typically 30 ms to verify.

### CVH Self-Test

CVH self-test is a method of verifying the operation of the CVH transducer without applying an external magnetic field. This feature is useful for both manufacturing test and for integration debug. The CVH self-test is implemented by changing the switch configuration from the normal operating mode into a test configuration, allowing a test current to drive the CVH in place of the magnetic field. By changing the direction of the test current and by changing the elements in the CVH that are driven, the self-test circuit emulates a changing angle of magnetic field. The measured angle is monitored to determine a passing or failing device.

CVH self-test typically takes 30 ms to verify.

Self-test can be run on power-up, by setting the EEPROM field `SHA.COM.cse = 1`

Self-test can also be invoked via the serial control register by issuing the corresponding “special” command.

The test is complete when either:

- “STA.sdn” = 1 (special done) or
- “STA.cstr” = 0 (CVH self-test not running).

Failure is indicated by:

- “ERR.stf” = 1 (assuming it was cleared before test was run).

### APPLICATION INFORMATION

#### Magnetic Target Requirements

The AAS33001 is designed to operate with magnets constructed with a variety of magnetic materials, geometries, and field strengths. See Table 14 for a list of common magnet dimensions.

The AAS33001 actively measures and adapts to its magnetic environment. This allows operation throughout a large range of field strengths (recommended range is 300 to 1000 G, operation beyond this range will not result in long term damage). Due to the greater signal-to-noise ratio provided at higher field strengths, performance inherently increases with increasing field strength.

**Table 14: Target Magnet Parameters**

Magnetic Material	Diameter (mm)	Thickness (mm)
Neodymium (sintered)*	10	2.5
Neodymium (sintered)	8	3
Neodymium / SmCo	6	2.5

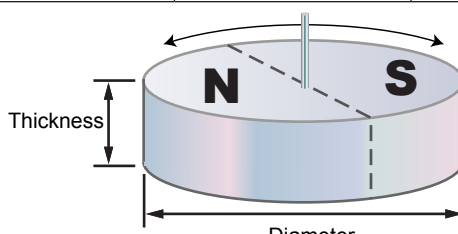
\* A sintered Neodymium magnet with 10 mm (or greater) diameter and 2.5 mm thickness is the recommended magnet for redundant applications.

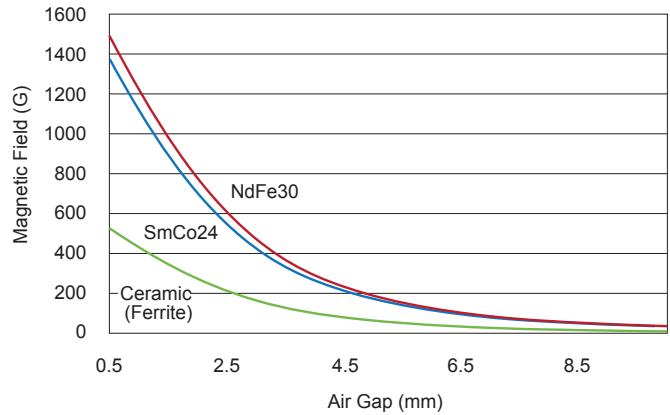

**Figure 32: Magnetic Field versus Air Gap for a magnet 6 mm in diameter and 2.5 mm thick.**

Allegro can provide similar curves for customer application magnets upon request. Allegro recommends larger magnets for applications that require optimized accuracy performance.

### Typical SPI and ABI/UVW Applications

Below, typical application diagrams for SPI and ABI are given. Programming and controlling are possible using the SPI interface and the Manchester interface. The Manchester programming

interface is useful for low pin count applications (e.g. ABI). See Manchester Interface section for details on programming with this interface.

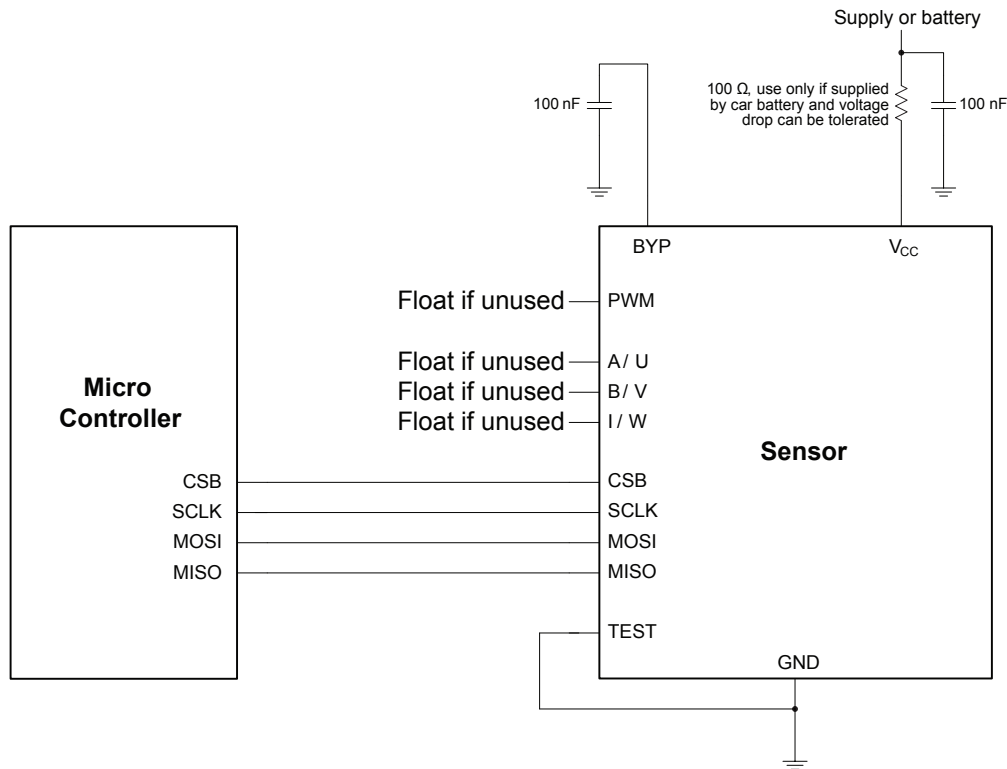
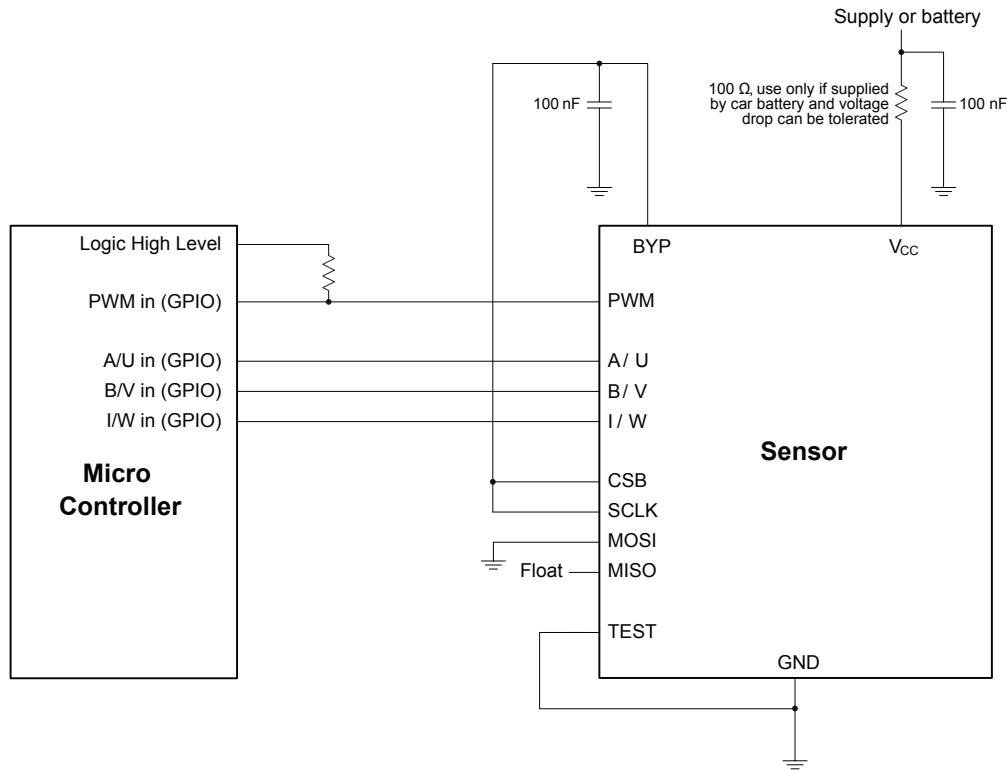

Figure 33: Typical SPI Application Diagram

Notes:

- PWM and ABI/UVW can be used in parallel to the SPI interface.

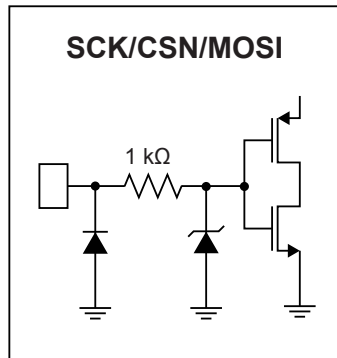
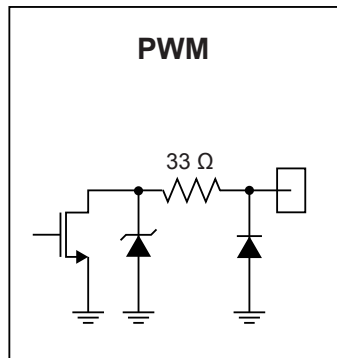
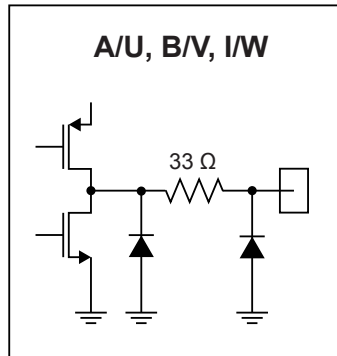

**Figure 34: Typical ABI / UVW Application Diagram**

Notes:

- PWM output can be left floating if not required. The absolute position is transferred through ABI pins after power on, so that PWM information is not needed to find the start position. The AAS33001 is different from the A1333 in this regard.
- For programming the sensor, CSB and MOSI determine the slave address. Read the Manchester Interface section for more details.
- If not needed by the host, any of the ABI outputs can be left floating. For example,
  - If only rotational frequency is needed, only pin A could be used.
  - If frequency and position is needed, but direction is always the same, only pin B and I could be used.

**I/O STRUCTURES**



## PACKAGE OUTLINE DRAWINGS

**For Reference Only – Not for Tooling Use**

(Reference MO-153 ADT)  
NOT TO SCALE

Dimensions in millimeters

Dimensions exclusive of mold flash, gate burrs, and dambar protrusions  
Exact case and lead configuration at supplier discretion within limits shown

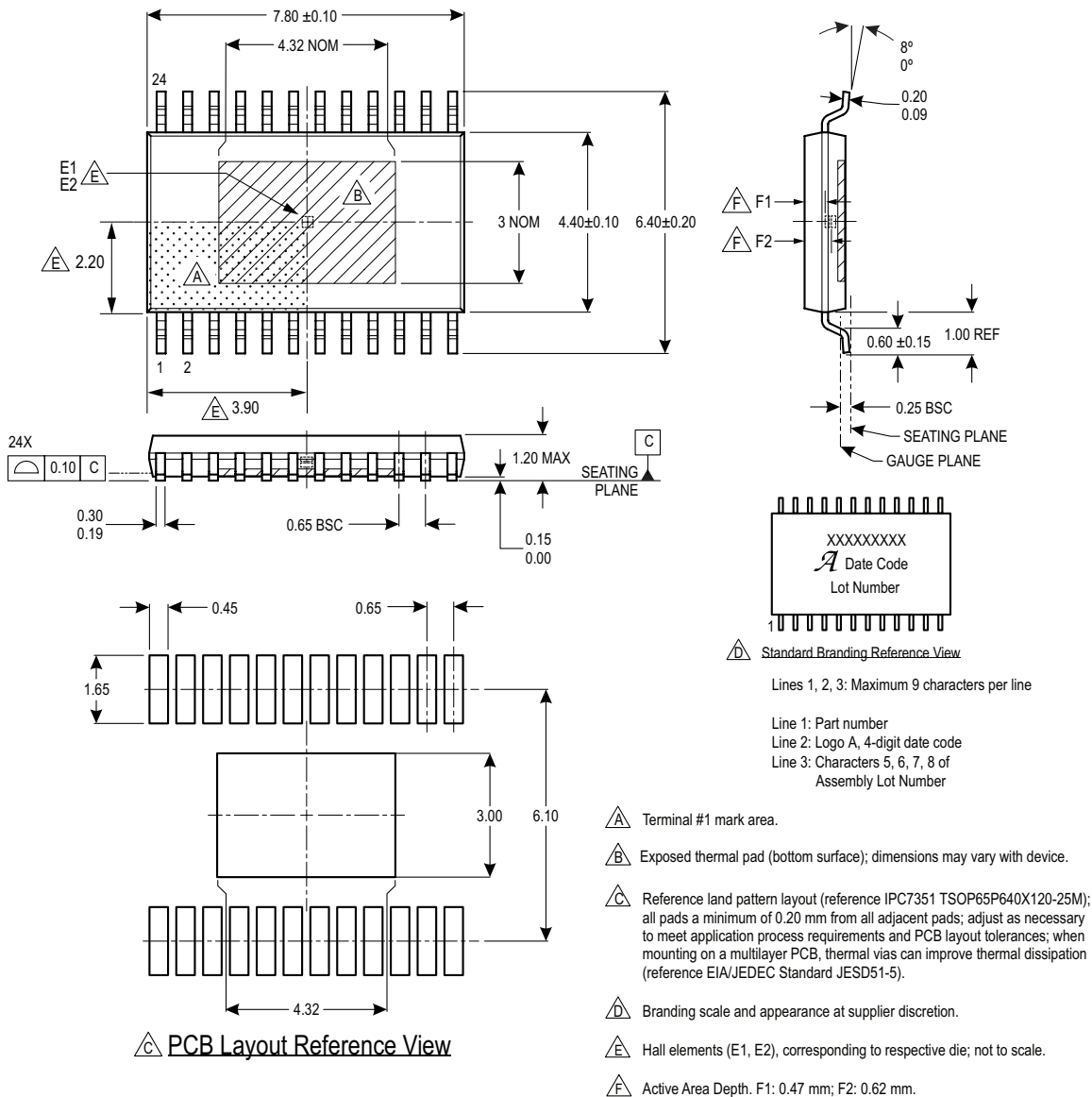

**Figure 35: Package LP, 24-Pin TSSOP with Exposed Thermal Pad**

### For Reference Only – Not for Tooling Use

(Reference DWG-2870)

Dimensions in millimeters – NOT TO SCALE

Dimensions exclusive of mold flash, gate burrs, and dambar protrusions  
Exact case and lead configuration at supplier discretion within limits shown

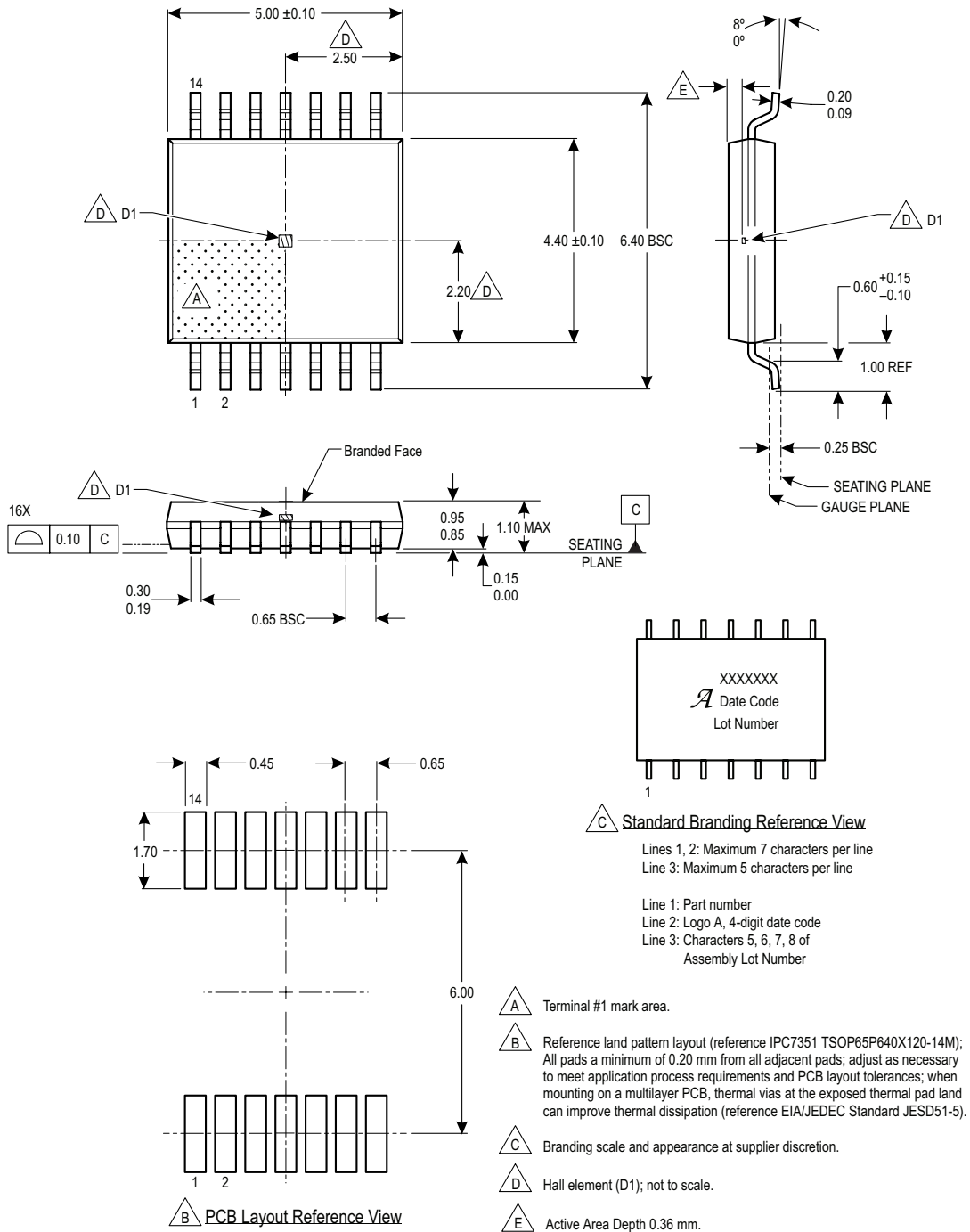

**Figure 36: Package LE, 14-Pin TSSOP**

### Revision History

Number	Date	Description
–	March 28, 2018	Initial release

Copyright ©2018, Allegro MicroSystems, LLC

Allegro MicroSystems, LLC reserves the right to make, from time to time, such departures from the detail specifications as may be required to permit improvements in the performance, reliability, or manufacturability of its products. Before placing an order, the user is cautioned to verify that the information being relied upon is current.

Allegro's products are not to be used in any devices or systems, including but not limited to life support devices or systems, in which a failure of Allegro's product can reasonably be expected to cause bodily harm.

The information included herein is believed to be accurate and reliable. However, Allegro MicroSystems, LLC assumes no responsibility for its use; nor for any infringement of patents or other rights of third parties which may result from its use.

For the latest version of this document, visit our website:

[www.allegromicro.com](http://www.allegromicro.com)

