

DMOS Microstepping Driver with Translator and Overcurrent Protection

FEATURES AND BENEFITS

- Drop-in replacement for A4988
- Proprietary Adaptive Percent Fast Decay option
- Low $R_{DS(on)}$ outputs
- Single supply
- Microstepping up to 32 microsteps per full step
- Full torque step modes
- Short-to-ground protection
- Shorted load protection
- Short-to-battery protection
- Fault output
- Low current Sleep mode, $< 10 \mu A$
- Thin profile QFN
- Thermal shutdown circuitry
- Synchronous rectification for low power dissipation
- Internal UVLO
- Crossover-current protection

APPLICATIONS

- Video Security Cameras
- Printers
- Scanners
- Robotics
- ATM
- POS

DESCRIPTION

The A5985 is a complete microstepping motor driver with built-in translator for easy operation. It is designed to operate bipolar stepper motors from full-step up to 1/32 step modes. Step modes are selectable by MSx logic inputs. It has an output drive capacity of up to 40 V and $\pm 2 A$.

A5985 introduces a proprietary Adaptive Percent Fast Decay (APFD) algorithm to optimize the current waveform over a wide range of stepper speeds and stepper motor characteristics. APFD adjusts on-the-fly the amount of fast decay during a PWM cycle to keep current ripple at a low level over the various operating conditions. This adaptive feature improves performance of the system resulting in reduced audible motor noise, reduced vibration, and increased step accuracy.

The translator is the key to the easy implementation of the A5985. Simply inputting one pulse on the STEP input drives the motor one microstep. There are no phase sequence tables, high frequency control lines, or complex interfaces to program. The A5985 interface is an ideal fit for applications where a complex microprocessor is unavailable or is overburdened.

Internal synchronous rectification control circuitry is provided to improve power dissipation during PWM operation. Internal circuit protection includes: thermal shutdown with hysteresis, undervoltage lockout (UVLO), and crossover-current protection. Special power-on sequencing is not required.

Continued on the next page...

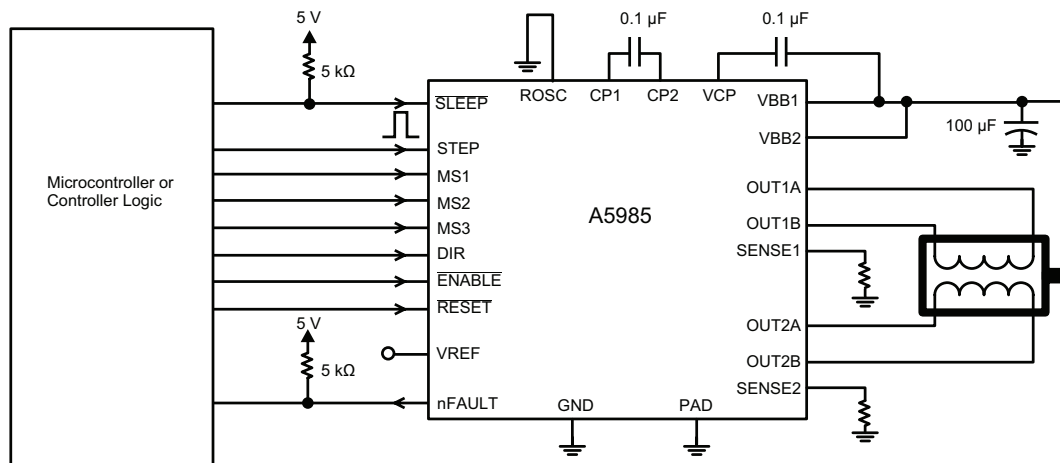

Typical Application Diagram

A5985

DMOS Microstepping Driver with Translator and Overcurrent Protection

Package:

28-contact QFN
with exposed thermal pad
5 mm × 5 mm × 0.90 mm
(ET package)

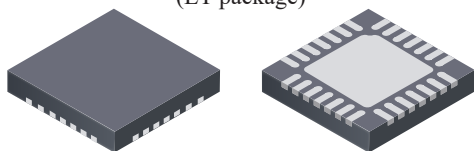

Not to scale

DESCRIPTION (continued)

The A5985 is supplied in a surface-mount QFN package (ET), 5 mm × 5 mm, with a nominal overall package height of 0.90 mm and an exposed pad for enhanced thermal dissipation. It is lead (Pb) free (suffix -T), with 100% matte-tin-plated leadframes.

SPECIFICATIONS

SELECTION GUIDE

| Part Number | Package | Packing |
|--------------|---|----------------------------|
| A5985GETTR-T | 28-contact QFN with exposed thermal pad | 1500 pieces per 7-in. reel |

ABSOLUTE MAXIMUM RATINGS

| Characteristic | Symbol | Notes | Rating | Units |
|-------------------------------|-------------|---------|------------------------|-------|
| Load Supply Voltage | V_{BB} | | 40 | V |
| Output Current | I_{OUT} | | ±2 | A |
| Logic Input Voltage | V_{IN} | | -0.3 to 6 | V |
| Motor Outputs Voltage | | | -2.0 to $V_{BB} + 2$ V | V |
| Sense Voltage | V_{SENSE} | | -0.5 to 0.5 | V |
| Reference Voltage | V_{REF} | | 5.5 | V |
| Operating Ambient Temperature | T_A | Range G | -40 to 105 | °C |
| Maximum Junction | $T_J(max)$ | | 150 | °C |
| Storage Temperature | T_{stg} | | -55 to 150 | °C |

Table of Contents

| | | | |
|--|----|--|----|
| Specifications | 2 | Protection Functions | 13 |
| Functional Block Diagram | 4 | Fault Output (nFAULT) | 13 |
| Pin-out Diagrams and Terminal List Table | 5 | Thermal or Undervoltage Fault Shutdown | 13 |
| Electrical Characteristics | 6 | Overcurrent Protection | 13 |
| Thermal Characteristics | 7 | Application Information | 14 |
| Logic Interface | 8 | Layout | 14 |
| Functional Description | 9 | Pin Circuit Diagrams | 15 |
| Device Operation | 9 | Phase Current Diagrams | 16 |
| Stepping Current Control | 9 | Full Step (100% Torque) | 16 |
| 100 Percent Torque Operation | 9 | Half Step (100% Torque) | 16 |
| Microstep Select (MSx) | 9 | Sixteenth Step | 17 |
| Reset Input (RESET) | 9 | Thirty-Secondth Step | 17 |
| Step Input (STEP) | 12 | Full Step (Modified) | 18 |
| Direction Input (DIR) | 12 | Half Step (Modified) | 18 |
| Internal PWM Current Control | 12 | Eighth Step | 19 |
| Blanking | 12 | Quarter Step | 19 |
| ROSC | 12 | Stepping Phase Tables | 20 |
| Charge Pump (CP1 and CP2) | 12 | Full Torque Modes | 20 |
| Enable Input (ENABLE) | 12 | Common Modes | 21 |
| Sleep Mode (SLEEP) | 13 | Package Outline Drawing | 25 |
| Synchronous Rectification | 13 | | |

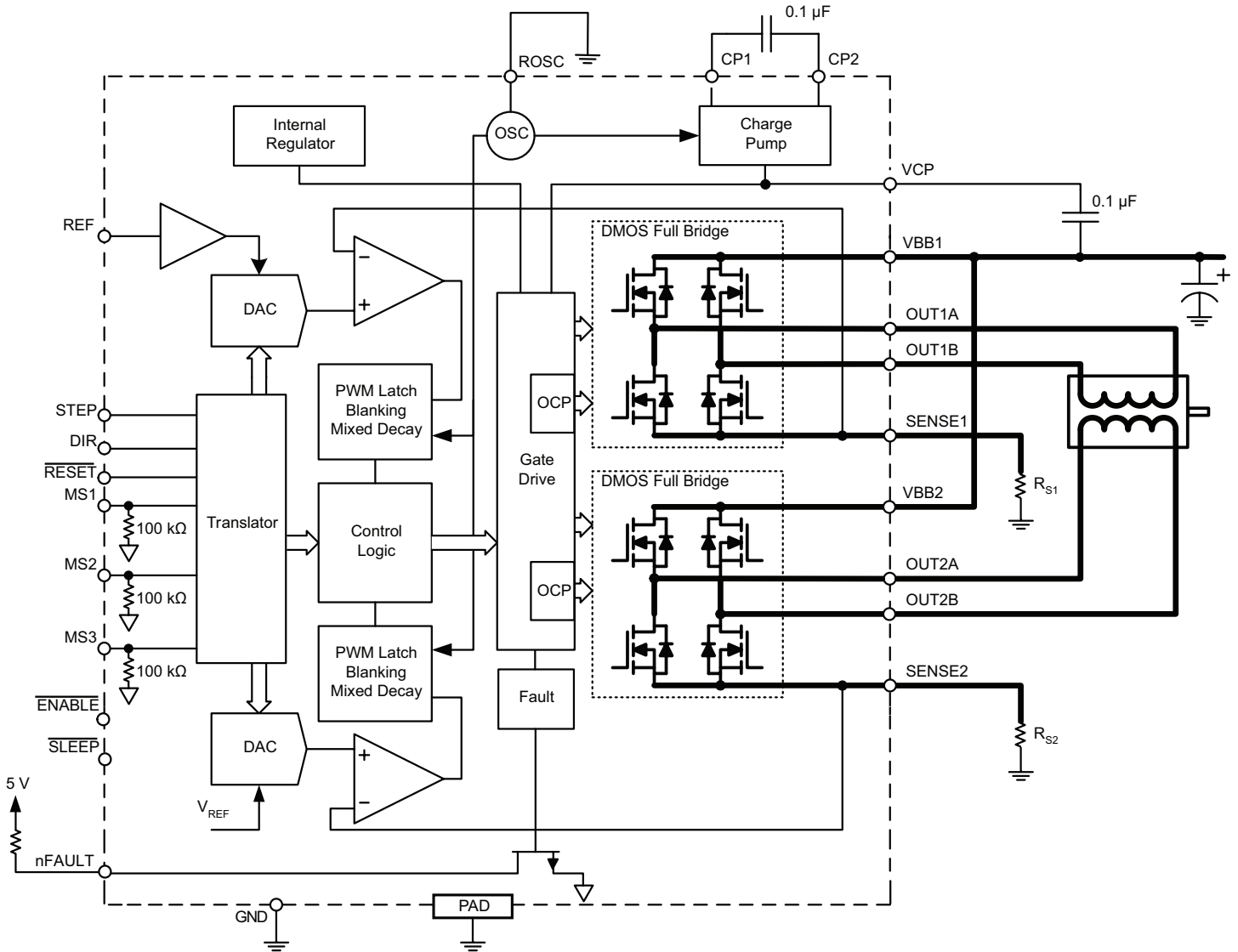

Functional Block Diagram

Pinout Diagram

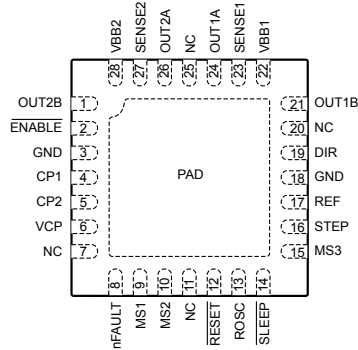

Terminal List Table

| Name | Number | Description |
|--------|---------------|---|
| CP1 | 4 | Charge pump capacitor terminal |
| CP2 | 5 | Charge pump capacitor terminal |
| DIR | 19 | Logic input |
| ENABLE | 2 | Logic input |
| GND | 3, 18 | Ground* |
| MS1 | 9 | Logic input |
| MS2 | 10 | Logic input |
| MS3 | 15 | Logic input |
| NC | 7, 11, 20, 25 | No connection |
| nFAULT | 8 | Logic output |
| OUT1A | 24 | DMOS Full Bridge 1 Output A |
| OUT1B | 21 | DMOS Full Bridge 1 Output B |
| OUT2A | 26 | DMOS Full Bridge 2 Output A |
| OUT2B | 1 | DMOS Full Bridge 2 Output B |
| REF | 17 | Gm reference voltage input |
| RESET | 12 | Logic input |
| ROSC | 13 | Timing set |
| SENSE1 | 23 | Sense resistor terminal for Bridge 1 |
| SENSE2 | 27 | Sense resistor terminal for Bridge 2 |
| SLEEP | 14 | Logic input |
| STEP | 16 | Logic input |
| VBB1 | 22 | Load supply |
| VBB2 | 28 | Load supply |
| VCP | 6 | Reservoir capacitor terminal |
| PAD | – | Exposed pad for enhanced thermal dissipation* |

*The GND pins must be tied together externally by connecting to the PAD ground plane under the device.

ELECTRICAL CHARACTERISTICS [1] valid at $T_A = 25^\circ\text{C}$, $V_{BB} = 40\text{ V}$ (unless otherwise noted)

| Characteristics | Symbol | Test Conditions | Min. | Typ. [2] | Max. | Units |
|---|-----------------|---|------|----------|----------|------------------|
| OUTPUT DRIVERS | | | | | | |
| Load Supply Voltage Range | V_{BB} | Operating | 8 | – | 40 | V |
| | | During Sleep Mode | 0 | – | 40 | V |
| Output On Resistance | $R_{DS(on)}$ | Source + Sink Driver, $I_{OUT} = -2\text{ A}$, $T_A = 25^\circ\text{C}$ | – | 640 | 860 | m Ω |
| Body Diode Forward Voltage | V_F | Source Diode, $I_F = -2\text{ A}$ | – | – | 1.4 | V |
| | | Sink Diode, $I_F = 2\text{ A}$ | – | – | 1.4 | V |
| Output Driver Slew Rate | SR_{OUT} | 10% to 90% | 50 | 100 | 150 | ns |
| Motor Supply Current | I_{BB} | $f_{PWM} < 50\text{ kHz}$ | – | 7.5 | 10 | mA |
| | | Operating, outputs disabled | – | 6.5 | 8 | mA |
| | | Sleep Mode | – | – | 10 | μA |
| CONTROL LOGIC | | | | | | |
| Logic Input Voltage | $V_{IN(1)}$ | | 2 | – | – | V |
| | $V_{IN(0)}$ | | – | – | 0.8 | V |
| | $V_{IN(SLEEP)}$ | | – | – | 0.4 | V |
| Logic Input Current | $I_{IN(1)}$ | | –20 | <1.0 | 20 | μA |
| | $I_{IN(0)}$ | | –20 | <1.0 | 20 | μA |
| Microstep Select Pins Internal Pull-Down Resistance | R_{MSx} | MS1, MS2, or MS3 pin | – | 100 | – | k Ω |
| Logic Input Hysteresis | $V_{HYS(IN)}$ | | 200 | – | 550 | mV |
| Blank Time | t_{BLANK} | | 0.7 | 1 | 1.3 | μs |
| Fixed Off-Time | t_{OFF} | ROSC = 5 V | 20 | 30 | 40 | μs |
| | | ROSC = GND | 13 | 16 | 19 | μs |
| | | $R_{OSC} = 25\text{ k}\Omega$ | 23 | 30 | 37 | μs |
| Reference Input Voltage Range | V_{REF} | | 0 | – | 4 | V |
| Reference Input Current | I_{REF} | | –3 | 0 | 3 | μA |
| Current Trip-Level Error [3] | err_I | $V_{REF} = 2\text{ V}$, $\%I_{TripMAX} = 38.27\%$ | – | – | ± 15 | % |
| | | $V_{REF} = 2\text{ V}$, $\%I_{TripMAX} = 70.71\%$ | – | – | ± 5 | % |
| | | $V_{REF} = 2\text{ V}$, $\%I_{TripMAX} = 100.00\%$ | – | – | ± 5 | % |
| Crossover Dead Time | t_{DT} | | 100 | 475 | 800 | ns |
| Fault Output Voltage | V_{RST} | nFAULT pin, $I_{OUT} = 1\text{ mA}$ | – | – | 0.5 | V |
| Fault Output Leakage Current | I_{LK} | nFAULT pin, no fault, pull-up to 5 V | – | – | 1 | μA |
| PROTECTION | | | | | | |
| Overcurrent Protection Threshold [4] | I_{OCPST} | | 2.6 | – | – | A |
| VBB UVLO | V_{BBUVLO} | V_{BB} rising | 6.3 | – | 6.85 | V |
| VBB UVLO Hysteresis | V_{BBHYS} | | – | 300 | – | mV |
| Thermal Shutdown Temperature | T_{TSD} | | – | 165 | – | $^\circ\text{C}$ |
| Thermal Shutdown Hysteresis | T_{TSDHYS} | | – | 20 | – | $^\circ\text{C}$ |

¹ For input and output current specifications, negative current is defined as coming out of (sourcing) the specified device pin.

² Typical data are for initial design estimations only, and assume optimum manufacturing and application conditions. Performance may vary for individual units, within the specified maximum and minimum limits.

³ $V_{ERR} = [(V_{REF}/8) - V_{SENSE}] / (V_{REF}/8)$.

⁴ Overcurrent protection (OCP) is tested at $T_A = 25^\circ\text{C}$ in a restricted range and guaranteed by characterization.

THERMAL CHARACTERISTICS may require derating at maximum conditions

| Characteristic | Symbol | Test Conditions* | Value | Units |
|----------------------------|-----------------|--|-------|-----------------------------|
| Package Thermal Resistance | $R_{\theta JA}$ | ET package; estimated, on 4-layer PCB, based on JEDEC standard | 32 | $^{\circ}\text{C}/\text{W}$ |

* In still air. Additional thermal information available on Allegro website.

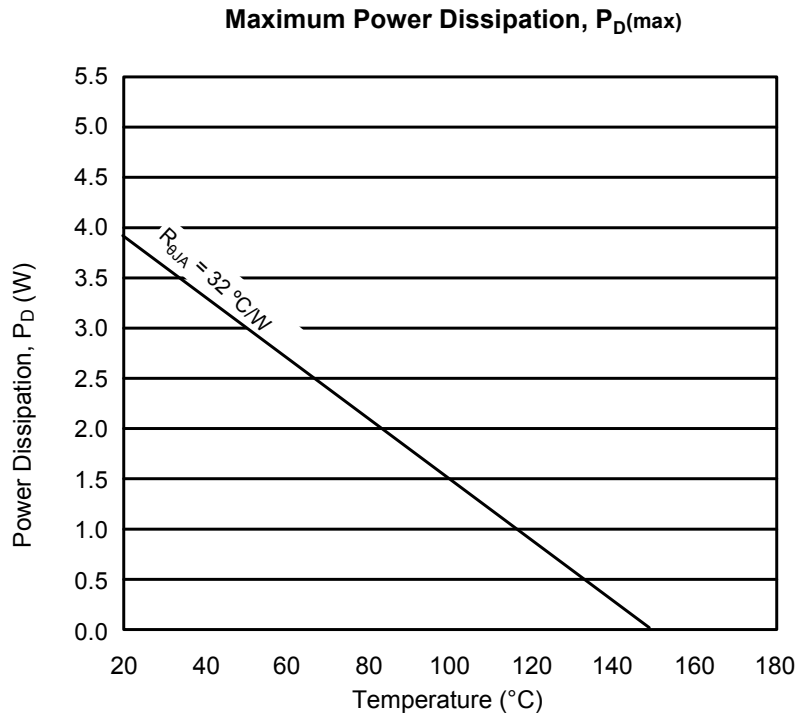

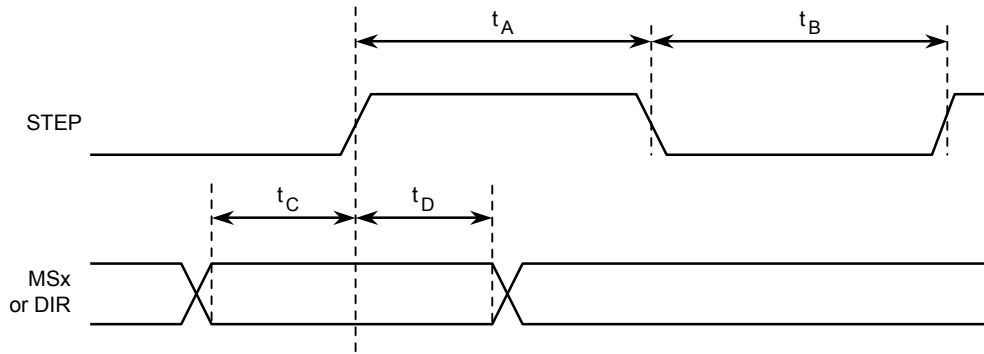

| Time Duration | Symbol | Typ. | Unit |
|----------------------------------|--------|------|---------------|
| STEP minimum, HIGH pulse width | t_A | 1 | μs |
| STEP minimum, LOW pulse width | t_B | 1 | μs |
| Setup time, input change to STEP | t_C | 400 | ns |
| Hold time, input change to STEP | t_D | 400 | ns |

Figure 1: Logic Interface Timing Diagram

Table 1: Microstep Resolution Truth Table

| MS3 | MS2 | MS1 | Microstep Resolution |
|-----|-----|-----|-------------------------|
| 0 | 0 | 0 | Full step (100% torque) |
| 0 | 0 | 1 | Half step (100% torque) |
| 0 | 1 | 0 | Sixteenth step |
| 0 | 1 | 1 | Thirty-secondth step |
| 1 | 0 | 0 | Full step (modified) |
| 1 | 0 | 1 | Half step (modified) |
| 1 | 1 | 0 | Quarter step |
| 1 | 1 | 1 | Eighth step |

FUNCTIONAL DESCRIPTION

Device Operation

The A5985 is a complete microstepping motor driver with a built-in translator for easy operation with minimal control lines. It is designed to operate bipolar stepper motors in full, half, quarter, eighth, sixteenth, or thirty-secondth step modes. The currents in each of the two output full-bridges and all of the N-channel DMOS FETs are regulated with fixed off-time PWM (pulse width modulated) control circuitry. At each step, the current for each full-bridge is set by the value of its external current-sense resistor (R_{S1} and R_{S2}), a reference voltage (V_{REF}), and the output voltage of its DAC (which in turn is controlled by the output of the translator).

At power-on or reset, the translator sets the DACs and the phase current polarity to the initial Home state (shown in the Phase Current Diagrams section), and the current regulator to Mixed Decay Mode for both phases. When a step command signal occurs on the STEP input, the translator automatically sequences the DACs to the next level and current polarity. (See Table 2 for the current-level sequence.) The microstep resolution is set by the combined effect of the MSx inputs, as shown in Table 1.

Stepping Current Control

The A5985 has two methods of current control. The first method of current control is called Adaptive Percent Fast Decay (APFD). APFD is selected by connecting pin ROSC to GND. Essentially, the IC determines the proper amount of fast decay on both rising and falling currents. By only adding fast decay when needed, the output current more accurately tracks the input command from the D-to-A converter and solves the basic problem of current discontinuity through zero when stepping at slow speeds (see Figure 4). This will result in a performance advantage for slow-speed high-resolution stepping such as with security camera applications. An additional benefit of APFD is reduced current ripple across the various operating conditions and motor characteristics.

The other method of current control utilizes slow decay mode

when current is rising and mixed decay mode (31.25%) when current is falling. This method is exactly the same as A4984 series of stepper motor drivers. This method may be desired for drop-in applications to A4984 series. The current waveform and motor performance should be identical to A4984. The mixed decay waveforms for this method are shown in Figure 2. This form of current control is selected by connecting pin ROSC to greater than 3 V or by connecting a resistor from ROSC to GND. The Resistor option is used to adjust the off-time as desired (see ROSC section).

100 Percent Torque Operation

In full- and half-step modes, the device can be programmed so both phases are at $\pm 100\%$ current levels for full step mode, and either $\pm 100\%$ or 0% for half step mode.

Microstep Select (MSx)

The microstep resolution is set by the voltage on logic inputs MSx, as shown in Table 1. Each MSx pin has an internal 100 k Ω pull-down resistance. When changing the step mode the change does not take effect until the next STEP rising edge.

If the step mode is changed without a translator reset, and absolute position must be maintained, it is important to change the step mode at a step position that is common to both step modes in order to avoid missing steps. When the device is powered down, or reset due to TSD or an over current event the translator is set to the home position which is by default common to all step modes.

Reset Input ($\overline{\text{RESET}}$)

The $\overline{\text{RESET}}$ input sets the translator to a predefined Home state (shown in Phase Current Diagrams section), and turns off all of the FET outputs. All STEP inputs are ignored until the $\overline{\text{RESET}}$ input is set to high.

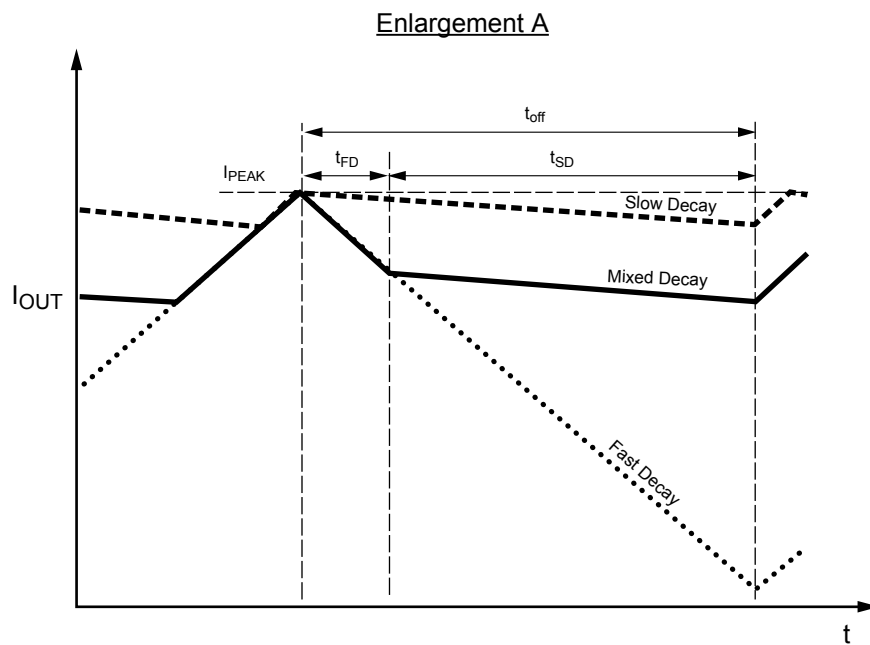
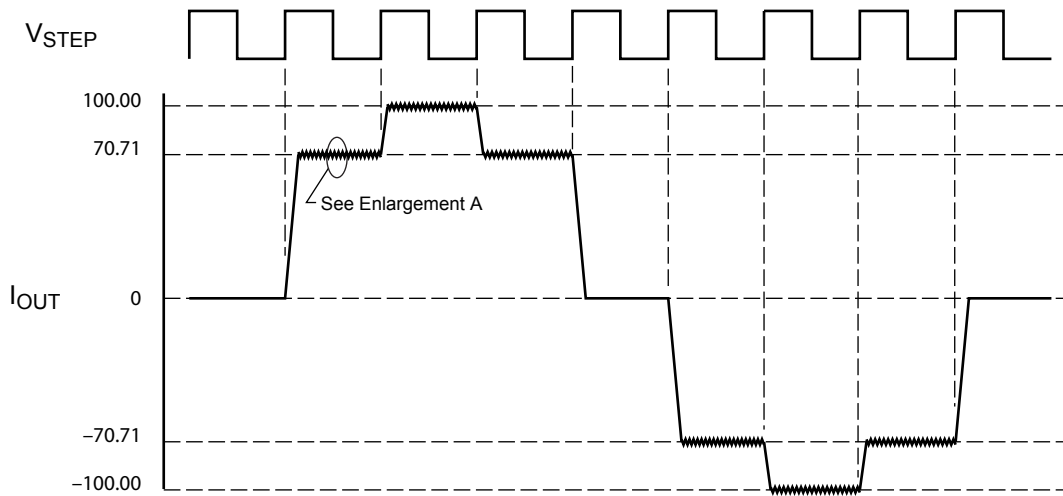

| Symbol | Characteristic |
|------------|------------------------|
| t_{off} | Device fixed off-time |
| I_{PEAK} | Maximum output current |
| t_{SD} | Slow decay interval |
| t_{FD} | Fast decay interval |
| I_{OUT} | Device output current |

Figure 2: Current Decay Modes Timing Chart

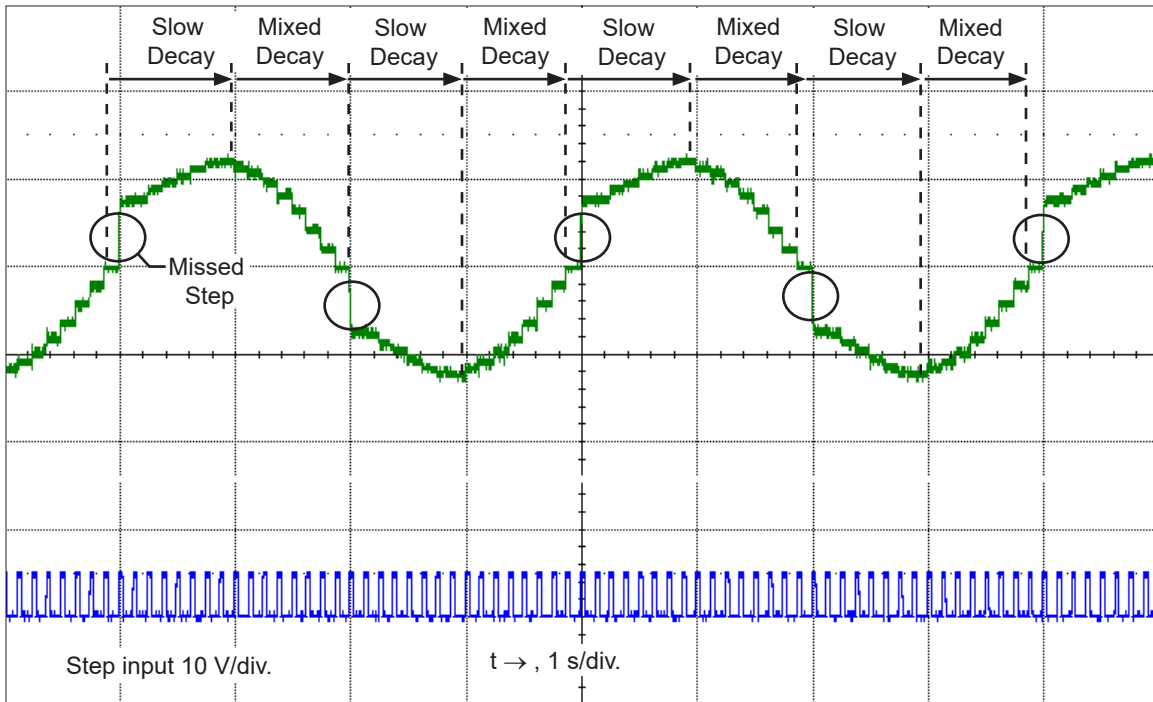

Figure 3: Missed Steps in Low-Speed Microstepping

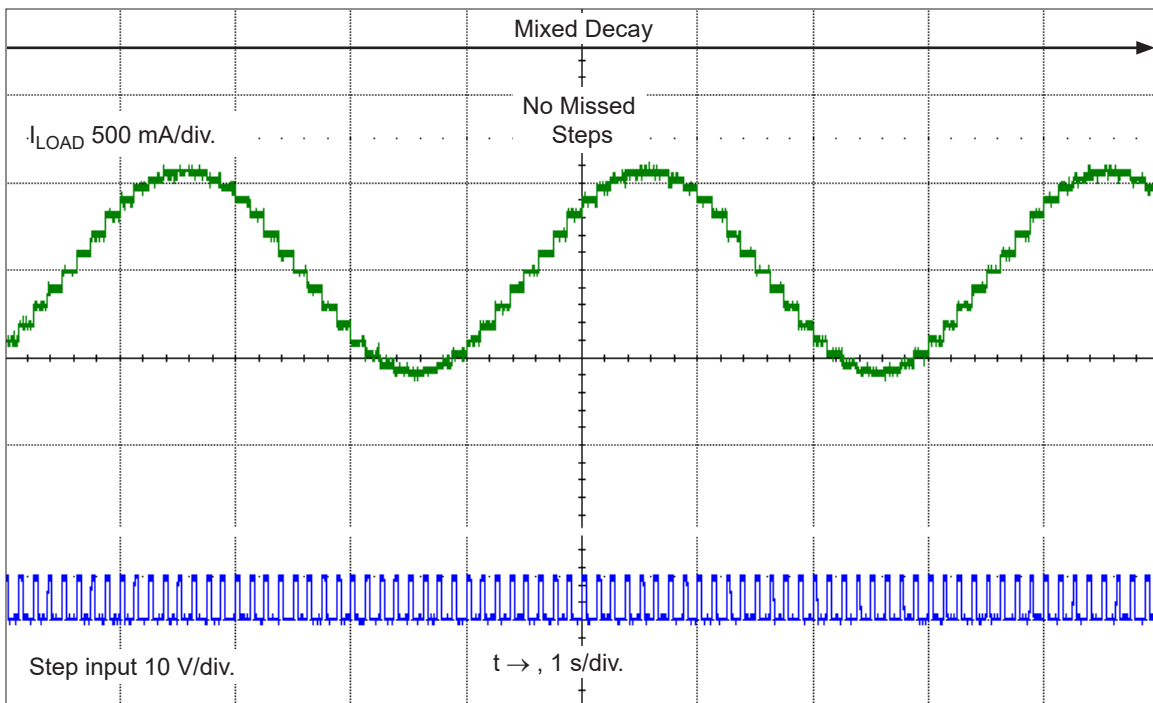

Figure 4: Continuous Stepping Using APFD (ROSC Pin Grounded)

Step Input (STEP)

A low-to-high transition on the STEP input sequences the translator and advances the motor one increment. The translator controls the input to the DACs and the direction of current flow in each winding. The size of the increment is determined by the combined state of the MSx inputs.

Direction Input (DIR)

This determines the direction of rotation of the motor. Setting to logic high and logic low set opposite rotational directions. Changes to this input do not take effect until the next STEP input rising edge. Refer to Phase Current diagrams (Figures 10 to 17). For DIR = LOW, currents change sequentially clockwise around the circle. For DIR = HIGH, counterclockwise.

Internal PWM Current Control

Each full-bridge is controlled by a fixed off-time PWM current control circuit that limits the load current to a desired value, I_{TRIP} . Initially, a diagonal pair of source and sink FET outputs are enabled and current flows through the motor winding and the current sense resistor, R_{Sx} . When the voltage across R_{Sx} equals the DAC output voltage, the current sense comparator resets the PWM latch. The latch then turns off either the source FET (when in Slow decay mode) or the sink and source FETs (when in Mixed decay mode).

The maximum value of current limiting is set by the selection of R_{Sx} and the voltage at the VREF pin. The transconductance function is approximated by the maximum value of current limiting, $I_{TripMAX}$ (A), which is set by

$$I_{TripMAX} = V_{REF} / (8 \times R_S)$$

where R_S is the resistance of the sense resistor (Ω) and V_{REF} is the input voltage on the REF pin (V).

The DAC output reduces the V_{REF} output to the current sense comparator in precise steps, such that

$$I_{trip} = (\%I_{TripMAX} / 100) \times I_{TripMAX}$$

(See table 2 for $\%I_{TripMAX}$ at each step.)

It is critical that the maximum rating (0.5 V) on the SENSE1 and SENSE2 pins is not exceeded.

Blanking

This function blanks the output of the current sense comparators when the outputs are switched by the internal current control circuitry. The comparator outputs are blanked to prevent false overcurrent detection due to reverse recovery currents of the clamp diodes, and switching transients related to the capacitance of the load. The blank time, t_{BLANK} (μs), is approximately

$$t_{BLANK} \approx 1 \mu s$$

ROSC

The configuration of the ROSC terminal determines both the method of current control as well as the fixed off-time (t_{OFF}).

| ROSC | Decay Mode | t_{OFF} |
|---------------------------|--|----------------------|
| GND | APFD (Adaptive Percent Fast Decay Mode) | 16 μs |
| Resistor to GND | Slow Decay Rising Current Steps Mixed Decay Falling Current Steps | ROSC/825 (μs) |
| Pulled Up to > 3 V Supply | Slow Decay Rising Current Steps Mixed Decay Falling Current Steps | 30 μs |

Charge Pump (CP1 and CP2)

The charge pump is used to generate a gate supply greater than that of VBB for driving the source-side FET gates. A 0.1 μF ceramic capacitor, should be connected between CP1 and CP2. In addition, a 0.1 μF ceramic capacitor is required between VCP and VBB, to act as a reservoir for operating the high-side FET gates.

Capacitor values should be Class 2 dielectric $\pm 15\%$ maximum, or tolerance R, according to EIA (Electronic Industries Alliance) specifications.

Enable Input (\overline{ENABLE})

This input turns on or off all of the FET outputs. When set to a logic high, the outputs are disabled. When set to a logic low, the internal control enables the outputs as required. The translator inputs STEP, DIR, and MSx, as well as the internal sequencing logic, all remain active, independent of the \overline{ENABLE} input state.

Sleep Mode (\overline{SLEEP})

To minimize power consumption when the motor is not in use, SLEEP disables much of the internal circuitry including the

output FETs, current regulator, and charge pump. A logic low on the $\overline{\text{SLEEP}}$ pin puts the A5985 into Sleep mode. A logic high allows normal operation, as well as start-up (at which time the A5985 drives the motor to the Home microstep position). When emerging from Sleep mode, in order to allow the charge pump to stabilize, provide a delay of 1 ms before issuing a Step command.

Synchronous Rectification

When a PWM-off cycle is triggered by an internal fixed-off time cycle, load current recirculates according to the decay mode selected by the control logic. This synchronous rectification feature turns on the appropriate FETs during current decay, and effectively shorts out the body diodes with the low FET $R_{\text{DS(on)}}$. This reduces power dissipation significantly and can eliminate the need for external Schottky diodes in many applications. Synchronous rectification turns off when the load current approaches zero (0 A), preventing reversal of the load current.

Protection Functions

FAULT OUTPUT (nFAULT)

An open drain fault output is provided to notify the user if the IC has been disabled due to an OCP event. If an OCP event is triggered the device will be disabled and the outputs will be latched off. The active low nFAULT output will be enabled. The latch can be reset by commanding $\overline{\text{SLEEP}}$ or $\overline{\text{RESET}}$ low, or by bringing VBB below its UVLO threshold.

THERMAL OR UNDERVOLTAGE FAULT SHUTDOWN

In the event of a fault, overtemperature (excess T_j) or an undervoltage (on VCP), the FET outputs of the A5985 are disabled until the fault condition is removed. At power-on, the UVLO (undervoltage lockout) circuit disables the FET outputs and resets the translator to the Home state.

OVERCURRENT PROTECTION

A current monitor will protect the IC from damage due to output shorts. If a short is detected, the IC will latch the fault and disable the outputs. The fault latch can only be cleared by coming out of Sleep mode or by cycling the power to VBB. During OCP events, Absolute Maximum Ratings may be exceeded for a short period of time before the device latches (see Figure 5).

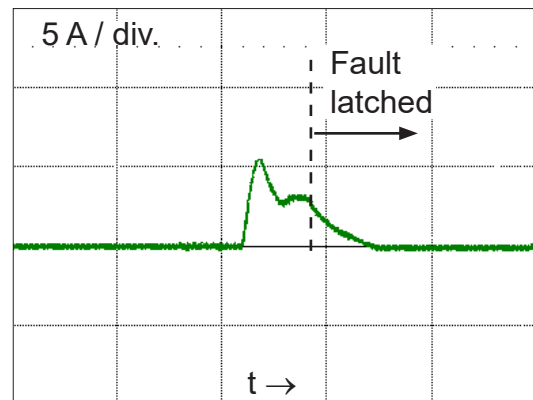

Figure 5: Overcurrent Event

APPLICATION INFORMATION

Layout

The printed circuit board should use a heavy groundplane. For optimum electrical and thermal performance, the A5985 must be soldered directly onto the board. On the underside of the A5985 package is an exposed pad, which provides a path for enhanced thermal dissipation. The thermal pad should be soldered directly to an exposed surface on the PCB. Thermal vias are used to transfer heat to other layers of the PCB (see Figure 6).

In order to minimize the effects of ground bounce and offset issues, it is important to have a low impedance single-point ground, known as a *star ground*, located very close to the device. By making the connection between the pad and the ground plane directly under the A5985, that area becomes an ideal location for a star ground point. A low-impedance ground will prevent ground bounce during high-current operation and ensure that the supply voltage remains stable at the input terminal.

The two input capacitors should be placed in parallel, and as close to the device supply pins as possible (see Figure 8). The ceramic capacitor (C7) should be closer to the pins than the bulk capacitor (C2). This is necessary because the ceramic capacitor will be responsible for delivering the high-frequency current components.

The sense resistors, RSx, should have a very low-impedance path to ground, because they must carry a large current while supporting very accurate voltage measurements by the current sense comparators. Long ground traces will cause additional voltage drops, adversely affecting the ability of the comparators to accurately measure the current in the windings. The SENSEx pins have very short traces to the RSx resistors and very thick, low-impedance traces directly to the star ground underneath the device. If possible, there should be no other components on the sense circuits.

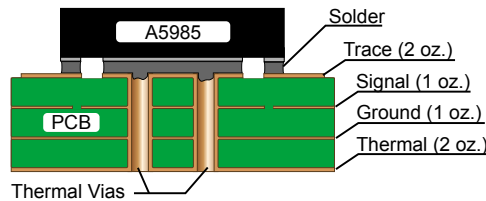

Figure 6: Soldering Cross-Section

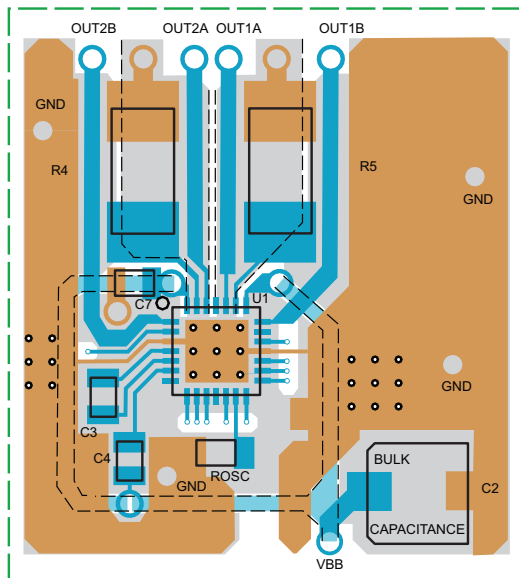

Figure 7: ET Package Circuit Layout

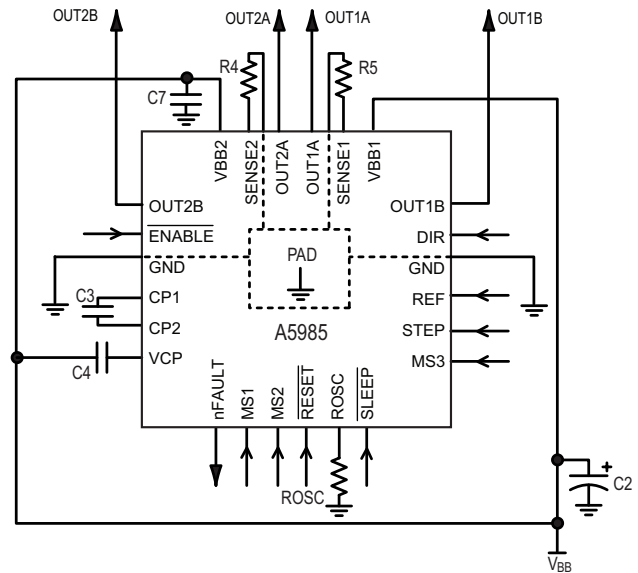

Figure 8: ET Package Typical Application

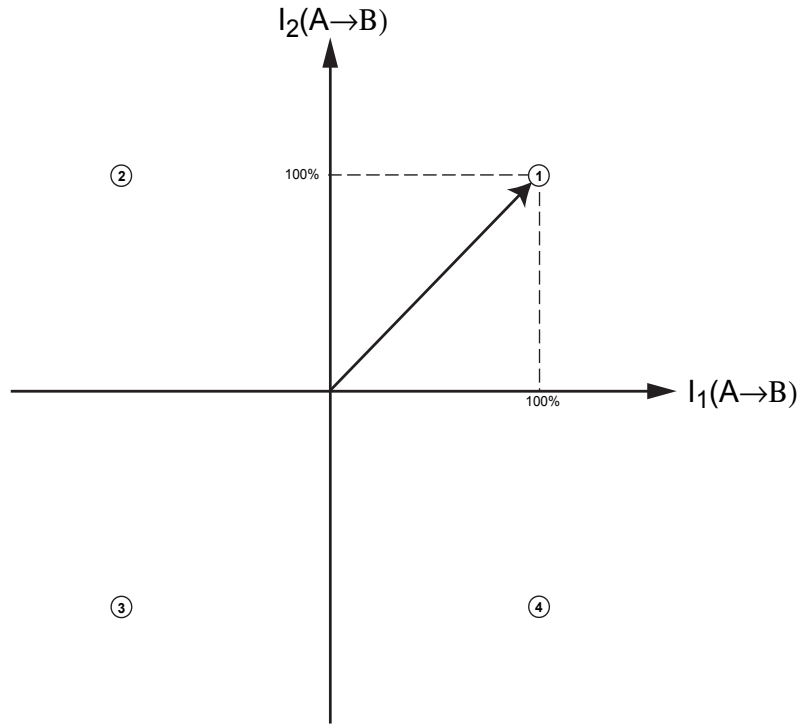

Figure 10: Full Step (100% Torque)
MSX pins = 000. See Table 2 for step number detail

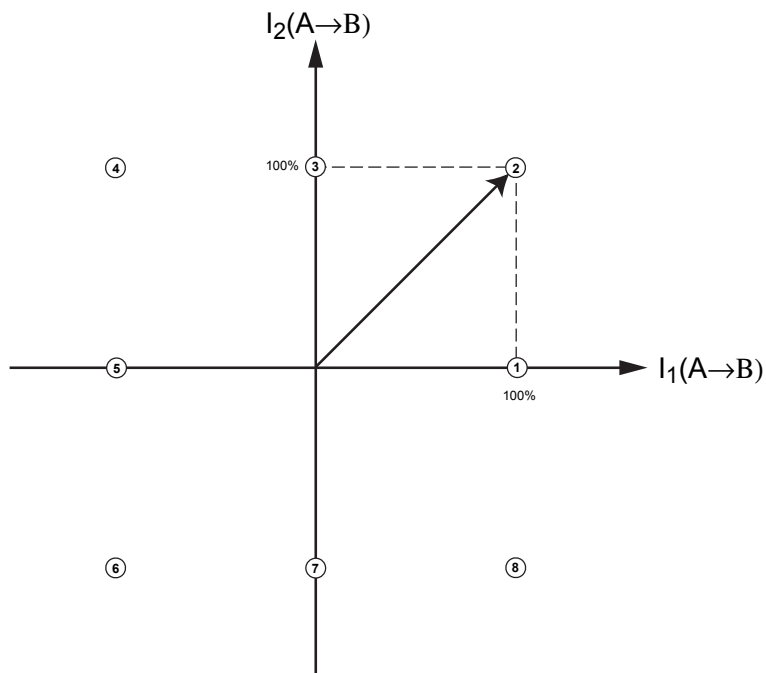

Figure 11: Half Step (100% Torque)
MSX pins = 001. See Table 2 for step number detail

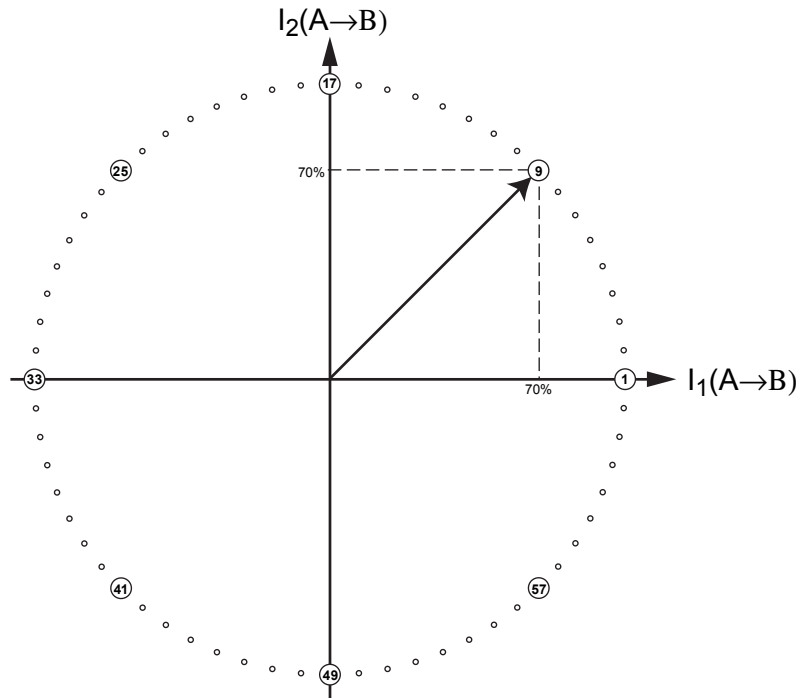

Figure 12: Sixteenth Step
MSX pins = 010. See Table 3 for step number detail

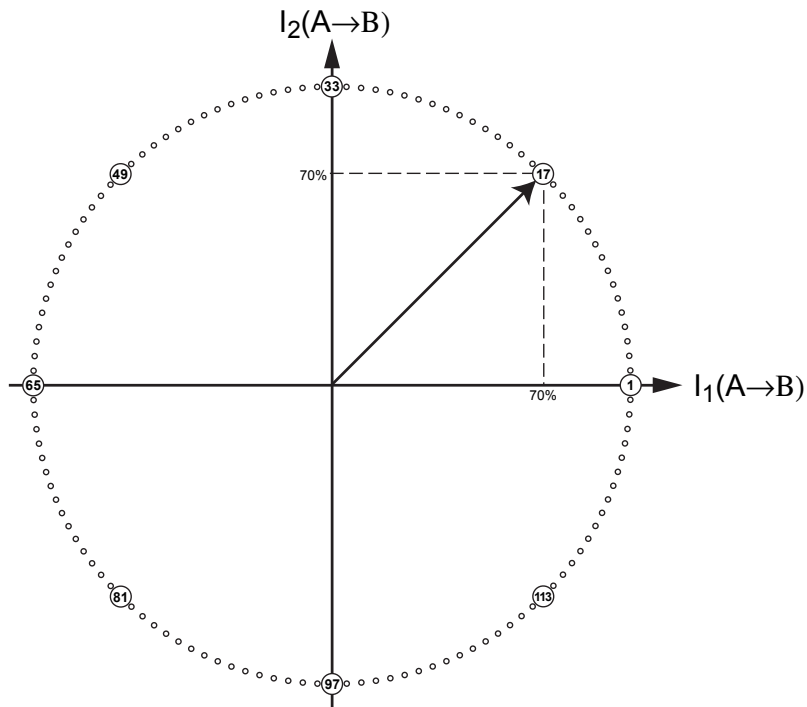

Figure 13: Thirty-Second Step
MSX pins = 011. See Table 3 for step number detail

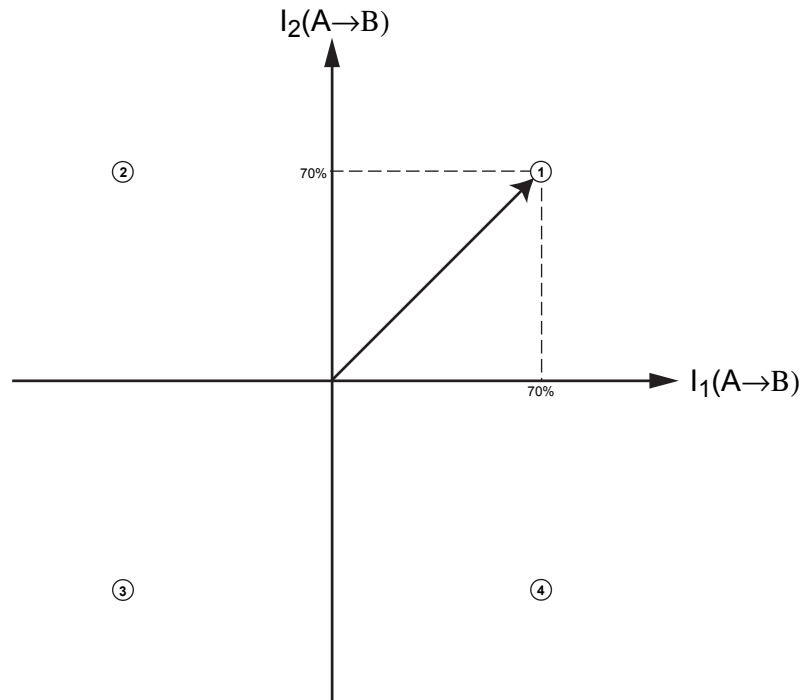

Figure 14: Full Step (70% Torque)
MSX pins = 100. See Table 3 for step number detail

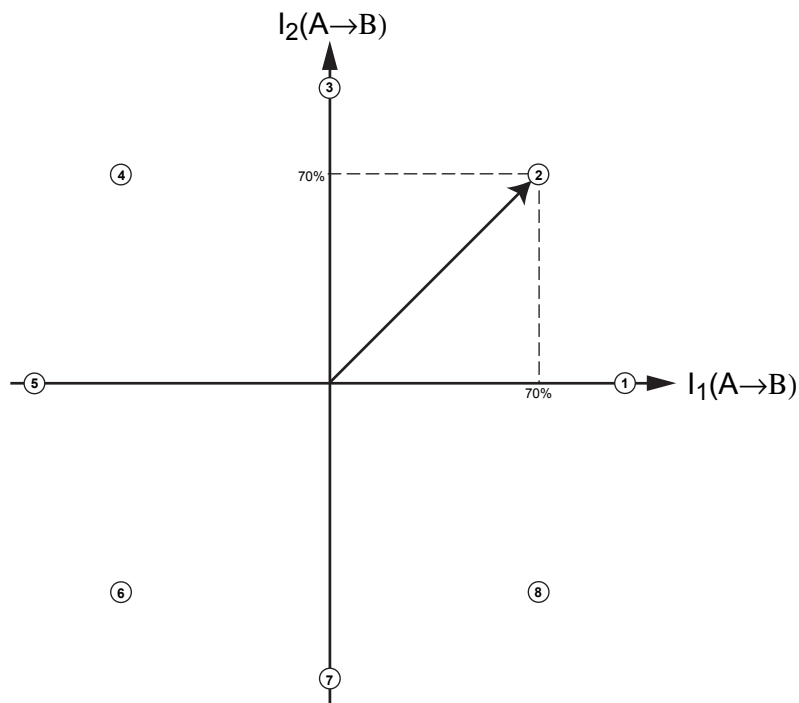

Figure 15: Half Step (70% Torque)
MSX pins = 101. See Table 3 for step number detail

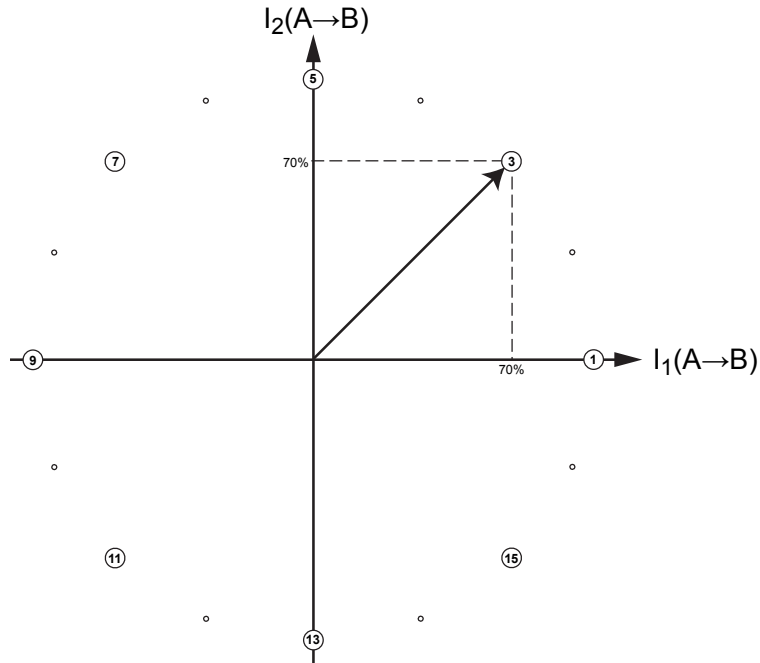

Figure 16: Quarter Step
MSX pins = 110. See Table 3 for step number detail

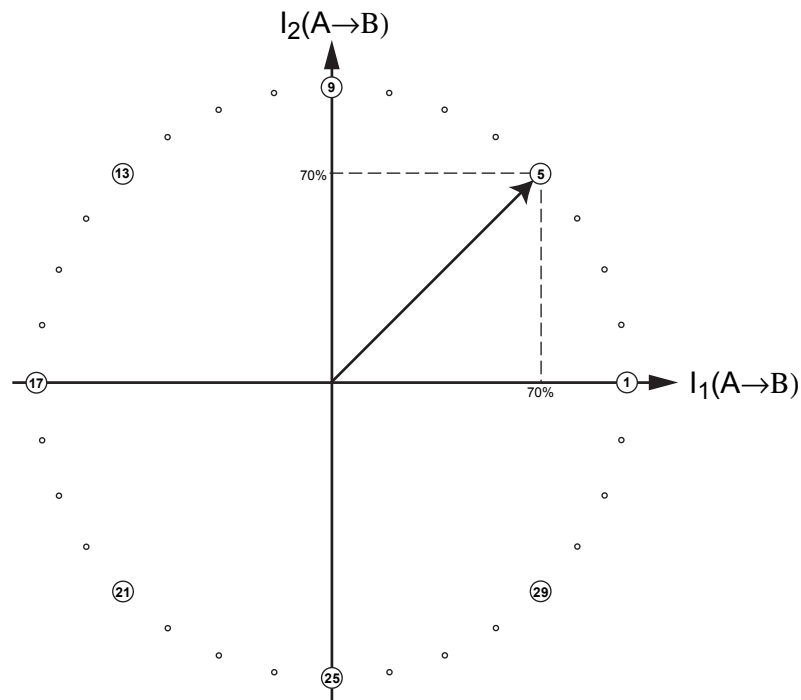

Figure 17: Eighth Step
MSX pins = 111. See Table 3 for step number detail

Stepping Phase Tables**Table 2: Stepping Phase Table, Full Torque Modes**

| Full (100%) | Half Step (100%) | Angle | Winding Current 1 (%) | Winding Current 2 (%) |
|-------------|------------------|-------|-----------------------|-----------------------|
| | 1 | 0 | 100 | 0 |
| 1 | 2 | 45 | 100 | 100 |
| | 3 | 90 | 0 | 100 |
| 2 | 4 | 135 | -100 | 100 |
| | 5 | 180 | -100 | 0 |
| 3 | 6 | 225 | -100 | -100 |
| | 7 | 270 | 0 | -100 |
| 4 | 8 | 315 | 100 | -100 |

Table 3: Stepping Phase Table, Common Modes

| Full (70%) | Half (70%) | 1/4 Step | 1/8 Step | 1/16 Step | 1/32 Step | Angle | Winding Current 1 (%) | Winding Current 2 (%) |
|------------|------------|----------|----------|-----------|-----------|-------|-----------------------|-----------------------|
| | 1 | 1 | 1 | 1 | 1 | 0 | 100 | 0 |
| | | | | | 2 | 2.8 | 100 | 5 |
| | | | | 2 | 3 | 5.6 | 100 | 10 |
| | | | | | 4 | 8.4 | 99 | 15 |
| | | | 2 | 3 | 5 | 11.3 | 98 | 20 |
| | | | | | 6 | 14.1 | 97 | 24 |
| | | | | 4 | 7 | 16.9 | 96 | 29 |
| | | | | | 8 | 19.7 | 94 | 34 |
| | | 2 | 3 | 5 | 9 | 22.5 | 92 | 38 |
| | | | | | 10 | 25.3 | 90 | 43 |
| | | | | 6 | 11 | 28.1 | 88 | 47 |
| | | | 4 | 7 | 13 | 33.8 | 83 | 56 |
| | | | | | 14 | 36.6 | 80 | 60 |
| | | | | 8 | 15 | 39.4 | 77 | 63 |
| | | | | | 16 | 42.2 | 74 | 67 |
| 1 | 2 | 3 | 5 | 9 | 17 | 45 | 71 | 71 |
| | | | | | 18 | 47.8 | 67 | 74 |
| | | | | 10 | 19 | 50.6 | 63 | 77 |
| | | | | | 20 | 53.4 | 60 | 80 |
| | | | 6 | 11 | 21 | 56.3 | 55 | 83 |
| | | | | | 22 | 59.1 | 51 | 86 |
| | | | | 12 | 23 | 61.9 | 47 | 88 |
| | | | | | 24 | 64.7 | 43 | 90 |
| | | 4 | 7 | 13 | 25 | 67.5 | 38 | 92 |
| | | | | | 26 | 70.3 | 34 | 94 |
| | | | | 14 | 27 | 73.1 | 29 | 96 |
| | | | | | 28 | 75.9 | 24 | 97 |
| | | | 8 | 15 | 29 | 78.8 | 19 | 98 |
| | | | | | 30 | 81.6 | 15 | 99 |
| | | | | 16 | 31 | 84.4 | 10 | 100 |
| | | | | | 32 | 87.2 | 5 | 100 |
| | 3 | 5 | 9 | 17 | 33 | 90 | 0 | 100 |

Continued on the next page...

Stepping Phase Table, Common Modes (continued)

| Full (70%) | Half (70%) | 1/4 Step | 1/8 Step | 1/16 Step | 1/32 Step | Angle | Winding Current 1 (%) | Winding Current 2 (%) |
|------------|------------|----------|----------|-----------|-----------|-------|-----------------------|-----------------------|
| | | | | | 34 | 92.8 | -5 | 100 |
| | | | | 18 | 35 | 95.6 | -10 | 100 |
| | | | | | 36 | 98.4 | -15 | 99 |
| | | | 10 | 19 | 37 | 101.3 | -20 | 98 |
| | | | | | 38 | 104.1 | -24 | 97 |
| | | | | 20 | 39 | 106.9 | -29 | 96 |
| | | | | | 40 | 109.7 | -34 | 94 |
| | | 6 | 11 | 21 | 41 | 112.5 | -38 | 92 |
| | | | | | 42 | 115.3 | -43 | 90 |
| | | | | 22 | 43 | 118.1 | -47 | 88 |
| | | | | | 44 | 120.9 | -51 | 86 |
| | | | 12 | 23 | 45 | 123.8 | -56 | 83 |
| | | | | | 46 | 126.6 | -60 | 80 |
| | | | | 24 | 47 | 129.4 | -63 | 77 |
| | | | | | 48 | 132.2 | -67 | 74 |
| 2 | 4 | 7 | 13 | 25 | 49 | 135 | -71 | 71 |
| | | | | | 50 | 137.8 | -74 | 67 |
| | | | | 26 | 51 | 140.6 | -77 | 63 |
| | | | | | 52 | 143.4 | -80 | 60 |
| | | | 14 | 27 | 53 | 146.3 | -83 | 55 |
| | | | | | 54 | 149.1 | -86 | 51 |
| | | | | 28 | 55 | 151.9 | -88 | 47 |
| | | | | | 56 | 154.7 | -90 | 43 |
| | | 8 | 15 | 29 | 57 | 157.5 | -92 | 38 |
| | | | | | 58 | 160.3 | -94 | 34 |
| | | | | 30 | 59 | 163.1 | -96 | 29 |
| | | | | | 60 | 165.9 | -97 | 24 |
| | | | 16 | 31 | 61 | 168.8 | -98 | 19 |
| | | | | | 62 | 171.6 | -99 | 15 |
| | | | | 32 | 63 | 174.4 | -100 | 10 |
| | | | | | 64 | 177.2 | -100 | 5 |
| | 5 | 9 | 17 | 33 | 65 | 180 | -100 | 0 |
| | | | | | 66 | 182.8 | -100 | -5 |

Continued on the next page...

Stepping Phase Table, Common Modes (continued)

| Full (70%) | Half (70%) | 1/4 Step | 1/8 Step | 1/16 Step | 1/32 Step | Angle | Winding Current 1 (%) | Winding Current 2 (%) |
|------------|------------|----------|----------|-----------|-----------|-------|-----------------------|-----------------------|
| | | | | 34 | 67 | 185.6 | -100 | -10 |
| | | | | | 68 | 188.4 | -99 | -15 |
| | | | 18 | 35 | 69 | 191.3 | -98 | -20 |
| | | | | | 70 | 194.1 | -97 | -24 |
| | | | | 36 | 71 | 196.9 | -96 | -29 |
| | | | | | 72 | 199.7 | -94 | -34 |
| | | 10 | 19 | 37 | 73 | 202.5 | -92 | -38 |
| | | | | | 74 | 205.3 | -90 | -43 |
| | | | | 38 | 75 | 208.1 | -88 | -47 |
| | | | | | 76 | 210.9 | -86 | -51 |
| | | | 20 | 39 | 77 | 213.8 | -83 | -56 |
| | | | | | 78 | 216.6 | -80 | -60 |
| | | | | 40 | 79 | 219.4 | -77 | -63 |
| | | | | | 80 | 222.2 | -74 | -67 |
| 3 | 6 | 11 | 21 | 41 | 81 | 225 | -71 | -71 |
| | | | | | 82 | 227.8 | -67 | -74 |
| | | | | 42 | 83 | 230.6 | -63 | -77 |
| | | | | | 84 | 233.4 | -60 | -80 |
| | | | 22 | 43 | 85 | 236.3 | -55 | -83 |
| | | | | | 86 | 239.1 | -51 | -86 |
| | | | | 44 | 87 | 241.9 | -47 | -88 |
| | | | | | 88 | 244.7 | -43 | -90 |
| | | 12 | 23 | 45 | 89 | 247.5 | -38 | -92 |
| | | | | | 90 | 250.3 | -34 | -94 |
| | | | | 46 | 91 | 253.1 | -29 | -96 |
| | | | | | 92 | 255.9 | -24 | -97 |
| | | | 24 | 47 | 93 | 258.8 | -19 | -98 |
| | | | | | 94 | 261.6 | -15 | -99 |
| | | | | 48 | 95 | 264.4 | -10 | -100 |
| | | | | | 96 | 267.2 | -5 | -100 |
| | 7 | 13 | 25 | 49 | 97 | 270 | 0 | -100 |
| | | | | | 98 | 272.8 | 5 | -100 |

Continued on the next page...

Stepping Phase Table, Common Modes (continued)

| Full (70%) | Half (70%) | 1/4 Step | 1/8 Step | 1/16 Step | 1/32 Step | Angle | Winding Current 1 (%) | Winding Current 2 (%) |
|------------|------------|----------|----------|-----------|-----------|-------|-----------------------|-----------------------|
| | | | | 50 | 99 | 275.6 | 10 | -100 |
| | | | | | 100 | 278.4 | 15 | -99 |
| | | | 26 | 51 | 101 | 281.3 | 20 | -98 |
| | | | | | 102 | 284.1 | 24 | -97 |
| | | | | 52 | 103 | 286.9 | 29 | -96 |
| | | | | | 104 | 289.7 | 34 | -94 |
| | | 14 | 27 | 53 | 105 | 292.5 | 38 | -92 |
| | | | | | 106 | 295.3 | 43 | -90 |
| | | | | 54 | 107 | 298.1 | 47 | -88 |
| | | | | | 108 | 300.9 | 51 | -86 |
| | | | 28 | 55 | 109 | 303.8 | 56 | -83 |
| | | | | | 110 | 306.6 | 60 | -80 |
| | | | | 56 | 111 | 309.4 | 63 | -77 |
| | | | | | 112 | 312.2 | 67 | -74 |
| 4 | 8 | 15 | 29 | 57 | 113 | 315 | 71 | -71 |
| | | | | | 114 | 317.8 | 74 | -67 |
| | | | | 58 | 115 | 320.6 | 77 | -63 |
| | | | | | 116 | 323.4 | 80 | -60 |
| | | | 30 | 59 | 117 | 326.3 | 83 | -55 |
| | | | | | 118 | 329.1 | 86 | -51 |
| | | | | 60 | 119 | 331.9 | 88 | -47 |
| | | | | | 120 | 334.7 | 90 | -43 |
| | | 16 | 31 | 61 | 121 | 337.5 | 92 | -38 |
| | | | | | 122 | 340.3 | 94 | -34 |
| | | | | 62 | 123 | 343.1 | 96 | -29 |
| | | | | | 124 | 345.9 | 97 | -24 |
| | | | 32 | 63 | 125 | 348.8 | 98 | -19 |
| | | | | | 126 | 351.6 | 99 | -15 |
| | | | | 64 | 127 | 354.4 | 100 | -10 |
| | | | | | 128 | 357.2 | 100 | -5 |

PACKAGE OUTLINE DRAWING

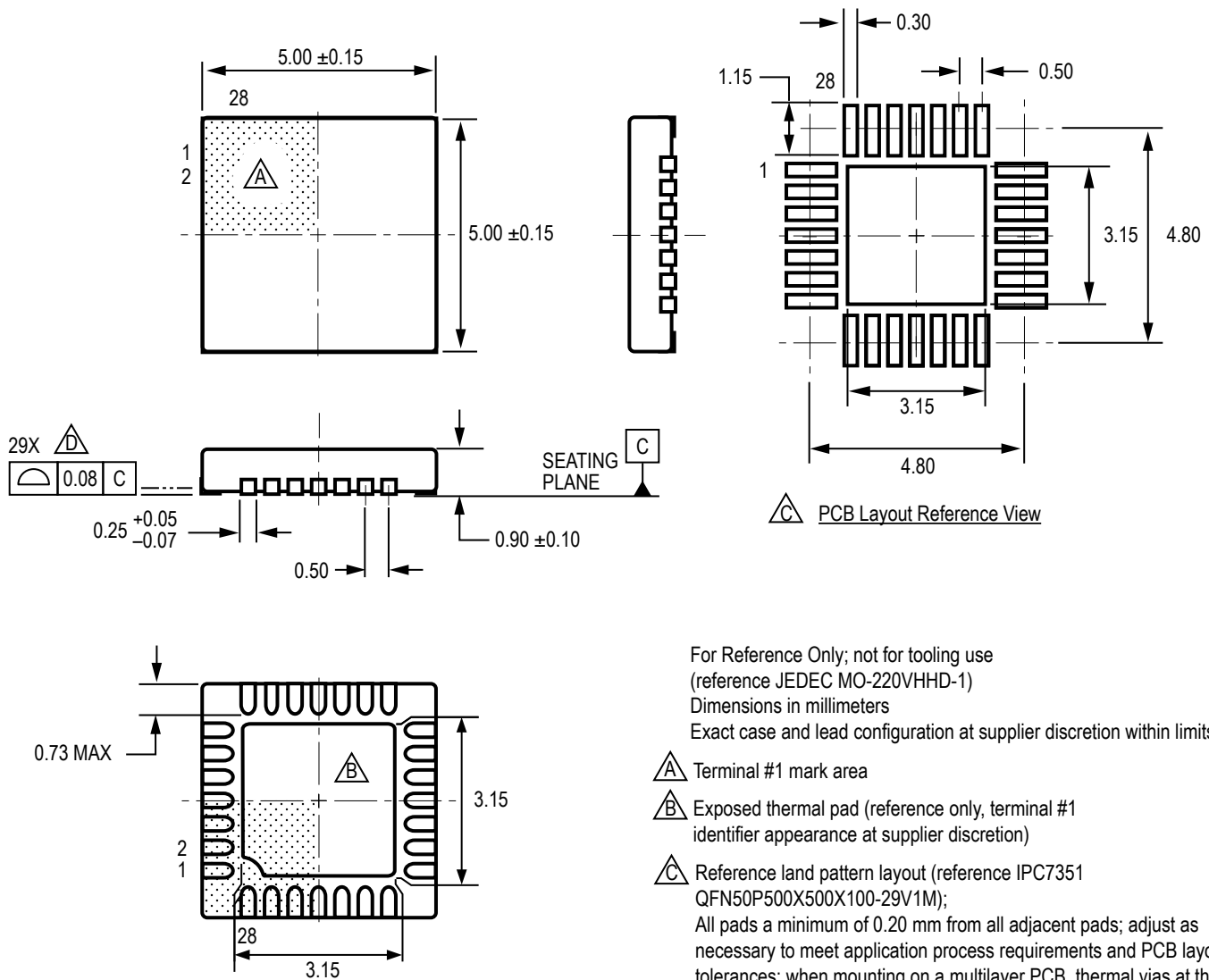

For Reference Only; not for tooling use
(reference JEDEC MO-220VHHD-1)
Dimensions in millimeters
Exact case and lead configuration at supplier discretion within limits shown

- A** Terminal #1 mark area
- B** Exposed thermal pad (reference only, terminal #1 identifier appearance at supplier discretion)
- C** Reference land pattern layout (reference IPC7351 QFN50P500X500X100-29V1M); All pads a minimum of 0.20 mm from all adjacent pads; adjust as necessary to meet application process requirements and PCB layout tolerances; when mounting on a multilayer PCB, thermal vias at the exposed thermal pad land can improve thermal dissipation (reference EIA/JEDEC Standard JESD51-5)
- D** Coplanarity includes exposed thermal pad and terminals

ET Package, 28-Pin QFN with Exposed Thermal Pad

REVISION HISTORY

| Number | Date | Description |
|--------|-----------------|--|
| – | August 14, 2015 | Initial Release |
| 1 | January 3, 2017 | Added VBB UVLO and VBB UVLO Hysteresis characteristics to page 6 |
| 2 | June 5, 2020 | Minor editorial updates |

Copyright 2020, Allegro MicroSystems.

Allegro MicroSystems reserves the right to make, from time to time, such departures from the detail specifications as may be required to permit improvements in the performance, reliability, or manufacturability of its products. Before placing an order, the user is cautioned to verify that the information being relied upon is current.

Allegro's products are not to be used in any devices or systems, including but not limited to life support devices or systems, in which a failure of Allegro's product can reasonably be expected to cause bodily harm.

The information included herein is believed to be accurate and reliable. However, Allegro MicroSystems assumes no responsibility for its use; nor for any infringement of patents or other rights of third parties which may result from its use.

Copies of this document are considered uncontrolled documents.

For the latest version of this document, visit our website:

www.allegromicro.com