

San Ace 92W

Splash proof Fan

Features

Splash proof and dust resistant

- Protection class IP55* water and dust resistant performance.
- Maintains safe operation even in harsh environments.

Large air flow and high static pressure

- Maximum air flow : 5.05 m³/min
- Maximum static pressure : 385 Pa

Energy-saving and Low noise

- Power consumption: 39.4W
- Sound Pressure Level: 64dB(A)



* "IP55" is a protection specification for protection against water sprays and dust. It is based on IEC (International Electrotechnical Commission) and JIS (Japanese Industrial Standards) and specified as follows. Ingress of dust is not entirely prevented, but it must not enter in sufficient quantity to interfere with the satisfactory operation of the equipment; complete protection against contact. Water splashing against the enclosure from any direction shall have no harmful effect.

92mm × 92mm × 38mm

Specifications

Model No.	Rated Voltage [V]	Operating Voltage Range [V]	PWM Duty Cycle [%] <small>Note 1,2)</small>	Rated Current [A]	Rated Input [W]	Rated Speed [min ⁻¹]	Air Flow		Static Pressure		SPL [dB(A)]	Operating Temperature [°C]	Life Expectancy [h]
			100				0	[m ³ /min]	[CFM]	[Pa]			
9WV0948P1H001	48	40.8 to 52.8	100	0.82	39.4	8,500	5.05	178	385	1.55	64	-10 to +70	30,000
			0	0.14	6.7	4,000	2.37	83.7	85.2	0.34	45		

Note : PWM Frequency : 25kHz

Common Specifications

- Material Frame: Plastics (Flammability: UL94V-0.) , Impeller: Plastics (Flammability: UL94V-1)
- Life Expectancy Varies for each model
(L10: Survival rate: 90% at 60°C, rated voltage, and continuously run in a free air state)
- Motor Protection System Current blocking function and reverse polarity protection
- Dielectric Strength 50/60 Hz, 500VAC, 1 minute (between lead conductor and motor case)
- Sound Pressure Level (SPL) Expressed as the value at 1m from air inlet side
- Operating Temperature Varies for each model (Non-condensing)
- Storage Temperature -30°C to +70°C (Non-Condensing)
- Lead Wire ⊕red ⊖black Sensor: yellow Control: brown
- Mass Approx. 265g

San Ace 92 W

Air Flow - Static Pressure Characteristics

PWM Duty Cycle

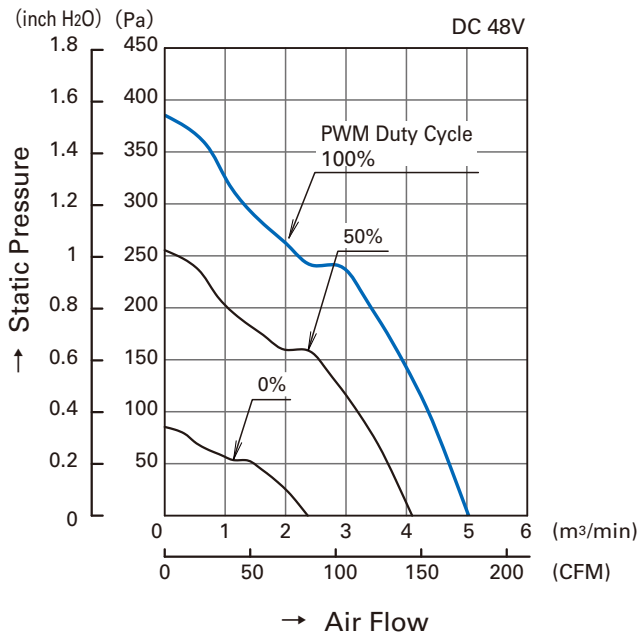

9WV0948P1H001

Operating Voltage Range

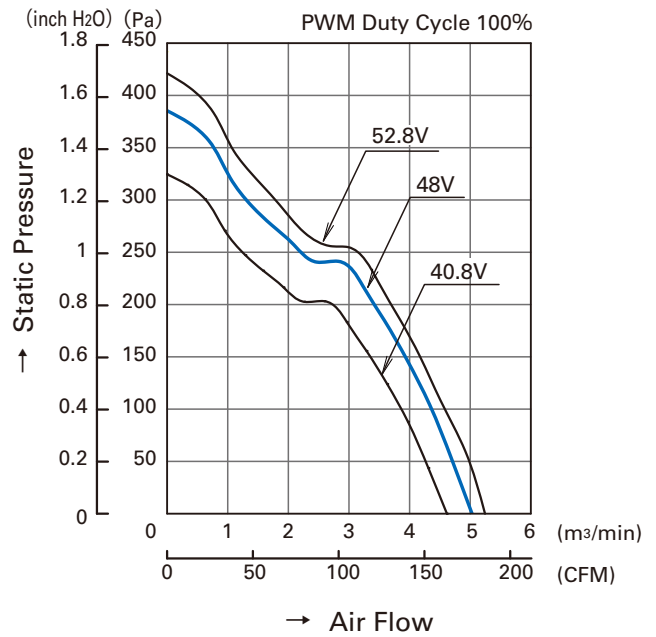

9WV0948P1H001

PWM Duty - Speed Characteristics Example

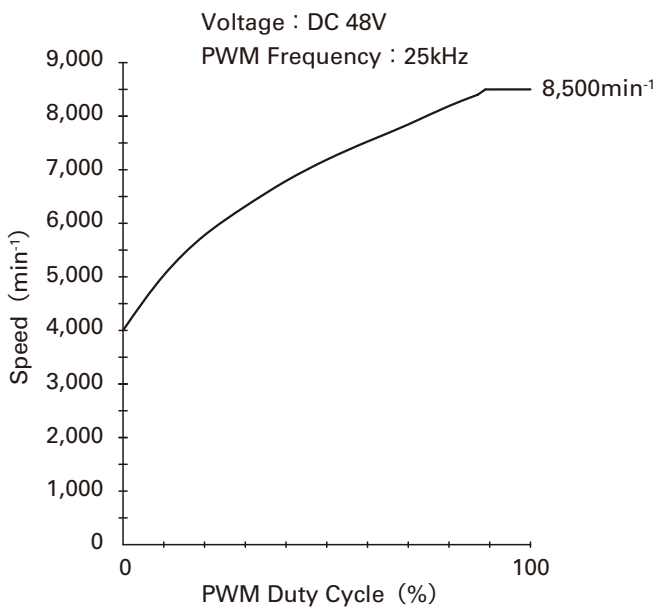

9WV0948P1H001

PWM Input Signal Example

Input Signal Wave Form

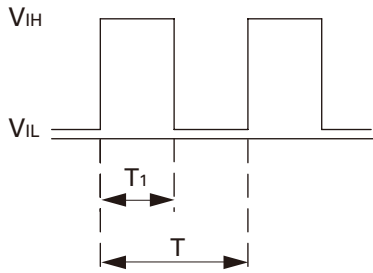

$V_{IH}=4.75V$ to $5.25V$

$V_{IL}=0V$ to $0.4V$

PWM Duty Cycle (%) = $\frac{T_1}{T} \times 100$

PWM Frequency 25 (kHz) = $\frac{1}{T}$

Source Current : 1mA Max. at control voltage 0V

Sink Current : 1mA Max. at control voltage 5.25V

Control Terminal Voltage : 5.25V Max. (Open Circuit)

When the control lead wire is no connecting, the speed is the same speed as at 100% of PWM cycle.

This fan speed should be controlled by PWM input signal of either TTL input or open collector, drain input.

Connection Schematic

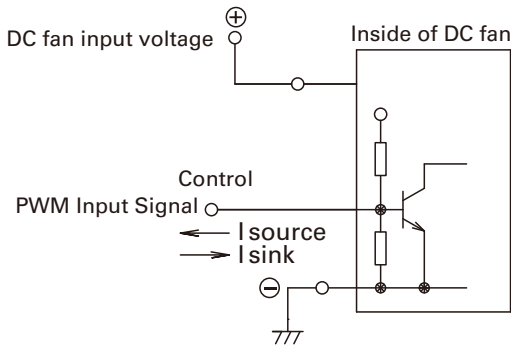

Specifications for Pulse Sensors

Output circuit : Open collector

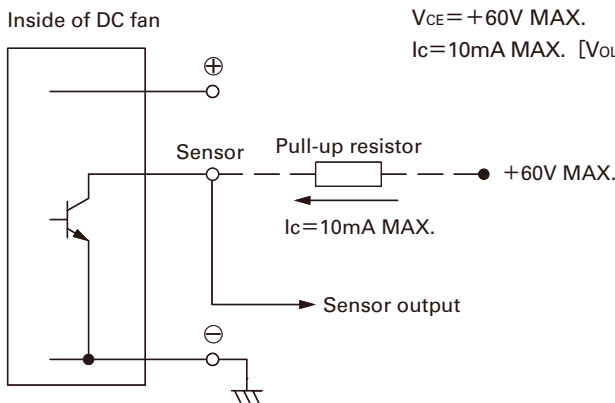

$V_{CE}=+60V$ MAX.

$I_c=10mA$ MAX. [$V_{OL}=V_{CE} (SAT) =0.4V$ MAX.]

Output waveform (Need pull-up resistor)

In case of steady running

(One revolution)

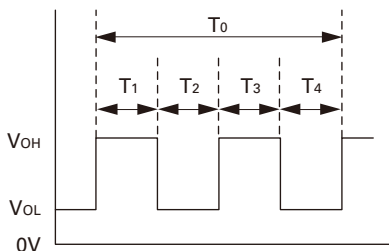

$T_{1\sim4} \doteq (1/4) T_0$

$T_{1\sim4} \doteq (1/4) T_0=60/4N$ (sec)

N =Fan speed (min^{-1})

Dimensions (unit : mm)

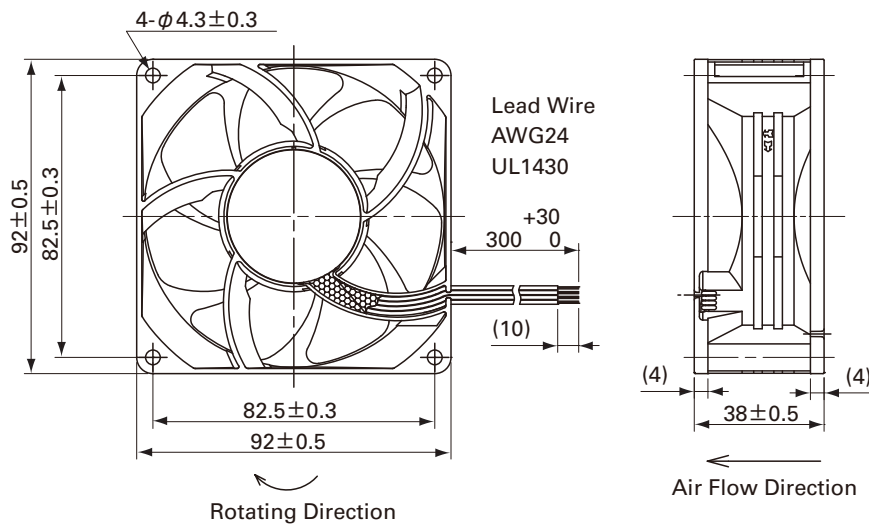

Reference dimension of mounting holes and vent opening (unit : mm)

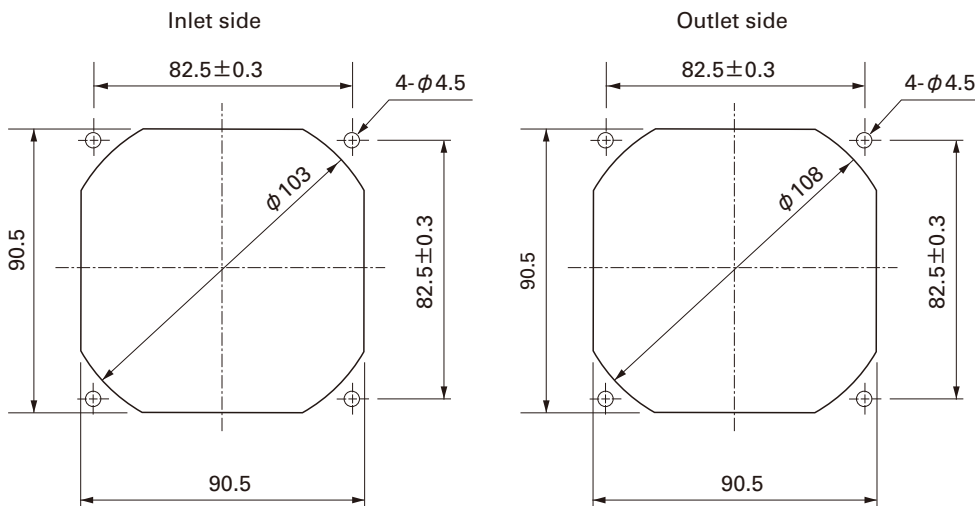

Notice

- The products shown in the catalog are subject to Japanese Export Control Law. Diversion contrary to the law of exporting country is prohibited.
- To protect against electrolytic corrosion that may occur in locations with strong electromagnetic noise, we provide fans that are unaffected by electrolytic corrosion.