



# Ø 175x69 mm

San Ace 175W 9W2T type   

## General Specifications

- Material ..... Motor case: Aluminum (Black coating), Impeller: Plastic (Flammability: UL 94V-0)
- Expected life ..... See the table below. (L10 life: 90% survival rate for continuous operation in indoor free air at 60°C, rated voltage)
- Motor protection function ..... Locked rotor burnout protection, Reverse polarity protection  
For details, please refer to p. 547.
- Dielectric strength ..... 50/60 Hz, 500 VAC, for 1 minute (between lead wire conductors and motor case)
- Insulation resistance ..... 10 MΩ or more with a 500 VDC megger (between lead wire conductors and motor case)
- Sound pressure level (SPL) ..... At 1 m away from the air inlet
- Storage temperature ..... -30 to +70°C (Non-condensing)
- Lead wire ..... ⊕Red ⊖Black (Sensor) Yellow (Control) Brown
- Mass ..... 980 g
- Ingress protection ..... IP56

## Specifications When the optional inlet nozzle (109-1073H) is mounted.

The models listed below **have pulse sensors with PWM control function.**

Model no.	Rated voltage [V]	Operating voltage range [V]	PWM duty cycle* [%]	Rated current [A]	Rated input [W]	Rated speed [min <sup>-1</sup> ]	Max. airflow [m <sup>3</sup> /min] [CFM]	Max. static pressure [Pa] [inchH <sub>2</sub> O]	SPL [dB (A)]	Operating temperature [°C]	Expected life [h]
9W2TGA48P0G001	48	36 to 72	100	3.85	184.8	5700	17.3 611	1100 4.42	80	-30 to +60	40000/60°C (70000/40°C)
			15	0.08	3.84	800	2.4 84.7	21.7 0.087	38		

\* PWM frequency: 25 kHz. Fan does not rotate when PWM duty cycle is 0%.  
Max input is 330 W at rated voltage.

## Airflow - Static Pressure Characteristics / PWM Duty - Speed Characteristics Example

**9W2TGA48P0G001** With pulse sensor with PWM control function

PWM duty cycle

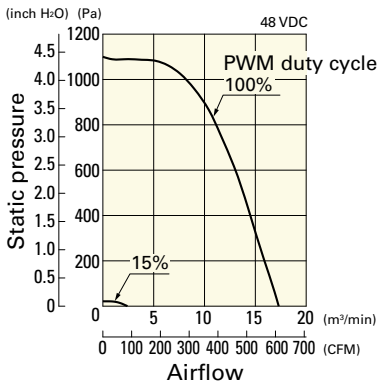

Operating voltage range

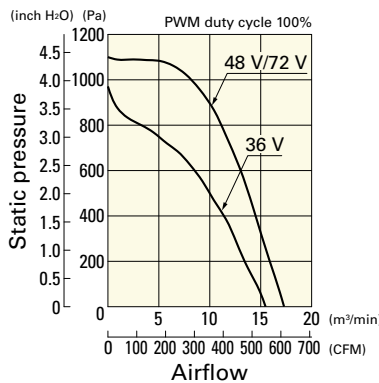

PWM duty - Speed characteristics example

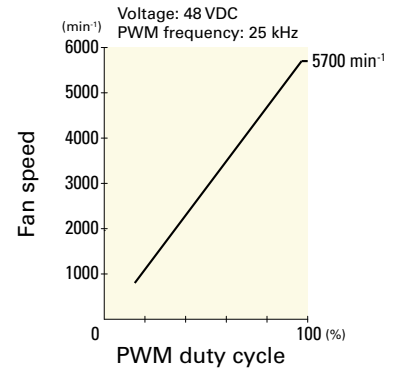

**Dimensions (unit: mm)**

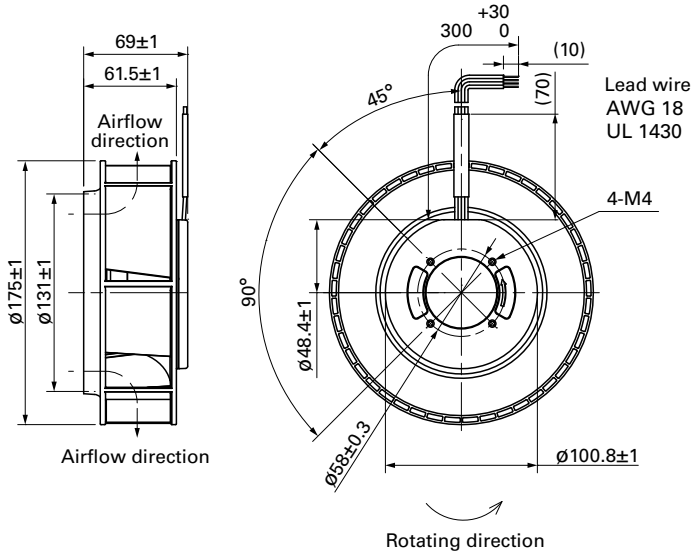

**Reference Dimensions of Mounting Holes and Vent Opening (unit: mm)**

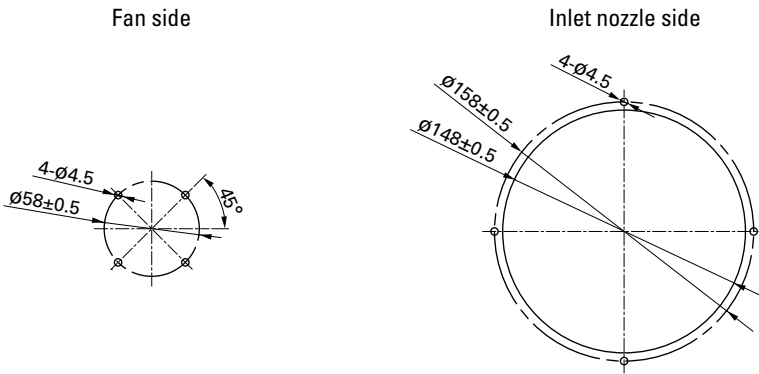

**Reference Diagram for Mounting**

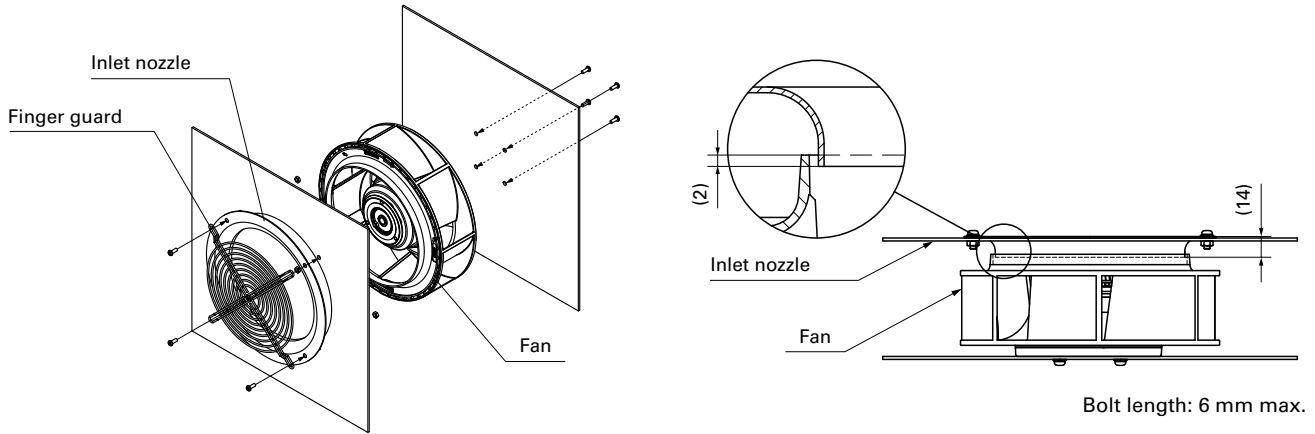

**Options**

Finger guards

page: p. 533

Model no.: 109-722, 109-722H

Inlet nozzle

page: p. 537

Model no.: 109-1073, 109-1073H