

# San Ace 97W 9W1B type

## Splash Proof Blower

### Features

#### High Static Pressure and High Airflow

This blower delivers a maximum static pressure of 540 Pa and a maximum airflow of 1.09 m<sup>3</sup>/min.\*

Blowers can send out straight airflow with high static pressure, making them suitable for localized and spot cooling applications.

#### Water and Dust Resistance

Its IP68-rated\*\* water and dust protection ensures stable fan operation even in harsh environments.

#### High Energy Efficiency and Low Noise

The PWM control function enables the control of fan speed, contributing to lowering noise and improving energy efficiency of devices.

\*These values are for models 9W1BM12P2H001 and 9W1BM24P2H001

\*\*The degree of protection (IP code) is defined by IEC 60529 (International Electrotechnical Commission).

IP68:

- Completely protected against dust
- Protected against submersion in water



**97 x 33 mm**

### Specifications

The models listed below **have pulse sensors with PWM control function.**

Model no.	Rated voltage [V]	Operating voltage range [V]	PWM duty cycle* [%]	Rated current [A]	Rated input [W]	Rated speed [min <sup>-1</sup> ]	Max. airflow [m <sup>3</sup> /min] [CFM]	Max. static pressure [Pa] [inchH <sub>2</sub> O]	SPL [dB(A)]	Operating temperature [°C]	Expected life [h]
9W1BM12P2H001	12	10.2 to 13.8	100	1.30	15.6	4800	1.09 38.5	540 2.17	58	-20 to +70	40000/60°C (70000/40°C)
			20	0.14	1.68	1500	0.32 11.3	51 0.20	30		
9W1BM12P2M001			100	0.90	10.8	4100	0.93 32.8	380 1.53	55		
			20	0.14	1.68	1500	0.32 11.3	51 0.20	30		
9W1BM24P2H001	24	20.4 to 27.6	100	0.65	15.6	4800	1.09 38.5	540 2.17	58		
			20	0.07	1.68	1500	0.32 11.3	51 0.20	30		
9W1BM24P2M001			100	0.45	10.8	4100	0.93 32.8	380 1.53	55		
			20	0.07	1.68	1500	0.32 11.3	51 0.20	30		

\* PWM frequency: 25 kHz. Fan does not rotate when PWM duty cycle is 0%.

Models with the following sensor specifications are also available as options: Without sensor Lock sensor

### Common Specifications

- Material ..... Frame: Aluminum (Black coating), Plastic (Flammability: UL 94V-0)  
Impeller: Plastic (Flammability: UL 94V-0)
- Expected life ..... Refer to specifications  
(L10 life: 90% survival rate for continuous operation in indoor free air at 60°C, rated voltage)  
Expected life at 40°C is for reference only.
- Motor protection system ..... Current blocking function and reverse polarity protection
- Dielectric strength ..... 50/60 Hz, 500 VAC, for 1 minute (between lead wire conductors and frame)
- Sound pressure level (SPL) ..... At 1 m away from the air inlet
- Operating temperature ..... Refer to specifications (Non-condensing)
- Storage temperature ..... -30 to +70°C (Non-condensing)
- Lead wire ..... ⊕ Red ⊖ Black Sensor Yellow Control Brown
- Mass ..... 240 g
- Ingress protection ..... IP68

## Airflow - Static Pressure Characteristics

• PWM duty cycle

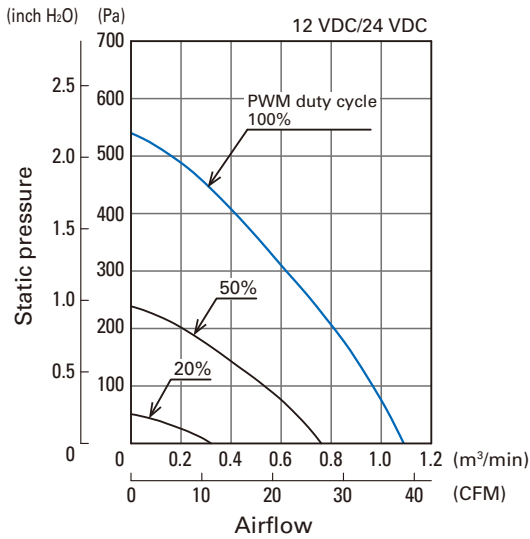

**9W1BM12P2H001**  
**9W1BM24P2H001**

• Operating voltage range

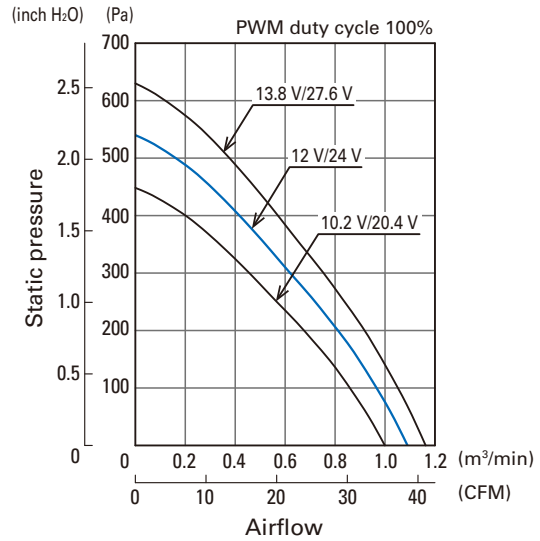

**9W1BM12P2H001**  
**9W1BM24P2H001**

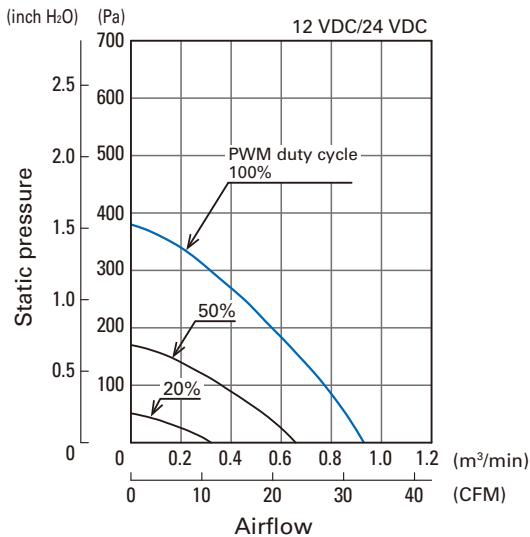

**9W1BM12P2M001**  
**9W1BM24P2M001**

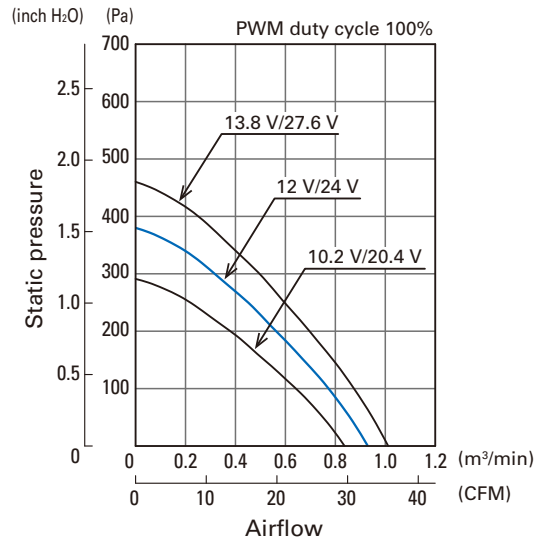

**9W1BM12P2M001**  
**9W1BM24P2M001**

## PWM Duty - Speed Characteristics Example

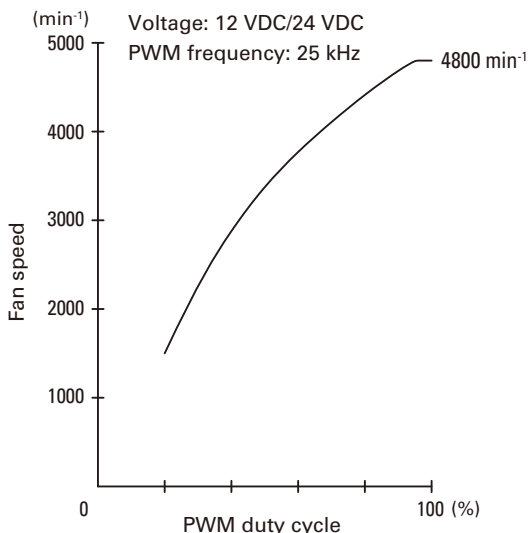

**9W1BM12P2H001**  
**9W1BM24P2H001**

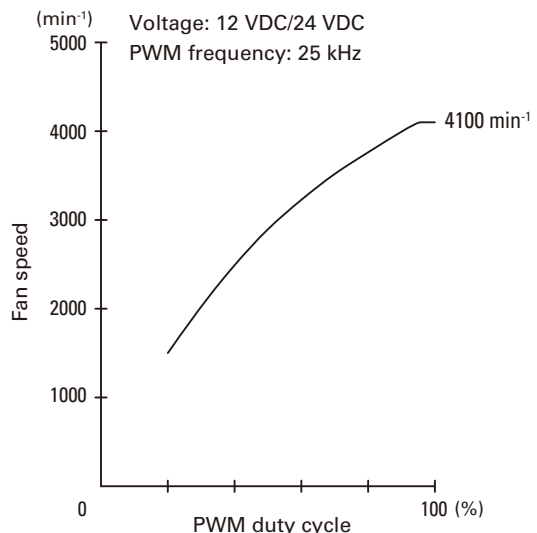

**9W1BM12P2M001**  
**9W1BM24P2M001**

### PWM Input Signal Example

Input signal waveform

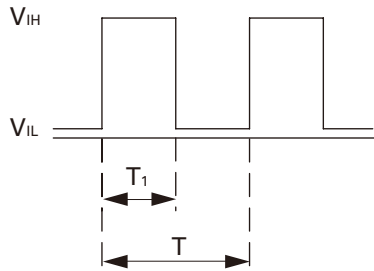

$V_{IH} = 4.75 \text{ to } 5.25 \text{ V}$     $V_{IL} = 0 \text{ to } 0.4 \text{ V}$   
 $\text{PWM duty cycle (\%)} = \frac{T_1}{T} \times 100$     $\text{PWM frequency } 25 \text{ (kHz)} = \frac{1}{T}$   
 $\text{Current source (I}_{\text{source}}) = 1 \text{ mA max. (when control voltage is } 0 \text{ V)}$   
 $\text{Current sink (I}_{\text{sink}}) = 1 \text{ mA max. (when control voltage is } 5.25 \text{ V)}$   
 $\text{Control terminal voltage} = 5.25 \text{ V max. (when control terminal is open)}$

When the control terminal is open,  
 fan speed is the same as when PWM duty cycle is 100%.  
 Either TTL input, open collector or open drain can be used for  
 PWM control input signal.

### Example of Connection Schematic

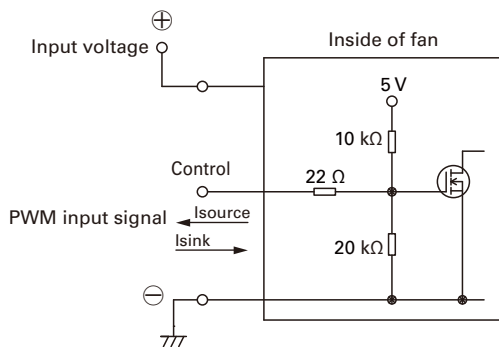

### Specifications for Pulse Sensors

Output circuit: Open collector



$V_{CE} = +27.6 \text{ V max.}$   
 $I_c = 5 \text{ mA max. [V}_{OL} = V_{CE} \text{ (SAT)} = 1.0 \text{ V max.}]$

Output waveform (Need pull-up resistor)

In case of steady running

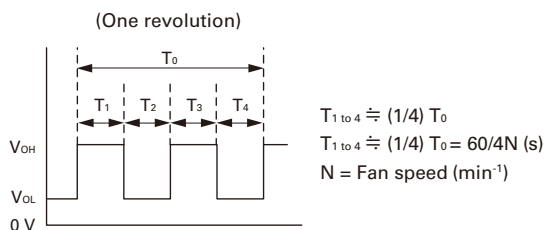

**Dimensions (unit: mm)**

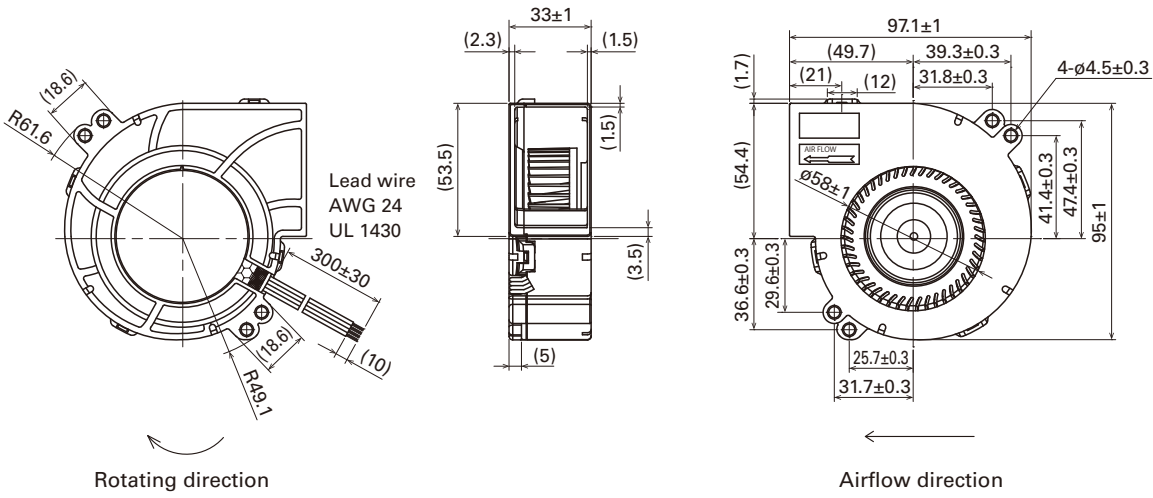

**Notice**

- Please read the "Safety Precautions" on our website before using the product.
- The products shown in this catalog are subject to Japanese Export Control Law. Diversion contrary to the law of exporting country is prohibited.
- For protecting fan bearings against electrolytic corrosion near strong electromagnetic noise sources, we provide effective countermeasures such as Electrolytic Corrosion Proof Fans and EMC guards. Contact us for details.

**SANYO DENKI CO., LTD.** 3-33-1 Minami-Otsuka, Toshima-ku, Tokyo 170-8451, Japan TEL: +81 3 5927 1020

<https://www.sanyodenki.com>

The names of companies and/or their products specified in this catalog are the trade names, and/or trademarks and/or registered trademarks of such respective companies.

"San Ace" is a trademark of SANYO DENKI CO.,LTD.

Specifications are subject to change without notice.

CATALOG No. C1092B002 '19.5