

San Ace C175

Centrifugal Fan

Centrifugal Fan 175mm

Features

Large air flow and high static pressure

- Maximum air flow : 14.0 m³/min
- Maximum static pressure : 885 Pa

Energy-saving design

- Power consumption: 93.6 W

Low noise

- Sound Pressure Level: 73dB(A)



φ175mm×69mm

Specifications Note 3)

Model No.	Rated Voltage [V]	Operating Voltage Range [V]	PWM Duty Cycle [%] <small>Note 1,2)</small>	Rated Current [A]	Rated Input [W]	Rated Speed [min ⁻¹]	Air Flow		Static Pressure		SPL [dB(A)]	Operating Temperature [°C]	Life Expectancy [h]
							[m ³ /min]	[CFM]	[Pa]	[inchH ₂ O]			
9TG24P0G01	24	20.4 to 27.6	100	3.9	93.6	4,700	14.0	494.7	885	3.55	73	-10 to +60	40,000
9TG48P0G01	48	36 to 55.2	100	1.95	93.6	4,700	14.0	494.7	885	3.55	73	-10 to +70	

Note 1 : PWM Frequency : 25kHz

Note 2 : Fan does not rotate when PWB duty cycle is 0%.

Note 3 : When inlet nozzle [Option (Model : 109-1073)] is mounted.

Note 4 : Max input is 130 W at rated voltage.

Common Specifications

- Material Motor case: Aluminum, Impeller: Plastics (Flammability: UL94V-1Min.)
- Life Expectancy Varies for each model
(L10: Survival rate: 90% at 60°C, rated voltage, and continuously run in a free air state)
- Motor Protection System Current blocking function and reverse polarity protection
- Dielectric Strength 50/60 Hz, 500VAC, 1 minute (between lead conductor and motor case)
- Sound Pressure Level (SPL) Expressed as the value at 1m from air inlet side
- Operating Temperature Varies for each model (Non-condensing)
- Storage Temperature -30°C to +70°C (Non-Condensing)
- Lead Wire ⊕red ⊖black Sensor: yellow Control: brown
- Mass Approx. 750g

175mm

SanAce C175

Air Flow - Static Pressure Characteristics

- PWM Duty Cycle

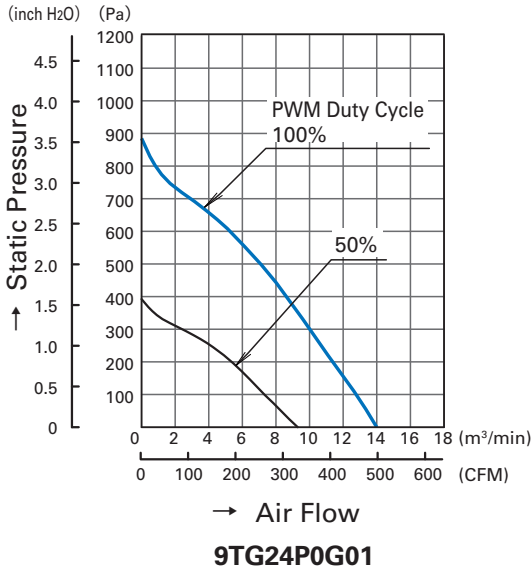

- Operating Voltage Range

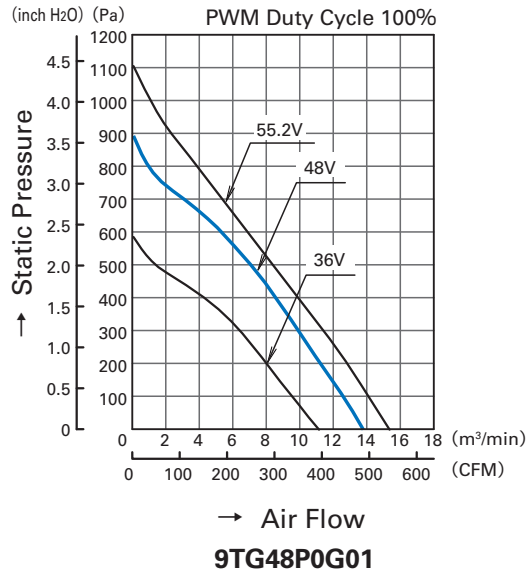
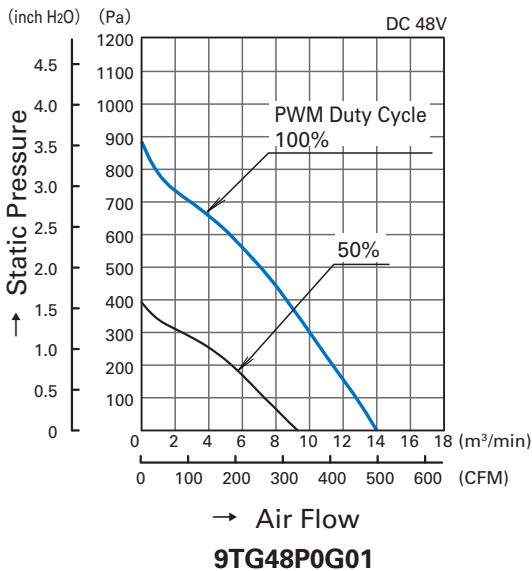
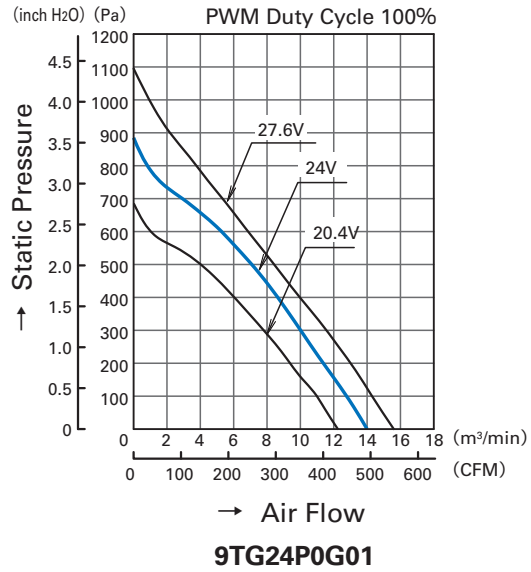

PWM Duty - Speed Characteristics Example

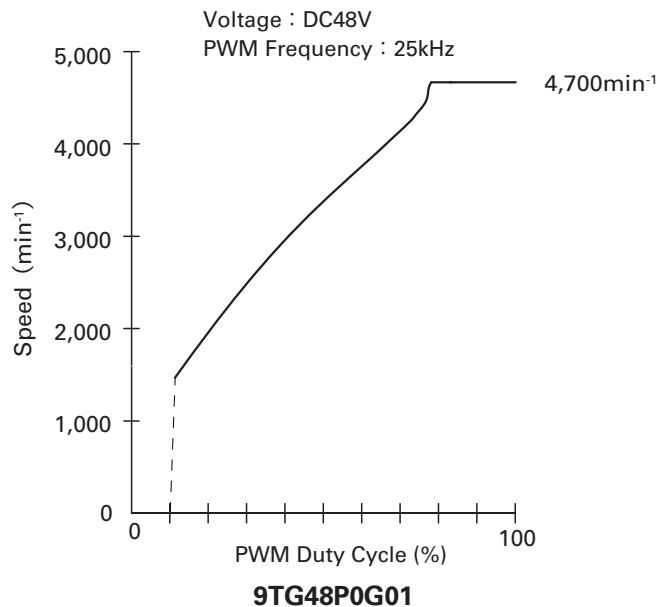
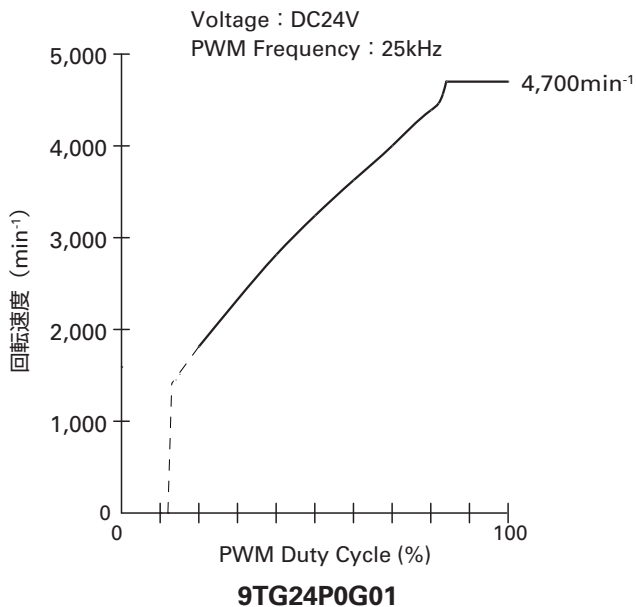

PWM Input Signal Example

Input Signal Wave Form

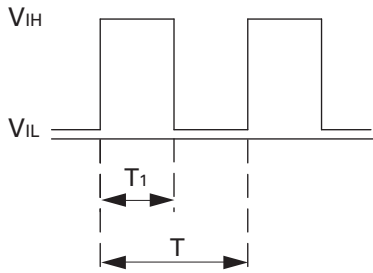

$V_{IH}=4.75V$ to $5.25V$

$V_{IL}=0V$ to $0.4V$

PWM Duty Cycle (%) = $\frac{T_1}{T} \times 100$

PWM Frequency 25 (kHz) = $\frac{1}{T}$

Source Current : 2mA Max. at control voltage 0V

Sink Current : 1mA Max. at control voltage 5.25V

Control Terminal Voltage : 5.25V Max. (Open Circuit)

When the control lead wire is no connecting, the speed is the same speed as at 100% of PWM cycle.

This fan speed should be controlled by PWM input signal of either TTL input or open collector, drain input.

Connection Schematic

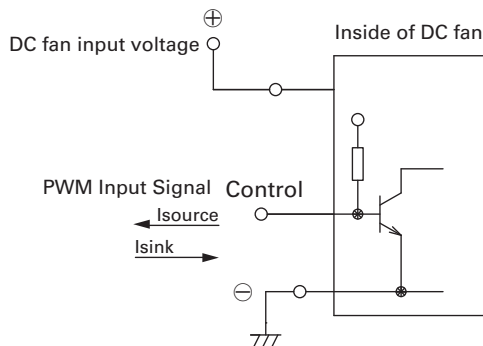

Specifications for Pulse Sensors

Output circuit : Open collector

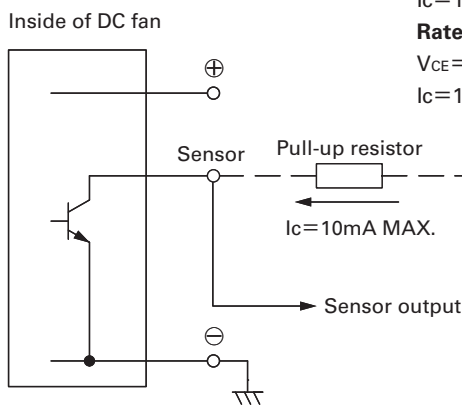

Rated Voltage 24V fan

$V_{CE}=+30V$ MAX.

$I_c=10mA$ MAX. [$V_{OL}=V_{CE} (SAT) =0.6V$ MAX.]

Rated Voltage 48V fan

$V_{CE}=+60V$ MAX.

$I_c=10mA$ MAX. [$V_{OL}=V_{CE} (SAT) =0.4V$ MAX.]

Output waveform (Need pull-up resistor)

In case of steady running

(One revolution)

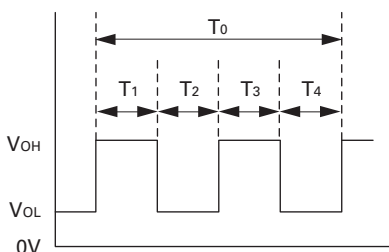

$T_{1\sim4} \doteq (1/4) T_0$

$T_{1\sim4} \doteq (1/4) T_0 = 60/4N$ (sec)

$N = \text{Fan speed (min}^{-1}\text{)}$

Dimensions (unit : mm)

Fan

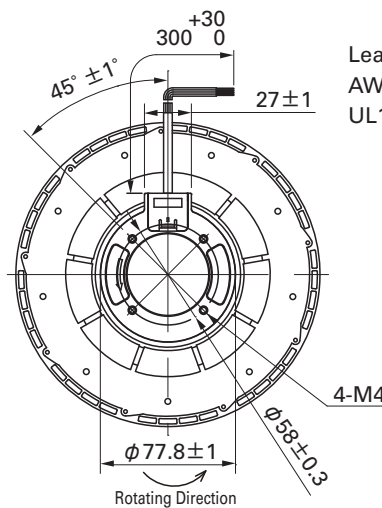
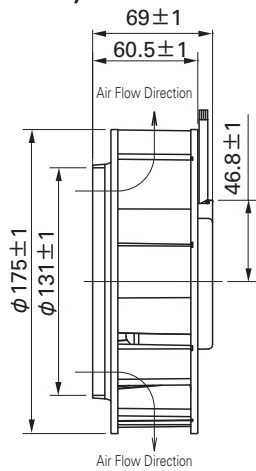

Lead Wire
AWG24
UL1430

Inlet nozzle
(Model : 109-1073)

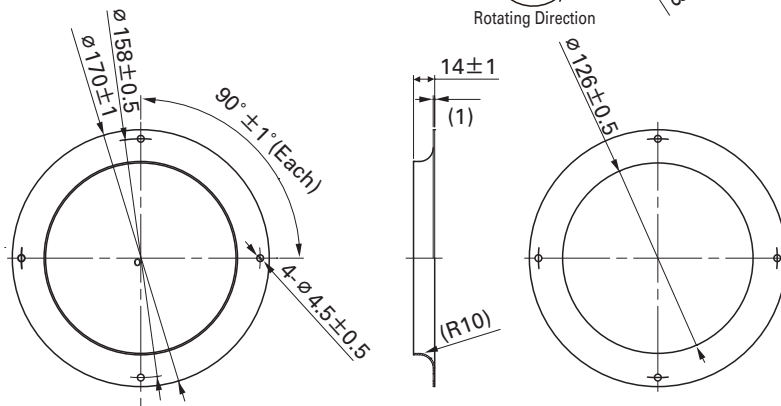

Inlet nozzle: Nozzle mounted in fan inlet side to adjust the flow of introduced air

Reference dimension of mounting holes and vent opening (unit : mm)

Fan side

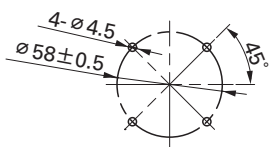

Inlet nozzle side

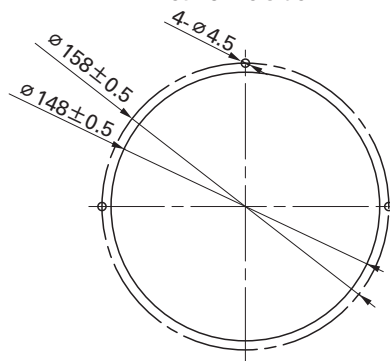

Reference diagram for mounting

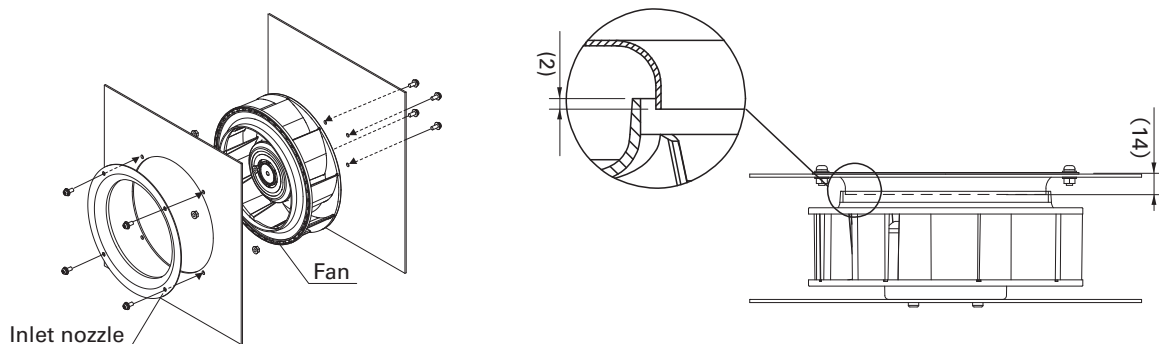

Screw length should be 4 mm or more but not exceeding 6 mm from fan edge face.
To prevent screw from loosening, use plain washer and spring washer.

Notice

- The products shown in the catalog are subject to Japanese Export Control Law. Diversion contrary to the law of exporting country is prohibited.
- To protect against electrolytic corrosion that may occur in locations with strong electromagnetic noise, we provide fans that are unaffected by electrolytic corrosion.