

San Ace 60 GA type

Low Power Consumption Fan

Features

Energy-saving

Power consumption is reduced by approx. 38 % compared with our conventional fan*.

Low noise

Sound pressure level is reduced by 5 dB(A) compared with our conventional fan*.

* Our conventional product is the DC cooling fan :
60 × 60 × 15 mm thick fan "San Ace 60" (109P0612K701)



60mm × 60mm × 15mm

Specifications

Model No.	Rated Voltage [V]	Operating Voltage Range [V]	PWM Duty Cycle [%] <small>Note1</small>	Rated Current [A]	Rated Input [W]	Rated Speed [min ⁻¹]	Air Flow [m ³ /min] [CFM]		Static Pressure [Pa] [inchH ₂ O]		SPL [dB(A)]	Operating Temperature [°C]	Life Expectancy [h]
9GA0612P7G01	12	10.2 to 13.8	100	0.16	1.92	5,900	0.68	24	80	0.320	38	-10 to +70	40,000
			0	0.05	0.60	1,500	0.17	6.0	5.2	0.020	10		
9GA0612P7H01			100	0.10	1.2	4,900	0.56	19.7	55.6	0.223	34		
			0	0.03	0.36	1,300	0.15	5.3	3.9	0.015	8		

Note : PWM Frequency : 25kHz

Common Specifications

- Material Frame, Impeller : Plastics (Flammability: UL94V-0)
- Life Expectancy Varies for each model
(L10: Survival rate: 90% at 60°C, rated voltage, and continuously run in a free air state)
- Motor Protection System Current blocking function and Reverse polarity protection
- Dielectric Strength 50/60 Hz, 500VAC, 1 minute (between lead conductor and frame)
- Sound Pressure Level (SPL) Expressed as the value at 1m from air inlet side
- Operating Temperature Varies for each model (Non-condensing)
- Storage Temperature -30°C to +70°C (Non-Condensing)
- Lead Wire ⊕red ⊖black Sensor: yellow Control: brown
- Mass Approx. 50g

SanAce 60 GAtype

Air Flow and Static Pressure Characteristics

PWM Duty Cycle

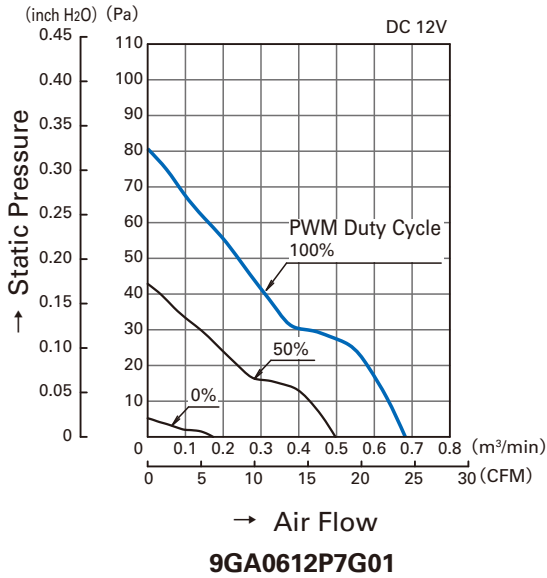

Operating Voltage Range

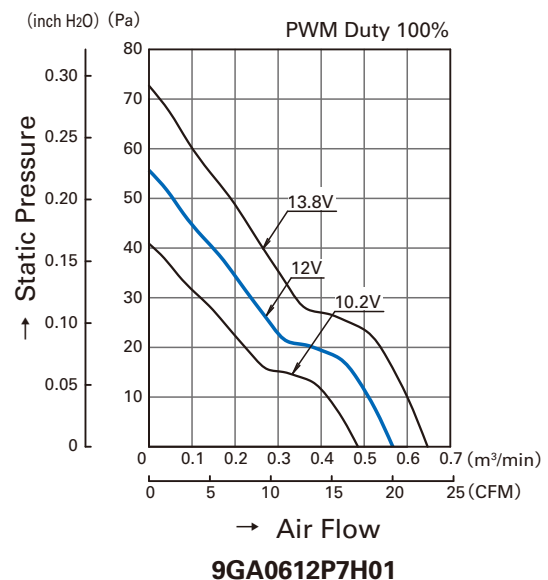
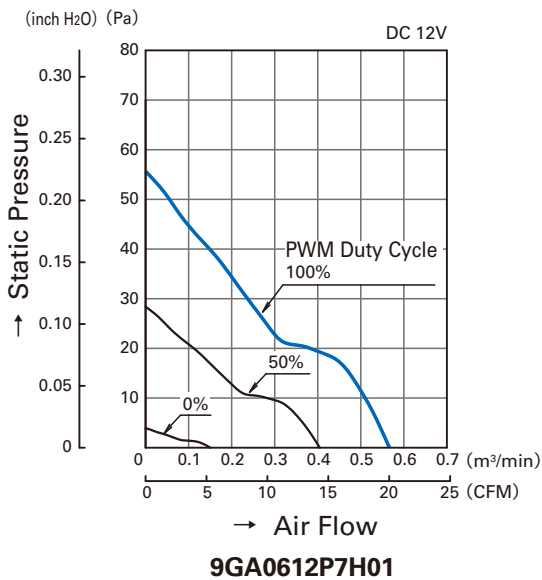
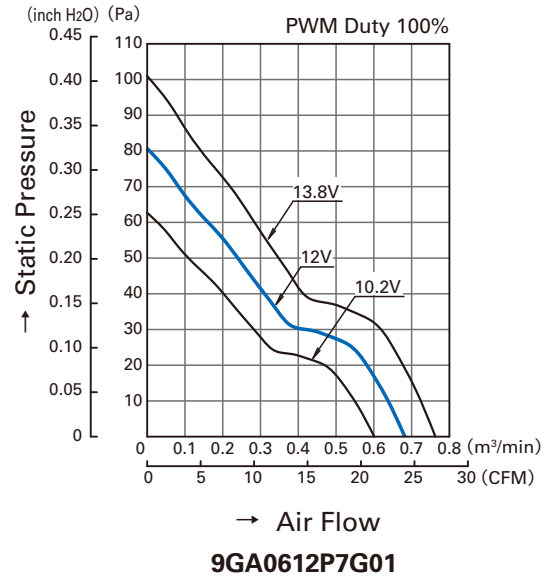

PWM Duty - Speed Characteristics Example

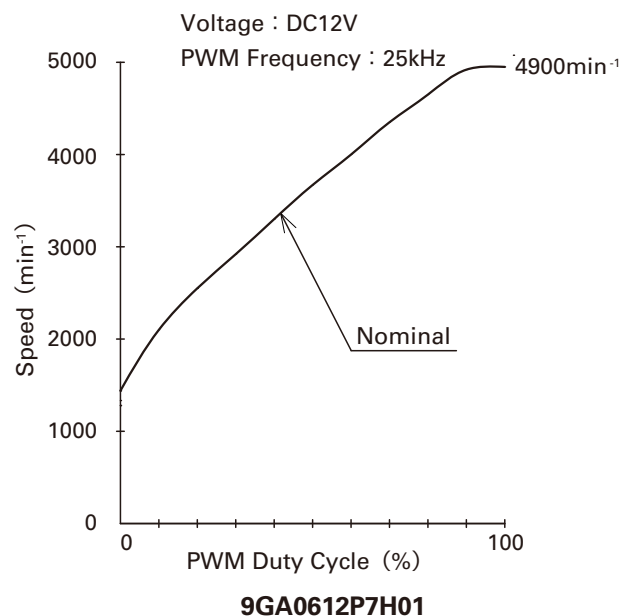
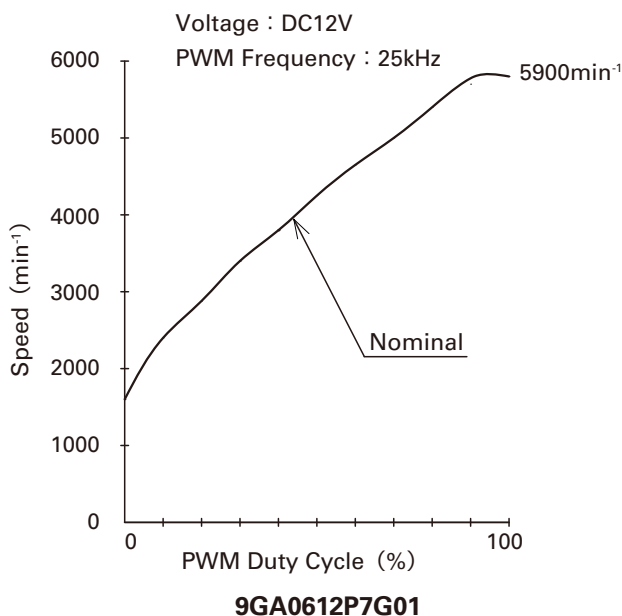

PWM Input Signal Example

Input Signal Wave Form

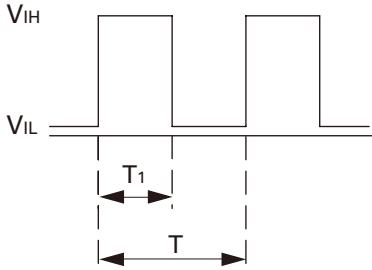

$V_{IH}=4.75V$ to $5.25V$

$V_{IL}=0V$ to $0.4V$

PWM Duty Cycle (%) = $\frac{T_1}{T} \times 100$

PWM Frequency 25 (kHz) = $\frac{1}{T}$

Source Current : 1mA Max. at control voltage 0V

Sink Current : 1mA Max. at control voltage 5.25V

Control Terminal Voltage : 5.25V Max. (Open Circuit)

When the control lead wire is no connecting, the speed is the same speed as at 100% of PWM cycle.

This fan speed should be controlled by PWM input signal of either TTL input or open collector, drain input.

Connection Schematic

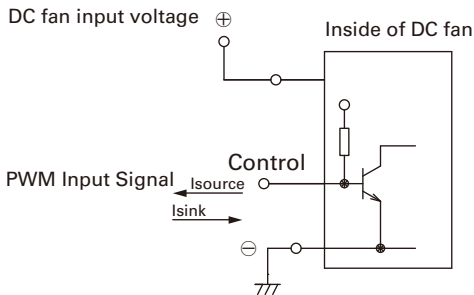

Specifications for Pulse Sensors

Output circuit : Open collector

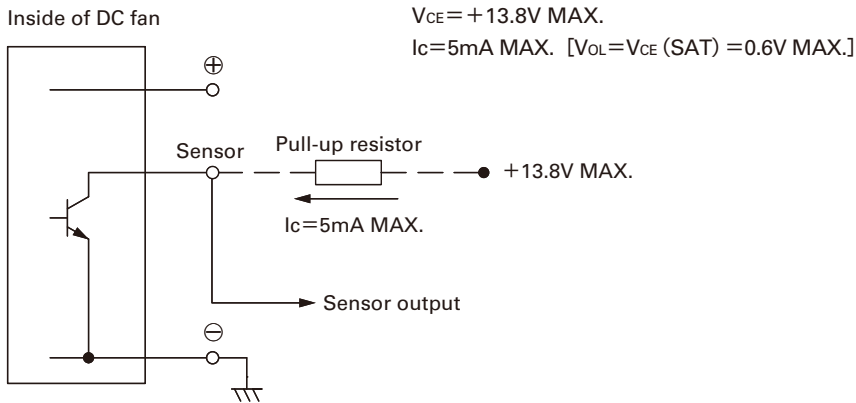

$V_{CE}=+13.8V$ MAX.

$I_c=5mA$ MAX. [$V_{OL}=V_{CE} (SAT) =0.6V$ MAX.]

Output waveform (Need pull-up resistor)

In case of steady running

(One revolution)

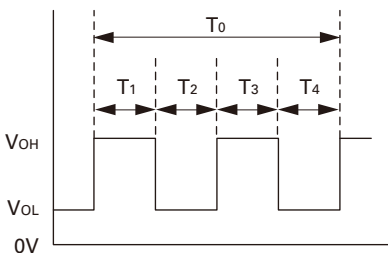

$T_{1\sim 4} \doteq (1/4) T_0$

$T_{1\sim 4} \doteq (1/4) T_0=60/4N$ (sec)

N =Fan speed (min^{-1})

■ Dimensions (unit : mm)

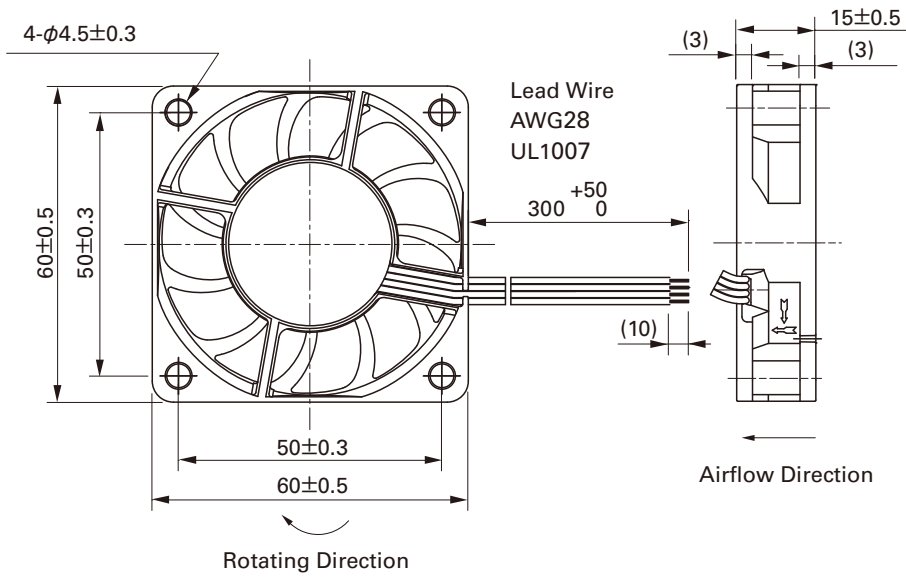

■ Reference dimension of mounting holes and vent opening (unit : mm)

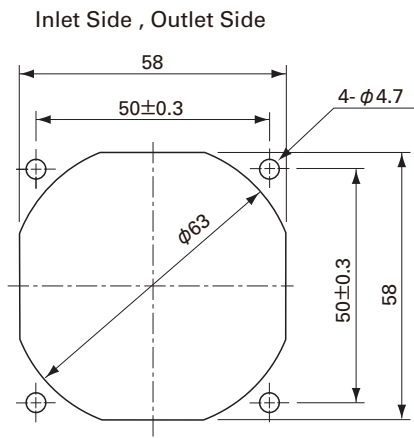

Notice

- The products shown in the catalog are subject to Japanese Export Control Law. Diversion contrary to the law of exporting country is prohibited.
- To protect against electrolytic corrosion that may occur in locations with strong electromagnetic noise, we provide fans that are unaffected by electrolytic corrosion.