

Product description	M12-A male angled panel mount connector, Contacts: 4, unshielded, dip-solder, IP68, UL, for PCB assembly, two-part design
Area	M12-A series 763
Order number	99 3431 202 04

Assembly instructions / Panel cut-out

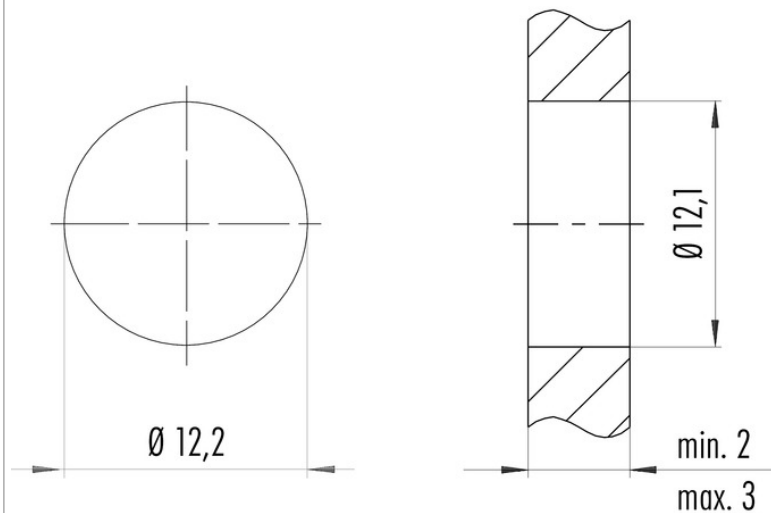

Anzugsdrehmoment/Tightening torque
M12 x 1 1,00 Nm

Product description	M12-A male angled panel mount connector, Contacts: 4, unshielded, dip-solder, IP68, UL, for PCB assembly, two-part design
Area	M12-A series 763
Order number	99 3431 202 04

Security notices

The connector must not be plugged or unplugged under load. Non-observance and improper use can result in personal injury.

The connectors have been developed for applications in plant engineering, control and electrical equipment construction. The user is responsible for checking whether the connectors can also be used in other areas of application.

Plug connectors with enclosure protection IP 67 and IP 68 are not suitable for use under water. When used outdoors, the plug connectors must be protected separately against corrosion. For further information on the IP protection classes, please refer to the "Technical Information" download centre.