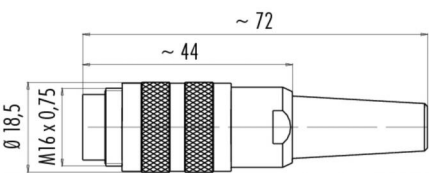
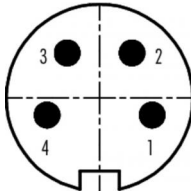

Product description	M16 IP40 cable connector, Contacts: 4, 6.0 - 8.0 mm, shieldable, solder, IP40
Area	M16 IP40 series 581
Order number	99 2009 02 04

Illustration	Scale drawing	Contact arrangement															
		 <table border="1" style="margin-left: 20px;"> <thead> <tr> <th></th> <th>X</th> <th>Y</th> </tr> </thead> <tbody> <tr> <td>1</td> <td>3,32</td> <td>-1,08</td> </tr> <tr> <td>2</td> <td>2,05</td> <td>2,83</td> </tr> <tr> <td>3</td> <td>-2,05</td> <td>2,83</td> </tr> <tr> <td>4</td> <td>-3,32</td> <td>-1,08</td> </tr> </tbody> </table>		X	Y	1	3,32	-1,08	2	2,05	2,83	3	-2,05	2,83	4	-3,32	-1,08
	X	Y															
1	3,32	-1,08															
2	2,05	2,83															
3	-2,05	2,83															
4	-3,32	-1,08															

You can find the component part drawing on the next page.

Technical data

General values

Connector design	cable connector
Connector locking system	screw
Termination	solder
Wire gauge (mm)	0.75 mm ²
Wire gauge (AWG)	18
Cable outlet	6.0 - 8.0 mm
Upper limit temperature	85 °C
Lower limit temperature	- 40 °C
Customs tariff number	85369010
Packaging Unit	40

Electrical values

Rated current (40 °C)	6 A
Rated voltage	250 V
Rated impulse voltage	1500 V
Pollution degree	1
Overvoltage category	I
Insulating material group	III
Insulation resistance	≥ 10 ¹⁰ Ω
EMC compliance	shieldable
Degree of protection	IP40
Mechanical operation	> 500 Mating cycles

Material

Contact material	CuZn (brass)
Contact plating	Ag (silver)
Contact body material	PBT (UL94 V-0)

Product description **M16 IP40 cable connector, Contacts: 4, 6.0 - 8.0 mm, shieldable, solder, IP40**

Area **M16 IP40 series 581**
Order number **99 2009 02 04**

Component part drawing

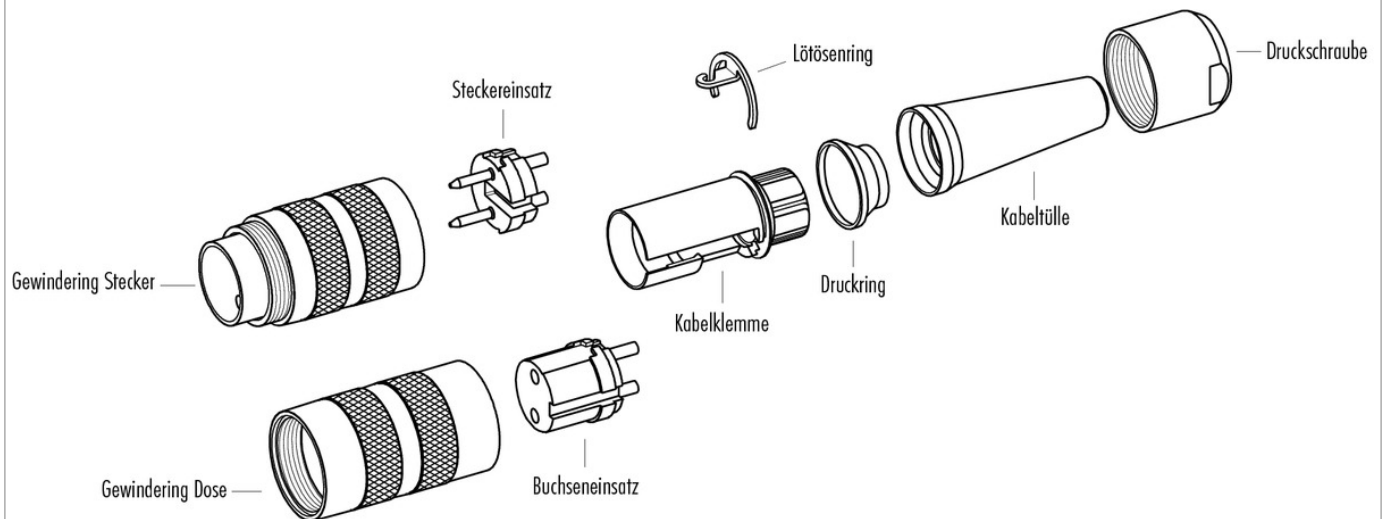

Product description **M16 IP40 cable connector, Contacts: 4, 6.0 - 8.0 mm, shieldable, solder, IP40**

Area **M16 IP40 series 581**
Order number **99 2009 02 04**

Security notices

The connector must not be connected or separated under load. Non-observance and incorrect use can result in personal injury.

The connectors are designed for use in plant, control system and electrical equipment. The end user is responsible for checking whether the connectors are suitable for use in other applications.

To prevent the connector being opened unintentionally when used in electrical circuits containing hazardous life parts, the thread between the housing and the connector head must be secured using a suitable cyanoacrylate adhesive. This does not apply to connectors used in SELV and PELV circuits according to IEC 61140 (EN 61140, VDE 0140-1).

Connectors used in electrical circuits containing hazardous life parts must only be assembled and used by or under the supervision of persons with the requisite electrotechnical training, taking the applicable regulations and standards into account.

The connector is not suitable for mains voltages. Please observe the pollution degrees and the overvoltage category. For further information refer to 'Technical support' in the Download Centre.

To lock the cable connector to the equipment connector, the threaded ring is tightened until it is 'finger-tight' (approx. 50 cNm).