

PRODUCT NUMBER
98401-XXX-XXLF

WHEN REQUIRED, ADD SUFFIX LETTER "LF"
INDICATES THE PRODUCT IS RoHS
COMPATIBLE, SEE NOTE 7

TOTAL NB OF POSITIONS, 8 TO 50

PACKAGING TYPE, NOTE 3

PLATING

1=0.76µm GOLD/GXT ON CONTACT AREA
3.81µm TIN-LEAD ON TAIL

4=3.81µm TIN-LEAD ON CONTACT AREA
AND ON TAIL

8=0.38µm GOLD/GXT ON CONTACT AREA
3.81µm TIN-LEAD ON TAIL

PIN STYLE	MATING	OAH
01	5.84	10.2
02	8.08	12.4
03	13.00	17.4
06	10.50	14.85
07	14.50	18.90

WHEN "LF" IS REQUIRED, 2µm MIN
MATTE TIN OVER 1.27µm MIN NICKEL
INSTEAD OF TIN-LEAD

NOTES:

- HOUSING MAT'L : HIGH TEMPERATURE THERMOPLASTIC. UL94V-0 COLOR: BLACK
- PIN MATERIAL : PHOSPHOR BRONZE
- PACKAGING
 - = POLY BAGS
 - A = TAPE & REEL + CAP (SEE TA840 FOR PRODUCT AVAILABILITY)
- 9N MIN RETENTION IN EITHER DIRECTION
- TO DETERMINE DIMENSIONS :
N = NUMBER OF POSITIONS PER ROW
EXAMPLE : 8 POS N x 2.54 = 20.32mm
- HOLE DIMENSION TO BE $\phi 1.6 \pm 0.03$ FOR INTERFERENCE FIT APPLICATIONS.
HOLE DIMENSIONS TO BE $\phi 1.95 \pm 0.05$ FOR LOCATION APPLICATION WITH AUTOMATIC PICK AND PLACE MACHINES.
- RoHS COMPATIBLE PRODUCT SPECIFICATIONS

a - PLATING:

- "LF" MEANS THE PRODUCT IS LEAD-FREE, 2µm MINIMUM MATTE TIN OVER 1.27µm MINIMUM NICKEL UNDERPLATE.

b - MANUFACTURING PROCESS COMPATIBILITY

- THE HOUSING WILL WITHSTAND EXPOSURE TO 260°C PEAK TEMPERATURE FOR 30 SECONDES IN A CONVECTION, INFRA-RED OR VAPOR PHASE REFLOW OVEN.

c - LABELING:

- MEETS PACKAGING SPECS AS PER GS-14-920

d - LEGAL STATEMENT: SEE GS-22-008

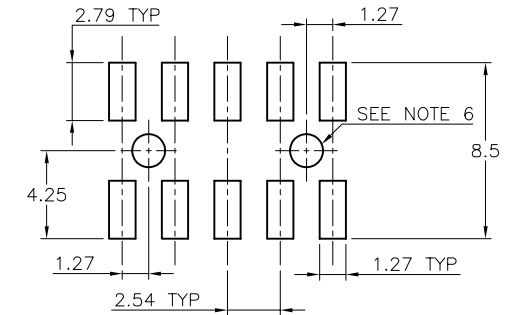
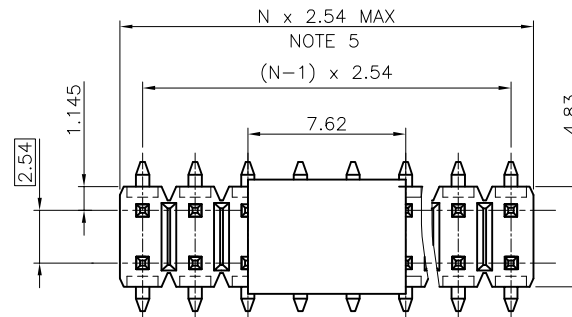

RECOMMENDED PAD LAYOUT

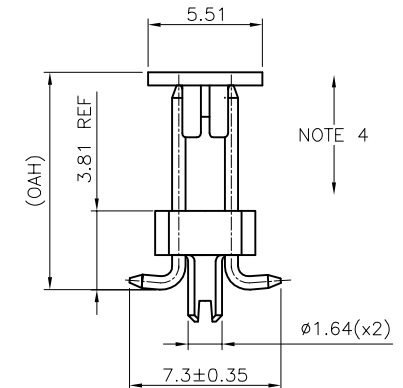
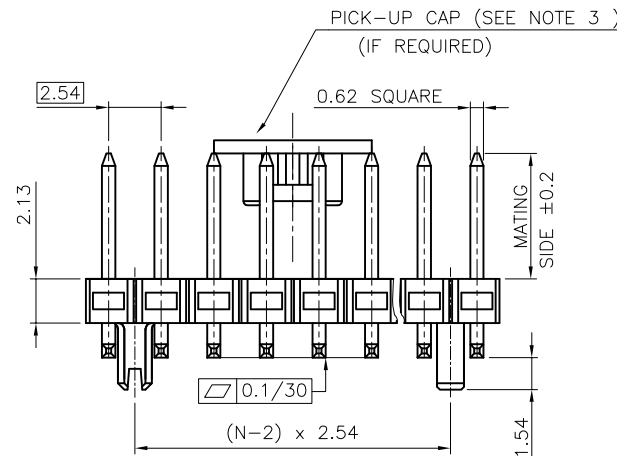

mat'l. code		surface		tolerance		projection		product family	
SEE NOTES		ISO 1302		ISO 406 ISO 1101		mm		BERGSTIK	
ltr	ecn no	dr	date	tolerances unless otherwise specified		mm		title	
H	F08-0148	JCO	08.05.19	angles	x.x ±0.3	mm		UNSHR.HEADER	
J	F11-0031	LMU	11.03.24	linear	x.xx ±0.13	scale 5:1		DR SMT	
					x.xxx ±0.05			dwg no	
D	F04-0362	LMU	04.12.13	dr	D.LE	01.01.24		sheet 1 of 1 size	
E	F06-0208	JCO	06.06.22	enrg	JM.C	01.01.24		98401 A3	
F	F08-0155	JCO	08.04.05	chr	JM.C	01.01.24		type	
G	F08-0170	LMU	08.05.16	appd	JF.N	01.01.24		CUSTOMER Drawing	
sheet index	revision sheet								