

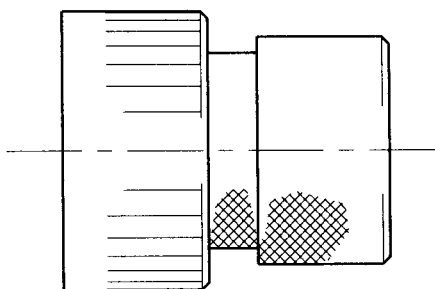

ISSUE	DESCRIPTION	DRAWN	DATE	APPR
A	PRODUCTION ISSUE	IRT	AUG 99	KJW



FIXED ADAPTOR

NOTES

1. THIS PRODUCT IS DESIGNED TO TERMINATE HEAT SHRINKABLE LIPPED MOULDED PARTS 202\*132 OR 222\*132 TO A CONNECTOR - SEE NOTE 4.
2. SEE SHEET 2 FOR PART NUMBERING SYSTEM AND ORDERING INFORMATION.
3. ADAPTOR TO BE PERMANENTLY MARKED WITH CODE IDENTIFICATION NUMBER AND PART NUMBER. (e.g. 06090 SCA131 10-62J).
- ④ ADAPTOR MATES TO CONNECTORS MANUFACTURED TO ROLLS-ROYCE PART NUMBERS ESC001 AND ESC004.
5. FOR ALTERNATIVE MATERIALS/FINISHES - CONTACT RAYCHEM.

SPECIFICATION CONTROL DRAWING		 RAYCHEM LIMITED FARADAY ROAD DORCAN, SWINDON, SN3 5HH WILTS. ENGLAND	
DO NOT SCALE THIS DRAWING		TITLE FIXED ADAPTOR	
DRAWN	IRT	DATE	AUG 99
CHECKED	KJW	DATE	AUG 99
APPROVED	KJW	DATE	AUG 99
PROJECT NO	85135		
THIS DRAWING AND THE INFORMATION SET FORTH HEREON ARE THE PROPERTY OF RAYCHEM AND ARE TO BE HELD IN TRUST AND CONFIDENCE. PUBLICATION, DUPLICATION, DISCLOSURE OR USE FOR ANY OTHER PURPOSE NOT EXPRESSLY AUTHORISED IN WRITING BY RAYCHEM IS PROHIBITED.		CODE IDENT NUMBER	DRAWING NUMBER SCA131
		06090	ISSUE A
		SHEET 1 OF 2	

ELECTRONICS OEM CONTROL STAMP IF THIS STAMP IS RED, THIS IS A CONTROLLED DOCUMENT. IF BLACK, IT IS AN UNCONTROLLED COPY. CHECK FOR REVISION.

ISSUE	DESCRIPTION	DRAWN	DATE	APPR
A	PRODUCTION ISSUE	IRT	AUG 99	KJW

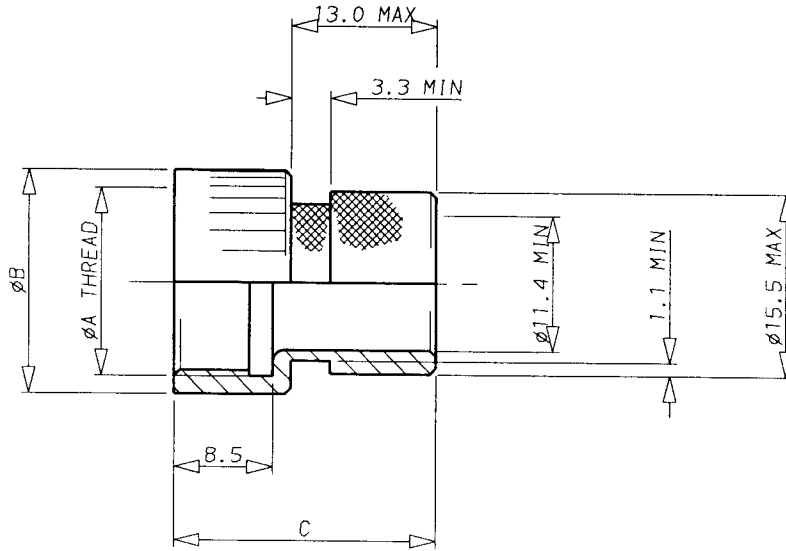

BASE PART NUMBER	ORDER NUMBER	ESC NUMBER		ØA THREAD RH CLASS 2B	ØB MAX	C MAX
		001	003			
SCA131 10-62 J	10	10	10	0.6250"-24 UNEF	19.0	23.0
SCA131 12-62 J	12		12	0.6875"-24 UNEF	20.5	23.0
SCA131 14-62 J	14	12	14	0.7500"-20 UNEF	22.0	33.5
SCA131 16-62 J	16	14	16	0.8750"-20 UNEF	26.0	33.5
SCA131 18-62 J	18	16	18	1.0000"-20 UNEF	29.5	33.5
SCA131 20-62 J	20	20	20	1.1875"-18 UNEF	34.0	33.5
SCA131 22-62 J	22		22	1.2500"-18 UNEF	36.0	33.5
SCA131 24-62 J	24	24	24	1.4375"-18 UNEF	40.5	33.5
SCA131 28-62 J	28		28	1.6250"-18 UNEF	45.0	33.5

PART NUMBERING SYSTEM

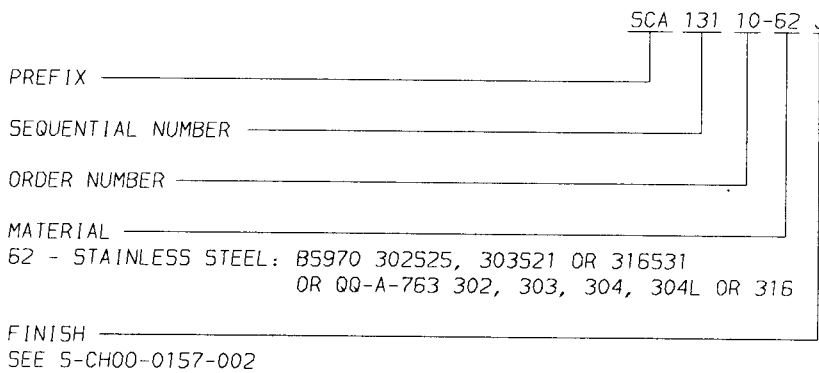

SPECIFICATION CONTROL DRAWING

**Raychem**

RAYCHEM LIMITED  
FARADAY ROAD  
DORCAN, SWINDON, SN3 5HH  
WILTS. ENGLAND

DO NOT SCALE  
THIS DRAWING

THIS DRAWING AND THE INFORMATION SET FORTH HEREON ARE THE PROPERTY OF RAYCHEM AND ARE TO BE HELD IN TRUST AND CONFIDENCE. PUBLICATION, DUPLICATION, DISCLOSURE OR USE FOR ANY OTHER PURPOSE NOT EXPRESSLY AUTHORISED IN WRITING BY RAYCHEM IS PROHIBITED.

TITLE  
FIXED ADAPTOR

DRAWN	IRT	DATE	AUG 99
CHECKED	KJW	DATE	AUG 99
APPROVED	KJW	DATE	AUG 99
PROJECT NO	B5135		

CODE IDENT	DRAWING NUMBER	ISSUE
NUMBER	SCA131	A
06090		

SHEET 2 OF 2

SCA131SCD-2

ELECTRONICS OEM CONTROL STAMP IF THE STAMP IS RED, THIS IS A CONTROLLED DOCUMENT. IF BLACK, IT IS AN UNCONTROLLED COPY. CHECK FOR REVISION.