



*93 KEY LATCH ASSEMBLY

DATE	DRAWN	CHKD	SCALE	DRAWING NUMBER
11-23-82	ACZ		N.T.S.	J-93-10-201-10

REV. LET.	DATE	BY-CHKD	REVISIONS	ASS'Y PART NO
A	4/24/87	03	PRN 01-70-A	93-10-201-10
B	3-21-88	2JS	PRN 93-68	
C	4-20-88	MIK	PRN 16-78	
D	7-14-88	RHS	PRN 93-75	
E	11-16-88	SML	PRN: 93-81	
F	6-9-92	JGK	PRN: 93-137	

* FRAME LOCATION IF ADJUSTABLE KEEPER SUPPLIED WITH ASSEMBLY IS NOT USED.

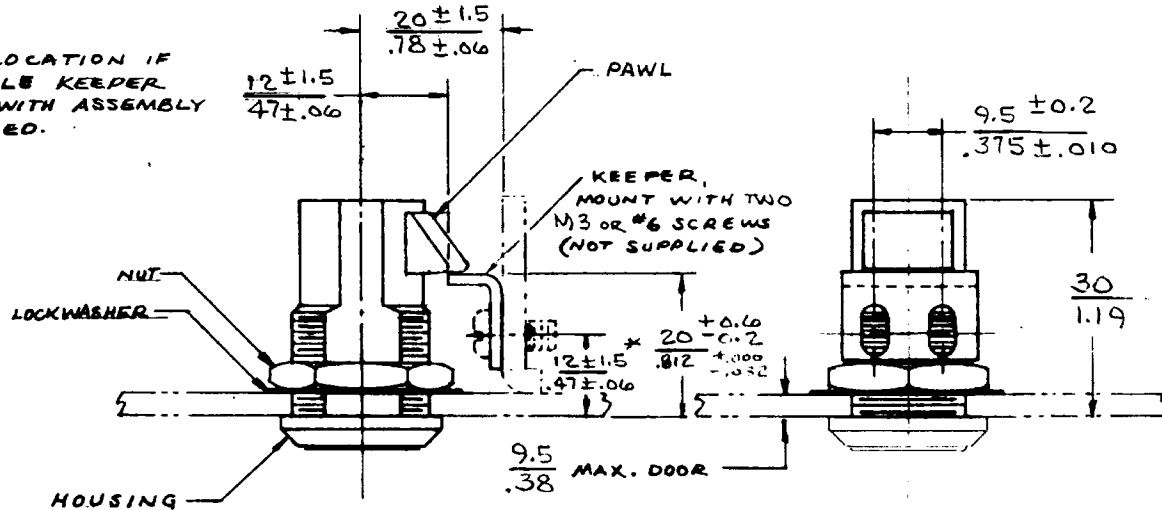

ASSEMBLY PART No. 93-10- 02-10 CONSISTS OF 1 LATCH SUB-ASS'Y. 2 KEYS 1 NUT, 1 LOCKWASHER & 1 KEEPER PACKED IN A PLASTIC BAG.

HOUSING & LOCK - DIE CAST ZINC, BRIGHT CHROME PLATED.

PAWL IS BLACK THERMOPLASTIC

KEEPER & LOCKWASHER ARE STEEL DACROTIZED

NUT IS DIE CAST ZINC, CHEM. PROTECTIVE FILM

KEY TURNS 1/4 TURN IN EITHER DIRECTION TO UNLATCH. KEY IS REMOVEABLE IN CENTER (LATCHED) POSITION ONLY

MAY BE SLAM CLOSED WHEN LOCKED

DOOR PREPARATION

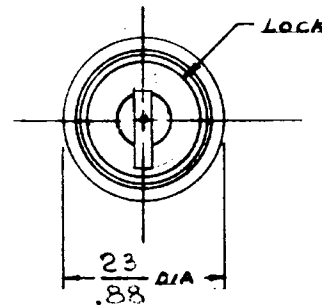
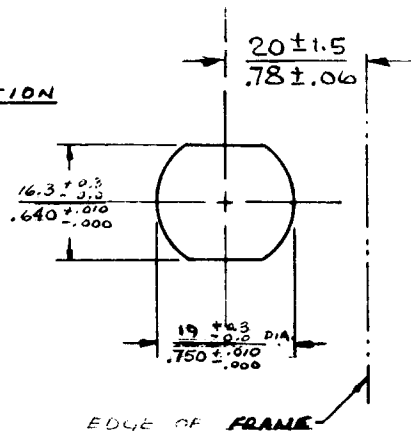

MILLIMETER/INCH

MILLIMETER
INCH

PROPRIETARY ITEM—EXCEPT FOR USES EXPRESSLY GRANTED IN WRITING, INFORMATION DISCLOSED HEREON IS CONFIDENTIAL AND ALL RIGHTS, PATENT AND OTHERWISE, ARE RESERVED BY SOUTHCO, INC.

TOLERANCE UNLESS OTHERWISE NOTED
METRIC MM - TWO PLACE (.XX) ± ONE PLACE (.X) ±
INCH - DECIMALS ± FRACTIONS ± ANGLES ±

DRAWING NUMBER

J-93-10-201-10