

Color: ■ gray

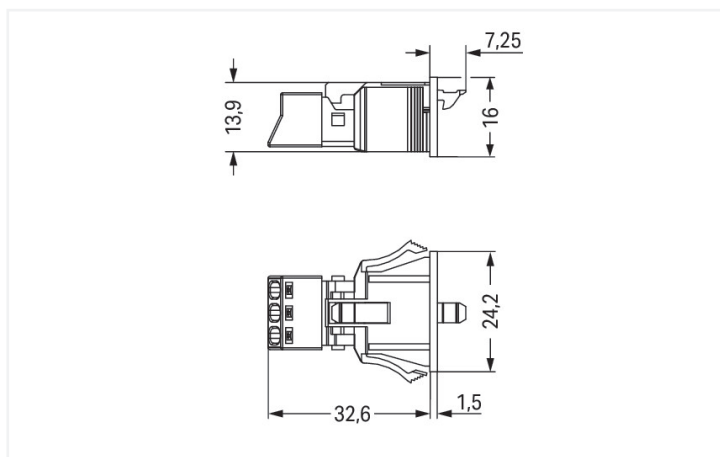

Dimensions in mm

Male connector/plug WINSTA® MINI 3-pole

Use effective pluggable connections instead of laborious screw connections: With the WINSTA® MINI male connector/plug with protection against mismatching. Whether on PCBs, in control cabinets or for connecting lights – pluggable installation connectors from WAGO allow you to establish connections according to a huge variety of requirements in seconds. For greater protection in electrical installations, the pluggable installation connector is provided with mechanical protection against mismatching. Solutions like the WINSTA® MINI pluggable installation connectors with B coding are suitable for process control, such as for lighting or within data networks. Especially where space is tight, our smallest pluggable connection system, WINSTA® MINI, consistently displays its strengths. It saves space, and, thanks to Push-in CAGE CLAMP® spring pressure connection technology, it additionally saves time, since the installation is low-maintenance and can be performed without screw connections.

Lower costs through fast commissioning and elimination of service expenses – solutions from WINSTA® MINI

The WINSTA® Pluggable Connection System is perfectly tailored to the strict requirements of building installation. It makes electrical installation pluggable, and consequently more efficient, more reliable, and error-free. Use of this pre-assembled system reduces assembly times and installation errors at the construction site. Choose durability and quality – with protection type IP20 from WAGO makes the electrical installation of electrical components noticeably easier.

- pluggable installation connectors with protection against mismatching
- easy tool-free operation, a wide range of coding options
- with B coding for controllers such as sun blinds and lighting fixtures
- flexible installation to save space
- convenient installation and commissioning

Notes

Note	The snap-in connectors must be relieved of tensile and transverse forces. A surface finish can influence the edge radius of the cutouts. This may affect the snap-in socket fit, so ensure an adequate fit before use. In addition, the punched edge should be on the inside for punched cutouts. The wings of the snap-in connectors must not be mechanically stressed for a long period before use (e.g., due to a pre-locking position).
Variants:	Other pole markings Other versions (or variants) can be requested from WAGO Sales or configured at https://configurator.wago.com/ .

Electrical data

Ratings per IEC/EN 60664-1		Ratings per IEC/EN – Notes	
Overvoltage category	III III II	Rated current (note)	13 A for 3-pole load
Pollution degree	3 2 2		
Nominal voltage	250 V - -		
Rated surge voltage	4 kV - -		
Rated current	16 A - -		

Approvals per UL 1977		General information	
Rated voltage	600 V	Note on contact resistance	approx. 1 mΩ of contact resistance approx. 0.25 mΩ contact transition plug/socket
Rated current	14 A		

Connection data

Clamping units	3	Connection 1	
Total number of potentials	3	Connection technology	Push-in CAGE CLAMP®
		Actuation type	Operating tool Push-in
		Nominal cross-section	1.5 mm ² / 16 AWG
		Solid conductor	0.25 ... 1.5 mm ² / 22 ... 16 AWG
		Solid conductor; push-in termination	0.75 ... 1.5 mm ² / 20 ... 16 AWG
		Stranded conductor	0.25 ... 1 mm ² / 22 ... 18 AWG
		Fine-stranded conductor	0.25 ... 1.5 mm ² / 22 ... 16 AWG
		Fine-stranded conductor; with insulated ferrule	0.25 ... 0.75 mm ² / 22 ... 20 AWG
		Fine-stranded conductor; with uninsulated ferrule	0.25 ... 0.75 mm ² / 22 ... 20 AWG
		Fine-stranded conductor; with ferrule; push-in termination	0.75 mm ² / 20 AWG
		Strip length	9 mm / 0.35 inches
		Pole number	3
		Conductor entry direction to mating direction	0°

Physical data

Pin spacing	4.4 mm / 0.173 inches
Width	24.2 mm / 0.953 inches
Height	16 mm / 0.63 inches
Depth	39.85 mm / 1.569 inches

Mechanical data

Use	Control technology
Coding	B
Variable coding	No
Marking	3 2 1
Potential marking	3 2 1
Mating force of a plug-in connection	approx. 20 ... 70 N (depending on pole number)
Retention force of a plug-in connection	Locked: > 80 N
Unmating force of a plug-in connection	Unlocked: approx. 20 ... 70 N (depending on pole number)
Number of mating cycles	200, without resistive load
Housing sheet thickness	0.5 ... 2 mm / 0.02 ... 0.079 inches
Mounting type	Snap-in flange
Protection type	IP20; IP40 when mated

Plug-in connection

Contact type (pluggable connector)	Male connector/plug
Connector (connection type)	for conductor
Mismating protection	Yes
Note on mismating protection	All WINSTA® components are 100% protected against mismating when: a.) plugging different numbers of poles b.) plugging while rotated 180 c.) plugging while laterally staggered d.) plugging one pole
Locking lever	Yes
Locking of plug-in connection	Locking lever
Note on locking system	All connectors for mounted installations (snap-in versions for lighting fixtures or devices, all types of PCB and distribution connectors) are factory-equipped with locking levers to ensure plugs and sockets are securely locked. Additional locking levers are only required for flying leads (plug/socket).

Material data

Note (material data)	Information on material specifications can be found here
Color	gray
Cover color	gray
Material group	I
Insulation material (main housing)	Polyamide (PA66)
Flammability class per UL94	V0
Clamping spring material	Chrome-nickel spring steel (CrNi)
Contact material	Copper or copper alloy; surface-treated
Contact Plating	Tin
Fire load	0.178 MJ
Weight	5.5 g

Environmental requirements

Processing temperature	-5 ... +40 °C
Continuous operating temperature	-35 ... +85 °C
Note on continuous operating temperature	Insulating parts for temperatures ≤ 105 °C

Commercial data

Product Group	20 (Winsta)
eCl@ss 10.0	27-44-06-02
eCl@ss 9.0	27-44-06-02
ETIM 8.0	EC002566
ETIM 7.0	EC002566
PU (SPU)	50 (50) pcs
Packaging type	Box
Country of origin	PL
GTIN	4055143427852
Customs tariff number	85366990990

Environmental Product Compliance

RoHS Compliance Status	Compliant, No Exemption
------------------------	-------------------------

Approvals / Certificates

General approvals



Approval	Standard	Certificate Name
CB DEKRA Certification B.V.	IEC 61984	NL-64351
CB DEKRA Certification B.V.	EN 61984	71-112993
cURus Underwriters Laboratories Inc.	UL 1977	E45171
KEMA/KEUR DEKRA Certification B.V.	EN 60320	2148952.04

Declarations of conformity and manufacturer's declarations

Approval	Standard	Certificate Name
EU-Declaration of Confor- mity WAGO GmbH & Co. KG	-	-
UK-Declaration of Confor- mity WAGO GmbH & Co. KG	-	-

Approvals for marine applications



Approval	Standard	Certificate Name
DNV GL Det Norske Veritas, Ger- manischer Lloyd	-	TAE00001Z6
LR Lloyds Register	EN 61535	08/20047 (E2)

Downloads

Environmental Product Compliance

Compliance Search

Environmental Product Compliance 890-753



Documentation

Bid Text

890-753	19.02.2019	xml 2.94 KB	
890-753	30.11.2018	doc 23.00 KB	

CAD/CAE-Data

CAD data

2D/3D Models 890-753



CAE data

EPLAN Data Portal 890-753



WSCAD Universe 890-753



ZUKEN Portal 890-753



1 Compatible Products

1.1 System counterpart

1.1.1 Cable assembly



Item No.: 891-8993/105-103

pre-assembled connecting cable; Eca; Socket/open-ended; 3-pole; Cod. B; 1 m; 1,00 mm²; gray

Item No.: 891-8993/005-103

pre-assembled interconnecting cable; Eca; Socket/plug; 3-pole; Cod. B; 1 m; 1,00 mm²; gray

1.1.2 Female connector/socket



Item No.: 890-243

Socket; 3-pole; Cod. B; 1,50 mm²; gray

1.2 Optional Accessories

1.2.1 Cover

1.2.1.1 Cover



Item No.: 890-643

Lockout cap; 3-pole; for cutouts; Plastic; black

Item No.: 890-693

Lockout cap; 3-pole; for cutouts; Plastic; white

1.2.2 Tool

1.2.2.1 Operating tool



Item No.: 890-383

Operating tool; 3-way; green

Item No.: 210-719

Operating tool; Blade: 2.5 x 0.4 mm; with a partially insulated shaft

Installation Notes

Conductor termination

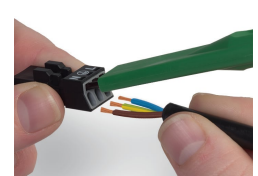
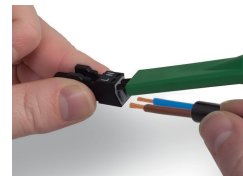
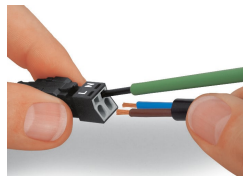

1. Strip length, outer insulation = 30 mm (2-pole), 37 mm (3-pole), 45 mm (4- and 5-pole)
2. Strip length = 9 mm
3. Extended ground conductor = 8 mm

To terminate fine-stranded conductors, open the clamping unit via screwdriver – 2.5 mm blade width – and insert a stripped conductor until it hits the backstop. Terminate solid conductors by simply pushing them in.

To terminate fine-stranded conductors, open clamping units via operating tool (890-382) and insert stripped conductors until they hit backstop. Terminate solid conductors by simply pushing them in.

To terminate fine-stranded conductors, open clamping units via operating tool (890-383) and insert stripped conductors until they hit backstop. Terminate solid conductors by simply pushing them in.

Mismatching protection

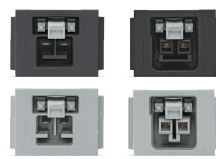
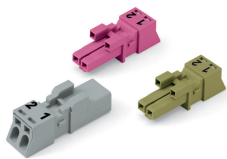

B-coded connectors with different colors can be plugged together.

B-coded connectors (shown in gray) not only differ in color, but also in their design, making them incompatible with other coded connectors.

Important note:

Different colors and/or pole markings are used for circuit identification. Only connectors of the same color and same pole marking must be plugged together.