

Color: ■ black

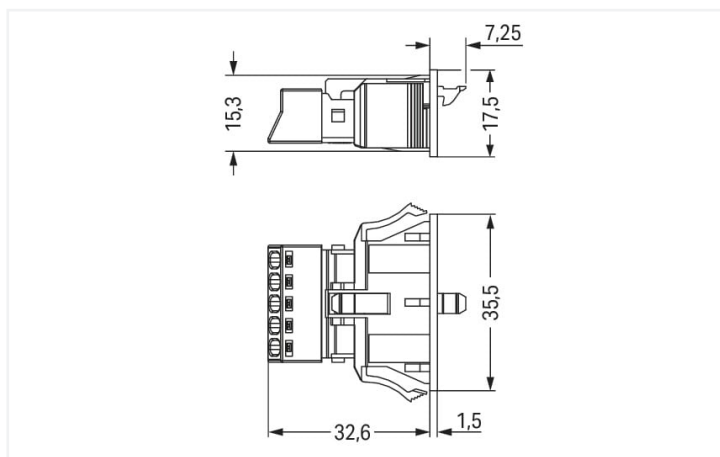

Dimensions in mm

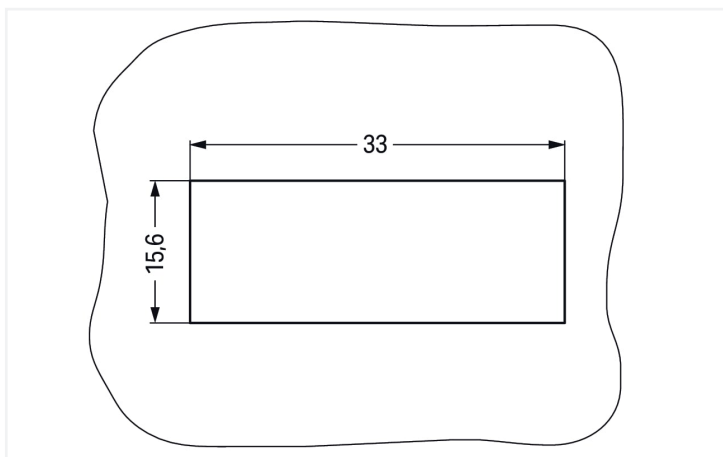

Dimensions in mm
Plate thickness: 0.5 ... 2 mm
Cutout tolerance: + 0.1 mm

Please note!

Female connector/socket WINSTA® MINI with protection type IP40

For signal and power transmission: The WINSTA® MINI female connector/socket with protection type IP40. On PCBs, in control cabinets or for connecting lights – pluggable installation connectors from WAGO allow you to make connections according to a huge variety of requirements in next to no time. The coding options reduce installation errors, allowing fast, maintenance-free wiring of all components. The pluggable installation connector is protected against ingress by solid granular objects with a diameter below 1 mm in accordance with protection type IP40. Thanks to the color coding and mechanical A coding of WINSTA® MINI pluggable installation connectors, you can clearly distinguish different circuits. Especially where space is tight, our smallest pluggable connection system, WINSTA® MINI, conveniently displays its advantageous properties. It is very compact, and, thanks to Push-in CAGE CLAMP® spring pressure connection technology, it also saves time, since the connection is low-maintenance and can be performed without screw connections.

WINSTA® MINI solutions for your electrical installation – protected against mismatching and maintenance-free

The WINSTA® Pluggable Connection System is perfectly tailored to the very strict requirements of building installation. It makes electrical installation pluggable, and consequently more efficient, more reliable, and error-free. Use of this pre-assembled system reduces time spent on assembly and installation errors at the construction site. Now you can also cut installation costs without compromising safety and quality: with protection type IP40 eliminates the need for servicing and prevents unnecessary downtime.

- pluggable installation connectors with protection against mismatching
- consistent IP40 protection
- for any mains application
- exact dimensions
- quick replacement of defective units during ongoing operation

Notes	
Note	The snap-in connectors must be relieved of tensile and transverse forces. A surface finish can influence the edge radius of the cutouts. This may affect the snap-in socket fit, so ensure an adequate fit before use. In addition, the punched edge should be on the inside for punched cutouts. The wings of the snap-in connectors must not be mechanically stressed for a long period before use (e.g., due to a pre-locking position).

Electrical data					
Ratings per	IEC/EN 60664-1			Approvals per	UL 1977
Overvoltage category	III	III	II	Rated voltage	600 V
Pollution degree	3	2	2	Rated current	12 A
Nominal voltage	400 V	-	-		
Rated surge voltage	6 kV	-	-		
Rated current	13 A	-	-		

General information	
Note on contact resistance	approx. 1 mΩ of contact resistance approx. 0.25 mΩ contact transition plug/socket

Connection data	
Clamping units	5
Total number of potentials	5
Connection 1	
Connection technology	Push-in CAGE CLAMP®
Actuation type	Operating tool Push-in
Nominal cross-section	1.5 mm² / 16 AWG
Solid conductor	0.25 ... 1.5 mm² / 22 ... 16 AWG
Solid conductor; push-in termination	0.75 ... 1.5 mm² / 20 ... 16 AWG
Stranded conductor	0.25 ... 1 mm² / 22 ... 18 AWG
Fine-stranded conductor	0.25 ... 1.5 mm² / 22 ... 16 AWG
Fine-stranded conductor; with insulated ferrule	0.25 ... 0.75 mm² / 22 ... 20 AWG

Connection 1

Fine-stranded conductor; with uninsulated ferrule	0.25 ... 0.75 mm ² / 22 ... 20 AWG
Fine-stranded conductor; with ferrule; push-in termination	0.75 mm ² / 20 AWG
Strip length	9 mm / 0.35 inches
Pole number	5
Conductor entry direction to mating direction	0 °

Physical data

Pin spacing	4.4 mm / 0.173 inches
Width	35.5 mm / 1.398 inches
Height	17.5 mm / 0.689 inches
Depth	39.85 mm / 1.569 inches

Mechanical data

Use	General mains applications
Coding	A
Variable coding	No
Marking	N 1 2 3
Potential marking	N 1 2 3
Mating force of a plug-in connection	approx. 20 ... 70 N (depending on pole number)
Retention force of a plug-in connection	Locked: > 80 N
Unmating force of a plug-in connection	Unlocked: approx. 20 ... 70 N (depending on pole number)
Number of mating cycles	200, without resistive load
Housing sheet thickness	0.5 ... 2 mm / 0.02 ... 0.079 inches
Mounting type	Snap-in flange
Protection type	IP40

Plug-in connection

Contact type (pluggable connector)	Female connector/socket
Connector (connection type)	for conductor
Mismating protection	Yes
Note on mismating protection	All <i>WINSTA</i> ® components are 100% protected against mismating when: a.) plugging different numbers of poles b.) plugging while rotated 180 c.) plugging while laterally staggered d.) plugging one pole
Locking lever	Yes
Locking of plug-in connection	Locking lever
Note on locking system	All connectors for mounted installations (snap-in versions for lighting fixtures or devices, all types of PCB and distribution connectors) are factory-equipped with locking levers to ensure plugs and sockets are securely locked. Additional locking levers are only required for flying leads (plug/socket).

Material data

Note (material data)	Information on material specifications can be found here
Color	black
Cover color	gray
Material group	I
Insulation material (main housing)	Polyamide (PA66)
Flammability class per UL94	V0
Clamping spring material	Chrome-nickel spring steel (CrNi)
Contact material	Copper or copper alloy; surface-treated
Contact Plating	Tin
Fire load	0.261 MJ
Weight	9 g

Environmental requirements

Processing temperature	-5 ... +40 °C
Continuous operating temperature	-35 ... +85 °C
Note on continuous operating temperature	Insulating parts for temperatures ≤ 105 °C

Commercial data

Product Group	20 (Winsta)
eCl@ss 10.0	27-44-06-02
eCl@ss 9.0	27-44-06-02
ETIM 9.0	EC002566
ETIM 8.0	EC002566
PU (SPU)	50 (50) pcs
Packaging type	Box
Country of origin	PL
GTIN	4045454233433
Customs tariff number	85366990990

Environmental Product Compliance

RoHS Compliance Status	Compliant, No Exemption
------------------------	-------------------------

Approvals / Certificates

General approvals



Approval	Standard	Certificate Name
CCA DEKRA Certification B.V.	EN 61535	71-123231
CCA DEKRA Certification B.V.	IEC 61535	NL-85020
cURus Underwriters Laboratories Inc.	UL 1977	E45171

Declarations of conformity and manufacturer's declarations

Approval	Standard	Certificate Name
EU-Declaration of Confor- mity WAGO GmbH & Co. KG	-	-
UK-Declaration of Confor- mity WAGO GmbH & Co. KG	-	-

Approvals for marine applications



Approval	Standard	Certificate Name
ABS American Bureau of Ship- ping	Steel Vessel Rules	19-HG1869855-PDA
DNV GL Det Norske Veritas, Ger- manischer Lloyd	-	TAE00001Z6
LR Lloyds Register	EN 61535	08/20047 (E2)

Downloads

Environmental Product Compliance

Compliance Search
Environmental Product Compliance 890-705

Documentation

Bid Text			
890-705	19.02.2019	xml 2.89 KB	
890-705	30.11.2018	doc 23.00 KB	

CAD/CAE-Data

CAD data
2D/3D Models 890-705

CAE data
EPLAN Data Portal 890-705
WSCAD Universe 890-705
ZUKEN Portal 890-705

1 Compatible Products

1.1 System counterpart

1.1.1 Cable assembly



Item No.: 891-8995/206-101
pre-assembled connecting cable; Eca;
Plug/open-ended; 5-pole; Cod. A; H05VV-
F 5G 1.5 mm²; 1 m; 1,50 mm²; black

Item No.: 891-8995/006-101
pre-assembled interconnecting cable;
Eca; Socket/plug; 5-pole; Cod. A; H05VV-
F 5G 1.5 mm²; 1 m; 1,50 mm²; black

1.1.2 Male connector/plug



Item No.: 890-215

Plug; 5-pole; Cod. A; 1,50 mm²; black

Item No.: 890-115

Plug; with strain relief housing; 5-pole; 1,50 mm²; black

1.2 Optional Accessories

1.2.1 Cover

1.2.1.1 Cover



Item No.: 770-643

Lockout cap; 3-pole; for cutouts; Plastic; black

Item No.: 770-693

Lockout cap; 3-pole; for cutouts; Plastic; white

1.2.2 Tool

1.2.2.1 Operating tool



Item No.: 890-385

Operating tool; 5-way; green

Item No.: 210-719

Operating tool; Blade: 2.5 x 0.4 mm; with a partially insulated shaft

Installation Notes

Conductor termination

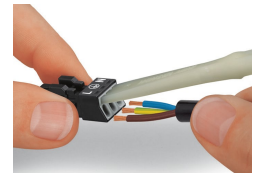
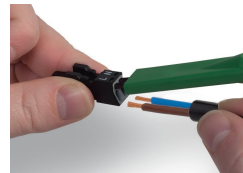
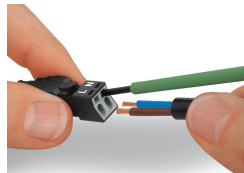
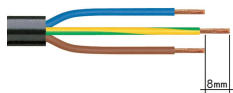

1. Strip length, outer insulation = 30 mm (2-pole), 37 mm (3-pole), 45 mm (4- and 5-pole)
2. Strip length = 9 mm
3. Extended ground conductor = 8 mm

To terminate fine-stranded conductors, open the clamping unit via screwdriver – 2.5 mm blade width – and insert a stripped conductor until it hits the backstop. Terminate solid conductors by simply pushing them in.

To terminate fine-stranded conductors, open clamping units via operating tool (890-382) and insert stripped conductors until they hit backstop. Terminate solid conductors by simply pushing them in.