



✓ RoHS

89 Compensated

SPECIFICATIONS

- ◆ **316L SS Pressure Sensor**
- ◆ **High Pressure**
- ◆ **0 - 100mV Output**
- ◆ **Absolute and Sealed Gage**

The 89 compensated is a small profile, media compatible, piezoresistive silicon pressure sensor packaged in a 316L stainless steel housing. The 89 compensated features 5/16-32 UNEF threads and can be welded in place. It can also be packaged in a variety of threaded fittings such as 1/4 and 1/8NPT, 1/4BSP as well as custom process fittings. Contact factory for threaded fitting options.

The 89 compensated is designed for high pressure OEM applications where compatibility with corrosive media is required. The sensing package utilizes silicon oil to transfer pressure from the 316L stainless steel diaphragm to the sensing element. A ceramic substrate is attached to the package that contains laser-trimmed resistors for temperature compensated and offset correction. An additional laser trimmed resistor is included which can be used to adjust an external differential amplifier and provide span interchangeability to within $\pm 1\%$.

Please refer to the 89 uncompensated and constant voltage datasheets for more information on different features of the 89.

FEATURES

- ◆ Threaded Process Fittings or O-Ring Mount
- ◆ -40°C to +125°C Operating Temperature Range
- ◆ ±0.25% Pressure Non Linearity
- ◆ Solid State Reliability

APPLICATIONS

- ◆ Hydraulic Controls
- ◆ Process Control
- ◆ Pressure Calibrators
- ◆ Refrigeration/Compressors

STANDARD RANGES

Range	psia	psis
0 to 1000	◆	◆
0 to 3000	◆	◆
0 to 5000	◆	◆
0 to 10K	◆	◆

PERFORMANCE SPECIFICATIONS

Supply Current: 1.5 mA

Ambient Temperature: 25°C (unless otherwise specified)

PARAMETERS	MIN	TYP	MAX	UNITS	NOTES
Full Scale Output Span	75	125	210	mV	1
Zero Pressure Output	-1.0		1.0	mV	
Pressure Non Linearity	-0.25		0.25	%Span	2
Pressure Hysteresis	-0.1		0.1	%Span	
Input Resistance	3000	4000	5000	Ω	
Output Resistance	4000		6000	Ω	
Temperature Error – Span	-0.75		0.75	%Span	3
Temperature Error – Zero	-0.75		0.75	%Span	3
Thermal Hysteresis – Span	-0.25		0.25	%Span	3
Thermal Hysteresis – Zero	-0.25		0.25	%Span	3
Long Term Stability – Zero/Span		±0.1		%Span/yr	
Supply Current	0.5	1.5	2.0	mA	
Output Load Resistance	5			MΩ	4
Insulation Resistance (50Vdc)	50			MΩ	5
Pressure Overload			3X	Rated	6
Pressure Burst			4X	Rated	7
Operating Temperature	-40		+125	°C	8
Compensated Temperature Range	-20		+85	°C	3
Storage Temperature	-50		+125	°C	8
Weight			9	grams	
Media – Pressure Port	Liquids and Gases compatible with 316/316L Stainless Steel				

Notes

1. Calculated at FSP, 3000psi and 5000psi parts are tested at 2500psi.
2. Best fit straight line between 0 and FSP.
3. Over the compensated temperature range with respect to +25°C.
4. Load resistance to reduce measurement errors due to output loading.
5. Between case and sensing element.
6. 3X or 20,000psi, whichever is less.
7. 4X or 30,000psi, whichever is less. The maximum pressure that can be applied to a transducer without rupture of either the sensing element or transducer.
8. Maximum temperature range for this product with standard cable and connector is -20°C to +105°C.

DIMENSIONS

DIMENSIONS ARE IN INCHES [mm]

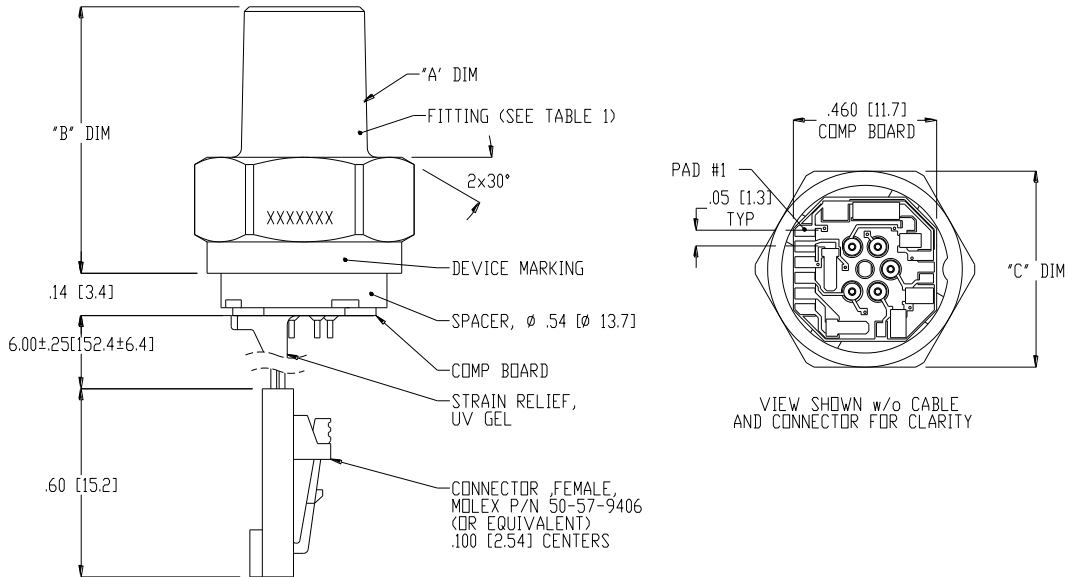
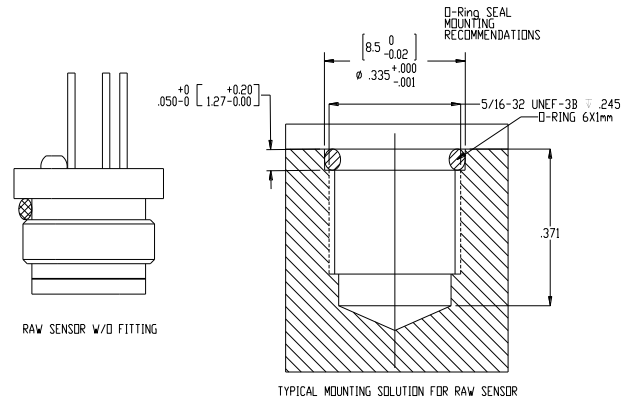
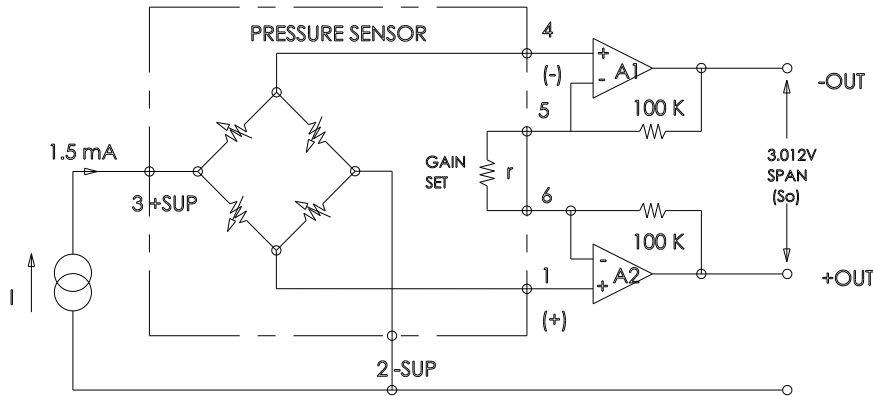

TABLE 1: FITTING DIMENSION				
FITTING TYPE	MEAS P/N	"A" DIM	"B" DIM	"C" DIM
1	IC-D00364	1/4-18 NPT	.93[23.6]	7/8 [22.2] HEX
2	IC-D00365	1/8-27 NPT	.91[23.1]	7/8 [22.2] HEX
3	IC-D00366	7/16-20 UNF	.77[19.6]	7/8 [22.2] HEX
4	IC-D00348	1/4-18 NPT	.82[20.8]	5/8 [15.9] HEX
5	IC-D00367	1/4-19 BSP	.82[20.8]	3/4 [19.0] HEX
8	IC-D00349	1/8-27 NPT	.69[17.5]	5/8 [15.9] HEX
9	IC-D00368	1/4-19 BSP	.89[22.6]	7/8 [22.2] HEX
0	NO FITTING, CERAMIC NOT SOLDERED ON PINS BUT ATTACHED TOGETHER FOR SHIPPING			
NOTE: FITTING TYPE "4" ASSEMBLY SHOWN ALL DIMS ARE FOR REFERENCE ONLY				



CONNECTIONS



PAD /WIRE NO	FUNCTION
1	+OUT
2	-EX
3	+EX
4	-OUT
5,6	GAIN

ORDERING INFORMATION

89 - 01K A - 0 P

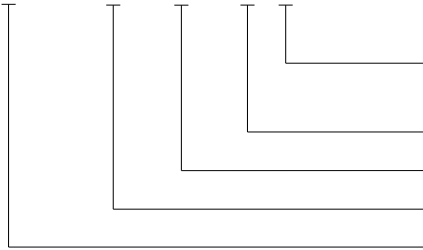

Electrical (P = Solder Pads, R = Ribbon Cable, C = Cable w/ Connector)

Fitting Type

Type (A = Absolute, S = Sealed Gage)

Pressure Range

Model

NORTH AMERICA

Measurement Specialties, Inc.,
a TE Connectivity Company
Tel: 800-522-6752
Email: customercare.frm@te.com

EUROPE

Measurement Specialties (Europe), Ltd.,
a TE Connectivity Company
Tel: 800-440-5100
Email: customercare.lcsb@te.com

ASIA

Measurement Specialties (China), Ltd.,
a TE Connectivity Company
Tel: 0400-820-6015
Email: customercare.shzn@te.com

TE.com/sensorsolutions

Measurement Specialties, Inc., a TE Connectivity company.

Measurement Specialties, TE Connectivity, TE Connectivity (logo) and EVERY CONNECTION COUNTS are trademarks. All other logos, products and/or company names referred to herein might be trademarks of their respective owners.

The information given herein, including drawings, illustrations and schematics which are intended for illustration purposes only, is believed to be reliable. However, TE Connectivity makes no warranties as to its accuracy or completeness and disclaims any liability in connection with its use. TE Connectivity's obligations shall only be as set forth in TE Connectivity's Standard Terms and Conditions of Sale for this product and in no case will TE Connectivity be liable for any incidental, indirect or consequential damages arising out of the sale, resale, use or misuse of the product. Users of TE Connectivity products should make their own evaluation to determine the suitability of each such product for the specific application.

© 2015 TE Connectivity Ltd. family of companies All Rights Reserved.