

LM107QML

LM107QML Operational Amplifier



Literature Number: SNOSAP0A

Operational Amplifier

General Description

The LM107 is a complete, general purpose operational amplifier, with the necessary frequency compensation built into the chip. Advanced processing techniques make the input currents a factor of ten lower than industry standards such as the 709. Yet, they are a direct, plug-in replacement for the 709, LM101A and 741. The LM107 offers the features of the LM101A, which makes its application nearly foolproof. In addition, the device provides better accuracy and lower noise in high impedance circuitry. The low input currents also make it particularly well suited for long interval integrators or timers, sample and hold circuits and low frequency waveform generators. Further, replacing circuits where matched transistor pairs buffer the inputs of conventional IC op amps, it can give lower offset voltage and drift at a lower cost.

Features

- Offset voltage 3 mV maximum over temperature
- Input current 100 nA maximum over temperature
- Offset current 20 nA maximum over temperature

Ordering Information

NS Part Number	SMD Part Number	NS Package Number	Package Description
LM107H/883	5962-8958901GA	H08C	8LD Metal Can

Connection Diagram

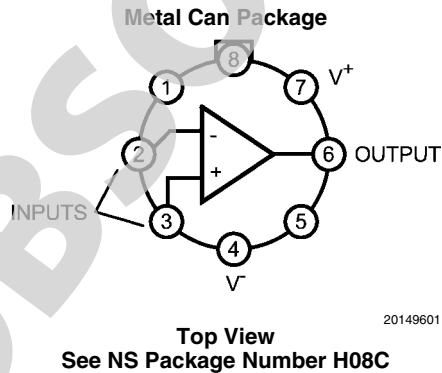

Note: Pin 4 connected to case.

Schematic Diagram

(Pin connections shown are for metal can)

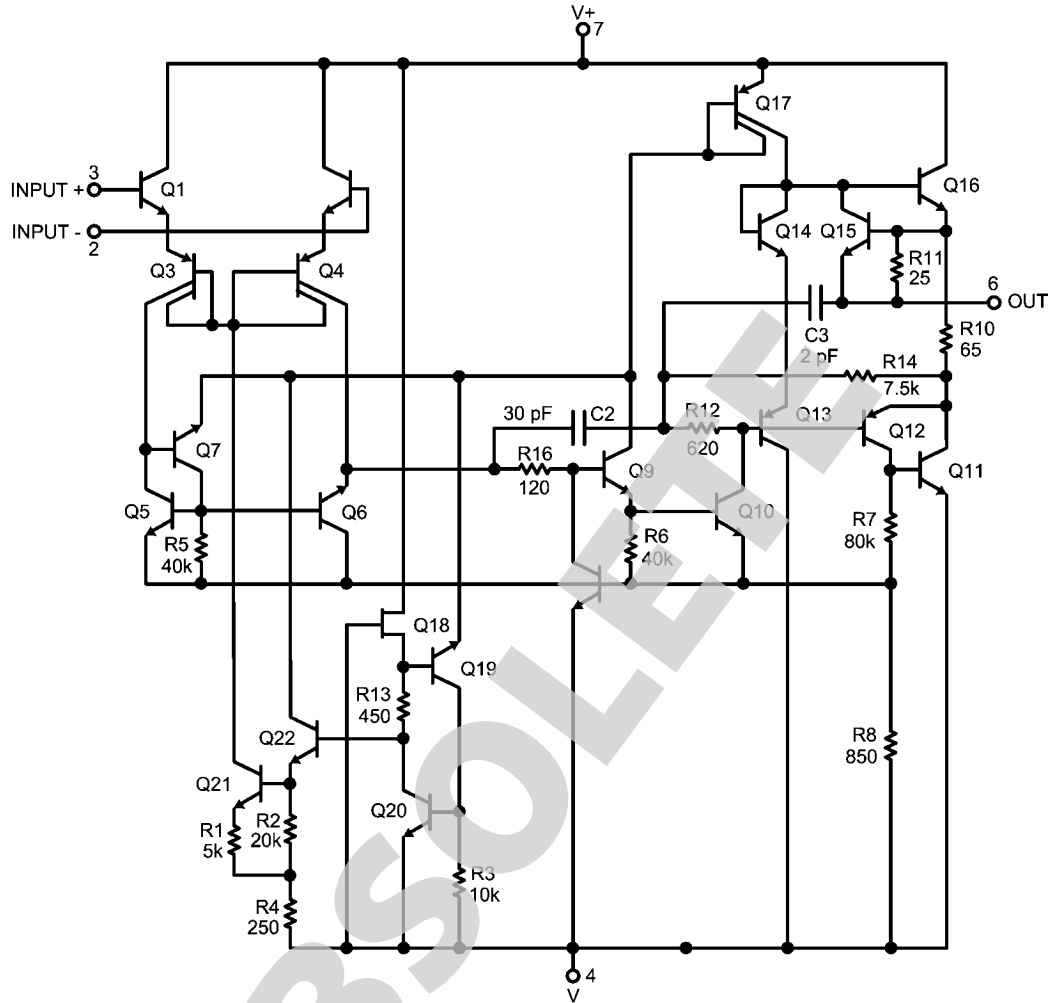

20149602

Note: For Performance Characteristics or Typical Applications graphs, Refer to Commercial Data Sheet.

Absolute Maximum Ratings *(Note 1)*

Supply Voltage	±22V
Power Dissipation <i>(Note 2, Note 3)</i>	500 mW
Differential Input Voltage	±30V
Input Voltage <i>(Note 3)</i>	±15V
Output Short Circuit Duration	Continuous
Operating Temperature Range (T_A)	$-55^{\circ}\text{C} \leq T_A \leq +125^{\circ}\text{C}$
Storage Temperature Range	$-65^{\circ}\text{C} \leq T_A \leq +150^{\circ}\text{C}$
Lead Temperature (Soldering, 10 seconds)	260°C
ESD Tolerance <i>(Note 4)</i>	1000V

Quality Conformance Inspection

MIL-STD-883, Method 5005 - Group A

Subgroup	Description	Temp (°C)
1	Static tests at	+25
2	Static tests at	+125
3	Static tests at	-55
4	Dynamic tests at	+25
5	Dynamic tests at	+125
6	Dynamic tests at	-55
7	Functional tests at	+25
8A	Functional tests at	+125
8B	Functional tests at	-55
9	Switching tests at	+25
10	Switching tests at	+125
11	Switching tests at	- 55

LM107 Electrical Characteristics

DC Parameters

The following conditions apply, unless otherwise specified. $V_{CC} = \pm 20V$, $V_{CM} = 0V$, $R_S = 50\Omega$

Symbol	Parameter	Conditions	Notes	Min	Max	Unit	Sub-groups		
V_{IO}	Input Offset Voltage	$V_{CM} = \pm 15V$		-2	2	mV	1		
				-3	3	mV	2, 3		
				-2	2	mV	1		
				-3	3	mV	2, 3		
		$V_{CC} = \pm 5V$		-2	2	mV	1		
				-3	3	mV	2, 3		
I_{IO}	Input Offset Current	$V_{CM} = \pm 15V$		-10	10	nA	1		
				-20	20	nA	2, 3		
				-10	10	nA	1		
				-20	20	nA	2, 3		
		$V_{CC} = \pm 5V$		-10	10	nA	1		
				-20	20	nA	2, 3		
$\pm I_{IB}$	Input Bias Current	$V_{CM} = \pm 15V$		1	75	nA	1		
				1	100	nA	2, 3		
				1	75	nA	1		
				1	100	nA	2, 3		
		$V_{CC} = \pm 5V$		1	75	nA	1		
				1	100	nA	2, 3		
I_{CC}	Supply Current				3	mA	1		
					2.5	mA	2		
					3.5	mA	3		
$-I_{OS}$	Short Circuit Current			7	45	mA	1		
				5	45	mA	2		
				7	50	mA	3		
$+I_{OS}$	Short Circuit Current			-45	-7	mA	1		
				-45	-5	mA	2		
				-50	-7	mA	3		
$+PSRR$	Supply Voltage Rejection Ratio	$+V_{CC} = 20V$ to $5V$, $-V_{CC} = -20V$		80		dB	1, 2, 3		
$-PSRR$	Supply Voltage Rejection Ratio	$-V_{CC} = -20V$ to $-5V$, $+V_{CC} = 20V$		80		dB	1, 2, 3		
CMRR	Common Mode rejection Ratio	$-15V \leq V_{CM} \leq +15V$		80		dB	1, 2, 3		
R_{IN}	Input Resistance			1.5		M Ω	1		
V_{IR}	Input Voltage Range		(Note 5)	-15	+15	V	1, 2, 3		
$-A_{VS}$	Large Signal Voltage Gain	$V_{CC} = \pm 15V$, $V_{OUT} = 0$ to $-12V$, $R_L = 10K\Omega$		50		V/mV	4		
		$V_{CC} = \pm 15V$, $V_{OUT} = 0$ to $-12V$, $R_L = 10K\Omega$		25		V/mV	5, 6		
		$V_{CC} = \pm 15V$, $V_{OUT} = 0$ to $-10V$, $R_L = 2K\Omega$		50		V/mV	4		
		$V_{CC} = \pm 15V$, $V_{OUT} = 0$ to $-10V$, $R_L = 2K\Omega$		25		V/mV	5, 6		

Symbol	Parameter	Conditions	Notes	Min	Max	Unit	Sub-groups
+A _{VS}	Large Signal Voltage Gain	V _{CC} = ±15V, V _{OUT} = 0 to 12V, R _L = 10KΩ		50		V/mV	4
		V _{CC} = ±15V, V _{OUT} = 0 to 12V, R _L = 10KΩ		25		V/mV	5, 6
		V _{CC} = ±15V, V _{OUT} = 0 to 10V, R _L = 2KΩ		50		V/mV	4
		V _{CC} = ±15V, V _{OUT} = 0 to 10V, R _L = 2KΩ		25		V/mV	5, 6
+V _{OP}	Output Voltage Swing	V _{CC} = ±15V, R _L = 10KΩ		12		V	4, 5, 6
		V _{CC} = ±15V, R _L = 2KΩ		10		V	4, 5, 6
		R _L = 10KΩ		16		V	4, 5, 6
		R _L = 2KΩ		15		V	4, 5, 6
-V _{OP}	Output Voltage Swing	V _{CC} = ±15V, R _L = 10KΩ			-12	V	4, 5, 6
		V _{CC} = ±15V, R _L = 2KΩ			-10	V	4, 5, 6
		R _L = 10KΩ			-16	V	4, 5, 6
		R _L = 2KΩ			-15	V	4, 5, 6

AC Parameters

The following conditions apply, unless otherwise specified. V_{CC} = ±20V, V_{CM} = 0V, R_S = 50KΩ

Symbol	Parameter	Conditions	Notes	Min	Max	Unit	Sub-groups
+S _R	Slew Rate	V _{IN} = -5V to +5V, A _V = 1, R _L = 2KΩ		0.2		V/μS	7
-S _R	Slew Rate	V _{IN} = +5V to -5V, A _V = 1, R _L = 2KΩ		0.2		V/μS	7
GBW	Gain Bandwidth	V _{IN} = 50mV _{RMS} , f = 20KHZ, R _L = 2KΩ		250		KHZ	7

Note 1: Absolute Maximum Ratings indicate limits beyond which damage to the device may occur. Operating Ratings indicate conditions for which the device is functional, but do not guarantee specific performance limits. For guaranteed specifications and test conditions, see the Electrical Characteristics. The guaranteed specifications apply only for the test conditions listed. Some performance characteristics may degrade when the device is not operated under the listed test conditions.

Note 2: The maximum power dissipation must be derated at elevated temperatures and is dictated by T_{Jmax} (maximum junction temperature), θ_{JA} (package junction to ambient thermal resistance), and T_A (ambient temperature). The maximum allowable power dissipation at any temperature is P_{Dmax} = (T_{Jmax} - T_A) / θ_{JA} or the number given in the Absolute Maximum Ratings, whichever is lower.

Note 3: For supply voltages less than ±15V, the absolute maximum input voltage is equal to the supply voltage.

Note 4: Human body model, 1.5 KΩ in series with 100 pF.

Note 5: Guaranteed by CMRR.

Revision History

Date Released	Revision	Section	Originator	Changes
05/09/05	A	New Release, Corporate format	R. Malone	New Release, Corporate format. 1 MDS data sheet converted into a Corp. data sheet format. Following MDS data sheets will be Archived MNLM107-X, Rev. 0CL
	B	Obsolete Data Sheet	Cullum	End Of Life on Product/NSID Dec. 2005

OBSOLETE

Physical Dimensions inches (millimeters) unless otherwise noted

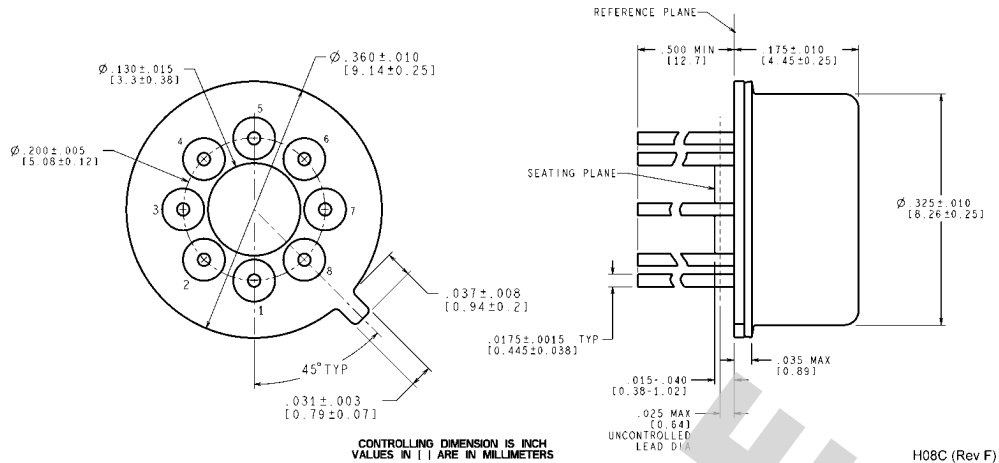

**Metal Can (H)
NS Package Number H08C**

OBSOLETE

Notes

For more National Semiconductor product information and proven design tools, visit the following Web sites at:
www.national.com

Products		Design Support	
Amplifiers	www.national.com/amplifiers	WEBENCH® Tools	www.national.com/webench
Audio	www.national.com/audio	App Notes	www.national.com/appnotes
Clock and Timing	www.national.com/timing	Reference Designs	www.national.com/refdesigns
Data Converters	www.national.com/adc	Samples	www.national.com/samples
Interface	www.national.com/interface	Eval Boards	www.national.com/evalboards
LVDS	www.national.com/lvds	Packaging	www.national.com/packaging
Power Management	www.national.com/power	Green Compliance	www.national.com/quality/green
Switching Regulators	www.national.com/switchers	Distributors	www.national.com/contacts
LDOs	www.national.com/ldo	Quality and Reliability	www.national.com/quality
LED Lighting	www.national.com/led	Feedback/Support	www.national.com/feedback
Voltage References	www.national.com/vref	Design Made Easy	www.national.com/easy
PowerWise® Solutions	www.national.com/powerwise	Applications & Markets	www.national.com/solutions
Serial Digital Interface (SDI)	www.national.com/sdi	Mil/Aero	www.national.com/milaero
Temperature Sensors	www.national.com/tempensors	SolarMagic™	www.national.com/solarmagic
PLL/VCO	www.national.com/wireless	PowerWise® Design University	www.national.com/training

THE CONTENTS OF THIS DOCUMENT ARE PROVIDED IN CONNECTION WITH NATIONAL SEMICONDUCTOR CORPORATION ("NATIONAL") PRODUCTS. NATIONAL MAKES NO REPRESENTATIONS OR WARRANTIES WITH RESPECT TO THE ACCURACY OR COMPLETENESS OF THE CONTENTS OF THIS PUBLICATION AND RESERVES THE RIGHT TO MAKE CHANGES TO SPECIFICATIONS AND PRODUCT DESCRIPTIONS AT ANY TIME WITHOUT NOTICE. NO LICENSE, WHETHER EXPRESS, IMPLIED, ARISING BY ESTOPPEL OR OTHERWISE, TO ANY INTELLECTUAL PROPERTY RIGHTS IS GRANTED BY THIS DOCUMENT.

TESTING AND OTHER QUALITY CONTROLS ARE USED TO THE EXTENT NATIONAL DEEMS NECESSARY TO SUPPORT NATIONAL'S PRODUCT WARRANTY. EXCEPT WHERE MANDATED BY GOVERNMENT REQUIREMENTS, TESTING OF ALL PARAMETERS OF EACH PRODUCT IS NOT NECESSARILY PERFORMED. NATIONAL ASSUMES NO LIABILITY FOR APPLICATIONS ASSISTANCE OR BUYER PRODUCT DESIGN. BUYERS ARE RESPONSIBLE FOR THEIR PRODUCTS AND APPLICATIONS USING NATIONAL COMPONENTS. PRIOR TO USING OR DISTRIBUTING ANY PRODUCTS THAT INCLUDE NATIONAL COMPONENTS, BUYERS SHOULD PROVIDE ADEQUATE DESIGN, TESTING AND OPERATING SAFEGUARDS.

EXCEPT AS PROVIDED IN NATIONAL'S TERMS AND CONDITIONS OF SALE FOR SUCH PRODUCTS, NATIONAL ASSUMES NO LIABILITY WHATSOEVER, AND NATIONAL DISCLAIMS ANY EXPRESS OR IMPLIED WARRANTY RELATING TO THE SALE AND/OR USE OF NATIONAL PRODUCTS INCLUDING LIABILITY OR WARRANTIES RELATING TO FITNESS FOR A PARTICULAR PURPOSE, MERCHANTABILITY, OR INFRINGEMENT OF ANY PATENT, COPYRIGHT OR OTHER INTELLECTUAL PROPERTY RIGHT.

LIFE SUPPORT POLICY

NATIONAL'S PRODUCTS ARE NOT AUTHORIZED FOR USE AS CRITICAL COMPONENTS IN LIFE SUPPORT DEVICES OR SYSTEMS WITHOUT THE EXPRESS PRIOR WRITTEN APPROVAL OF THE CHIEF EXECUTIVE OFFICER AND GENERAL COUNSEL OF NATIONAL SEMICONDUCTOR CORPORATION. As used herein:

Life support devices or systems are devices which (a) are intended for surgical implant into the body, or (b) support or sustain life and whose failure to perform when properly used in accordance with instructions for use provided in the labeling can be reasonably expected to result in a significant injury to the user. A critical component is any component in a life support device or system whose failure to perform can be reasonably expected to cause the failure of the life support device or system or to affect its safety or effectiveness.

National Semiconductor and the National Semiconductor logo are registered trademarks of National Semiconductor Corporation. All other brand or product names may be trademarks or registered trademarks of their respective holders.

Copyright© 2010 National Semiconductor Corporation

For the most current product information visit us at www.national.com



www.national.com

**National Semiconductor
Americas Technical
Support Center**

Email: support@nsc.com
Tel: 1-800-272-9959

**National Semiconductor Europe
Technical Support Center**

Email: europe.support@nsc.com

**National Semiconductor Asia
Pacific Technical Support Center**

Email: ap.support@nsc.com

**National Semiconductor Japan
Technical Support Center**

Email: jpn.feedback@nsc.com

IMPORTANT NOTICE

Texas Instruments Incorporated and its subsidiaries (TI) reserve the right to make corrections, modifications, enhancements, improvements, and other changes to its products and services at any time and to discontinue any product or service without notice. Customers should obtain the latest relevant information before placing orders and should verify that such information is current and complete. All products are sold subject to TI's terms and conditions of sale supplied at the time of order acknowledgment.

TI warrants performance of its hardware products to the specifications applicable at the time of sale in accordance with TI's standard warranty. Testing and other quality control techniques are used to the extent TI deems necessary to support this warranty. Except where mandated by government requirements, testing of all parameters of each product is not necessarily performed.

TI assumes no liability for applications assistance or customer product design. Customers are responsible for their products and applications using TI components. To minimize the risks associated with customer products and applications, customers should provide adequate design and operating safeguards.

TI does not warrant or represent that any license, either express or implied, is granted under any TI patent right, copyright, mask work right, or other TI intellectual property right relating to any combination, machine, or process in which TI products or services are used. Information published by TI regarding third-party products or services does not constitute a license from TI to use such products or services or a warranty or endorsement thereof. Use of such information may require a license from a third party under the patents or other intellectual property of the third party, or a license from TI under the patents or other intellectual property of TI.

Reproduction of TI information in TI data books or data sheets is permissible only if reproduction is without alteration and is accompanied by all associated warranties, conditions, limitations, and notices. Reproduction of this information with alteration is an unfair and deceptive business practice. TI is not responsible or liable for such altered documentation. Information of third parties may be subject to additional restrictions.

Resale of TI products or services with statements different from or beyond the parameters stated by TI for that product or service voids all express and any implied warranties for the associated TI product or service and is an unfair and deceptive business practice. TI is not responsible or liable for any such statements.

TI products are not authorized for use in safety-critical applications (such as life support) where a failure of the TI product would reasonably be expected to cause severe personal injury or death, unless officers of the parties have executed an agreement specifically governing such use. Buyers represent that they have all necessary expertise in the safety and regulatory ramifications of their applications, and acknowledge and agree that they are solely responsible for all legal, regulatory and safety-related requirements concerning their products and any use of TI products in such safety-critical applications, notwithstanding any applications-related information or support that may be provided by TI. Further, Buyers must fully indemnify TI and its representatives against any damages arising out of the use of TI products in such safety-critical applications.

TI products are neither designed nor intended for use in military/aerospace applications or environments unless the TI products are specifically designated by TI as military-grade or "enhanced plastic." Only products designated by TI as military-grade meet military specifications. Buyers acknowledge and agree that any such use of TI products which TI has not designated as military-grade is solely at the Buyer's risk, and that they are solely responsible for compliance with all legal and regulatory requirements in connection with such use.

TI products are neither designed nor intended for use in automotive applications or environments unless the specific TI products are designated by TI as compliant with ISO/TS 16949 requirements. Buyers acknowledge and agree that, if they use any non-designated products in automotive applications, TI will not be responsible for any failure to meet such requirements.

Following are URLs where you can obtain information on other Texas Instruments products and application solutions:

Products

Audio	www.ti.com/audio
Amplifiers	amplifier.ti.com
Data Converters	dataconverter.ti.com
DLP® Products	www.dlp.com
DSP	dsp.ti.com
Clocks and Timers	www.ti.com/clocks
Interface	interface.ti.com
Logic	logic.ti.com
Power Mgmt	power.ti.com
Microcontrollers	microcontroller.ti.com
RFID	www.ti-rfid.com
OMAP Mobile Processors	www.ti.com/omap
Wireless Connectivity	www.ti.com/wirelessconnectivity

Applications

Communications and Telecom	www.ti.com/communications
Computers and Peripherals	www.ti.com/computers
Consumer Electronics	www.ti.com/consumer-apps
Energy and Lighting	www.ti.com/energy
Industrial	www.ti.com/industrial
Medical	www.ti.com/medical
Security	www.ti.com/security
Space, Avionics and Defense	www.ti.com/space-avionics-defense
Transportation and Automotive	www.ti.com/automotive
Video and Imaging	www.ti.com/video

TI E2E Community Home Page

e2e.ti.com

Mailing Address: Texas Instruments, Post Office Box 655303, Dallas, Texas 75265
Copyright © 2011, Texas Instruments Incorporated