



85 Constant Voltage

SPECIFICATIONS

- 316L SS Pressure Sensor
- Small Profile
- 0 - 100mV Output
- Absolute and Gage
- Temperature Compensated

The 85CV is a small profile, media compatible, piezoresistive silicon pressure sensor packaged in a 316L stainless steel housing. The 85-constant voltage is offered in a weldable package or with a variety of threaded fittings such as 1/4 and 1/8NPT, 1/4BSP as well as custom process fittings.

This product is designed for OEM applications where compatibility with corrosive media is required. The sensing package utilizes silicon oil to transfer pressure from the 316L stainless steel diaphragm to the sensing element. A ceramic substrate is attached to the package that contains laser-trimmed resistors for temperature compensation and offset correction.

Please refer to the 85 uncompensated and compensated datasheets for more information on different features of the 85.

FEATURES

- Weldable and Threaded Process Fittings
- -40°C to +125°C Operating Temperature
- Up to $\pm 0.1\%$ Pressure Non-Linearity
- Solid State Reliability

APPLICATIONS

- Medical Instruments
- Process Control
- Fresh & Waste Water Measurements
- Partial Vacuum Gas Measurement
- Pressure Transmitters
- Tank Level Systems (RV & Industrial)

STANDARD RANGES

Range	psia	psig
0 to 5	•	•
0 to 15	•	•
0 to 30	•	•
0 to 50	•	•
0 to 100	•	•
0 to 300	•	•
0 to 500	•	•

PERFORMANCE SPECIFICATIONS

Unless otherwise specified: Supply Voltage: 10V_{DC}; Ambient Temperature: 25°C

PARAMETERS	005PSI			≥015PSI			UNITS	NOTES
	MIN	TYP	MAX	MIN	TYP	MAX		
Span	98	100	102	99	100	101	mV	
Zero Pressure Output	-2.0	0	2.0	-1.0	0	1.0	mV	1
Pressure Non-Linearity	-0.20		0.20	-0.10		0.10	%Span	2
Pressure Hysteresis	-0.10	±0.02	0.10	-0.05	±0.02	0.05	%Span	
Repeatability		±0.02			±0.02		%Span	
Input Resistance	5.5K	9.0K	12.5K	5.5K	9.0K	12.5K	Ω	
Output Resistance	4.0K		6.0K	4.0K		6.0K	Ω	
Temperature Error – Span	-1.5		1.5	-1.0		1.0	%Span	3
Temperature Error – Offset	-2.5		2.5	-1.0		1.0	%Span	3
Thermal Hysteresis – Span	-0.25	±0.05	0.25	-0.25	±0.05	0.25	%Span	3
Thermal Hysteresis – Offset	-0.25	±0.05	0.25	-0.25	±0.05	0.25	%Span	3
Long Term Stability – Span		±0.10			±0.10		%Span/Year	
Long Term Stability – Offset		±0.25			±0.10		%Span/Year	
Supply Voltage		10	14		10	14	V _{DC}	4
Output Load Resistance	5M			5M			Ω	5
Insulation Resistance (50V _{DC})	50M			50M			Ω	6
Output Noise (10Hz to 1KHz)		1.0			1.0		μV p-p	
Response Time (10% to 90%)			0.1			0.1	ms	
Pressure Overload			3X			3X	Rated	
Pressure Burst			4X			4X	Rated	7
Compensated Temperature	0		+50	-20		+85	°C	8
Operating Temperature	-20		+70	-40		+125	°C	8
Storage Temperature	-40		+125	-50		+125	°C	8
Media – Pressure Port	Liquids and Gases compatible with 316/316L Stainless Steel							
Media – Reference Port	Compatible with Silicon, Pyrex, Gold, Fluorosilicone Rubber, and 316/316L Stainless Steel							

Notes

1. Measured at vacuum for absolute (A), ambient for gage (G).
2. Best fit straight line.
3. Over the compensated temperature range with respect to 25°C.
4. Guarantees output/input ratiometricity.
5. Load resistance to reduce measurement errors due to output loading.
6. Between case and sensing element.
7. The maximum pressure that can be applied to a transducer without rupture of either the sensing element or transducer.
8. Maximum temperature range for product with standard cable and connector is -20 to +105°C.
9. Standard Gage units are **NOT** recommended for vacuum applications below 1/2 atmosphere, consult factory.
10. Device Marking:
Each part shall be identified with Model Number, Pressure Range, Type, Lot Number, Serial Number and Date Code
11. Shipping/Packaging
The Stainless Steel Diaphragm is protected by a plastic cap (No Fitting Options). Each unit will be packaged individually in a plastic vial with anti-static foam.
12. Direct mechanical Contact with diaphragm is prohibited. Diaphragm surface must remain free of defects (scratches, punctures, dents, fingerprints, etc) for device to operate properly. Caution is advised when handling parts with exposed diaphragms. Use protective cap whenever devices are not in use.

DIMENSIONS

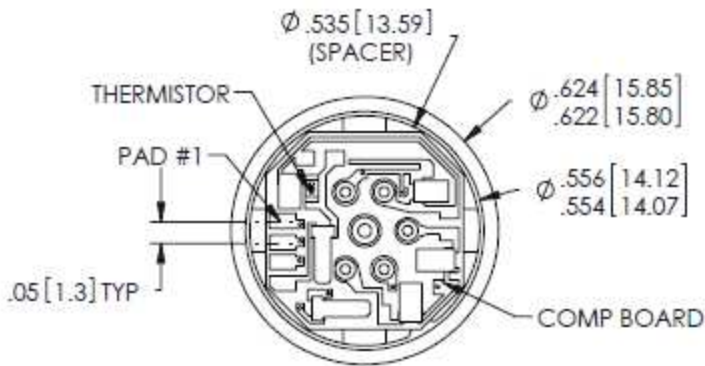
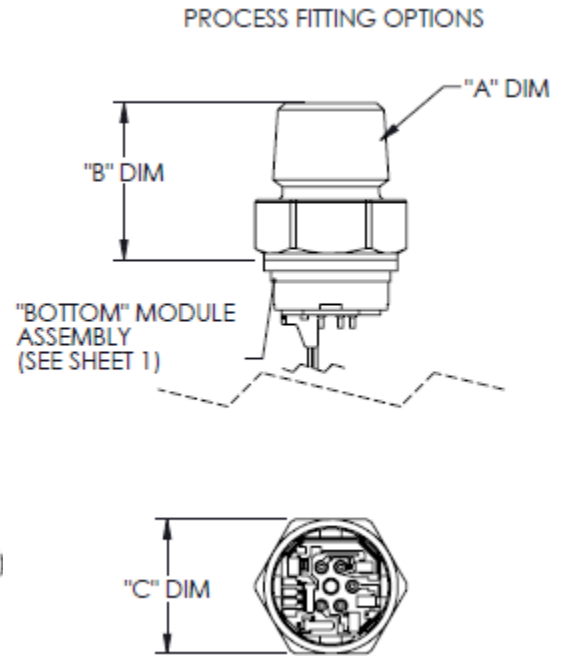
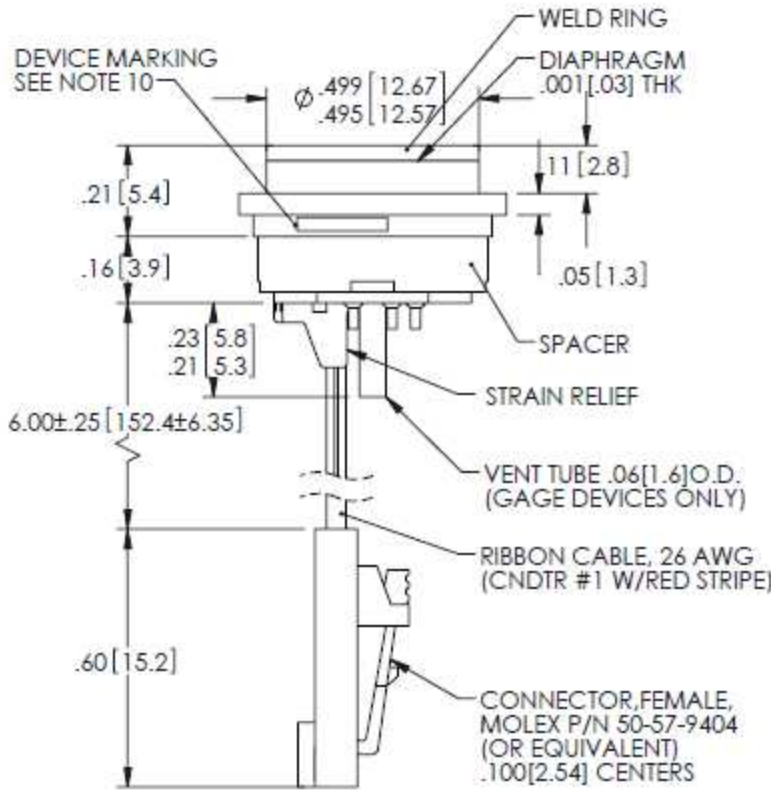

VIEW SHOWN W/O CABLE AND CONNECTOR FOR CLARITY

FITTING DIMENSIONS				
FITTING TYPE	MEAS PART NO.	"A" DIM	"B" DIM	"C" DIM
1	IC-7050	1/4-18 NPT	.99 [25.1]	7/8 [22.2] HEX
2	IC-7049	1/8-27 NPT	.96 [24.4]	7/8 [22.2] HEX
3	IC-7048	7/16-20 UNF	.81 [20.6]	7/8 [22.2] HEX
4	IC-6754	1/4-18 NPT	.73 [18.5]	5/8 [15.9] HEX
5	IC-5010	1/4-19 BSP	.76 [19.3]	3/4 [19.0] HEX
8	IC-6800	1/8-27 NPT	.60 [15.2]	5/8 [15.9] HEX
9	IC-7124	1/4-19 BSP	.94 [23.9]	7/8 [22.2] HEX

PAD NO	FUNCTION
1	-OUT
2	+OUT
3	-EX
4	+EX

RECOMMENDED MOUNTING DIMENSIONS

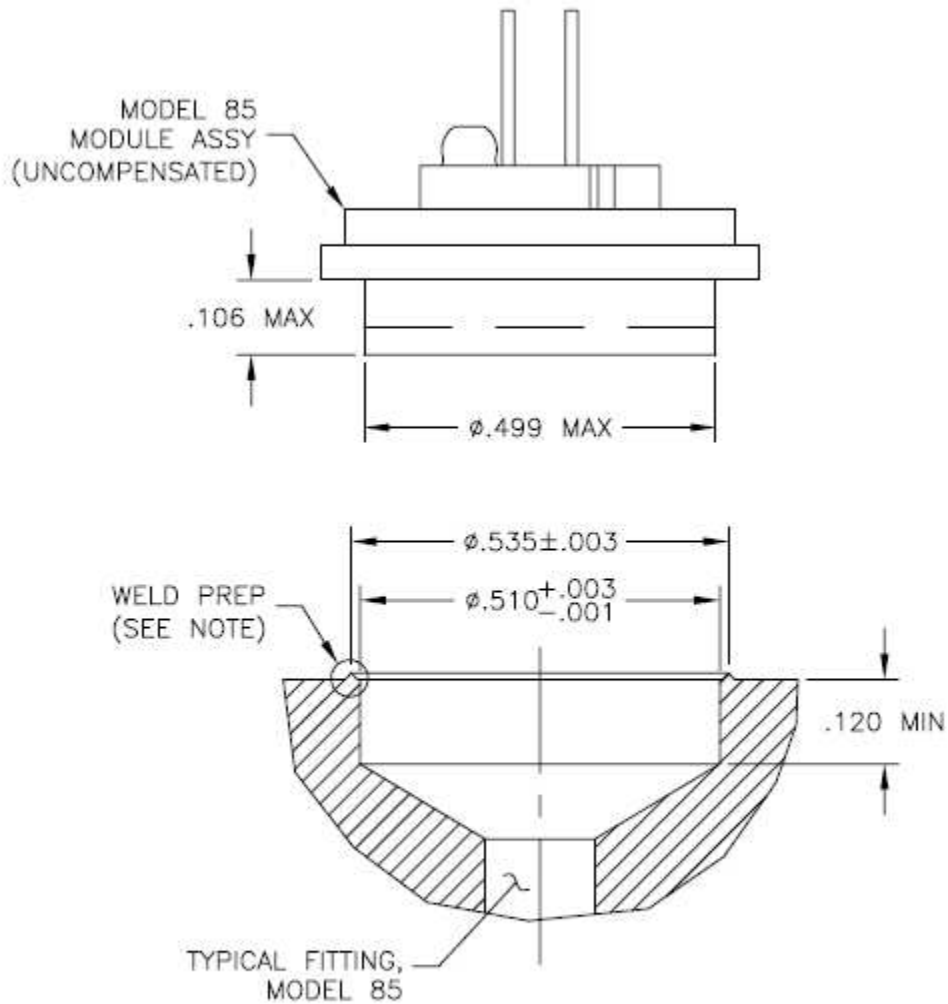

NOTE: WELD PREP SHOWN IS FOR RESISTANCE WELD. ACTUAL GEOMETRY VARIES PER CUSTOMER REQUIREMENTS.

APPLICATION SCHEMATIC

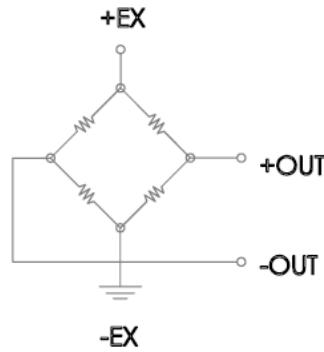

ORDERING INFORMATION

85CV - 030 A - 3 C I

Pressure Range [psi]	
005	
015	
030	
050	
100	
300	
500	

Pressure Type	
G	Gage
A	Absolute

Vent	
T	Tube
[Blank]	No Tube

Electrical	
R	Ribbon cable
C	Cable w/ Connector

Fitting Type	
Code	Port Type
1	1/4 NPT, 7/8 HEX
2	1/8 NPT, 7/8 HEX
3	7/16 UNF, 7/8 HEX
4	1/4 NPT, 3/4 HEX
5	1/4 NPT, 3/4 HEX
8	1/8 NPT, 5/8 Hex
9	1/4 BSP, 7/8 HEX

For Weldable Fitting, use '0'

NORTH AMERICA

Measurement Specialties, Inc.,
a TE Connectivity Company
Tel: +1 800-522-6752
Email: customercare.frm1@te.com

EUROPE

Measurement Specialties (Europe), Ltd.,
a TE Connectivity Company
Tel: +31 73 624 6999
Email: customercare.lcsb@te.com

ASIA

Measurement Specialties (China), Ltd.,
a TE Connectivity Company
Tel: +86 0400-820-6015
Email: customercare.shzn@te.com

TE.com/sensorsolutions

Measurement Specialties, Inc., a TE Connectivity company.

Measurement Specialties, TE Connectivity, TE Connectivity (logo) and EVERY CONNECTION COUNTS are trademarks. All other logos, products and/or company names referred to herein might be trademarks of their respective owners.

The information given herein, including drawings, illustrations and schematics which are intended for illustration purposes only, is believed to be reliable. However, TE Connectivity makes no warranties as to its accuracy or completeness and disclaims any liability in connection with its use. TE Connectivity's obligations shall only be as set forth in TE Connectivity's Standard Terms and Conditions of Sale for this product and in no case will TE Connectivity be liable for any incidental, indirect or consequential damages arising out of the sale, resale, use or misuse of the product. Users of TE Connectivity products should make their own evaluation to determine the suitability of each such product for the specific application.

© 2015 TE Connectivity Ltd. family of companies All Rights Reserved.