



85VC

Vacuum Gage, Compensated

SPECIFICATIONS

- 316L SS Pressure Sensor
- Small Profile
- 0 - 100mV Output
- Vacuum Gage
- Temperature Compensated

FEATURES

- Weldable and Threaded Process Fittings
- -40°C to +125°C Operating Temperature Range
- Up to $\pm 0.1\%$ Pressure Non-Linearity
- 1.0% Interchangeable Span (provided by gain set resistor)
- Solid State Reliability

APPLICATIONS

- Medical Instruments
- Process Control
- Fresh & Waste Water Measurements
- Partial Vacuum Gas Measurement
- Pressure Transmitters
- Tank Level Systems (RV & Industrial)

STANDARD RANGES

Range	psi
0 to 15	•
0 to 30	•
0 to 50	•
0 to 100	•
0 to 300	•
0 to 500	•

Model 85VC is a compensated, micro-machined, piezoresistive silicon pressure sensor, packaged in a 316L Stainless Steel housing designed for vacuum applications. This product is offered in a weldable package or with a variety of threaded fittings such as 1/4NPT, 1/8NPT, and 1/4BSP. Custom fittings can be manufactured upon request.

This product is designed for OEM applications where compatibility with corrosive media is required. The sensing package utilizes silicon oil to transfer pressure from the 316L Stainless Steel diaphragm to the sensing element. A ceramic substrate is attached to the package that contains laser-trimmed resistors for temperature compensation and offset correction. An additional laser trimmed resistor is included which can be used to adjust an external differential amplifier and provide span interchangeability to within $\pm 1\%$.

For additional Model 85 products designed for vacuum gage applications, datasheets for Uncompensated and Constant Voltage configurations are available.

PERFORMANCE SPECIFICATIONS

Unless otherwise specified: Supply Current: 1.5mA, Ambient Temperature: 25°C

PARAMETERS	MIN	TYP	MAX	UNITS	NOTES
Span	75	100	150	mV	1
Zero Pressure Output	-1.0	0	1.0	mV	2
Pressure Non-Linearity	-0.10		0.10	%Span	3
Pressure Hysteresis	-0.05	±0.02	0.05	%Span	
Repeatability		±0.02		%Span	
Input Resistance	2000	3500	5800	Ω	
Output Resistance	4000		6000	Ω	
Temperature Error – Span	-1.0		1.0	%Span	4
Temperature Error – Offset	-1.0		1.0	%Span	4,5
Thermal Hysteresis – Span	-0.25	±0.05	0.25	%Span	4
Thermal Hysteresis – Offset	-0.25	±0.05	0.25	%Span	4
Long Term Stability – Span		±0.10		%Span/year	
Long Term Stability – Offset		±0.10		%Span/year	
Supply Current	0.5	1.5	2.0	mA	6
Output Load Resistance	5			MΩ	7
Insulation Resistance (50Vdc)	50			MΩ	8
Output Noise (10Hz to 1KHz)		1.0		μV p-p	
Response Time (10% to 90%)			0.1	ms	
Pressure Overload			3X	Rated	9
Pressure Burst			4X	Rated	10
Compensated Temperature	-20		+85	°C	
Operating Temperature	-40		+125	°C	11
Storage Temperature	-50		+125	°C	11
Media – Pressure Port	Liquids and Gases compatible with 316/316L Stainless Steel				

Notes

- For amplified output circuits, 3.012V ±1% interchangeability with gain set resistor. See application schematic.
- Measured at Ambient Pressure.
- Best fit straight line.
- Over the compensated temperature range with respect to 25°C.
- 15psi range sensors have a Temperature Error Offset of ±1.5% (max).
- Guarantees output/input ratiometricity.
- Load resistance to reduce measurement errors due to output loading.
- Between case and sensing element.
- The maximum pressure that can be applied without changing the transducer's performance or accuracy.
- The maximum pressure that can be applied to a transducer without rupture of either the sensing element or transducer.
- Maximum temperature range for product with standard cable and connector is -20 to +105°C.
- Device Marking:
Each part shall be identified with Model Number, Pressure Range, Type, Lot Number, Serial Number and Date Code.
- Shipping/Packaging
The Stainless Steel diaphragm is protected by a static dissipative cap (no fitting option). Each unit will be packaged individually in a plastic vial with anti-static foam
- Direct mechanical contact with diaphragm is prohibited. Diaphragm surface must remain free of defects (scratches, punctures, dents, fingerprints, etc) for device to operate properly. Caution is advised when handling parts with exposed diaphragms. Use protective cap whenever devices are not in use.

DIMENSIONS

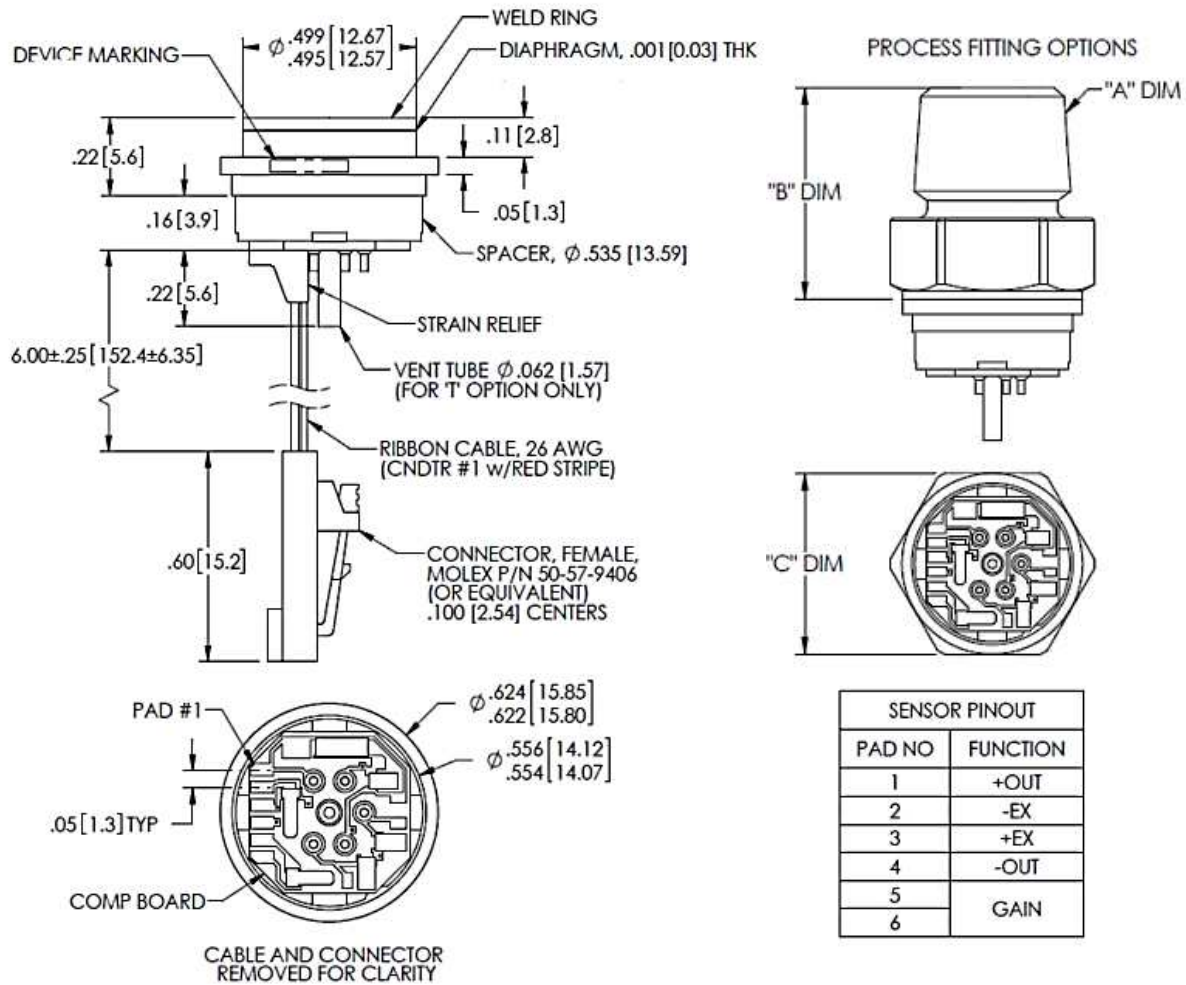

PROCESS FITTING DIMENSIONS				
FITTING TYPE	MEAS PART NO.	"A" DIM	"B" DIM	"C" DIM
1	IC-7050	1/4-18 NPT	.99[25.1]	7/8[22.2] HEX
2	IC-7049	1/8-27 NPT	.96[24.4]	7/8[22.2] HEX
3	IC-7048	7/16-20 UNF	.81[20.6]	7/8[22.2] HEX
4	IC-6754	1/4-18 NPT	.73[18.5]	5/8[15.9] HEX
5	IC-5010	1/4-19 BSP	.76[19.3]	3/4[19.0] HEX
8	IC-6800	1/8-27 NPT	.60[15.2]	5/8[15.9] HEX
9	IC-7124	1/4-19 BSP	.94[23.9]	7/8[22.2] HEX

NOTE: FITTING TYPE '4' ASSEMBLY SHOWN
ALL DIMS ARE FOR REFERENCE

RECOMMENDED MOUNTING DIMENSIONS

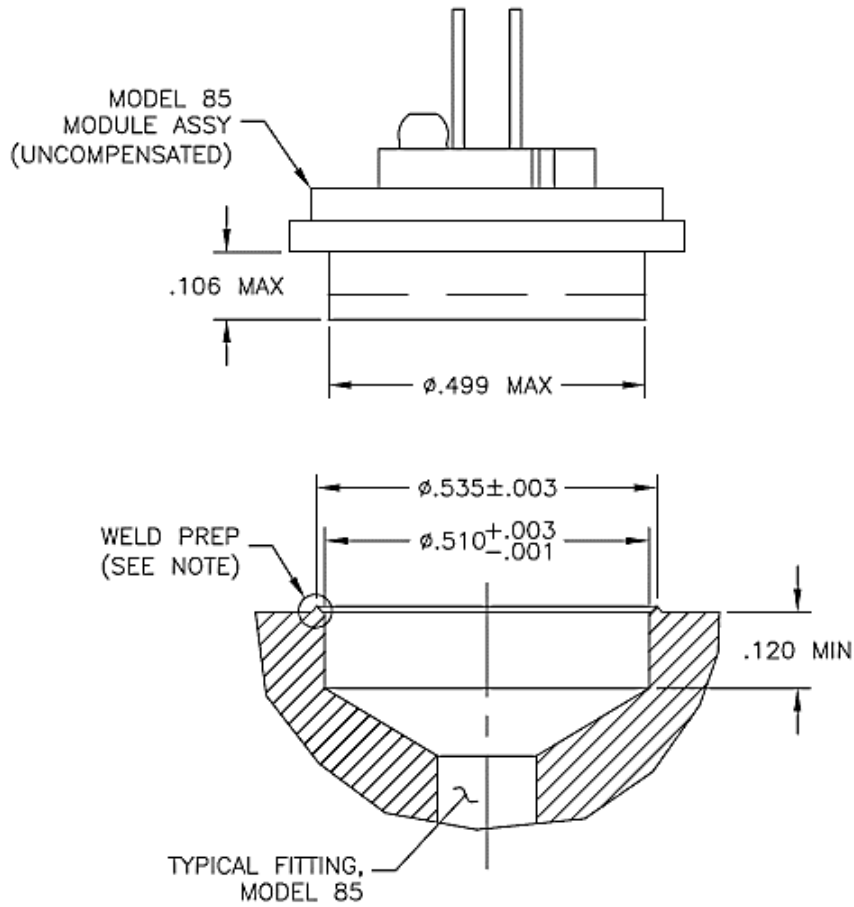

NOTE: WELD PREP SHOWN IS FOR RESISTANCE WELD. ACTUAL GEOMETRY VARIES PER CUSTOMER REQUIREMENTS.

APPLICATION SCHEMATIC

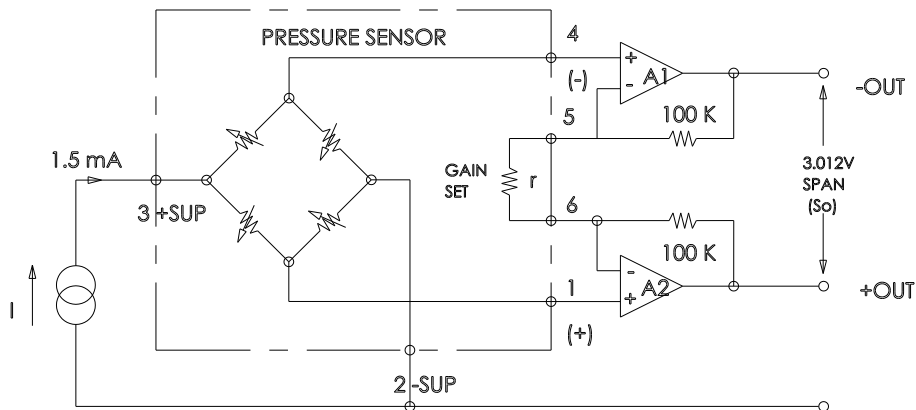

ORDERING INFORMATION

85 - 030 V - 3 R I

Pressure Range [psi]
015
030
050
100
300
500

Pressure Type
V Vacuum Gage

Vent	
T	Tube
[Blank]	No Tube

Electrical	
P	Solder Pads
R	Ribbon Cable
C	Cable w/Connector

Fitting Type	
[Blank]	Weldable (No Fitting)
1	1/4 NPT, 7/8 Hex
2	1/8 NPT, 7/8 Hex
3	7/16 UNF, 7/8 Hex
4	1/4 NPT, 5/8 Hex
5	1/4 BSP, 3/4 Hex
8	1/8 NPT, 5/8 Hex
9	1/4 BSP, 7/8 Hex

Refer to Fitting Table for more information

NORTH AMERICA

Measurement Specialties, Inc.,
a TE Connectivity Company
Tel: +1 800-522-6752
Email: customercare.frmt@te.com

EUROPE

Measurement Specialties (Europe), Ltd.,
a TE Connectivity Company
Tel: +31-73-624-6999
Email: customercare.lcsb@te.com

ASIA

Measurement Specialties (China), Ltd.,
a TE Connectivity Company
Tel: +86 0400-820-6015
Email: customercare.shzn@te.com

TE.com/sensorsolutions

Measurement Specialties, Inc., a TE Connectivity company.

Measurement Specialties, TE Connectivity, TE Connectivity (logo) and EVERY CONNECTION COUNTS are trademarks. All other logos, products and/or company names referred to herein might be trademarks of their respective owners.

The information given herein, including drawings, illustrations and schematics which are intended for illustration purposes only, is believed to be reliable. However, TE Connectivity makes no warranties as to its accuracy or completeness and disclaims any liability in connection with its use. TE Connectivity's obligations shall only be as set forth in TE Connectivity's Standard Terms and Conditions of Sale for this product and in no case will TE Connectivity be liable for any incidental, indirect or consequential damages arising out of the sale, resale, use or misuse of the product. Users of TE Connectivity products should make their own evaluation to determine the suitability of each such product for the specific application.

© 2018 TE Connectivity Ltd. family of companies All Rights Reserved.