



## 85 Compensated

### SPECIFICATIONS

- ◆ **316L SS Pressure Sensor**
- ◆ **Small Profile**
- ◆ **0 - 100mV Output**
- ◆ **Absolute and Gage**
- ◆ **Temperature Compensated**

The 85 compensated is a small profile, media compatible, piezoresistive silicon pressure sensor packaged in a 316L stainless steel housing. The 85 compensated is offered in a weldable package or with a variety of threaded fittings such as 1/4 and 1/8NPT, 1/4BSP as well as custom process fittings.

The 85 compensated is designed for OEM applications where compatibility with corrosive media is required. The sensing package utilizes silicon oil to transfer pressure from the 316L stainless steel diaphragm to the sensing element. A ceramic substrate is attached to the package that contains laser-trimmed resistors for temperature compensation and offset correction. An additional laser trimmed resistor is included which can be used to adjust an external differential amplifier and provide span interchangeability to within  $\pm 1\%$ .

Please refer to the 85 uncompensated and constant voltage datasheets for more information on different features of the 85

## FEATURES

- ◆ Weldable and Threaded Process Fittings
- ◆ -40°C to +125°C Operating Temperature Range
- ◆ Up to  $\pm 0.1\%$  Pressure Non Linearity
- ◆ 1.0% Interchangeable Span (provided by gain set resistor)
- ◆ Solid State Reliability

## APPLICATIONS

- ◆ Medical Instruments
- ◆ Process Control
- ◆ Fresh & Waste Water Measurements
- ◆ Partial Vacuum Gas Measurement
- ◆ Pressure Transmitters
- ◆ Tank Level Systems (RV & Industrial)

## STANDARD RANGES

Range	psia	psig
0 to 5	◆	◆
0 to 15	◆	◆
0 to 30	◆	◆
0 to 50	◆	◆
0 to 100	◆	◆
0 to 300	◆	◆
0 to 500	◆	◆

## PERFORMANCE SPECIFICATIONS

Supply Current: 1.5mA

Ambient Temperature: 25°C (unless otherwise specified)

PARAMETERS	005PSI			≥15PSI			UNITS	NOTES
	MIN	TYP	MAX	MIN	TYP	MAX		
Span	75	100	150	75	100	150	mV	1
Zero Pressure Output	-2.0	0	2.0	-1.0	0	1.0	mV	2
Pressure Non Linearity	-0.20		0.20	-0.10		0.10	%Span	3
Pressure Hysteresis	-0.10	±0.02	0.10	-0.05	±0.02	0.05	%Span	
Repeatability		±0.02			±0.02		%Span	
Input Resistance	2.0K	3.5K	5.8K	2.0K	3.5K	5.8K	Ω	
Output Resistance	4.0K		6.0K	4.0K		6.0K	Ω	
Temperature Error – Span	-1.0		1.0	-0.75		0.75	%Span	4
Temperature Error – Offset	-2.5		2.5	-0.50		0.50	%Span	4, 5
Thermal Hysteresis – Span	-0.25	±0.05	0.25	-0.25	±0.05	0.25	%Span	4
Thermal Hysteresis – Offset	-0.25	±0.05	0.25	-0.25	±0.05	0.25	%Span	4
Long Term Stability – Span		±0.10			±0.10		%Span/Year	
Long Term Stability – Offset		±0.25			±0.10		%Span/Year	
Supply Current	0.5	1.5	2.0	0.5	1.5	2.0	mA	6
Output Load Resistance	5M			5M			Ω	7
Insulation Resistance (50Vdc)	50M			50M			Ω	8
Output Noise (10Hz to 1KHz)		1.0			1.0		μV p-p	
Response Time (10% to 90%)			0.1			0.1	ms	
Pressure Overload			3X			3X	Rated	
Pressure Burst			4X			4X	Rated	9
Compensated Temperature	0		+50	-20		+85	°C	
Operating Temperature	-20		+70	-40		+125	°C	10
Storage Temperature	-50		+125	-50		+125	°C	10
Media – Pressure Port	Liquids and Gases compatible with 316/316L Stainless Steel							
Media – Reference Port	Compatible with Silicon, Pyrex, Gold, Fluorosilicone Rubber, and 316/316L Stainless Steel							

## Notes

- For amplified output circuits, 3.012V ±1% interchangeability with gain set resistor. See application schematic.
- Measured at vacuum for absolute (A), ambient for gage (G).
- Best fit straight line.
- Over the compensated temperature range with respect to 25°C.
- 15psi range sensors have a temperature error – offset of ±0.75% (max).
- Guarantees output/input ratiometricity.
- Load resistance to reduce measurement errors due to output loading.
- Between case and sensing element.
- The maximum pressure that can be applied to a transducer without rupture of either the sensing element or transducer.
- Maximum temperature range for product with standard cable and connector is -20 to +105°C.

## DIMENSIONS

DIMENSIONS ARE IN INCHES [mm]

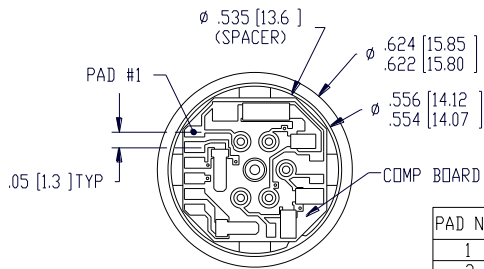
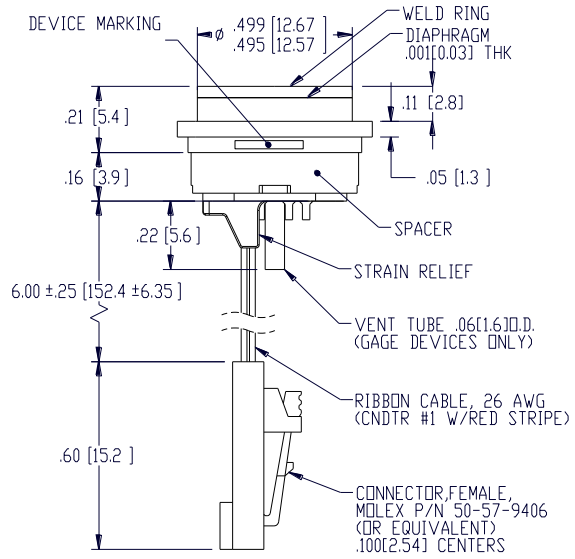

VIEW SHOWN W/D CABLE AND CONNECTOR FOR CLARITY

PAD NO	FUNCTION
1	+OUT
2	-EX
3	+EX
4	-OUT
5	
6	GAIN

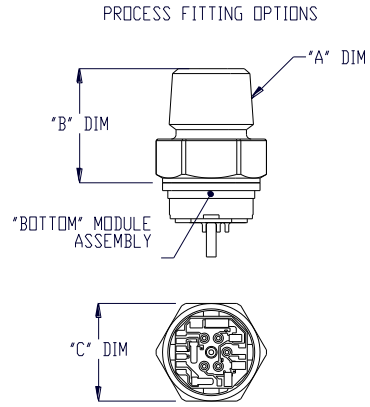

FITTING DIMENSIONS				
FITTING TYPE	MEAS PART NO.	"A" DIM	"B" DIM	"C" DIM
1	IC-7050	1/4-18 NPT	.99[25.1]	7/8[22.2] HEX
2	IC-7049	1/8-27 NPT	.96[24.4]	7/8[22.2] HEX
3	IC-7048	7/16-20 UNF	.81[20.6]	7/8[22.2] HEX
4	IC-6754	1/4-18 NPT	.73[18.5]	5/8[15.9] HEX
5	IC-5010	1/4-19 BSP	.76[19.3]	3/4[19.0] HEX
8	IC-6800	1/8-27 NPT	.60[15.2]	5/8[15.9] HEX
9	IC-7124	1/4-19 BSP	.94[23.9]	7/8[22.2] HEX

NOTE : FTG TYPE '4' ASSEMBLY SHOWN  
ALL DIMS ARE FOR REFERENCE

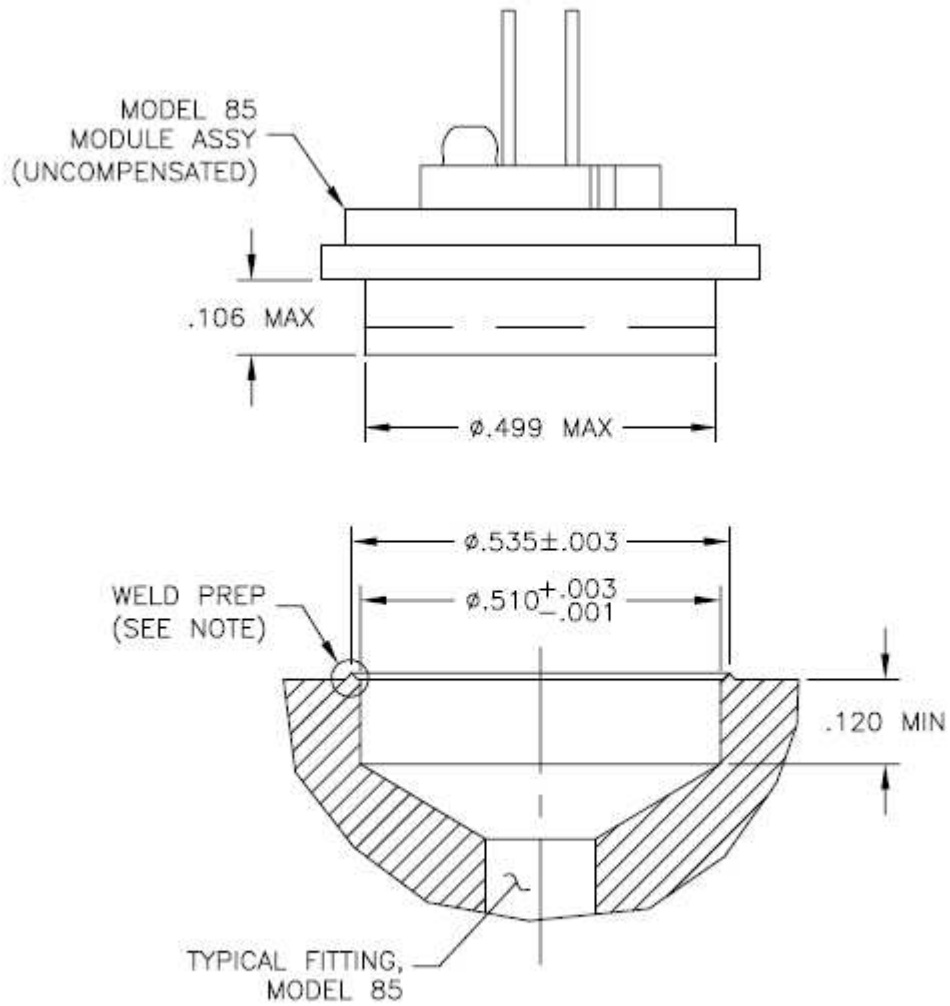

NOTE: WELD PREP SHOWN IS FOR RESISTANCE WELD. ACTUAL GEOMETRY VARIES PER CUSTOMER REQUIREMENTS.

## CONNECTIONS

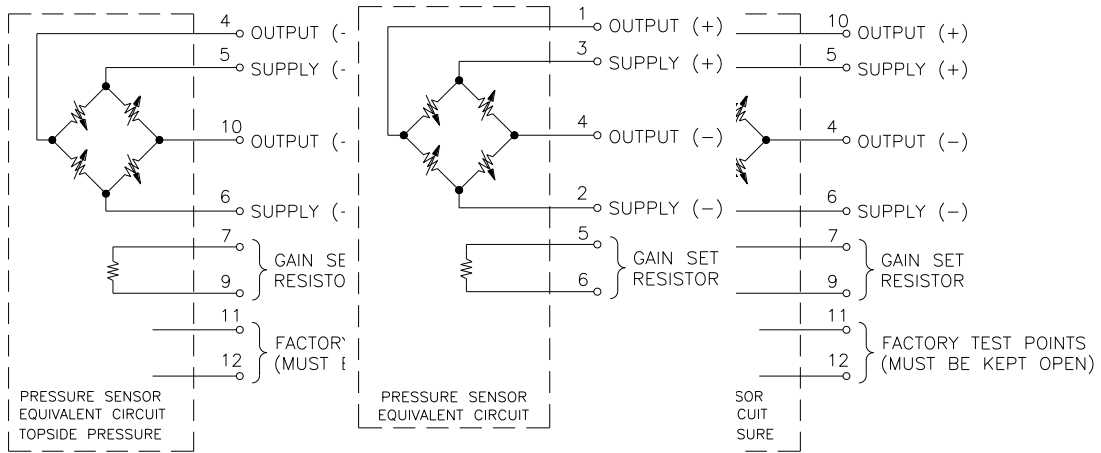

## APPLICATION SCHEMATIC

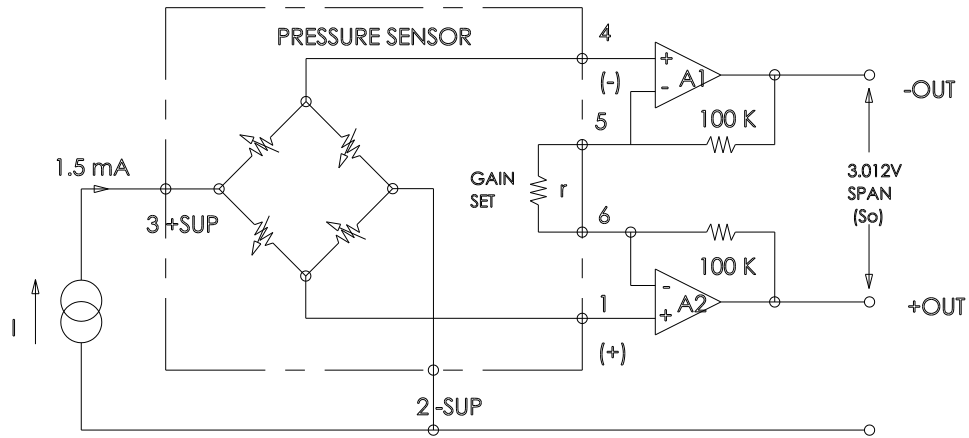

## ORDERING INFORMATION

<b>85</b>	<b>050</b>	<b>G</b>	<b>-</b>	<b>0</b>	<b>C</b>	<b>T</b>
<b>Model Name</b>						
<b>Pressure Range</b>						
005	015	030				
050	100	300				
500						
<b>Pressure Type</b>						
<b>A</b> =Absolute		<b>G</b> =Gage				
<b>Fitting Type*</b>						
See Fitting Type Table						
<b>Electrical</b>						
<b>P</b> =Solder Pads		<b>R</b> =Ribbon Cable				
<b>C</b> =Cable with Connector						
<b>Vent</b>						
<b>T</b> =Tube		<b>[Blank]</b> = No Tube				

\*Use 0 for Weldable Fitting Option

Fitting Dimensions				
Fitting Type	Meas. Part No.	"A" Dim	"B" Dim	"C" Dim
<b>1</b>	IC-7050	1/4-18NPT	.99 [25.1]	7/8 [22.2] HEX
<b>2</b>	IC-7049	1/8-27 NPT	.96 [24.4]	7/8 [22.2] HEX
<b>3</b>	IC-7048	7/16-20 UNF	.81 [20.6]	7/8 [22.2] HEX
<b>4</b>	IC-6754	1/4-18 NPT	.73 [18.5]	5/8 [15.9] HEX
<b>5</b>	IC-5010	1/4-19 BSP	.76 [19.3]	3/4 [19.0] HEX
<b>8</b>	IC-6800	1/8-27 NPT	.60 [15.2]	5/8 [15.9] HEX
<b>9</b>	IC-7124	1/4-19 BSP	.94 [23.9]	7/8 [22.2] HEX

**NORTH AMERICA**

Measurement Specialties, Inc.,  
a TE Connectivity Company  
Tel: 800-522-6752  
Email: [customercare.frm@te.com](mailto:customercare.frm@te.com)

**EUROPE**

Measurement Specialties (Europe), Ltd.,  
a TE Connectivity Company  
Tel: 800-440-5100  
Email: [customercare.lcsb@te.com](mailto:customercare.lcsb@te.com)

**ASIA**

Measurement Specialties (China), Ltd.,  
a TE Connectivity Company  
Tel: 0400-820-6015  
Email: [customercare.shzn@te.com](mailto:customercare.shzn@te.com)

**TE.com/sensorsolutions**

Measurement Specialties, Inc., a TE Connectivity company.

Measurement Specialties, TE Connectivity, TE Connectivity (logo) and EVERY CONNECTION COUNTS are trademarks. All other logos, products and/or company names referred to herein might be trademarks of their respective owners.

The information given herein, including drawings, illustrations and schematics which are intended for illustration purposes only, is believed to be reliable. However, TE Connectivity makes no warranties as to its accuracy or completeness and disclaims any liability in connection with its use. TE Connectivity's obligations shall only be as set forth in TE Connectivity's Standard Terms and Conditions of Sale for this product and in no case will TE Connectivity be liable for any incidental, indirect or consequential damages arising out of the sale, resale, use or misuse of the product. Users of TE Connectivity products should make their own evaluation to determine the suitability of each such product for the specific application.

© 2015 TE Connectivity Ltd. family of companies All Rights Reserved.