



Professionally approved products.

Product Datasheet

High Pressure Fitting

EN

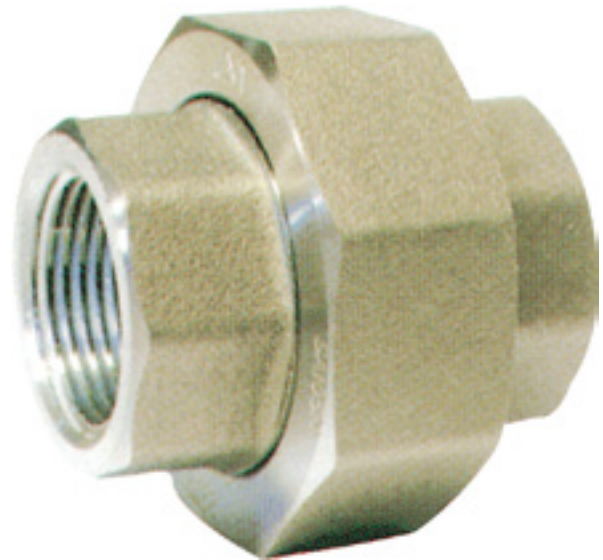

CE



Threaded Union FF

MSS SP-83

H-Threads
Minimum 4 Full Threads
Engagement Class 2A/2B Fit
ANSI B1.1

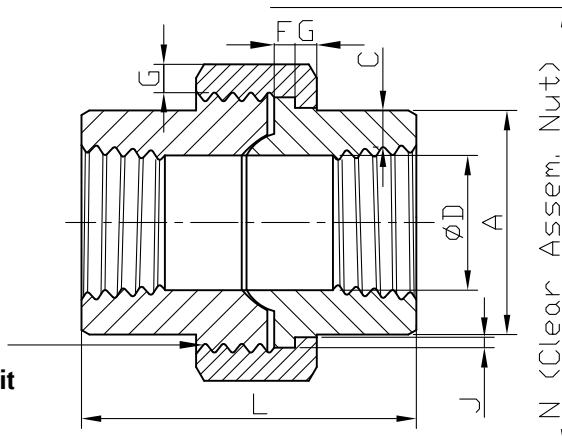

3000 LB																			
RS Code	Size		A (Min)		C(Min)		D		F(Min)		G(Min)		H	J(Min)		L		N	
	DN	NPS	mm	in	mm	in	mm	in	mm	in	mm	in	Threads Per 25.4mm	mm	in	mm	in	mm	in
826-7100	8	1/4"	19	0.75	3.02	0.12	11.13 9.45	0.44 0.37	3.18	0.13	3.18	0.13	16	1.24	0.05	41.4	1.63	50.8	2
826-7103	10	3/8"	22.9	0.9	3.2	0.13	14.27 13.51	0.56 0.53	3.43	0.14	3.43	0.14	14	1.37	0.05	46	1.81	55.9	2.2
826-7107	15	1/2"	27.7	1.09	3.73	0.15	17.86 17.07	0.7 0.67	3.68	0.14	3.68	0.14	14	1.5	0.06	49	1.93	58.4	2.3
826-7116	20	3/4"	33.5	1.32	3.91	0.15	23.01 21.39	0.91 0.84	4.06	0.16	4.06	0.16	11	1.68	0.07	56.9	2.24	66	2.6
826-7119	25	1"	41.4	1.63	4.55	0.18	28.98 27.74	1.14 1.09	4.57	0.18	4.45	0.18	11	1.85	0.07	62	2.44	78.7	3.1
826-7113	32	1-1/4"	50.5	1.99	4.85	0.19	37.69 35.36	1.48 1.39	5.33	0.21	5.21	0.21	10	2.13	0.08	71.1	2.8	94	3.7
826-7122	40	1-1/2"	57.2	2.25	5.08	0.2	43.54 41.2	1.71 1.62	5.84	0.23	5.59	0.22	10	2.31	0.09	76.5	3.01	111.8	4.4
826-7125	50	2"	70.1	2.76	5.54	0.22	55.58 52.12	2.19 2.05	6.6	0.26	6.35	0.25	10	2.69	0.11	86.1	3.39	132.1	5.2