

Distributed by:

**JAMECO**<sup>®</sup>  
ELECTRONICS

**www.Jameco.com ♦ 1-800-831-4242**

The content and copyrights of the attached  
material are the property of its owner.

Jameco Part Number 2053026

# 3M™ 4-Wall, Tripolarized Header

.050" × .100" Latch/Ejector, PTH & SMT Straight, PTH Right Angle

810 Series



- Tripolarization to mating socket
- 50 mil × 100 mil halves the connector length
- Latch and eject for rugged high performance applications
- Available for thru hole or surface mount attachment
- High temperature plastic
- Four-wall shroud provides contact protection
- Contacts: 20, 26, 36, 40, 50, 60, 68, 80 and 100
- See Regulatory Information Appendix (RIA) for chemical compliance information

Date Modified: March 26, 2007

TS-0253-30  
Sheet 1 of 7

## Physical

### Insulation

Material: High Temperature Plastic (LCP)  
Flammability: UL 94V-0  
Color: Black (RB Plating only) or Natural

### Contact

Material: Copper Alloy

### Plating

Underplating: 100 μ" [ 2.54 μm ] Nickel  
Wiping Area: 30 μ" [ 0.76 μm ] Gold  
Solder Tails: See Ordering Information  
Terminal Finish Indicator: e3 (ref JESD97)  
**Marking:** 3M Logo, Part Number and Orientation Triangle

## Electrical

**Current Rating:** 0.5 A  
**Insulation Resistance:**  $> 1 \times 10^9 \Omega$  at 500 V<sub>DC</sub>  
**Withstanding Voltage:** 500 V<sub>RMS</sub> at Sea Level

## Environmental

**Temperature Rating:** -55°C to +105°C  
**Process Rating:** Maximum 260°C (per J-STD-020C)  
**Moisture Sensitivity Level:** 1 (Profile per J-STD-020C)

UL File No.: E68080

# 3M™ 4-Wall, Tripolarized Header

.050" × .100" Latch/Ejector, PTH & SMT Straight, PTH Right Angle

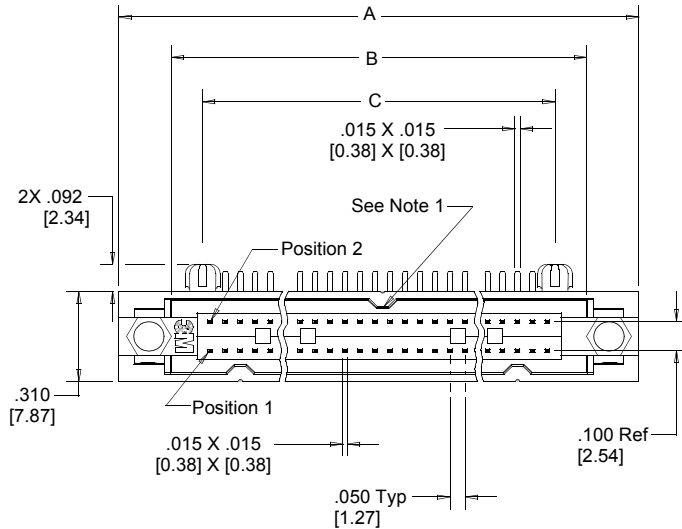
810 Series



Inch  
[mm]

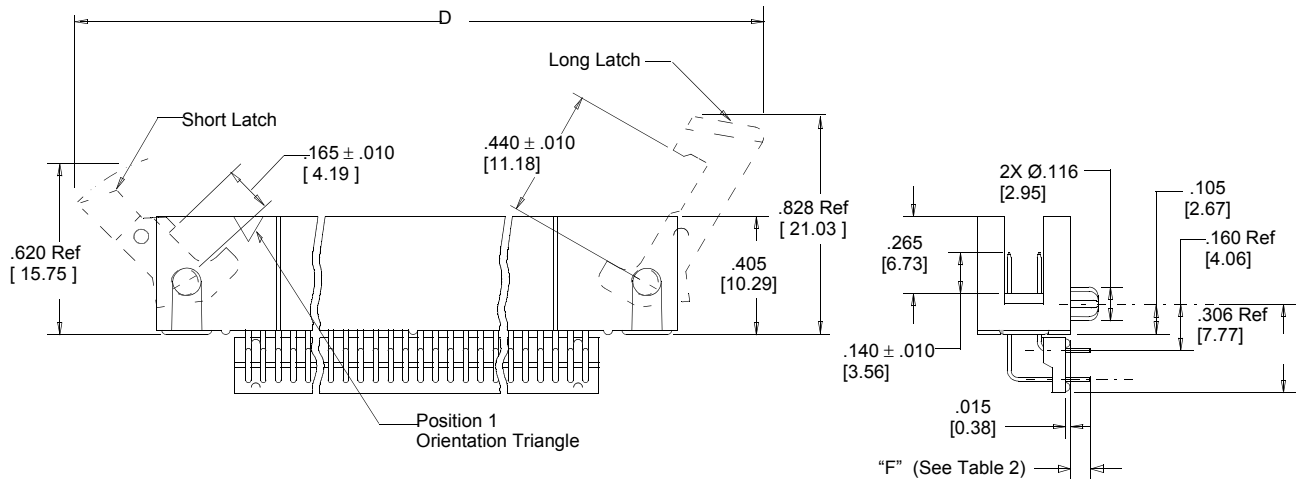
Tolerance Unless Noted			
	.0	.00	.000
inch	±.1	±.01	±.005

[ ] Dimensions for Reference Only



Contact Quantity	Dimensions				
	A	B	C	D Short (Ref.)	D Long (Ref.)
020	1.060 [26.92]	0.722 [18.34]	0.500 [12.70]	1.671 [42.44]	1.842 [46.79]
026	1.210 [30.73]	0.872 [22.15]	0.650 [16.51]	1.821 [46.25]	1.992 [50.60]
036	1.460 [37.08]	1.122 [28.50]	0.900 [22.86]	2.071 [52.60]	2.242 [56.95]
040	1.560 [39.62]	1.222 [31.04]	1.000 [25.40]	2.171 [55.14]	2.342 [59.49]
050	1.810 [45.97]	1.472 [37.39]	1.250 [31.75]	2.421 [61.49]	2.592 [65.84]
060	2.060 [52.32]	1.722 [43.74]	1.500 [38.10]	2.671 [67.84]	2.842 [72.19]
068	2.260 [57.40]	1.922 [48.82]	1.700 [43.18]	2.871 [72.92]	3.042 [77.27]
080	2.560 [65.02]	2.222 [56.44]	2.000 [50.80]	3.171 [80.54]	3.342 [84.89]
100	3.060 [77.72]	2.722 [69.14]	2.500 [63.50]	3.671 [93.24]	3.842 [97.59]

PCB Thickness	"F" Solder Tail Length ±.010
.062 [15.7]	.090 [2.29]
.094 [2.39]	.112 [2.84]
.125 [3.18]	.143 [3.63]



Notes:

1. This polarization bump does not exist on the 20 position header.
2. Recommended to be mated to the .050" X .100" Wiremount Socket 820 Series.

## Ordering Information

PTH Right Angle Header

81XXX-5X0X03-XX

Contact Quantity  
(See Table 1)

Ejector/Latch System:

- 0 = None
- 5 = With Short Ejectors Installed
- 6 = With Long Ejector Latches Installed

Contact Tail:

- 2 = Solder Tail for .062 [ 1.57 ] PC Board
- 3 = Solder Tail for .094 [ 2.39 ] PC Board
- 4 = Solder Tail for .125 [ .318 ] PC Board

Plating suffix:

- blank = tin lead tails (RIA E3 & C2 apply)
- RB = matte tin tails (RIA E1 & C1 apply)

## Ejector Latch

- Long
- 3505-28 (natural)
- 3505-28B (black)
- Short
- 3505-29 (natural)
- 3505-29B (black)

TS-0253-30

Sheet 2 of 7



Interconnect Solutions

<http://www.3M.com/interconnects/>

3M is a trademark of 3M Company.

For technical, sales or ordering information call

800-225-5373

# 3M™ 4-Wall, Tripolarized Header

.050" × .100" Latch/Ejector, PTH & SMT Straight, PTH Right Angle

810 Series

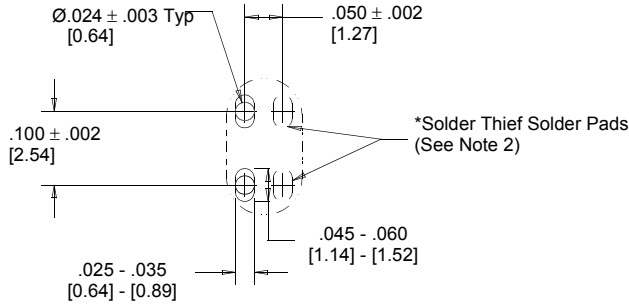
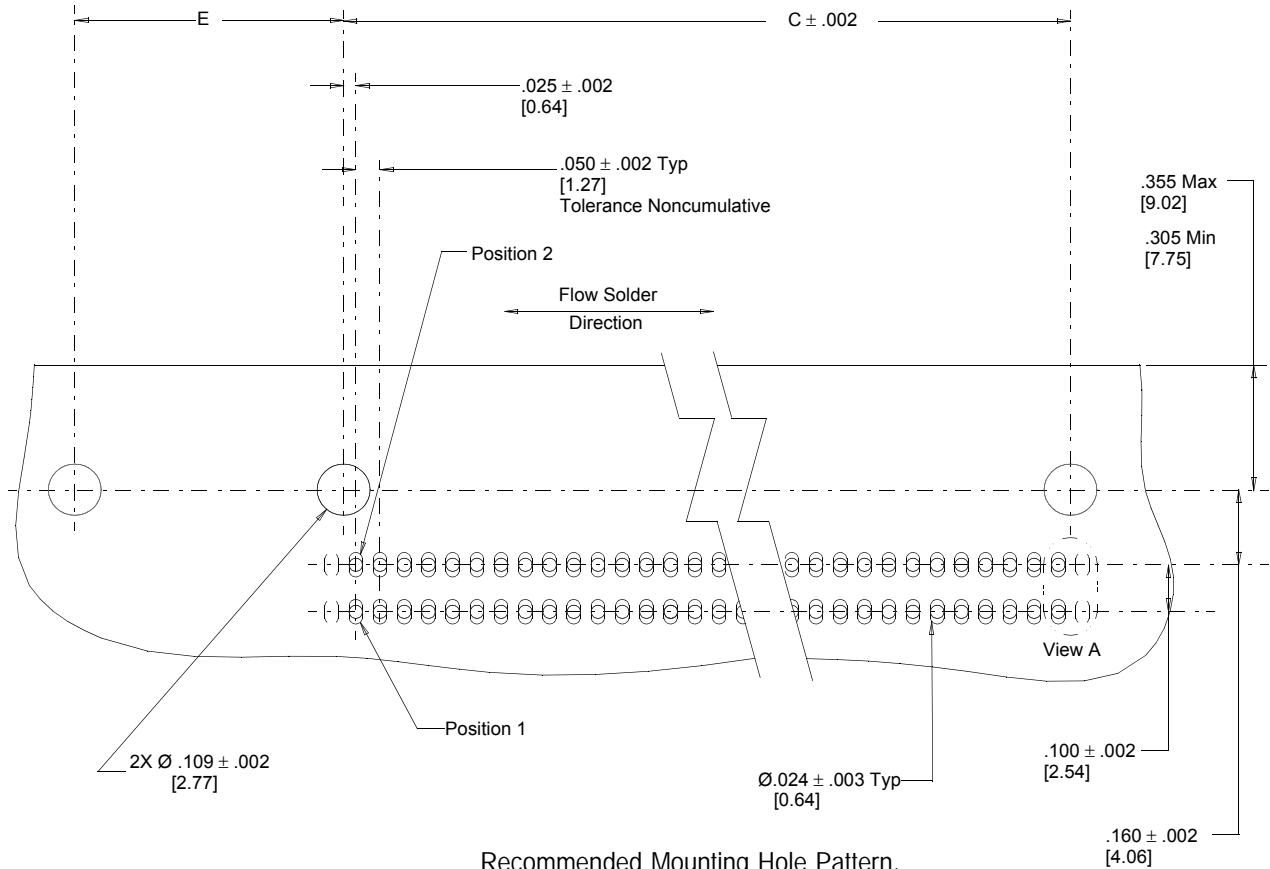


Table 3	
Ejector Latches	Dimension E Min
None	.575 [14.61]
Long	1.010 [25.65]
Short	.885 [22.48]

\*Solder Thief Solder Pads required only on Solder side of PC Board.

View A



Recommended Mounting Hole Pattern,  
PTH Right Angle Header

(Shown for mounting side of PC Board)

**Notes:**

1. Recommended to process PC Boards through the solder bath such that the connector enters end first (two solder tails at a time). This will help prevent solder bridging.
2. A Dummy or Solder Thief Solder Pad at the end of each row is recommended on the bottom or solder side of the PC Board in order to help prevent solder bridging on the end solder tails. The solder thieves are only required on the end of the rows which leave the solder bath last.
3. In order to facilitate soldering it is recommended that ejector latches be installed after the soldering process.

TS-0253-30  
Sheet 3 of 7

# 3M™ 4-Wall, Tripolarized Header

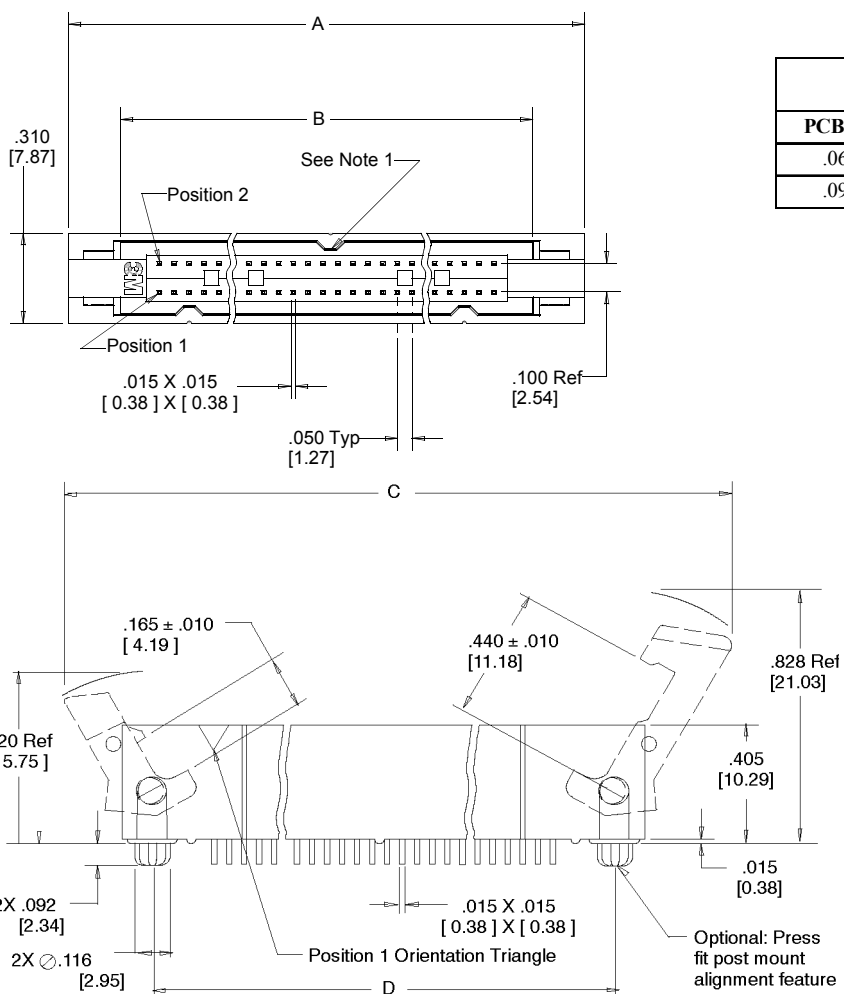
.050" × .100" Latch/Ejector, PTH & SMT Straight, PTH Right Angle

810 Series

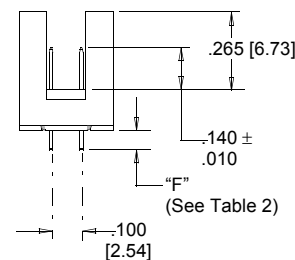


**Table 4**

Contact Quantity	Dimensions									
	A		B		C Short (Ref.)		C Long (Ref.)		D	
020	1.060	[26.92]	0.722	[18.34]	1.671	[42.44]	1.842	[46.79]	0.860	[21.84]
026	1.210	[30.73]	0.872	[22.15]	1.821	[46.25]	1.992	[50.60]	1.010	[25.65]
036	1.460	[37.08]	1.122	[28.50]	2.071	[52.60]	2.242	[56.95]	1.260	[32.00]
040	1.560	[39.62]	1.222	[31.04]	2.171	[55.14]	2.342	[59.49]	1.360	[34.54]
050	1.810	[45.97]	1.472	[37.39]	2.421	[61.49]	2.592	[65.84]	1.610	[40.89]
060	2.060	[52.32]	1.722	[43.74]	2.671	[67.84]	2.842	[72.19]	1.860	[47.24]
080	2.560	[65.02]	2.222	[56.44]	3.171	[80.54]	3.342	[84.89]	2.360	[59.94]
100	3.060	[77.72]	2.722	[69.14]	3.671	[93.24]	3.842	[97.59]	2.860	[72.64]



PCB Thickness	"F" Solder Tail Length ± .010
.062 [15.7]	.090 [2.29]
.094 [2.39]	.112 [2.84]



- Notes:
1. This polarization bump does not exist on the 20 position header.
  2. Recommended to be mated to the .050" x .100" 820 Series Socket.

## Ordering Information PTH Straight Header

**81XXX-6X0X0X-XX**

Contact Quantity  
(See Table 4)

Ejector/Latch System:

- 0 = None
- 5 = With Short Ejectors Installed
- 6 = With Long Ejector latches Installed

Board Mounting Options:

- 1 = None
- 3 = Press fit posts both ends

Contact Tail: (See Table 2)

- 2 = Solder Tail for .062 [ 1.57 ] PC Board
- 3 = Solder Tail for .094 [ 2.39 ] PC Board
- 4 = Solder Tail for .125 [ .318 ] PC Board

Plating suffix:

- blank = tin lead tails (RIA E3 & C2 apply)
- RB = matte tin tails (RIA E1 & C1 apply)

## Ejector Latch

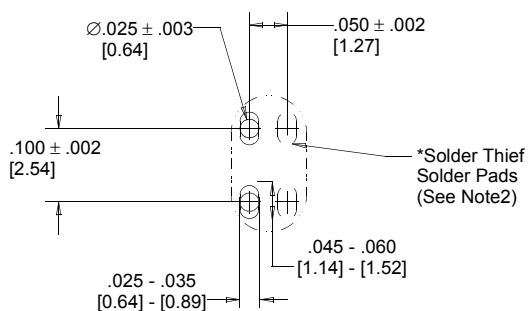
- Long
- 3505-28 (natural)
- 3505-28B (black)
- Short
- 3505-29 (natural)
- 3505-29B (black)

TS-0253-30  
Sheet 4 of 7

# 3M™ 4-Wall, Tripolarized Header

.050" × .100" Latch/Ejector, PTH & SMT Straight, PTH Right Angle

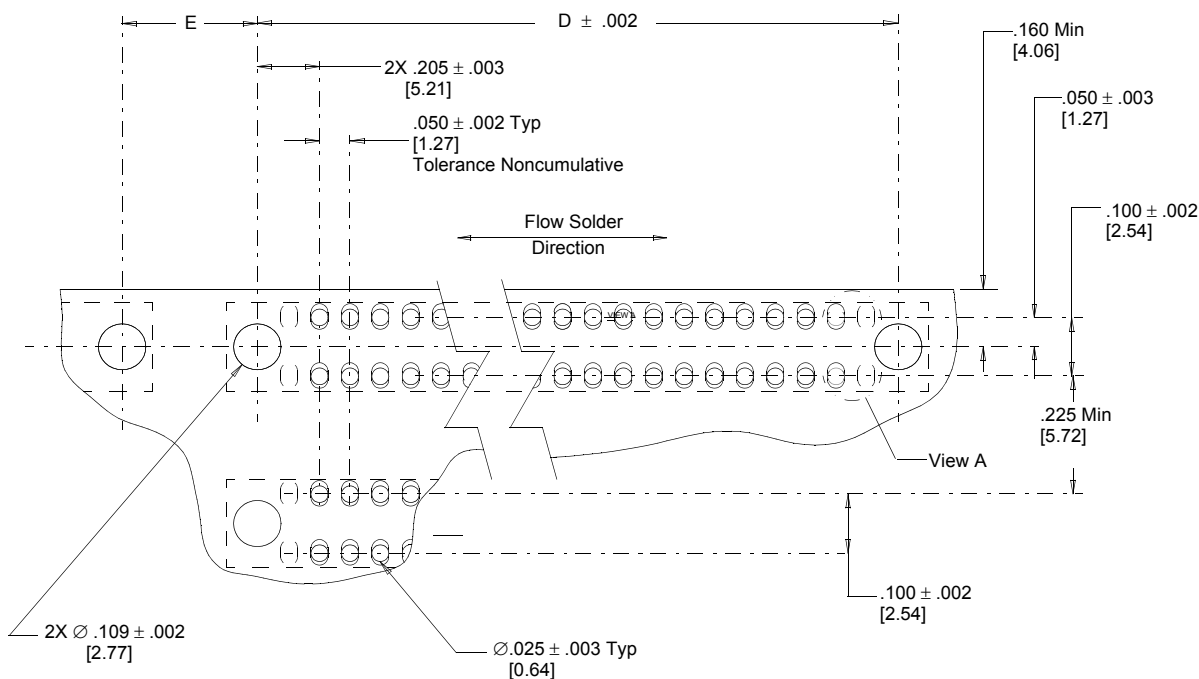
810 Series



\*Solder Thief Solder Pads required only on Solder side of PC Board.

View A

Table 6	
Ejector/Latches	Dimension E (Min)
None	.215 [ 5.46 ]
Long	.650 [16.51]
Short	.525 [13.34]



Recommended Mounting Hole Pattern.  
PTH Vertical Header

(Shown for mounting side of PC Board)

Inch  
[mm]

Tolerance Unless Noted			
	.0	.00	.000
inch	±.1	±.01	±.005

[ ] Dimensions for Reference Only

Note:

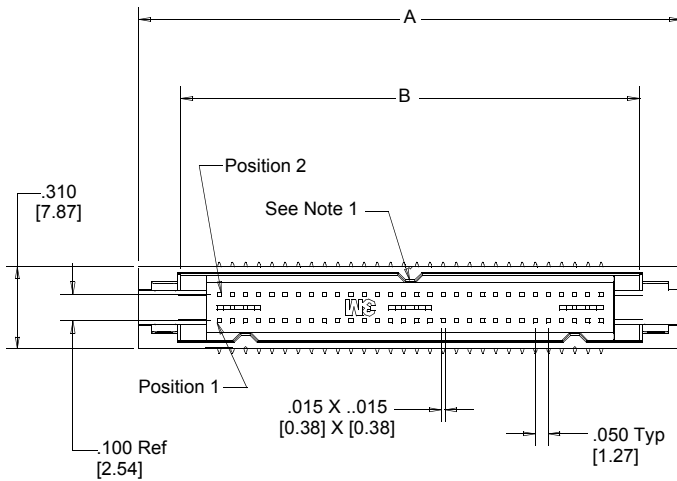
1. Recommended to process PC Boards through the solder bath such that the connector enters end first (two solder tails at a time). This will help prevent solder bridging.
2. A Solder Thief Solder Pad (Dummy Pad) at the end of each row is recommended on the bottom or solder side of the PC Board in order to help prevent solder bridging on the end solder tails. The Solder Thiefs are only required on the end of the rows which leave the solder bath last.
3. In order to facilitate soldering it is recommended that ejector latches be installed after the soldering process.

TS-0253-30  
Sheet 5 of 7

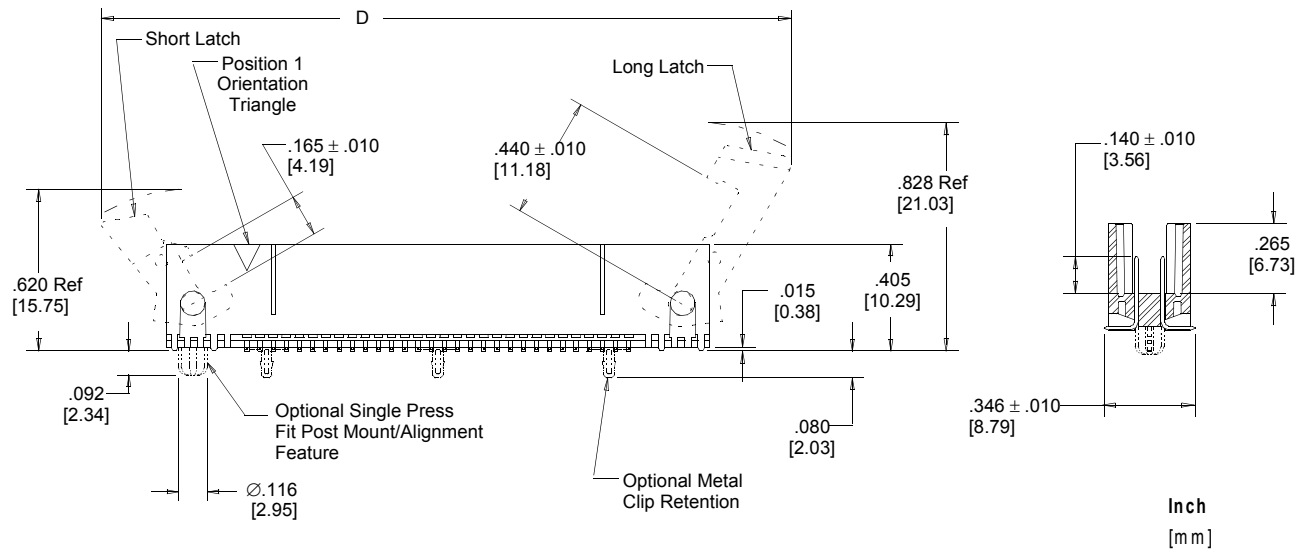
# 3M™ 4-Wall, Tripolarized Header

.050" × .100" Latch/Ejector, PTH & SMT Straight, PTH Right Angle

810 Series



Contact Quantity	Dimensions				Tape & Reel Suffix
	A	B	D Short (Ref.)	D Long (Ref.)	
020	1.060 [26.92]	0.722 [18.34]	1.671 [42.44]	1.842 [46.79]	WD
026	1.210 [30.73]	0.872 [22.15]	1.821 [46.25]	1.992 [50.60]	WE
036	1.460 [37.08]	1.122 [28.50]	2.071 [52.60]	2.242 [56.95]	
040	1.560 [39.62]	1.222 [31.04]	2.171 [55.14]	2.342 [59.49]	
050	1.810 [45.97]	1.472 [37.39]	2.421 [61.49]	2.592 [65.84]	WF
060	2.060 [52.32]	1.722 [43.74]	2.671 [67.84]	2.842 [72.19]	
068	2.260 [57.40]	1.922 [48.82]	2.871 [72.92]	3.042 [77.27]	WG
080	2.560 [65.02]	2.222 [56.44]	3.171 [80.54]	3.342 [84.89]	
100	3.060 [77.72]	2.722 [69.14]	3.671 [93.24]	3.842 [97.59]	WH



Inch  
[mm]

Tolerance Unless Noted			
	.0	.00	.000
inch	±.1	±.01	±.005

[ ] Dimensions for Reference Only

Notes:

1. This polarization bump does not exist on the 20 position header.
2. Recommended to be mated to the .050" X .100" 820 Series Wiremount Socket.

## Ordering Information

### SMT Straight Header

81XXX-6X0C0X-XX-XX

Contact Quantity (See Table 7)

Ejector/Latch System:  
 0 = None  
 5 = With Short Ejectors Installed  
 6 = With Long Ejector Latches Installed

Board Mounting Options:  
 1 = None  
 4 = Press Fit Post Mount at Position 1 end  
 7 = Metal retention clips  
 8 = #1 end press fit post & metal retention clips

Packaging Options:  
 Blank = Trays  
 WX = Tape & Reel Package (see table)

Plating suffix:  
 blank = tin lead tails (RIA E3 & C2 apply)  
 RB = matte tin tails (RIA E1 & C1 apply)

### Ejector Latch

Long  
 3505-28 (natural)  
 3505-28B (black)  
 Short  
 3505-29 (natural)  
 3505-29B (black)

TS-0253-30  
 Sheet 6 of 7

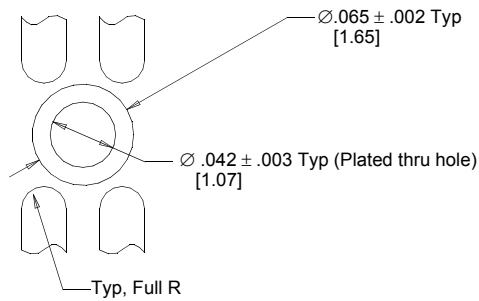
# 3M™ 4-Wall, Tripolarized Header

.050" × .100" Latch/Ejector, PTH & SMT Straight, PTH Right Angle

810 Series

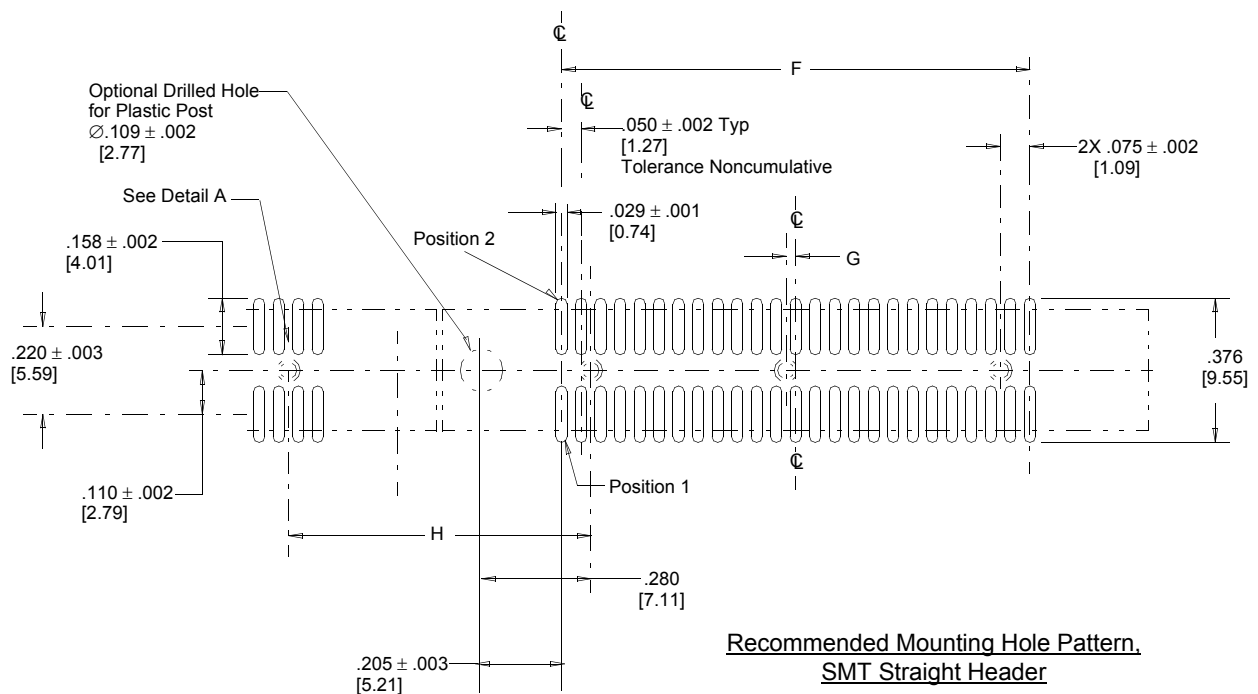
Ejector Latches	Dimensions
	H Min
No	.775 [19.69]
Short	1.085 [27.56]
Long	1.21 [30.73]

No. of Positions	Dimensions	
	F	G
20	.450 [11.43]	N/A
26	.600 [15.24]	.025 [0.64]
36	.850 [21.59]	N/A
40	.950 [24.13]	N/A
50	1.200 [30.48]	.025 [.64]
60	1.450 [36.83]	0.000
68	1.650 [41.91]	0.000
80	1.950 [49.53]	0.000
100	2.450 [62.23]	0.000



### Detail A

Optional plated thru hole for metal clip retention



### Recommended Mounting Hole Pattern, SMT Straight Header

(Shown for mounting side of PC Board)

Note: In order to facilitate soldering it is recommended that ejector latches be installed after the soldering process.

TS-0253-30  
Sheet 7 of 7

## Regulatory Information Appendix

### 3M Electronic Solutions Division/Interconnect

#### EUROPE

##### **Appendix E1: European Union RoHS**

Directive 2002/95/EC, Restriction of the Use of Certain Hazardous Substances in Electrical & Electronic Equipment, as amended by EU Commission Decision 2005/618/EC.

**This product is RoHS Compliant 2005/95/EC.**

“RoHS Compliant 2005/95/EC” means that the product or part (“Product”) does not contain any of the substances in excess of the maximum concentration values in EU Directive 2002/95/EC, as amended by Commission Decision 2005/618/EC, unless the substance is in an application that is exempt under EU RoHS. Unless otherwise stated by 3M in writing, this information represents 3M’s best knowledge and belief based upon information provided by third party suppliers to 3M.

In the event any product is proven not to conform with 3M’s Regulatory Information Appendix, then 3M’s entire liability and Buyer’s exclusive remedy will be in accordance with the Warranty stated below.

##### **Appendix E2: European Union RoHS**

Directive 2002/95/EC, Restriction of the Use of Certain Hazardous Substances in Electrical & Electronic Equipment, as amended by EU Commission Decision 2005/618/EC.

**This product contains lead in the compliant pin area in excess of the maximum concentration value allowed but is compliant by exemption under EU Commission Decision 2005/747/EC.**

“RoHS Compliant 2005/95/EC” means that the product or part (“Product”) does not contain any of the substances in excess of the maximum concentration values in EU Directive 2002/95/EC, as amended by Commission Decision 2005/618/EC, unless the substance is in an application that is exempt under EU RoHS. Unless otherwise stated by 3M in writing, this information represents 3M’s best knowledge and belief based upon information provided by third party suppliers to 3M.

In the event any product is proven not to conform with 3M’s Regulatory Information Appendix, then 3M’s entire liability and Buyer’s exclusive remedy will be in accordance with the Warranty stated below.

##### **Appendix E3: European Union RoHS**

Directive 2002/95/EC, Restriction of the Use of Certain Hazardous Substances in Electrical & Electronic Equipment as amended by Commission Decision 2005/618/EC.

**This product contains lead in the solder tail area in excess of the maximum concentration value allowed.**

Unless otherwise stated by 3M in writing, this information represents 3M’s best knowledge and belief based upon information provided by third party suppliers to 3M.

In the event any product is proven not to conform with 3M’s Regulatory Information Appendix, then 3M’s entire liability and Buyer’s exclusive remedy will be in accordance with the Warranty stated below.

##### **Appendix E4: European Union RoHS**

Directive 2002/95/EC, Restriction of the Use of Certain Hazardous Substances in Electrical & Electronic Equipment, as amended by EU Commission Decision 2005/618/EC.

This product contains decaBDE in the insulating material in excess of the maximum concentration value allowed but is compliant by exemption under EU Commission Decision 2005/17/EC.

“RoHS Compliant 2005/95/EC” means that the product or part (“Product”) does not contain any of the substances in excess of the maximum concentration values in EU Directive 2002/95/EC, as amended by Commission Decision 2005/618/EC, unless the substance is in an application that is exempt under EU RoHS. Unless otherwise stated by 3M in writing, this information represents 3M’s best knowledge and belief based upon information provided by third party suppliers to 3M.

In the event any product is proven not to conform with 3M’s Regulatory Information Appendix, then 3M’s entire liability and Buyer’s exclusive remedy will be in accordance with the Warranty stated below.



## Appendix C1: China RoHS

Electronic Industry Standard of the People's Republic of China, SJ/T11363-2006, Requirements for Concentration Limits for Certain Hazardous Substances in Electronic Information Products.

This symbol, per Marking for the Control of Pollution Caused by Electronic Information Products, SJ/T11364-2006, means that the product or part **does not** contain any of the following substances in excess of the following maximum concentration values in any homogeneous material: (a) 0.1% (by weight) for lead, mercury, hexavalent chromium, polybrominated biphenyls or polybrominated diphenyl ethers; or (b) 0.01% (by weight) for cadmium. Unless otherwise stated by 3M in writing, this information represents 3M's best knowledge and belief based upon information provided by third party suppliers to 3M.

In the event any product is proven not to conform with 3M's Regulatory Information Appendix, then 3M's entire liability and Buyer's exclusive remedy will be in accordance with the Warranty stated below.



## Appendix C2: China RoHS

Electronic Industry Standard of the People's Republic of China, SJ/T11363-2006, Requirements for Concentration Limits for Certain Hazardous Substances in Electronic Information Products.

This symbol, per Marking for the Control of Pollution Caused by Electronic Information Products, SJ/T11364-2006, means that the product or part **does** contain a substance, as detailed in the chart below, in excess of the following maximum concentration values in any homogeneous material: (a) 0.1% (by weight) for lead, mercury, hexavalent chromium, polybrominated biphenyls or polybrominated diphenyl ethers; or (b) 0.01% (by weight) for cadmium. Unless otherwise stated by 3M in writing, this information represents 3M's best knowledge and belief based upon information provided by third party suppliers to 3M.

The numerical reference in the symbol above should not be construed as a representation regarding the product's life or an extension of a product warranty. The product warranty is stated below. In the event any product is proven not to conform with 3M's Regulatory Information Appendix, then 3M's entire liability and Buyer's exclusive remedy will be in accordance with the product Warranty stated below.

产品中有毒有害物质或元素的名称及含量 Name and Content of Hazardous Substances or Elements

部件名称 (Part or Component Name)	有毒有害物质或元素 (Hazardous Substances or Elements)					
	铅 (Pb)	汞 (Hg)	镉 (Cd)	六价铬 (Cr(VI))	多溴联苯 (PBB)	多溴二苯醚 (PBDE)
端子镀层 (contact plating)	×	○	○	○	○	○
○: 表示该有毒有害物质在该部件所有均质材料中的含量均在SJ/T11363-2006 标准规定的限量要求以下。(Indicates that this hazardous substance contained in all of the homogeneous materials for this part is below the limit requirement in SJ/T11363-2006.) ×: 表示该有毒有害物质至少在该部件的某一均质材料中的含量超出SJ/T11363-2006 标准规定的限量要求。(Indicates that this hazardous substance contained in at least one of the homogeneous materials used for this part is above the limit requirement in SJ/T11363-2006.)						

### Important Notice

All statements, technical information, and recommendations related to 3M's products are based on information believed to be reliable, but the accuracy or completeness is not guaranteed. Before using this product, you must evaluate it and determine if it is suitable for your intended application. You assume all risks and liability associated with such use. Any statements related to the product which are not contained in 3M's current publications, or any contrary statements contained on your purchase order shall have no force or effect unless expressly agreed upon, in writing, by an authorized officer of 3M.

### Warranty; Limited Remedy; Limited Liability.

This product will be free from defects in material and manufacture for a period of ninety (90) days from the time of purchase. **3M MAKES NO OTHER WARRANTIES INCLUDING, BUT NOT LIMITED TO, ANY IMPLIED WARRANTY OF MERCHANTABILITY OR FITNESS FOR A PARTICULAR PURPOSE.** If this product is defective within the warranty period stated above, your exclusive remedy shall be, at 3M's option, to replace or repair the 3M product or refund the purchase price of the 3M product. **Except where prohibited by law, 3M will not be liable for any indirect, special, incidental or consequential loss or damage arising from this 3M product, regardless of the legal theory asserted.**



### Electronic Solutions Division

6801 River Place Blvd.  
Austin, TX 78726-9000  
800/225-5373  
www.3M.com/interconnects