

---

# LM, LE and LEB Laser Printable Polyester Labels on Sheet

## Technical Datasheet

TTDS-069 Revision 2 - April 2019

**LM, LE and LEB are metalized, white, and yellow polyester labels with a permanent acrylic adhesive and a special top coat designed specifically for use with laser printers.**

LM and LE are metalized and white Polyester labels in US sheet format (8.5 x 11.0 inches). They are ideal for bar coding, rating plates and general labelling applications, requiring high durability labels with good resistance to a variety of industrial fluids.

LEB labels are white, silver and yellow Polyester labels supplied on a European A4 sheet format (210 x 297 mm), designed for bar coding, name plates, equipment labels and general label applications. LEB's have good resistance to abrasion, oil, industrial chemicals and fluids..

# LM, LE AND LEB, LASER PRINTABLE POLYESTER LABELS

## Features

- Laser printable
- High durability and tear strength
- Designed to withstand exposure to oil, industrial chemicals and fluids.

## Temperature Rating

- Service Temperature  
-40°C to +150°C ( -40°F to +302°F)
- Min. Application Temperature: 10°C (50°F)

## Applications

- Ideal for bar coding, PCB and component labeling
- General labeling applications
- Industrial and Electrical applications

## Design for Environment

- Further information and a downloadable declaration covering RoHS and REACH compliance can be found at the TE Product Compliance Support Centre:

<http://www.te.com/usa-en/utilities/product-compliance.html>

## Specifications / Approvals

### Industry

UL MH17292 - PGJ12 certification pending

## Shelf Life

2 years when following good commercial storage practice detailed below

## Storage

Product should be stored in the original packaging, with any plastic covers which were included during shipping. Store out of direct sunlight in a clean, dry, dust free, environment. Product should not be stored outside of the designed storage temperature, which is 20 to 25 °C (68°F to 77°F), 40 to 50 % RH.



PAGE 2

**Technical Performance**

	Requirement	Results
<b>Print Permanence</b>		
Marking of Electrical Insulating Materials, SAE AS 5942	Legible after 50 rubs 1kg weight with an eraser	Pass
<b>Fluid Exposure</b>		<b>Printed legend</b>
<ul style="list-style-type: none"> <li>IPA Isopropyl Alcohol</li> <li>IRM 902</li> <li>MIL-H-83282</li> <li>Diesel Fuel</li> <li>Kilfrost DF plus</li> <li>Tap water</li> <li>5% Salt solution</li> <li>Detergent (1% Teepol)</li> <li>WD-40 lubricant</li> </ul>	TE doc 109-121012, 24 hours immersion at 23°C followed by 20 rubs with cloth, minimum print contrast 3*, legible  *Print contrast as defined in TE doc. 411-121002	Pass Pass Pass Pass Pass Pass Pass Pass Pass
<b>Adhesion to FTM1 (180°)</b>		<b>Typical Peel force (N/25mm (oz/in.))</b>
<b>Test surface:</b>	FTM1 (180°)	<b>20min Dwell      72hr Dwell</b>
<ul style="list-style-type: none"> <li>Stainless steel</li> <li>Glass</li> <li>Aluminium</li> <li>Polypropylene</li> <li>Tufnol</li> <li>Adhesive to Adhesive</li> </ul>		11 (41.6)      18 (64.3) 12 (43.3)      20 (72.8) 14 (51.5)      16 (59.4) 1 (5.0)          3 (10.2) 13 ( 47.2)      17 (63.4) 6 (22.7)        9 (33.2)

**Typical Label Thickness**

- Label (including adhesive): 0.07 mm / 0.0028 inches
- Liner: 0.166 mm / 0.0065 inches

TE Connectivity, TE Connectivity (logo) and Every Connection Counts are trademarks. All other logos, products and/or company names referred to herein might be trademarks of their respective owners.

Where possible, TE have tested product as a finished item, including the print. Operational tests are followed by an assessment of mark adherence to validate fit, form and function.



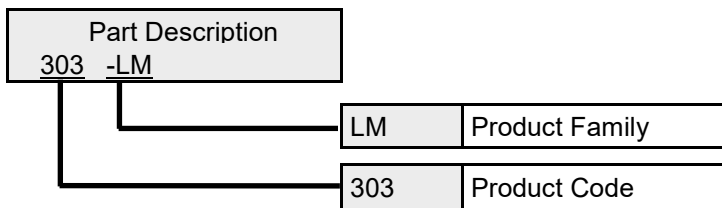

Ordering Description	Labels per sheet	Labels across	Label Width A (mm) (inches)	Label Height B (mm) (inches)	Horizontal Repeat C (mm) (inches)
303-LM	304	8	20.30 0.800	6.40 0.250	25.40 1.000
304-LM	152	8	20.30 0.800	12.70 0.500	25.40 1.000
305-LM	175	7	25.40 1.000	9.50 0.375	27.90 1.100
307-LM	133	7	25.40 1.000	12.70 0.500	27.90 1.100
308-LM	60	5	38.10 1.500	19.10 0.750	40.60 1.600
318-LM	40	4	50.80 2.000	25.40 1.000	N/A N/A
319-LM	10	2	76.20 3.000	50.80 2.000	88.90 3.500
325-LM	1	1	215.9 8.500	279.4 11.000	N/A N/A

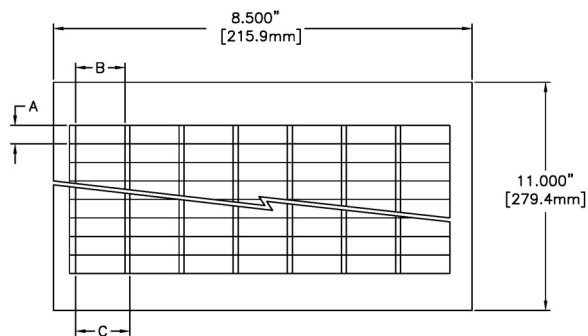

Ordering Information - LM, US sheet format: 8.5 x 11.0 inches (215.9 x 279.4 mm), colour: silver

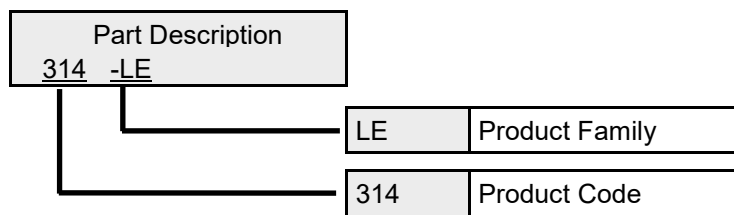

Ordering Description	Labels per sheet	Labels across	Label Width A (mm) (inches)	Label Height B (mm) (inches)	Horizontal Repeat C (mm) (inches)
314-LE	400	16	9.50 0.375	9.50 0.375	12.70 0.500
301-LE	480	10	16.50 0.650	5.10 0.200	20.30 0.800
303-LE	304	8	20.30 0.800	6.30 0.250	25.40 1.000
304-LE	152	8	20.30 0.800	12.70 0.500	25.40 1.000
309-LE	266	7	25.40 1.000	6.30 0.250	27.90 1.100
305-LE	175	7	25.40 1.000	9.50 0.375	27.90 1.100
307-LE	133	7	25.40 1.000	12.70 0.500	27.90 1.100
310-LE	190	5	38.10 1.500	6.30 0.250	40.60 1.600
308-LE	60	5	38.10 1.500	19.10 0.750	40.60 1.600
318-LE	40	4	50.80 2.000	25.40 1.000	N/A N/A
319-LE	10	2	76.20 3.000	50.80 2.000	88.90 3.500
325-LE	1	1	215.90 8.500	279.40 11.000	N/A N/A

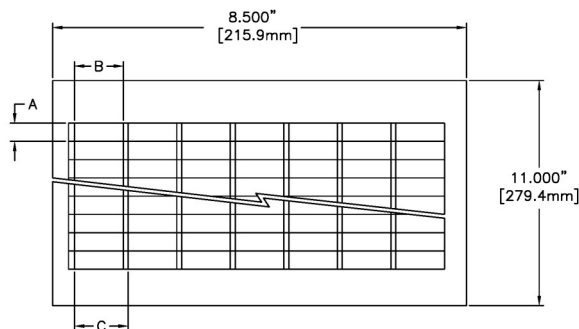

Ordering Information - LE, US sheet format: 8.5 x 11.0 inches (215.9 x 279.4 mm), colour: white

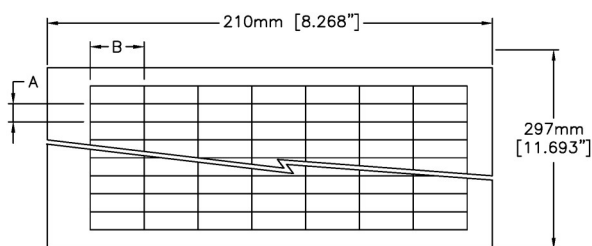
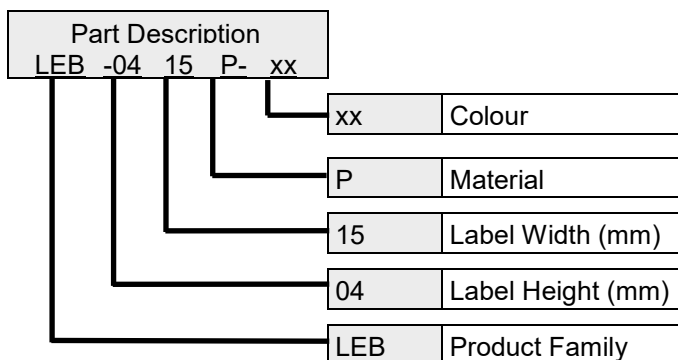

Product Description	Labels per sheet	Labels across	Label Width A (mm) (inches)	Label Height B (mm) (inches)
LEB-0608...	1081	23	8.0 0.315	6.0 0.236
LEB-0415...	792	12	15.24 0.600	4.23 0.167
LEB-0615...	528	12	15.24 0.600	6.35 0.250
LEB-0619...	396	9	19.0 0.748	6.0 0.236
LEB-0636...	220	5	35.56 1.400	6.35 0.250
LEB-0818...	330	10	17.78 0.700	8.47 0.333
LEB-0820...	315	9	20.0 0.787	8.0 0.315
LEB-0825...	231	7	25.4 1.000	8.47 0.333
LEB-0851...	99	3	50.8 2.000	8.47 0.333
LEB-0876...	66	2	76.2 3.000	8.47 0.333
LEB-0884...	66	2	83.82 3.300	8.47 0.333
LEB-0916...	330	11	16.0 0.630	9.0 0.354
LEB-0920...	270	9	20.0 0.787	9.0 0.354
LEB-1318...	220	10	17,78 0.700	12.7 0.500
LEB-1325...	154	7	25.4 1.000	12.7 0.500
LEB-1336...	110	5	35.56 1.400	12.7 0.500
LEB-2156...	39	3	55.88 2.200	21.17 0.833
LEB-2540...	44	4	40.0 1.575	25.0 0.984
LEB-5320...	45	9	20.0 0.787	53.0 2.087

Ordering Information - LEB, A4 sheet format: 210 x 297 mm (8.268 x 11.693 inches)  
Colours: white (P-9), silver (P-8A), yellow (P-4)

## Printer Information

Printers: Monochrome and colour Laser Jet printers were used for technical performance testing.

Monochrome: Samsung SL-M2026W A4 Mono Wireless Laser Printer.

Colour Laser jet printer: HP M452nw LaserJet Pro Colour Printer.



### [www.te.com/rail](http://www.te.com/rail)

TE Connectivity, TE Connectivity (logo) and Every Connection Counts are trademarks. All other logos, products and/or company names referred to herein might be trademarks of their respective owners.

The information given herein, including drawings, illustrations and schematics which are intended for illustration purposes only, is believed to be reliable. However, TE Connectivity makes no warranties as to its accuracy or completeness and disclaims any liability in connection with its use. TE Connectivity's obligations shall only be as set forth in TE Connectivity's Standard Terms and Conditions of Sale for this product and in no case will TE Connectivity be liable for any incidental, indirect or consequential damages arising out of the sale, resale, use or misuse of the product. Users of TE Connectivity products should make their own evaluation to determine the suitability of each such product for the specific application.

© 2019 TE Connectivity Ltd. family of companies All Rights Reserved.