

PRODUCT NO.
78208-XYHLF

- LEAD FREE OPTION
NOTE 6, 7 & 8
- NO. OF POSITIONS
SEE TABLE
- PIN PLATING
- BASE P/N

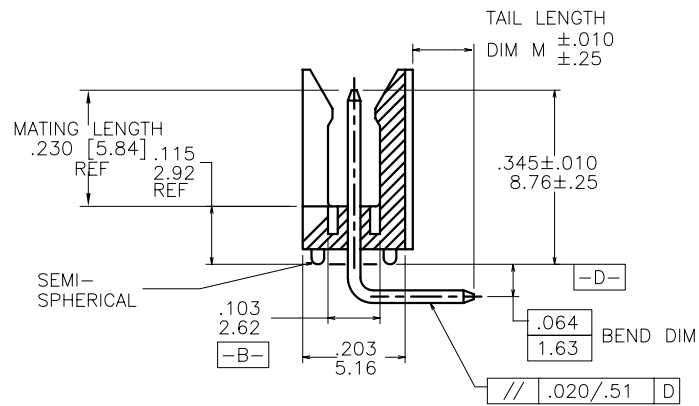
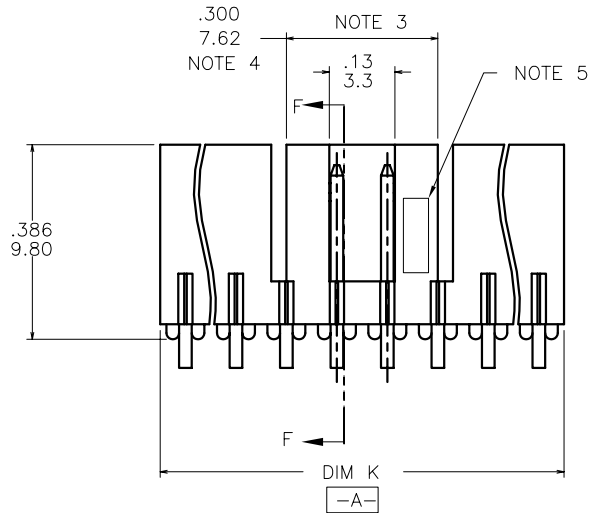
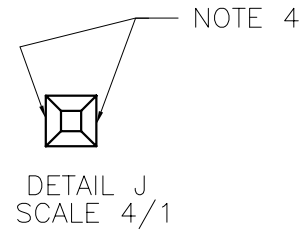
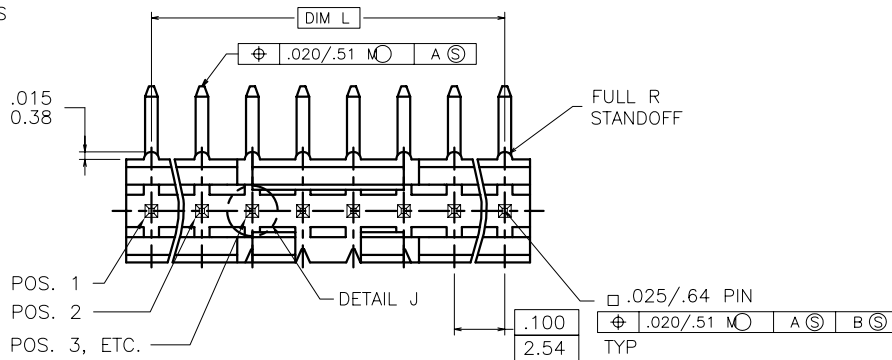

Copyright FCI

mat'l. code				surface ISO 1302	tolerance ISO 406 ISO 1101	projection INCH/MM	product family HEADER
ltr	ecn no	dr	date	tolerances unless otherwise specified		scale 3:1	title FRICTION LATCH HEADER SINGLE ROW, R/A
C	v50318	LSS	5/9/95	angles	linear		dwg no 78208
D	v71183	HTB	9/9/97				sheet 1 of 2 size A3
E	v71470	HTB	10/9/97	0°±2'			type Product Customer Drawing
F	v03-0352	GJP	03/25/03	dr	M.CLOUSER	11/26/90	
G	M05-0134	ERE	06/15/05	engr	C.TREXLER	11/26/90	
H	M06-0256	MHT	9/07/06	chr	C.TREXLER	11/26/90	
J	M08-0023	MHT	1/28/08	appd	C.TREXLER	11/26/90	
sheet	revision	J	J				
index	sheet	1	2				

PRODUCT NO.	NO. OF POS.	DIM K	DIM L	TAIL LENGTH DIM M
78208-X03	1 X 3	.300/7.62	.200/5.08	.120/3.05
-X04	1 X 4	.400/10.16	.300/7.62	
-X05	1 X 5	.500/12.70	.400/10.16	
-X06	1 X 6	.600/15.24	.500/12.70	
-X07	1 X 7	.700/17.78	.600/15.24	
-X08	1 X 8	.800/20.32	.700/17.78	
-X09	1 X 9	.900/22.86	.800/20.32	
-X10	1 X 10	1.000/25.40	.900/22.86	
-X11	1 X 11	1.100/27.94	1.000/25.40	
-X12	1 X 12	1.200/30.48	1.100/27.94	
-X13	1 X 13	1.300/33.02	1.200/30.48	
-X14	1 X 14	1.400/35.56	1.300/33.02	
78208-X15	1 X 15	1.500/38.10	1.400/35.56	.120/3.05
78208-X43	1 X 3	.300/7.62	.200/5.08	.190/4.83

NOTES:
 1. MOLDING MAT'L: GLASS REINFORCED PCT, COLOR: BLACK
 FLAME RETARDANT PER UL-94V-0
 MAXIMUM OPERATING TEMPERATURE 130° C.

2. PIN MATERIAL: 3/4 HD PHOS. BRZ.
 3. NO SLOTS ON 1 X 5 POSITION OR SMALLER PRODUCT. THE CENTER KEY SLOT WILL BE ON ALL HEADERS REGARDLESS OF SIZE.
 4. TWO NON-CRITICAL SIDES OF PIN TIP NOT PLATED, BOTH ENDS.
 5. COMPANY LOGO MAY APPEAR IN THIS AREA.

6. ADD "HLF" SUFFIX AT THE END OF PART NUMBER FOR LEAD FREE OPTION, NOT AVAILABLE FOR -5YY, -5YYH, -6YY & -6YYH.
 7. PART NUMBERS WITH "H" SUFFIX WILL WITHSTAND EXPOSURE TO 260°C PEAK TEMPERATURE FOR 20 SECONDS IN WAVE SOLDER, INFRA-RED OR VAPOR PHASE SOLDER PROCESS.

PART NUMBERS WITHOUT "H" SUFFIX WILL WITHSTAND EXPOSURE TO 260°C PEAK TEMPERATURE FOR WAVE SOLDER PROCESS.

8. THIS PRODUCT MEETS EUROPEAN UNION DIRECTIVES AND OTHER COUNTRY REGULATION AS DESCRIBED IN GS-22-008.

9. PLATING OPTIONS: MAY BE EITHER GOLD OR GXT PLATED AT MANUFACTURER'S OPTION.

10. "THIS PRODUCT HAS 100% TIN PLATING IN THE INTERFACE AND HAS NOT BEEN TESTED FOR WHISKER GROWTH IN ALL INTERCONNECT ENVIRONMENTS."



FCIconnect.com

Copyright FCI

PIN PLATING CODES

-1YY	30u"/.76u (SEE NOTE 9) 50u"/1.27u Ni
-2YY	15u/.38u (SEE NOTE 9) 50u"/1.27u Ni
-3YY	50u"/1.27u Au 50u"/1.27u Ni
-4YY	100u"/2.54u MIN Sn 50u"/1.27u Ni (SEE NOTE 10)
-4YYHLF	
-5YY	15u"/.38u (SEE NOTE 9) 50u"/1.27u Ni
-6YY	30u"/.76u (SEE NOTE 9) 50u"/1.27u Ni
-7YY	30u"/.76u Au OVER 50u"/1.27u Ni
-8YY	15u"/.38u Au OVER 50u"/1.27u Ni

mat'l. code		surface ISO 1302		tolerance ISO 406 ISO 1101		projection 		product family HEADER	
ltr	ecr no	dr	date	tolerances unless otherwise specified		INCH/MM		title	
J				angles	linear	.XX±.01/XX±.03 .XXX±.005/XX±.013 .XXXX±.0020/XXX±.0051		FRICION LATCH HEADER SINGLE ROW, R/A	
				0°±2°		scale 3:1		dwg no 78208	
				dr	M.CLOUSER	11/26/90		sheet 2 of 2 size A3	
				enrg	C.TREXLER	11/26/90		type Product Customer Drawing	
				chr	C.TREXLER	11/26/90			
				appd	C.TREXLER	11/26/90			
sheet	revision								
index	sheet								